



POLARIS[®]
The Way Out.

2006
PREDATOR 50
PREDATOR 90
SPORTSMAN 90

Owner's Manual
for ATV Maintenance
and Safety

WARNING

**Improper vehicle use can result in
SEVERE INJURY or DEATH.**



**ALWAYS USE
AN APPROVED
HELMET AND
PROTECTIVE
GEAR**



**NEVER USE
ON PUBLIC
ROADS**



**NEVER CARRY
PASSENGERS**



**NEVER USE
WITH DRUGS
OR ALCOHOL**

**READ OWNER'S MANUAL.
FOLLOW ALL INSTRUCTIONS
AND WARNINGS.**

Part No. 9920229
PRINTED IN TAIWAN

NEVER:

- Operate without proper training or instruction.
- Operate on public roads. A collision can occur with another vehicle.
- Operate at speeds too fast for your skills or the conditions.
- Use **ALCOHOL** or **DRUGS** before or while operating this vehicle.
- Carry Passengers.

ALWAYS:

- Avoid paved surfaces, which may adversely affect handling and control.
- Use proper **RIDING TECHNIQUES** to avoid vehicle overturns on hills and rough terrain, and in turns.
- Wear eye protection, helmet and protective apparel.



POLARIS®
The Way Out.

 **WARNING**

The engine exhaust from this product contains chemicals known to cause cancer, birth defects or other reproductive harm.

We've created a web site just for YOU!

- Technical tips
- Accessories and apparel
- New product introductions
- Event schedules
- Parts and Service Manual information
- Exciting details about The Way Out

Check it out...

www.polarisindustries.com/owner



POLARIS®
The Way Out.

Copyright 2004 Polaris Sales Inc. All information contained within this publication is based on the latest product information at the time of publication. Due to constant improvements in the design and quality of production components, some minor discrepancies may result between the actual vehicle and the information presented in this publication. Depictions and/or procedures in this publication are intended for reference use only. No liability can be accepted for omissions or inaccuracies. Any reprinting or reuse of the depictions and/or procedures contained within, whether whole or in part, is expressly prohibited. Printed in Taiwan.

2006 Predator 50/Predator 90/Sportsman 90 Owner's Manual P/N 9920229

Welcome

Dear Parents:

We believe your children should have the opportunity to enjoy The Way Out experience along with you. We've provided this owner's manual to assist you and your children in learning about safe operation and care of your new ATV. Please review the information in this manual with any child who may operate the ATV. Help your children learn to operate the ATV with safety as a top priority. Help them also learn to show respect for our environment and for the rights of others while operating the ATV.

Children differ in skills, physical abilities and judgement. Some children may not be able to operate an ATV safely. Always supervise your child's use of the ATV, and permit continued use *only* if you determine that your child has the ability and maturity to operate the ATV safely. Never allow a child to operate the ATV without adult supervision.

The preventive maintenance program outlined in this manual is designed to ensure that all critical components on your child's ATV are thoroughly inspected at various intervals. For safe and enjoyable operation of the vehicle, be sure to follow all of the instructions and recommendations in this manual. If you have any questions about the ATV, contact a Polaris dealer for assistance.

Welcome

Dear Children:

Before you ride your new Polaris ATV, there are some important things that you need to know. Your parents and Polaris want you to enjoy riding your new ATV, and that's why you need to read and understand the information in your owner's manual.

Ask your parents to explain anything you don't understand, and pay close attention to the warnings and instructions you read. Your safety and the safety of others is the most important thing to think about at all times.

As the driver of the ATV, you must learn how to keep yourself and those around you safe while you're riding. So read your manual, and then enjoy riding your new Polaris ATV!

Table of Contents

Welcome	3
Safety	7
Youth Section	17
Know Your ATV	18
Pre-Ride Check	25
Riding Rules	28

Adult Section	33
Safety Decals	34
Driver Warnings	47
Vehicle ID Numbers	70
Features and Controls ..	71
Break-in Period	88
Pre-Ride Inspections ...	90
Starting the Engine	91
Stopping the Engine	93
Driving Safely	94
Hauling Cargo	112
Emission Control	115
Maintenance	116
Specifications	162
Polaris Products	168
Troubleshooting	170
Warranty	176
Index	182

Understand the Warnings

Always follow the age guidelines for your ATV. Never allow a younger child to ride on or drive the ATV. Make sure all operators understand all warnings and the owner's manual before driving the ATV.

Know Your ATV Before Riding

Parents must help their children learn the proper and safe way to ride an ATV. Read the owner's manual with your children before starting the engine for the first time, and review it with them periodically afterwards.

Safety Training

When you purchased this ATV, your Polaris dealer offered a hands-on safety training course that covers all aspects of ATV safety. In addition, you were provided with printed material and a video that instructs operators on safe operating procedures. You should review this information with your child on a regular basis. If you purchased a used Polaris ATV from a party other than a Polaris dealer, you can request this free safety training from any authorized Polaris dealer.

Safety

The following signal words and symbols appear throughout this manual and on your vehicle. Your safety is involved when these words and symbols are used. Become familiar with their meanings before reading the manual.



The *safety alert symbol*, on your vehicle or in this manual, alerts you to the potential for personal injury.



WARNING

The *safety alert warning* indicates a potential hazard that may result in serious injury or death.



CAUTION

The *safety alert caution* indicates a potential hazard that may result in minor personal injury or damage to the vehicle.

CAUTION

A *caution* indicates a situation that may result in damage to the vehicle.

NOTE:

A *note* will alert you to important information or instructions.

WARNING

Failure to follow the warnings in this manual can result in severe injury or death.

A Polaris ATV is not a toy and can be hazardous to operate. This vehicle handles differently than other vehicles such as motorcycles and cars. A collision or rollover can occur quickly, even during routine maneuvers like turning, or driving on hills or over obstacles, if you fail to take proper precautions.

Read and understand the owner's manual and all warnings before operating a Polaris ATV.

Safety

- Read this manual and all labels carefully and follow the operating procedures described.
- Never operate an ATV without proper instruction. **Take a training course.** Riders should receive training from a certified instructor. Contact an authorized Polaris ATV dealer or call Polaris at 1-800-342-3764 to find out about the training courses nearest you.
- Always follow the age guidelines for your machine: 90cc models are designed for children not less than 12 years of age and 50cc models are designed for children not less than 6 years of age. No child under the age of 16 should ride any ATV designed and sold for an adult.
- Do not allow other children to ride this ATV unless they have read the manual, seen the instructional video and taken and passed a Polaris approved riding skill test.
- Always avoid operating an ATV on any paved surfaces, including sidewalks, driveways, parking lots and streets.
- Never operate an ATV on any public street, road or highway, including dirt or gravel roads.
- Always be sure there are no obstacles or people behind your ATV when operating in reverse. Drive slowly and avoid turning at sharp angles in reverse.

Safety

- Never operate an ATV without wearing an approved helmet that fits properly. You should also wear eye protection (goggles or face shield), gloves, boots, long-sleeved shirt or jacket, and long pants.
- Never consume alcohol or drugs before or while operating this ATV.
- Never operate at excessive speeds. Always travel at a speed which is proper for the terrain, visibility and operating conditions, and your experience.
- Never attempt wheelies, jumps or other stunts.
- Always inspect your ATV each time you use it to make sure it is in safe operating condition. Always follow the inspection and maintenance procedures and schedules described in this manual.
- Always keep both hands on the handlebars and both feet on the footrests of the ATV during operation.
- Always go slowly and be extra careful when operating on unfamiliar terrain. Always be alert to changing terrain conditions when operating the ATV.
- Never operate on excessively rough, slippery or loose terrain.

Safety

- Always follow proper procedures for turning as described in this manual. Practice turning at low speeds before attempting to turn at faster speeds. Do not turn at excessive speed.
- Always have the ATV checked by an authorized Polaris dealer if it has been involved in an accident.
- Never operate the ATV on hills too steep for the ATV or for your abilities. Practice on smaller hills before attempting larger hills.
- Always follow proper procedures for climbing hills as described in this manual. Check the terrain carefully before you start up any hill. Never climb hills with excessively slippery or loose surfaces. Shift your weight forward. Never open the throttle suddenly or make sudden gear changes. Never go over the top of any hill at high speed.
- Always follow proper procedures for going down hills and for braking on hills as described in this manual. Check the terrain carefully before you start down any hill. Shift your weight backward. Never go down a hill at high speed. Avoid going down a hill at an angle which would cause the vehicle to lean sharply to one side. Go straight down the hill where possible.

Safety

- Always follow proper procedures for crossing the side of a hill as described in this manual. Avoid hills with excessively slippery or loose surfaces. Shift your weight to the uphill side of the ATV. Never attempt to turn the ATV around on any hill until you have mastered the turning technique described in this manual on level ground. Avoid crossing the side of a steep hill if possible.
- Always use proper procedures if you stall or roll backwards when climbing a hill. To avoid stalling, maintain a steady speed when climbing a hill. If you stall or roll backwards, follow the special procedure for braking described in this manual. Dismount on the uphill side or to either side if pointed straight uphill. Turn the ATV around and remount, following the procedure described in this manual.
- Always be careful of skidding or sliding. On slippery surfaces, such as ice, go slowly and be very cautious in order to reduce the chance of skidding or sliding out of control.

Safety

- Always check for obstacles before operating in a new area. Never attempt to operate over large obstacles, such as rocks or fallen trees. Always follow proper procedures when operating over obstacles as described in this manual.
- Avoid operating the ATV through deep or fast flowing water. If you cannot avoid water which exceeds the recommended maximum depth (pg. 108), go slowly, balance your weight carefully avoiding sudden movements, maintain a slow and steady forward motion, do not make sudden turns or stops, and do not make sudden throttle changes.
- Wet brakes may have reduced stopping ability. Test your brakes after leaving water. If necessary apply them lightly several times to let friction dry out the pads.
- Always use the size and type tires specified in this manual. Always maintain proper tire pressure as described in this manual.
- Never modify an ATV through improper installation or use of accessories.
- Never exceed the stated load capacity for an ATV.
- Always remove the ignition key when the vehicle is not in use to prevent unauthorized use or accidental starting.

FOR MORE INFORMATION ABOUT ATV SAFETY, call the Consumer Product Safety Commission at 1-800-638-2772, or Polaris at 1-800-342-3764.

Equipment Modifications

We are concerned for the safety of our customers and for the general public. Therefore, we strongly recommend that consumers do not install on a Polaris ATV any equipment that may increase the speed or power of the vehicle, or make any other modifications to the vehicle for these purposes. Any modifications to the original equipment of the vehicle create a substantial safety hazard and increase the risk of bodily injury.

The warranty on your Polaris ATV is terminated if any equipment has been added to the vehicle, or if any modifications have been made to the vehicle, that increase its speed or power.

NOTE: The addition of certain accessories may change the handling characteristics of the ATV. Use only Polaris-approved accessories, and familiarize yourself with their function and effect on the ATV.

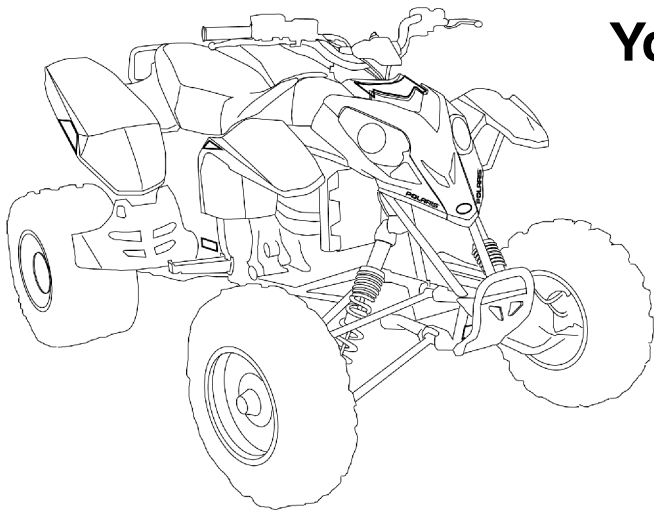

Youth Section

Know Your ATV

PARENTS: Polaris Youth ATVs are equipped with an electronic speed control system to allow adults to limit the speed of the vehicle for the rider's skill and experience. More information on speed limiting functions can be found beginning on page 135.

These units are not designed for adult use. Serious damage to the vehicle may occur if the maximum rider weight capacity is exceeded. See the specifications section beginning on page 162 for your ATV's capacity.

CHILDREN: Before you ride your new Polaris ATV, there are some important things that you need to know. Your safety and the safety of others is the most important thing to think about at all times. As the driver of the ATV, you must learn how to keep yourself and those around you safe while you're riding.

Pay attention when you see this symbol:



This is the safety alert symbol. When you see this symbol on your ATV or in this manual it means **PAY ATTENTION** because you could die or be seriously injured if you don't follow the instructions.

Know Your ATV

Before you have an adult start the engine for you for the first time, let's learn about the controls on your new ATV.

1. **Engine Stop Switch** - When the engine is running, push this button down to shut the engine off quickly. The button must be up before you can start the engine again.
2. **Horn Button (90 cc models)** - Press the horn button to sound the horn.
3. **Throttle Control** - Press the throttle lever with your thumb when you want the ATV to go forward. Always make sure the throttle control does not stick before you drive your ATV. Read more about it on page 25.

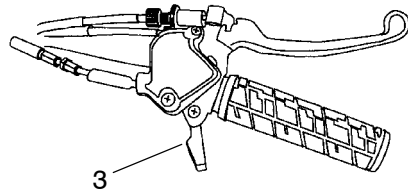
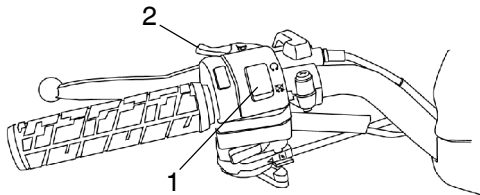

Know Your ATV

4. **Kick-Start Lever** - If your battery is too weak to start your ATV, you can push down on the kick-start lever with your foot to start the engine. Have an adult show you how it works. Read more about how to use the kick-start on page 86.
5. **Shift Lever (90cc models)** - The shift lever is on the right side of your ATV. Read about how to use the shift lever on page 76.

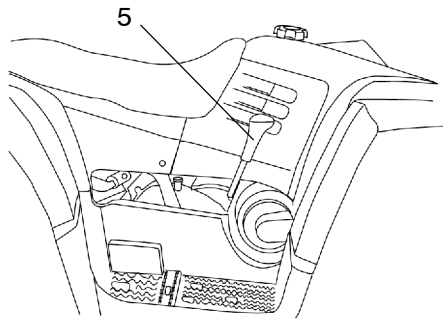
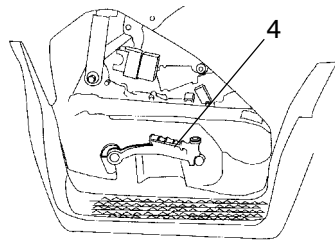

Know Your ATV

- Gas Cap** - The gas cap has to be taken off when an adult puts gas in your ATV. Never take the gas cap off. Always make sure it's tightly closed.



Always have an adult put gas in your ATV. Never try to do it yourself.

- Seat Latch** - To remove the seat, pull up on the seat latch on the lefthand side of the seat. To replace the seat, set it in place and push down on the seat above the latch. Always make sure the seat is locked in place before riding.

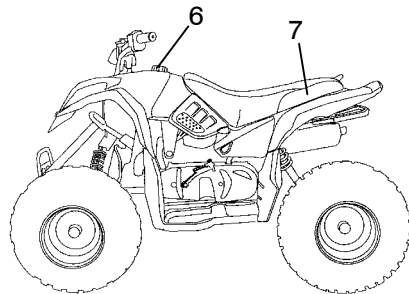

Know Your ATV

- 8. Brake Levers** - Squeeze the brake levers toward the handlebar to slow down or stop the ATV. The lefthand lever (8A) controls the rear brake. The righthand lever (8B) controls the front brake. Always squeeze both brake levers at the same time.



Always squeeze both brake levers at the same time or you could lose control of the ATV and be seriously injured. Always take your thumb off the throttle lever when you squeeze the brake levers.

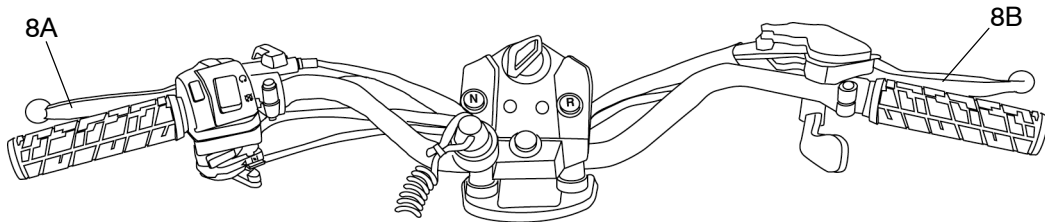

Know Your ATV

- 9. Ignition Switch** - The ignition switch key must be turned on before pushing the starter button. You can also use this key to turn off the engine.
- 10. Tether Strap and Switch** - The tether strap must *always* be attached snugly to your right wrist and to your ATV *every time you drive*. If you fall off your ATV, the tether strap will pull away from the switch and the engine will stop.

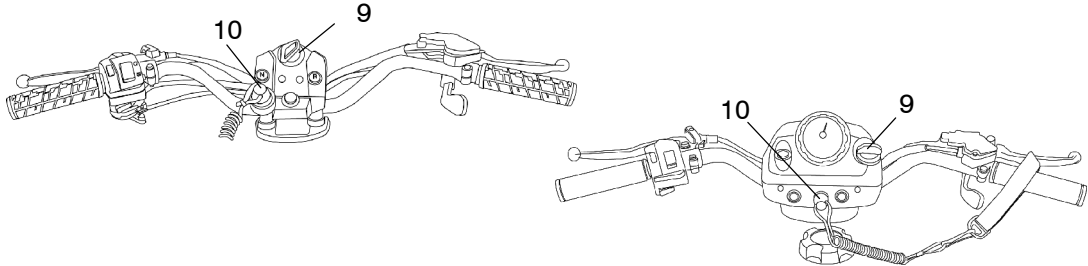

Never ride without the tether strap attached to your right wrist and to your ATV. Be careful not to let the cord get tangled around the handlebars or any part of your body.

Know Your ATV

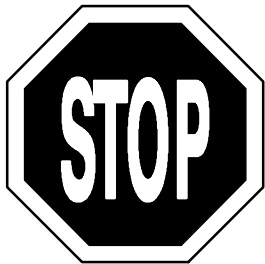

Let's review the three ways to stop your ATV:

1. Push the stop switch down.
2. Pull off the tether strap.
3. Turn the key off.

Pre-Ride Check

We're almost ready to have an adult start your ATV. But before the ATV is started for the first time, you must do a *Pre-Ride Check*. In fact, every time you want to ride you must have an adult help you check some things on your ATV before starting it. Let's learn about these things now.

- ✓ Make sure the throttle doesn't stick. Check this by pushing the throttle lever toward the handlebar and then letting go. The lever should come right back to where it was before you pushed it. If it comes back slowly or stays close to the handlebar, the ATV has a sticky throttle. This means that something is wrong or broken and must be fixed before you can ride your ATV safely.



Never start the engine if you have a sticky throttle. You could be seriously hurt if you ride with a sticky throttle. Have an adult or your Polaris dealer fix the throttle before you ride.

Pre-Ride Check

- ✓ Make sure the brakes don't stick. Check the brake levers by squeezing them toward the handlebar and then letting go. They should come right back to where they were before you squeezed. If they go back slowly or stay close to the handlebar, your ATV has sticky brakes. They must be fixed before you can ride your ATV safely.



Never start the engine if your ATV has sticky brakes. You could be seriously hurt if you ride with sticky brakes. Have an adult or your Polaris dealer fix the sticky brakes before you ride.

- ✓ Have an adult check to see if your ATV needs more gas. *Children must never add their own gasoline.* This must always be done by an adult. Before anyone adds gasoline to your ATV they must read the instructions and warnings on page 83 of this manual.



Always have an adult put gas in your ATV. Never try to do it yourself.

Pre-Ride Check

- ✓ If you used the storage area under the seat, make sure the seat is locked in place.
- ✓ Have an adult check the engine oil level when the engine is cold. The engine is very hot after it has been running and it can burn your skin if you touch it. Children must never check the oil on their own. An adult should always be in charge of keeping the gas and oil levels at the full marks.
- ✓ This last check is done with the engine running. You must check to make sure that *all three ways to stop your ATV* are working the way they should. Do you remember what they are? If you can't remember the three ways to stop your ATV, go back to page 24 and review. Then have an adult help you start your ATV and practice stopping the engine all three ways.

Riding Rules

Now you're ready to learn about riding your Polaris ATV. There are some things you can do and there are some things you must never do. Rules are very important when you're driving an ATV. Adults have riding rules, too. The rules help keep us safe when we ride.

The adult with you is your teacher. Always pay attention to what your teacher says so you can learn how to always drive safely.

Let's learn how to ride!



Always follow the safe riding rules found on the next pages. You or others around you could be seriously hurt if you don't follow the safe riding rules.

Riding Rules

► Always wear the right kind of clothing and safety gear when riding your ATV.

1. **Helmet:** Your helmet is very important for safe riding. A helmet can prevent a severe head injury.

2. **Eye Protection:** Always wear shatterproof goggles or a helmet face shield, and always keep them clean so you can see where you're driving.

3. **Gloves:** Wear gloves to protect your hands from sun and wind. Gloves will also protect your hands from scrapes and scratches.

4. **Boots:** Wear sturdy boots to keep your feet dry. Boots will also protect your feet and ankles from scrapes and scratches.

5. **Clothing:** Make sure your clothing fits properly. If it's too small, it could keep you from moving easily when you shift your weight. If it's too big, it could hang down and get caught in a moving part.

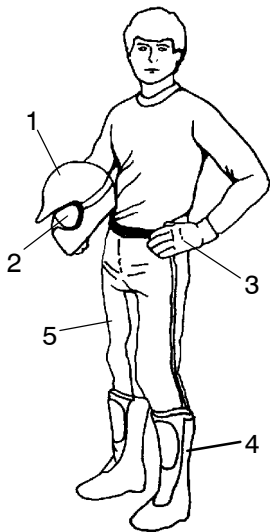

Riding Rules

- ▶ Always attach the tether strap to your right wrist and to the ATV before riding.
- ▶ Make sure you know where you're going to drive before your ATV is started. Make sure the area is safe all around your ATV.
- ▶ Your ATV is made for one person. Never carry a passenger. A passenger will make the ATV harder to drive. You may lose control and hurt yourself and your passenger.
- ▶ Always drive your ATV while sitting down. Keep both hands on the handlebars and keep both feet on the footrests.
- ▶ Always be alert and pay attention to where you're driving. Pay attention to other drivers, and be even more careful around them because you don't know what they're going to do.
- ▶ Never follow another ATV too closely. You need lots of time and space to stop your ATV.

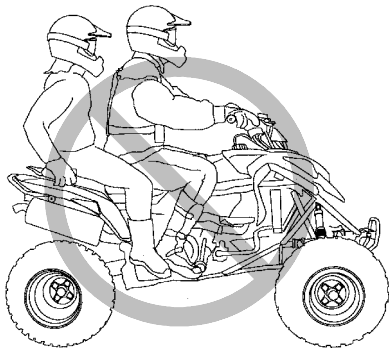

Riding Rules

- ▶ Never ride alone. An adult should always be watching you in case you need help. Always drive within the sight of an adult.
- ▶ Never ride on public trails.
- ▶ Don't ride your ATV on roads or over railroad tracks. Your ATV makes noise that will keep you from hearing cars, trucks or trains that may be coming towards you.
- ▶ Don't ride at night. Your ATV doesn't have lights that are safe for driving in the dark.
- ▶ Learn where there are lakes, rivers, ponds and ditches in your driving area. Stay away from them.
- ▶ Never ride on frozen water. You could get hurt or you could even die. All ice can be dangerous!
- ▶ Ride your ATV only where you know it is safe to drive and where you have permission to drive. Be careful of the things around you.
- ▶ Always be a polite driver. (No driving through the flower garden or over the little trees you planted.)
- ▶ Always do your best to help take care of nature.

*Respect your ATV;
respect your environment;
and you will earn
the respect of everyone.*

Enjoy riding your new Polaris ATV!

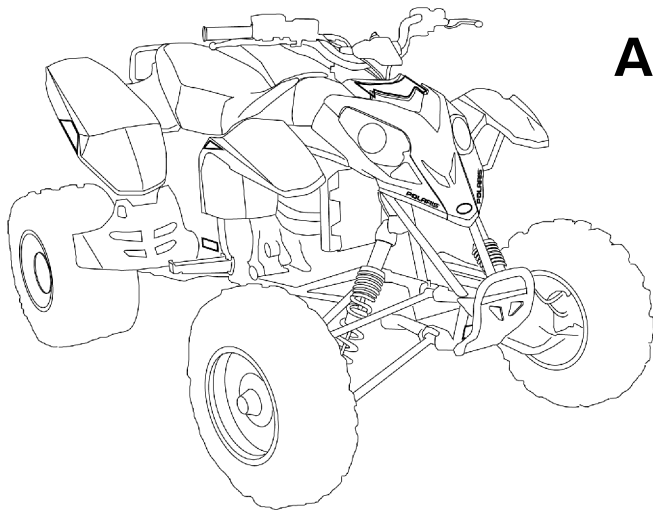

Adult Section

Safety Decals

Warning and safety decals have been placed on the ATV for the protection of the operator. Read and follow the instructions on each decal carefully. If any safety decal becomes illegible or comes off, contact your Polaris dealer for a free replacement. The part number is printed on the decal.

⚠ WARNING

Improper ATV use can result in SEVERE INJURY or DEATH

			
ALWAYS USE AN APPROVED HELMET AND PROTECTIVE GEAR	NEVER USE ON PUBLIC ROADS	NEVER CARRY PASSENGERS	NEVER USE WITH DRUGS OR ALCOHOL

NEVER operate:

- without proper training or instruction
- at speeds too fast for your skills or the conditions
- on public roads - a collision can occur with another vehicle
- with a passenger - passengers affect balance and steering and increase risk of losing control

ALWAYS:

- use proper riding techniques to avoid vehicle overturns on hills and rough terrain and in turns
- avoid paved surfaces - pavement may seriously affect handling and control

LOCATE AND READ OWNER'S MANUAL.
FOLLOW ALL INSTRUCTIONS AND WARNINGS.
IF OWNER'S MANUAL IS MISSING, CONTACT
A POLARIS DEALER FOR A REPLACEMENT.

7172678

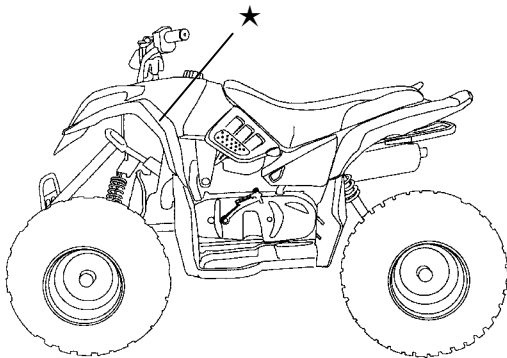

Safety Decals

Improper ATV use can result in SEVERE INJURY OR DEATH.

Always use an approved helmet and protective gear; Never use on public roads

Never carry passengers; Never use with drugs or alcohol

NEVER operate: without proper training or instruction; at speeds too fast for your skills or the conditions; on public roads - a collision can occur with another vehicle; with a passenger - passengers affect balance and steering and increase risk of losing control.

ALWAYS use proper riding techniques to avoid vehicle overturns on hills and rough terrain and in turns; avoid paved surfaces - pavement may seriously affect handling and control

LOCATE AND READ OWNER'S MANUAL. FOLLOW ALL INSTRUCTIONS AND WARNINGS. IF OWNER'S MANUAL IS MISSING, CONTACT A POLARIS DEALER FOR A REPLACEMENT.

Safety Decals

Predator 50 Age Warning Decal

WARNING



- Kids under age 6 should NEVER operate this ATV. Kids under 6 have an increased chance of losing control, which could result in severe injury or death.
- Adult supervision is required.
- Make sure operators follow Owner's Manual and labels.
- Make sure operators watch the safety video and pass the ATV Training Course.
- Never operate this ATV on HILLS steeper than 15 degrees $\angle 15^\circ$. To prevent flipover on hilly terrain, use throttle and brakes gradually.

7172683

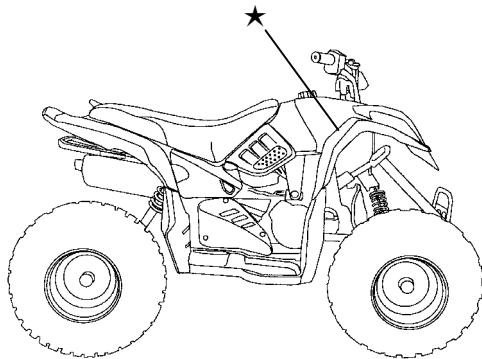

Safety Decals

Predator 50 Age Warning Decal

- Kids under age 6 should NEVER operate this ATV. Kids under 6 have an increased chance of losing control, which could result in severe injury or death.
- Adult supervision is required.
- Make sure operators follow Owner's Manual and labels.
- Make sure operators watch the safety video and pass the ATV Training Course.
- Never operate this ATV on HILLS steeper than 15 degrees \angle 15°. To prevent flipover on hilly terrain, use throttle and brakes gradually.

Safety Decals

Predator 90/Sportsman 90 Age Warning Decal

⚠ WARNING



- Kids under age 12 should NEVER operate this ATV. Kids under 12 have an increased chance of losing control, which could result in severe injury or death.
- Adult supervision is required.
- Make sure operators follow Owner's Manual and labels.
- Make sure operators watch the safety video and pass the ATV Training Course.
- Never operate this ATV on HILLS steeper than 15 degrees $\angle 15^\circ$. To prevent flipover on hilly terrain, use throttle and brakes gradually.
- REVERSE operation can be dangerous even at low speeds. Steering becomes difficult. To prevent flipover, avoid sudden braking or sharp turns.

7173040

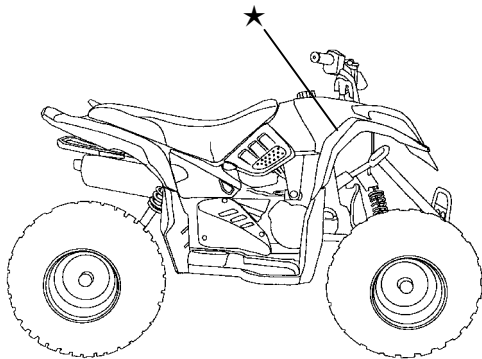

Safety Decals

Predator 90/Sportsman 90 Age Warning Decal

- Kids under age 12 should NEVER operate this ATV. Kids under 12 have an increased chance of losing control, which could result in severe injury or death.
- Adult supervision is required.
- Make sure operators follow Owner's Manual and labels.
- Make sure operators watch the safety video and pass the ATV Training Course.
- Never operate this ATV on HILLS steeper than 15 degrees \angle 15°. To prevent flipover on hilly terrain, use throttle and brakes gradually.
- REVERSE operation can be dangerous even at low speeds. Steering becomes difficult. To prevent flipover, avoid sudden braking or sharp turns.

Safety Decals

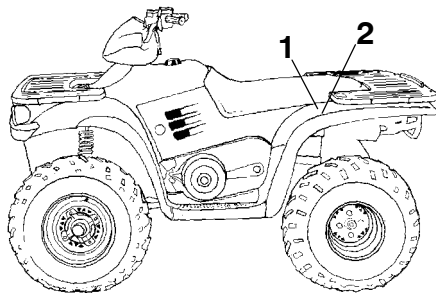
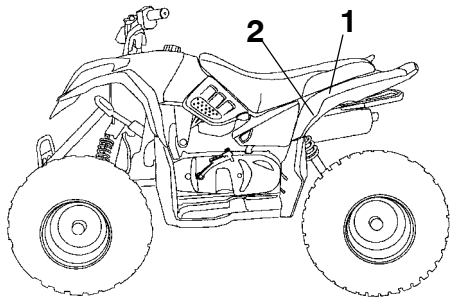

1



Safety Decals

2 (Predator 50)

WARNING

IMPROPER TIRE PRESSURE OR OVERLOADING can cause loss of control, resulting in SEVERE INJURY OR DEATH.

**TIRE PRESSURE (PSI): FRONT 2 REAR 2
MAXIMUM WEIGHT CAPACITY
(Gross Vehicle Weight) INCLUDING MACHINE,
DRIVER AND CARGO IS 311 LBS.** 7172684

2 (Predator 90)

WARNING

IMPROPER TIRE PRESSURE OR OVERLOADING can cause loss of control, resulting in SEVERE INJURY OR DEATH.

**TIRE PRESSURE (PSI): FRONT 3 (20.7) REAR 3 (20.7)
MAXIMUM WEIGHT CAPACITY
(Gross Vehicle Weight) INCLUDING MACHINE,
DRIVER AND CARGO IS 437 LBS. (198 KG)** 7172682

2 (Sportsman 90)

WARNING

IMPROPER TIRE PRESSURE OR OVERLOADING can cause loss of control resulting in SEVERE INJURY OR DEATH.

TIRE PRESSURE (PSI): FRONT 3 (20.7) REAR 3 (20.7)

MAXIMUM WEIGHT CAPACITY (Gross Vehicle Weight INCLUDING MACHINE, DRIVER AND CARGO IS 481 LBS./218 KG)

Reduce speed and allow greater distance for braking when carrying cargo. Overloading or carrying tall, off-center, or unsecured loads will increase your risk of losing control. Loads should be centered, carried as low as possible, and firmly secured to the racks. With dual racks, load distribution 1/3 front 2/3 rear is best. For stability on rough or hilly terrain, reduce speed and cargo. Be careful if load extends over the side of the rack.

Read Owner's Manual for more detailed loading information.

7172681

Safety Decals

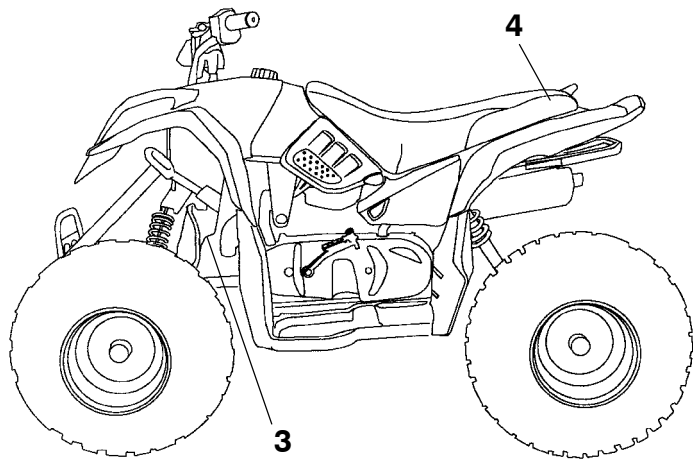

Safety Decals

3

ATTENTION

- Operation of this vehicle without the filter element will severely damage the engine.
- Clean air filter often, more frequent cleaning required in dusty conditions.
- Specific carburetor jetting and adjustments are required depending on temperature and altitude. See your Owner's Manual.

Factory Setting:

40° to 80° F. at 0-3000 feet.
(5° to 27° C. at 0-900 meters)

(on air filter box)

4



(on rear of seat)

**NO PASSENGER
PASSAGERS INTERDITS**

Safety Decals

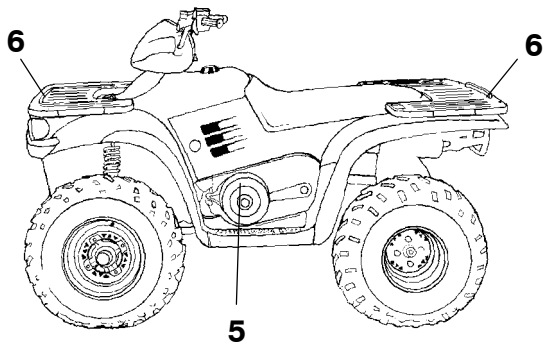
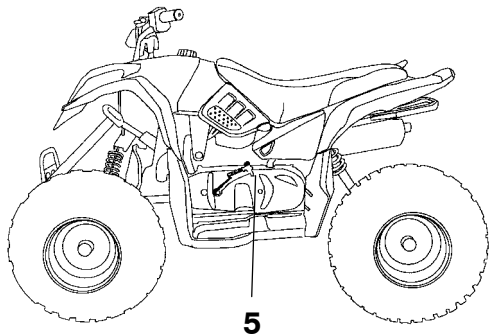

Safety Decals

5

NO STEP

⚠️ WARNING

Moving parts hazard under belt-clutch guard. To prevent serious injury, do not operate vehicle with guard removed.

Do not modify engine or clutch. Doing so can cause part failure, possible imbalance, and excessive engine RPM which can result in serious injury or death.

7172679

⚠️ WARNING

DO NOT TOW FROM RACK OR BUMPER. Vehicle damage or tipover may result causing severe injury or death. Tow only from tow hooks or hitch.

Maximum Rack Loads: Front 10 lbs.; Rear 20 lbs.

7172680

6 (Sportsman 90)



MANUFACTURED
IN TAIWAN

DATE:

VIN:

THIS VEHICLE IS AN ALL TERRAIN VEHICLE AND IS
NOT INTENDED FOR USE ON PUBLIC ROADS.

CE VÉHICULE EST UN VÉHICULE TOUT TERRAIN
QUI N'EST PAS DESTINÉ À ÊTRE UTILISÉ SUR
LES CHEMINS PUBLICS.

Driver Warnings

Be sure to read all of the following warnings about driving hazards and how to avoid them. These warnings are provided for your child's safety, so be sure to explain to your young driver that the following hazards MUST be avoided at all times.

Driver Warnings

WARNING

POTENTIAL HAZARD

Operating this ATV without proper instruction.

WHAT CAN HAPPEN

The risk of an accident is greatly increased if the operator does not know how to operate the ATV properly in different situations and on different types of terrain.

HOW TO AVOID THE HAZARD

Beginning and inexperienced operators should complete the certified training course offered by Polaris Industries Inc. They should then regularly practice the skills learned in the course and the operating techniques described in the Owner's Manual.

For more information about the training course, contact an authorized ATV dealer or call Polaris at 1-800-342-3764.

WARNING

POTENTIAL HAZARD

Failure to follow the age recommendations for this ATV.

WHAT CAN HAPPEN

Use by children of ATVs that are not recommended for their age can lead to severe injury or death of the child.

Even though a child may be within the age group for which some ATVs are recommended, he or she may not have the skills, abilities, or judgment needed to operate the ATV safely and may be involved in a serious accident.

HOW TO AVOID THE HAZARD

Follow the age guidelines printed on your machine.

Driver Warnings

⚠ WARNING

POTENTIAL HAZARD

Carrying a passenger on this ATV.

WHAT CAN HAPPEN

Greatly reduces your ability to balance and control this ATV.

Could cause an accident, resulting in harm to you and/or your passenger.

HOW TO AVOID THE HAZARD

Never carry a passenger. The long seat is to allow the operator to shift position as needed during operation. It is not for passengers.

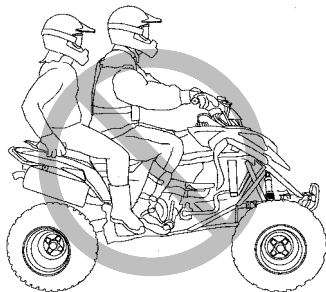

Driver Warnings

⚠ WARNING

POTENTIAL HAZARD

Operating this ATV on paved surfaces, including sidewalks, paths, parking lots and driveways.

WHAT CAN HAPPEN

The ATV tires are designed for off-road use. Paved surfaces may seriously affect handling and control of the ATV, and may cause the vehicle to go out of control.

HOW TO AVOID THE HAZARD

Avoid operating the ATV on pavement whenever possible. If you must ride on a paved surface, go slowly and do not make sudden turns or stops.

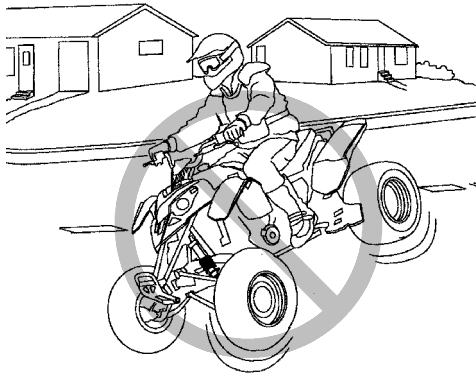

Driver Warnings

⚠️ WARNING

POTENTIAL HAZARD

Operating this ATV on public streets, roads or highways.

WHAT CAN HAPPEN

You can collide with another vehicle.

HOW TO AVOID THE HAZARD

Never operate this ATV on any public street, road or highway, even a dirt or gravel one.

In many states it is illegal to operate ATVs on public streets, roads and highways.

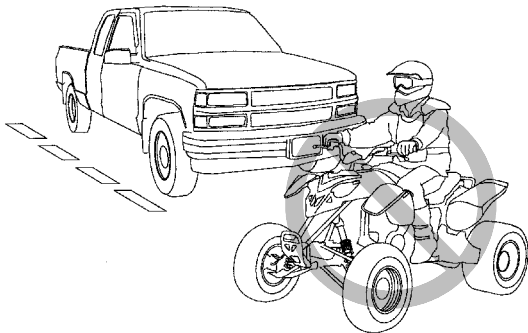

WARNING

POTENTIAL HAZARD

Operating this ATV without wearing an approved helmet, eye protection and protective clothing.

WHAT CAN HAPPEN

Operating without an approved helmet increases your chances of a severe head injury or death in the event of an accident.

Operating without eye protection can result in an accident and increases your chances of a severe injury in the event of an accident.

HOW TO AVOID THE HAZARD

Always wear an approved helmet which fits properly. You should also wear: eye protection (goggles or face shield); gloves; boots; long-sleeved shirt or jacket; and long pants.

Driver Warnings

⚠ WARNING

POTENTIAL HAZARD

Operating this ATV after consuming alcohol or drugs.

WHAT CAN HAPPEN

Could seriously affect your judgment.

Could cause you to react more slowly.

Could affect your balance and perception.

Could result in an accident.

HOW TO AVOID THE HAZARD

Never consume alcohol or drugs before or while driving this ATV.



Driver Warnings



WARNING

POTENTIAL HAZARD

Operating this ATV at excessive speeds.

WHAT CAN HAPPEN

Increases your chances of losing control of the ATV, which can result in an accident.

HOW TO AVOID THE HAZARD

Always travel at a speed which is proper for the terrain, visibility and operating conditions; and your experience.



WARNING

POTENTIAL HAZARD

Failure to inspect the ATV before operating.

Failure to properly maintain the ATV.

WHAT CAN HAPPEN

Increases the possibility of an accident or equipment damage.

HOW TO AVOID THE HAZARD

Always inspect your ATV each time you use it to make sure the ATV is in safe operating condition.

Always follow the inspection and maintenance procedures and schedules described in the Owner's Manual.

Driver Warnings

⚠️ WARNING

POTENTIAL HAZARD

Attempting wheelies, jumps and other stunts.

WHAT CAN HAPPEN

Attempting stunts increases the chance of an accident, including an overturn.

HOW TO AVOID THE HAZARD

Never attempt wheelies, jumps, or other stunts. Avoid exhibition driving (don't show off).

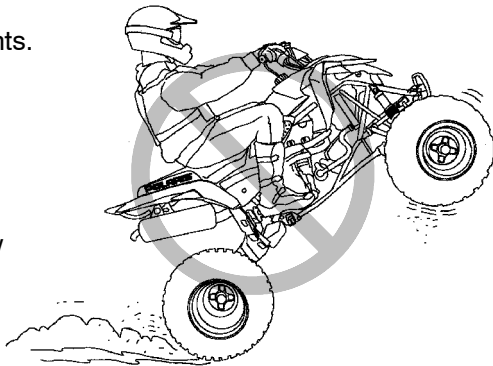



WARNING

POTENTIAL HAZARD

Removing hands from handlebars or feet from footrests during operation.

WHAT CAN HAPPEN

Removing even one hand or foot can reduce your ability to control the ATV or could cause you to lose your balance and fall off the ATV. If you remove a foot from the footrest, your foot or leg may come into contact with the rear wheels, which could injure you or cause an accident.

HOW TO AVOID THE HAZARD

Always keep both hands on the handlebars and both feet on the footrests of your ATV during operation.

Driver Warnings

⚠ WARNING

POTENTIAL HAZARD

Failure to use extra care when operating this ATV on unfamiliar terrain.

WHAT CAN HAPPEN

You can come upon hidden rocks, bumps, or holes, without enough time to react.

Could result in the ATV overturning or going out of control.

HOW TO AVOID THE HAZARD

Go slowly and be extra careful when operating on unfamiliar terrain.

Always be alert to changing terrain conditions when operating the ATV.

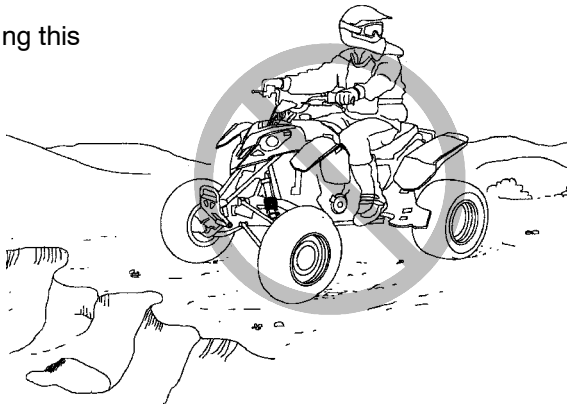

WARNING

POTENTIAL HAZARD

Failure to use extra caution when operating on excessively rough, slippery or loose terrain.

WHAT CAN HAPPEN

Operating on excessively rough, slippery or loose terrain could cause loss of traction or loss of control, which could result in an accident or overturn.

HOW TO AVOID THE HAZARD

Do not operate on excessively rough, slippery or loose terrain until you've learned and practiced the skills necessary to control the ATV on such terrain.

Always use extra caution on rough, slippery or loose terrain.

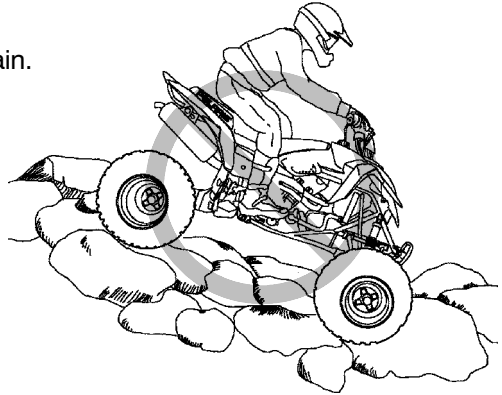

Driver Warnings

WARNING

POTENTIAL HAZARD

Turning improperly.

WHAT CAN HAPPEN

Improper turns could cause loss of control and lead to a collision or overturn.

HOW TO AVOID THE HAZARD

Always follow proper procedures for turning as described in the owner's manual.

Practice turning at slow speeds before attempting to turn at faster speeds.

Never turn at excessive speed.

⚠ WARNING

POTENTIAL HAZARD

Climbing hills improperly.

WHAT CAN HAPPEN

Improper hill climbing could cause loss of control or overturn.

HOW TO AVOID THE HAZARD

Always follow proper procedures for climbing hills as described in the Owner's Manual beginning on page 100.

Always check the terrain carefully before you start up any hill. Never climb hills with excessively slippery or loose surfaces. Shift your weight forward.

Never open the throttle suddenly. The ATV could flip over backwards. Never go over the top of any hill at high speed. An obstacle, a sharp drop, or another vehicle or person could be on the other side of the hill.

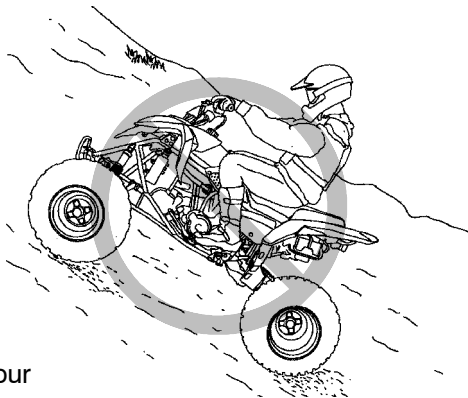

Driver Warnings

⚠ WARNING

POTENTIAL HAZARD

Going down a hill improperly.

WHAT CAN HAPPEN

Driving downhill improperly could cause loss of control or ATV overturn.

HOW TO AVOID THE HAZARD

Always follow proper procedures for going down hills as described in the Owner's Manual. See page 106.

NOTE: A special technique is required when braking as you go downhill.

Always check the terrain carefully before you start down any hill. Shift your weight backward. Never go down a hill at high speed.

Avoid going down a hill at an angle, which would cause the vehicle to lean sharply to one side. Go straight down the hill when possible.

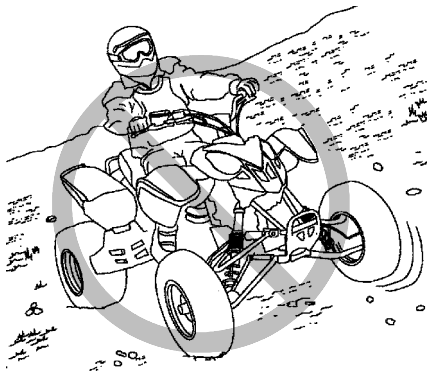

⚠ WARNING

POTENTIAL HAZARD

Improperly crossing hills and turning on hills.

WHAT CAN HAPPEN

Improperly crossing or turning as hills could cause loss of control or overturn.

HOW TO AVOID THE HAZARD

Never try to turn the ATV around on any hill until you've mastered the turning technique (on level ground) as described in the owner's manual. See page 104. Use extra caution when turning on any hill. Avoid crossing the side of a steep hill.

When crossing the side of a hill:

Always follow proper procedures as described in the owner's manual. Avoid hills with excessively slippery or loose surfaces. Shift your weight to the uphill side of the ATV.



Driver Warnings

⚠ WARNING

POTENTIAL HAZARD

Stalling, rolling backwards or improperly dismounting while climbing a hill.

WHAT CAN HAPPEN

The ATV could overturn.

HOW TO AVOID THE HAZARD

Maintain steady speed when climbing a hill.

If you lose all forward speed: Keep your weight uphill. Apply the front brakes gradually (right lever). When fully stopped, apply the rear brake as well (left lever) and then lock the parking brake.

If you begin rolling backwards: Keep weight uphill. Never apply engine power. Never apply the rear brake while rolling backwards. Apply the front brake slowly. When fully stopped, apply rear brake as well, and then lock the parking brake. Dismount on uphill side, or to either side if pointed straight uphill. Turn the ATV around and remount, following the procedure described in the Owner's Manual. See page 104.

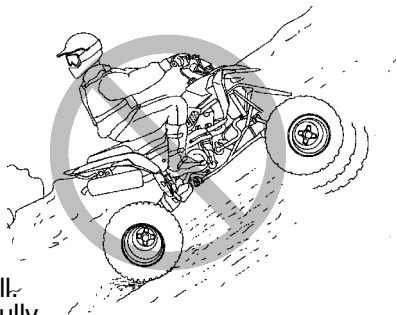

Driver Warnings



WARNING

POTENTIAL HAZARD

Skidding or sliding.

WHAT CAN HAPPEN

Skidding or sliding can cause loss of control.

If the tires regain traction unexpectedly, the ATV could overturn.

HOW TO AVOID THE HAZARD

On slippery surfaces such as ice, travel slowly and use extra caution to reduce the chance of skidding or sliding out of control.



WARNING

POTENTIAL HAZARD

Improperly operating over obstacles.

WHAT CAN HAPPEN

Operating over obstacles could cause loss of control or overturn.

HOW TO AVOID THE HAZARD

Before operating in a new area, check for obstacles.

Avoid operating over large obstacles such as rocks and fallen trees when possible. If unavoidable, use extreme caution and always follow proper procedures as outlined in the owner's manual.

Driver Warnings

WARNING

POTENTIAL HAZARD

Riding on frozen lakes and rivers.

WHAT CAN HAPPEN

Severe injury or death can result if the ATV and/or the operator break through the ice.

HOW TO AVOID THE HAZARD

Never ride your ATV on a frozen body of water.

WARNING

POTENTIAL HAZARD

Operating this ATV with improper tires, or with improper or uneven tire pressure.

WHAT CAN HAPPEN

Use of improper tires, or operation of the ATV with improper or uneven tire pressure, could cause loss of control or accident.

HOW TO AVOID THE HAZARD

Always use the size and type of tires specified in the owner's manual for the ATV.

Always maintain proper tire pressure as stated in the specifications section of the owner's manual.

WARNING

POTENTIAL HAZARD

Operating the ATV through deep or fast-flowing water.

WHAT CAN HAPPEN

Tires may float, causing loss of traction and loss of control, which could lead to an accident or overturn.

HOW TO AVOID THE HAZARD

Avoid operating the ATV through deep or fast-flowing water. If it's unavoidable to enter water that exceeds the recommended maximum depth (see page 108), travel slowly, balance your weight carefully, avoid sudden movements, and maintain a slow and steady forward motion. Do not make sudden turns or stops, and do not make sudden throttle changes.

Wet brakes may have reduced stopping ability. Always test the brakes after leaving water. If necessary, apply them several times to let friction dry out the pads.

Driver Warnings

WARNING

POTENTIAL HAZARD

Overloading the ATV.

WHAT CAN HAPPEN

Overloading the ATV could cause changes in handling, which could lead to an accident.

HOW TO AVOID THE HAZARD

Never exceed the stated load capacity for this ATV.

If equipped with racks, cargo should be properly distributed and securely attached.

WARNING

POTENTIAL HAZARD

Operating the ATV with improper modifications.

WHAT CAN HAPPEN

Improper installation of accessories or modification of the ATV may cause changes in handling which could lead to an accident.

HOW TO AVOID THE HAZARD

Never modify the ATV through improper installation or use of accessories. All parts and accessories added to the vehicle must be genuine Polaris Industries Inc. or equivalent components designed for use on this ATV and should be installed and used according to approved instructions.

Driver Warnings

WARNING

Safe operation of this rider active vehicle requires good judgement and physical skills. Persons with cognitive or physical disabilities who operate this vehicle have an increased risk of overturns and loss of control which could result in severe injury or death.

WARNING

Leaving the keys in the ignition can lead to unauthorized use of the vehicle resulting in serious injury or death. Always remove the ignition key when the vehicle is not in use.

WARNING

After a rollover or an accident, have a qualified service dealer check the complete machine including, but not limited to, brakes, throttle and steering for possible damage.

Vehicle Identification Numbers

Record your ATV's identification numbers and key number in the spaces provided. Remove the spare key and store it in a safe place. Your key can be duplicated only by mating a Polaris key blank with one of your existing keys, so if both keys are lost, the ignition switch must be replaced.

The Predator 50 VIN is located on the righthand lower frame tube. The Predator 90 and Sportsman 90 VIN is located on the righthand front upper shock mount.

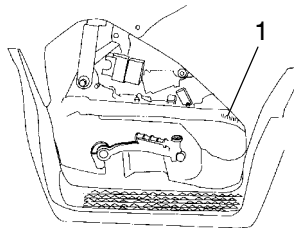

Vehicle Model Number: _____

Frame VIN: _____

Engine Serial Number (1): _____

Key Number: _____

Features and Controls

Main Switch (A)

The main switch is located on the pod. This switch is operated with a key and must be turned clockwise to the ON position before starting the engine.

WARNING

Leaving the keys in the ignition can lead to unauthorized use of the vehicle resulting in serious injury or death. Always remove the ignition key when the vehicle is not in use.

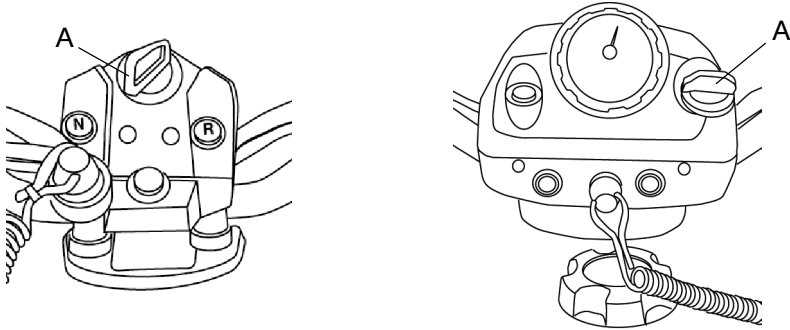

Features and Controls

Engine Stop Switch (B)

The stop switch (B) is located on the top of the left handlebar. The engine will not start or run when the stop switch is down, in the OFF position. Its purpose is to provide the operator with a quick means of engine shutdown in case of stuck throttle or other emergency. **NOTE:** Both the main switch and the emergency engine stop switch shut off all electrical power to the entire vehicle. To stop the engine quickly, push the stop switch down.

Choke Lever (C)

The choke lever (C) is located on the bottom of the left handlebar. The choke is used when starting a cold engine. Push the choke lever to the left before starting the engine. When the engine starts, gradually return the choke lever to the OFF position as the engine warms up and runs smoothly.

Horn Button (D)

The horn button is located on the lefthand control (Sportsman 90 and Predator 90).

Features and Controls

Engine Start Button (E)

The start button is located slightly above the choke lever. To start the engine, make sure the tether strap is securely plugged into the machine and attached to the rider's right wrist. If you have a 90cc model, make sure the shift lever is in neutral. The neutral light will come on when the lever is in neutral. See page 81.

1. Turn the key to the ON position.
2. Set the parking brake.
3. Push the start button up to the ON position.
4. Press the start button.

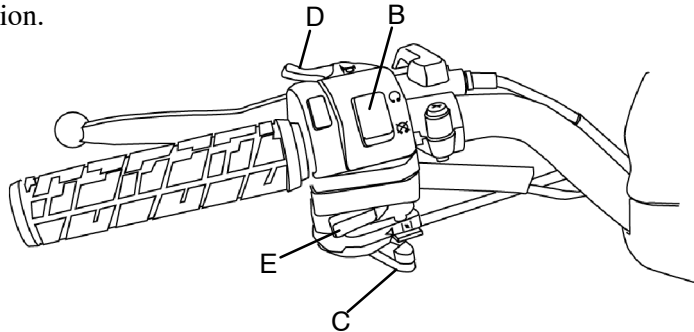

Features and Controls

Throttle Controls

WARNING

Operating an ATV with sticking or improperly operating throttle controls could cause an accident and lead to severe injury or death.

Never start or operate an ATV with a sticking or improperly operating throttle. Always contact your dealer for service if throttle problems arise.

Failure to check or maintain proper operation of the throttle system can result in an accident if the throttle lever sticks during operation. Always check the lever for free movement and return before starting the engine. Also check occasionally during operation.

Features and Controls

Throttle Lever

Engine speed and vehicle movement are controlled by pressing the throttle lever (A). The throttle lever is spring loaded. Engine speed returns to idle when the lever is released.

This ATV is equipped with an Electronic Throttle Control (ETC), which is designed to reduce the risk of a frozen or stuck throttle. If the throttle cable should stick in an open position when the operator releases the throttle lever, the engine will stop and power to the rear wheels will cease.

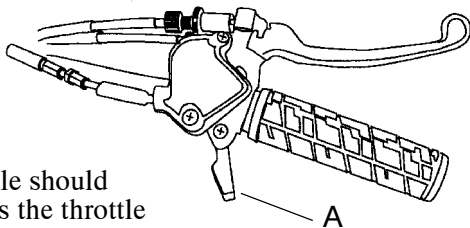

! WARNING

The Electronic Throttle Control (ETC) stops the engine in the event of a throttle system malfunction and is provided for your safety. Do not attempt to modify the ETC system or replace it with any after market throttle mechanism.

Features and Controls

Shift Lever (90cc models)

To change gears, stop the ATV. With the engine idling, move the lever (1) to the desired gear. Do not try to shift gears with engine speed above idle or while the ATV is moving.

Maintaining shift linkage adjustment is important to assure proper transmission function. See your dealer if you experience any shifting problems.

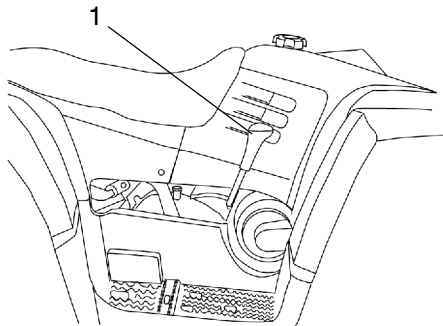

Shift Pattern

F: Forward Gear

N: Neutral

R: Reverse



CAUTION

Do not attempt to shift the transmission while the vehicle is moving or damage to the transmission could result. Always shift when the vehicle is stationary and the engine is at idle.

Always place the transmission in gear with the parking brake applied and turn the vehicle off whenever the vehicle is left unattended.

Features and Controls

Brakes

To activate the rear brake, squeeze the lefthand lever (A) toward the handlebar. The front brakes are activated by squeezing the lever (B) on the righthand handlebar.

WARNING

Applying only one brake could cause loss of control and result in serious injury or death. Always apply both brakes at the same time.

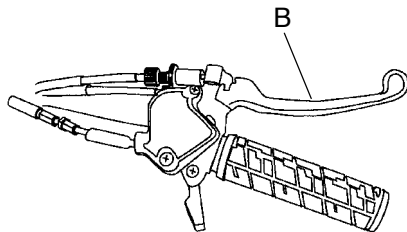
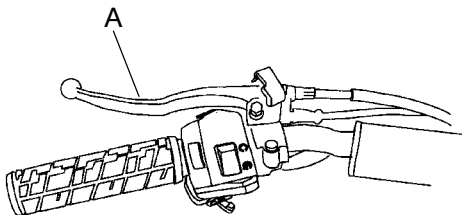

Features and Controls

Brakes

Setting the Parking Brake

1. Squeeze the lefthand brake lever (A).
2. Push the park brake lock (B) down. This will prevent the lever from returning to the released position.
3. To release the parking brake lock, squeeze and release the brake lever. The parking brake will release automatically.

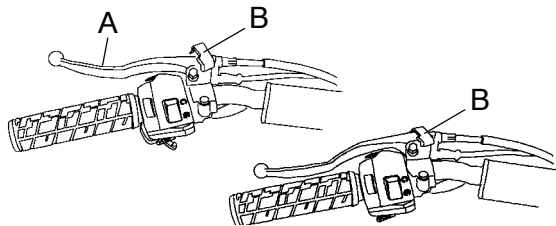

! WARNING

Operating the ATV while the parking brake is engaged could cause an accident resulting in serious injury or death. It could also result in driveline or engine damage. Always be sure to disengage the parking brake before operating the ATV.

Features and Controls

Brakes

Parking Brake

NOTE: The Predator 50 has a PVT system that's always in forward. Always lock the park brake before starting the engine. Since the transmission is always in forward gear, activating the throttle to warm the engine will make the machine move forward if the park brake is not locked.

On 90cc models, always shift the transmission to neutral and lock the park brake before starting the engine.

After the engine has warmed enough for operation, shift to the desired gear (90cc models).

Release the park brake and gently apply the throttle.

Always lock the parking brake whenever the vehicle is left unattended.

Features and Controls

Lights

⚠ WARNING

Polaris Youth ATVs are not equipped with lights that are designed for driving in the dark. Do not operate this ATV after dark. Use caution and drive at reduced speeds in conditions of reduced visibility. This ATV is designed for off-road use only. Do not operate this ATV on streets or highways.

Indicator Lights

Indicator lights on the ATV let you know when your ATV is in neutral or reverse (90cc models). The low oil light comes on if the engine oil level gets too low. If this happens, turn the engine off and have an adult check your ATV.

- N: Neutral (Green)
- R: Reverse (Amber)
- O: Low Oil (Red)

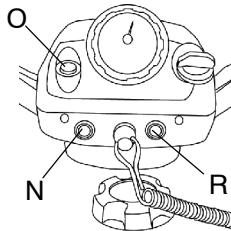
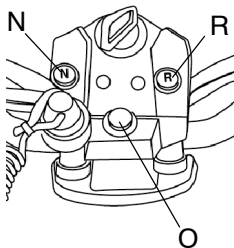

Features and Controls

Oil System

CAUTION

Mixing brands or using a non-recommended oil may cause serious engine damage. We recommend the use of Polaris VES II Synthetic 2-cycle oil or Polaris Premium Gold Synthetic 2-cycle oil. Never substitute or mix oil brands.

To avoid serious engine damage, always top off the oil level when refueling.

The oil tank (A) is located under the seat and has a capacity of 1.1 quarts (1 liter). Always top off the oil level when refueling.

NOTE: See page 21 for seat removal instructions.

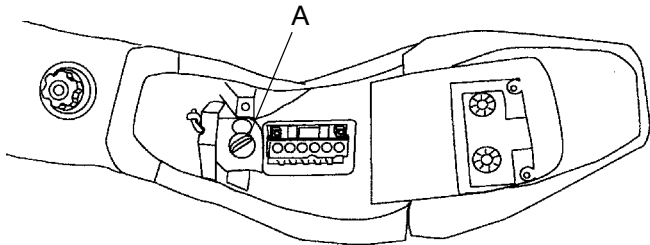

Fuel System

WARNING

Gasoline is highly flammable and explosive under certain conditions.

- Always exercise extreme caution whenever handling gasoline.
- Always refuel with the engine stopped, and outdoors or in a well ventilated area.
- Do not smoke or allow open flames or sparks in or near the area where refueling is performed or where gasoline is stored.
- Do not overfill the tank. Do not fill the tank neck.
- If gasoline spills on your skin or clothing, immediately wash it off with soap and water and change clothing.
- Never start the engine or let it run in an enclosed area. Engine exhaust fumes are poisonous and can cause loss of consciousness or death in a short time.
- Turn the fuel valve off whenever the ATV is stored or parked.

Features and Controls

Fuel System

WARNING

The engine exhaust from this product contains chemicals known to cause cancer, birth defects or other reproductive harm.

Operate this vehicle only outdoors or in well-ventilated areas.

Gas Cap

The fuel tank filler cap (A) is located directly below the handlebars. The tank has a capacity of 1.3 gallons (5 liters). Use unleaded gasoline with a minimum pump octane of 87.

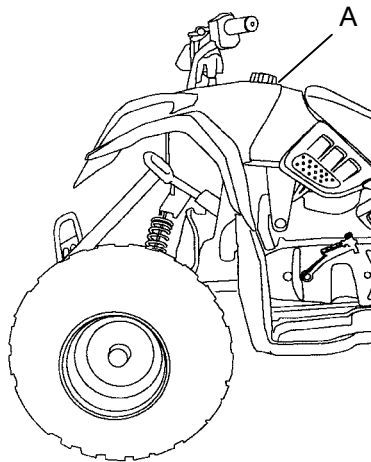

Features and Controls

Fuel System

Fuel Valve

The fuel valve is located on the lefthand side of the ATV. It has three positions:

OFF: For vehicle storage and when transporting.

ON: For normal operation.

RES: For reserve supply if main supply is exhausted.

NOTE: There's about a 7-10 mile (11-16 km) range on reserve gas. Always refill the gas tank as soon as possible after using the main supply. Always return the valve to the ON position after refueling.

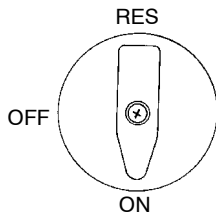

Sportsman

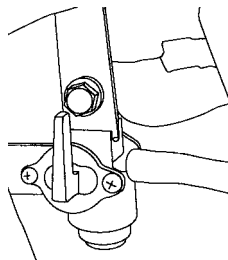

Predator

Fuel Filter

The Polaris ATV is equipped with an in-line fuel filter. This filter should be replaced by your dealer after every 100 hours of operation or annually. Do not attempt to clean the fuel filter.

Features and Controls

Kick-Start Lever

If the battery becomes too weak to start the engine, the kick-start lever will allow you to start the engine until the battery is serviced. Be sure the ATV is on a level surface with the parking brake locked. Make sure the transmission is in neutral (90cc models).

1. Fold out the kick-start lever (A) on the lefthand side of the ATV.
2. Make sure the stop switch is in the RUN position and turn the key to ON.
3. Place your foot on the kick-start, and then thrust your heel downward to crank the engine.
4. After the engine has started, fold the kick-start lever back into place. **NOTE:** A 10/12mm wrench is provided in the tool kit for removing or installing the lever. If not installed, make sure the rubber cap is installed on the kick-start shaft to protect the rider. On 50cc models, store the kick-start lever under the seat (B) when it's not installed on the ATV.

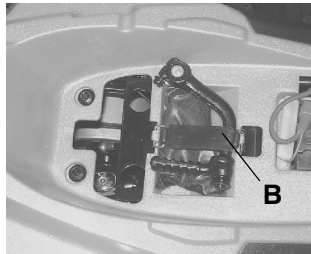
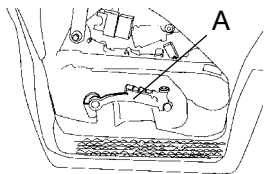

Features and Controls

Footwell Riser

The removeable footwell risers on the Predator 50 improve riding ergonomics and provide comfort for shorter operators. An operator will also have better control of the ATV when both feet can remain firmly planted on either the footwells or the risers. If the operator's legs are long enough to comfortably reach the footwells without the risers, the risers can be removed.

1. Remove the rubber caps (A) covering the screw access holes.
2. Remove the six screws (B) and nuts securing the footwell riser (C) to the footwell and remove the riser.
3. Reverse the procedure to reinstall the footwell riser for shorter operators.

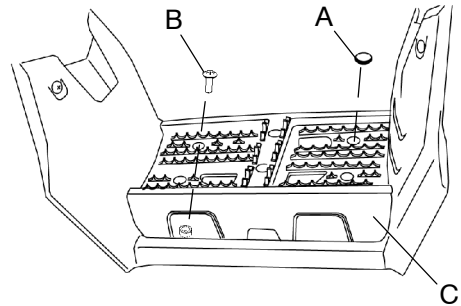

Break-in Period

The break in period for your new Polaris ATV is the length of time it takes to use the first tank of gas. No single action on your part is as important as following the procedures for a proper break-in. Careful treatment of a new engine will result in more efficient performance and longer life for the engine. Perform the following procedures carefully.

CAUTION

Excessive heat build-up during the first three hours of operation will damage close-fitted engine parts. Do not operate at full throttle or high speeds for extended periods during the first three hours of use.

Use of any lubricants other than those recommended by Polaris may cause serious engine damage. We recommend the use of Polaris lubricants for your vehicle.

1. Mix 6.4 ounces of recommended oil to two gallons of gasoline in an appropriate gas container and fill the fuel tank as outlined on pages 83-84. **NOTE:** After the break-in period the oil injection system provides the necessary engine lubrication without the need for pre-mixed fuel.

Break-in Period

2. Fill the oil tank with Polaris-recommended oil. **NOTE:** Always be sure to top off the oil level whenever refueling.
3. Drive slowly at first. Select an open area that allows room to familiarize yourself with vehicle operation and handling.
4. Vary the throttle positions. Do not operate at sustained idle.
5. Perform regular checks on fluid levels, controls and areas outlined on the daily pre-ride inspection. See page 90.
6. After the first tank of pre-mixed fuel has been used, check to see if the oil level in the oil tank has dropped, indicating that the oil pump is functioning properly. If the level has not dropped, see your dealer for oil pump bleeding and then repeat the pre-mix procedure.

Daily Pre-Ride Inspection

WARNING

If a proper inspection is not done before each use, severe injury or death could result. Always inspect the ATV before each use to ensure it's in proper operating condition.

Use the following checklist to make sure the ATV is in proper working condition before each use.

1. Tires - Check condition and pressures.
2. Fuel and oil tanks - Fill both tanks.
3. All brakes - Check operation/adjustment.
4. Throttle - Check for free operation and proper closing.
5. Brakelight - Check for proper operation.
6. Daytime running lights (if equipped) - Check for proper operation.
7. Engine stop switch - Check for proper function.
8. Wheels - Check for tightness of wheel nuts and axle nuts; check that axle nuts are secured by cotter pins.
9. Drive chain - Condition and slack; refer to drive chain adjustment.
10. Air cleaner element - Check for dirt; clean or replace.
11. Steering - Check for free operation noting any unusual looseness in any area.
12. Loose parts - Visually inspect vehicle for any damaged components or loose nuts/bolts or fasteners.
13. Riding gear - Wear a helmet, goggles and protective clothing.

Starting the Engine

WARNING

Engine exhaust contains poisonous carbon monoxide and can cause loss of consciousness resulting in severe injury or death. Never run an engine in an enclosed area.

CAUTION

Operating the ATV immediately after starting could cause engine damage. Allow the engine to warm up for several minutes before operating.

1. Shift the transmission to neutral (90cc models).
2. Set the parking brake and turn the fuel tank valve to ON.
3. Sit on the vehicle and attach the tether strap to the ATV and to your right wrist.

NOTE: The choke is fully on when the lever is pushed completely to the left. The choke is off when the lever is pushed completely to the right. The choke can be adjusted gradually, depending on how much choke is needed for starting.

Starting the Engine

4. If the engine is cold, use full choke by pushing the choke lever all the way to the left. A warm engine will not require the use of the choke.
5. Turn the engine stop switch to RUN, then turn the ignition key to ON. **NOTE:** Do not press the throttle while starting the engine.
6. Squeeze the rear brake lever and press the starter button.
NOTE: The rear brake lever must be engaged or the engine won't start.
7. Activate the starter for a maximum of five seconds, releasing the button when the engine starts. If it doesn't start, release the starter, wait five seconds, then activate for another five seconds. Repeat until the engine starts.
8. If the engine slows or stops, position the choke lever half way to allow proper engine warm up. Vary the RPM slightly with the throttle to aid in warm up.
9. When the engine idles smoothly, push the choke lever all the way to the right.

Stopping the Engine

1. Release the throttle completely and brake to a complete stop.
2. Put the shift lever into neutral (90cc models).
3. Lock the parking brake.



WARNING

A rolling vehicle can cause property damage and serious injury. Always apply the parking brake after stopping the engine.

Driving Safely

Safe Riding Gear

Always wear clothing suited to the type of riding. ATV riding requires special protective clothing for comfort and to reduce the chance of injury.

1. Helmet

Your helmet is the most important piece of protective gear for safe riding. A helmet can prevent a severe head injury.

Select an approved helmet that meets or exceeds your state's safety standards and bears either the Department of Transportation (DOT) label, the American National Standards Institute label (ANSI z90.1), or the Snell Memorial Foundation label.

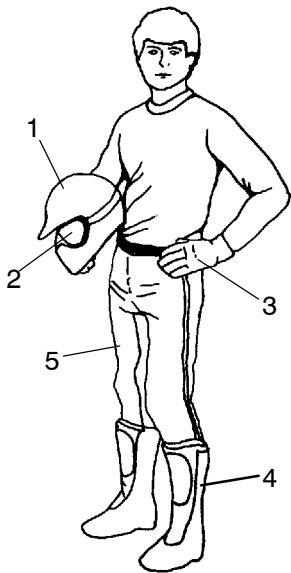

2. Eye Protection

Do not depend on sunglasses for proper eye protection. A pair of goggles or a helmet face shield offer the best protection for your eyes. They should be kept clean and be of shatterproof design (bearing the markings z2.1 or VESC 8).

3. Gloves

Off-road style gloves with knuckle pads are the best for comfort and protection.

4. Boots

The best footwear is a pair of strong over-the-calf boots with heels, like moto-cross boots.

5. Clothing

Always wear long sleeves and long pants to protect arms and legs. Riding pants with kneepads and a jersey with shoulder pads provide the best protection.

Driving Safely

Driving Procedure

1. Sit upright with both feet on the footrests and both hands on the handlebars.
2. Place the transmission in neutral (90cc models).
3. Start the engine and allow it to warm up.
4. Check your surroundings and determine your path of travel.
5. Squeeze the brake levers.
6. Shift the transmission to the desired gear (90cc models).
7. Release the parking brake and slowly release the brake levers.
8. Slowly depress the throttle with your right thumb and begin driving.
9. Drive slowly and practice turning and using the throttle and brakes on level surfaces.

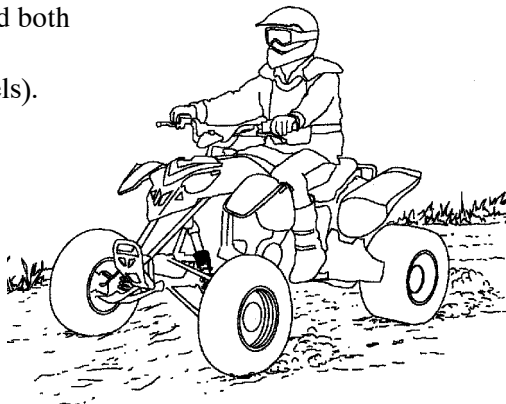

Making Turns

Your ATV is equipped with a solid rear axle, which drives both rear wheels equally at all times. This means that the wheel on the outside of the turn must travel a greater distance than the inside wheel when turning and the inside tire must slip traction slightly. To turn, steer in the direction of the turn, leaning your upper body to the inside of the turn while supporting your weight on the outer footrest. This technique alters the balance of traction between the rear wheels, allowing the turn to be made smoothly.

NOTE: Practice making turns at slow speeds.

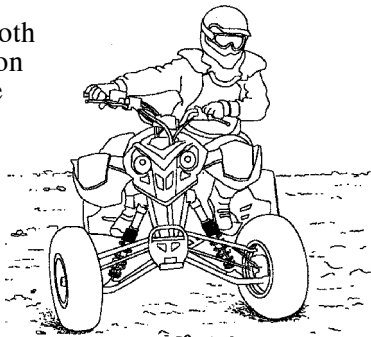

WARNING

Turning at sharp angles or at excessive speeds can result in vehicle overturn and lead to serious injury. Avoid turning at sharp angles. Never turn at high speeds.

Driving Safely

Driving on Slippery Surfaces

WARNING

Failure to exercise care when operating on slippery surfaces can result in loss of tire traction and cause loss of control, accident, and serious injury or death.

Never apply the brakes during a skid.

Do not operate on excessively slippery surfaces.

Always reduce speed and use additional caution.

Driving Safely

Whenever riding on slippery surfaces such as wet trails or loose gravel, or during freezing weather, follow these precautions:

1. Slow down when entering slippery areas.
2. Maintain a high level of alertness, reading the trail and avoiding quick, sharp turns, which can cause skids.
3. Correct a skid by turning the handlebars in the direction of the skid and shifting your body weight forward.

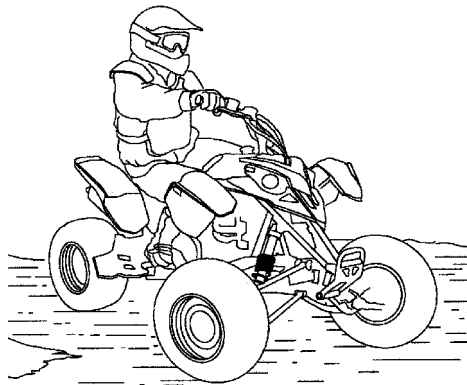

Driving Safely

Driving Uphill

WARNING

Braking and handling are greatly affected when operating in hilly terrain. Improper procedure could cause loss of control or overturn and result in serious injury or death.

Avoid climbing steep hills (15° maximum).

Use extreme caution when operating on hills, and follow proper operating procedures outlined in the owner's manual.

Driving Safely

Whenever traveling uphill, follow these precautions:

1. Always travel straight uphill.
2. Avoid steep hills (15° maximum).
3. Keep both feet on the footrests.
4. Transfer your weight forward.
5. Proceed at a steady rate of speed and throttle opening.
6. Remain alert and be prepared to take emergency action. This may include quick dismounting of the vehicle.

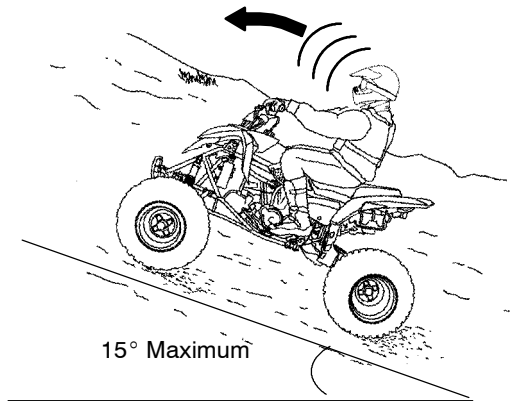

Driving Safely

Driving Across Hillsides

WARNING

Improperly crossing hills or turning on hills can result in loss of control or vehicle overturn, resulting in severe injury or death. Avoid crossing the side of a hill when possible. Follow proper procedures as outlined in the owner's manual.

Driving Safely

Sidehilling can be a dangerous type of driving and should be avoided if at all possible. If you do enter into a situation where sidehilling is necessary, follow these precautions:

1. Slow down.
2. Lean into the hill, transferring your upper body weight uphill while keeping your feet on the footrests.
3. Steer slightly into the hill to maintain direction.

NOTE: If the vehicle begins to tip, quickly turn the front wheel downhill, if possible, or dismount on the uphill side *immediately!*

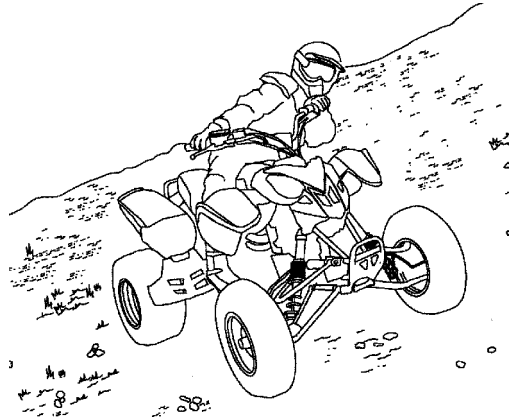

Driving Safely

Turning Around on a Hill

WARNING

Improper hill climbing procedures could cause loss of control or overturn and result in serious injury or death.

Avoid climbing steep hills (15° maximum).

Use extreme caution when operating on hills, and follow proper operating procedures outlined in the owner's manual.

If the vehicle stalls while climbing a hill, never back it down the hill! One maneuver that can be used when it's necessary to turn around while climbing a hill is the K-turn:

1. Stop and lock the parking brake while maintaining body weight uphill.
2. Shift the transmission to neutral (90cc models).
3. Shut off the engine.
4. Dismount on the uphill side of the vehicle, or on the left if the vehicle is pointing straight uphill.

Driving Safely

5. Staying uphill of the ATV, turn the handlebars full left.
6. While holding the brake, release the parking brake lock and slowly release the brake, allowing the ATV to roll around to your right until it's pointing across the hill or slightly downward.
7. Lock the parking brake and remount the ATV from the uphill side, maintaining body weight uphill.
8. Restart the engine.
9. Squeeze the rear brake lever.
10. Shift the transmission to forward gear (90cc models).
11. Release the parking brake and *drive slowly*, controlling speed with the rear brake, until the ATV is on more level ground.

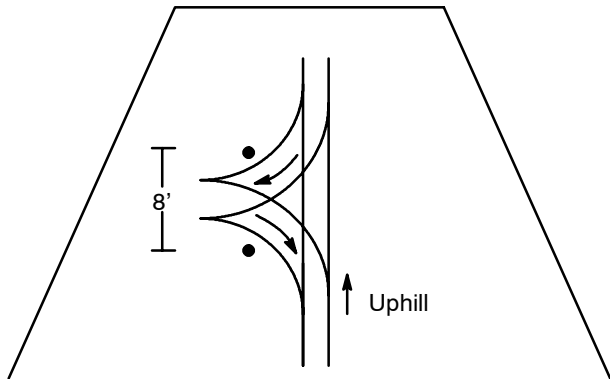

Driving Safely

Driving Downhill

Whenever descending a hill, follow these precautions:

1. Drive directly downhill.
2. Transfer your weight to the rear of the vehicle.
3. Slow down.
4. Apply the front and rear brakes at the same time, and very slightly, to aid in slowing.

WARNING

Excessive speed can cause loss of control and lead to serious injury or death. Always operate slowly when traveling downhill.

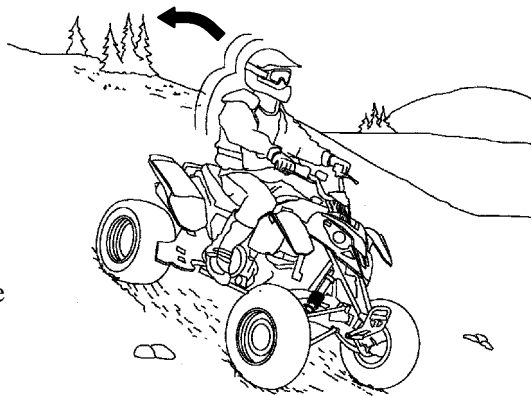

Parking on a Hill or Incline

Avoid parking on a hill or incline if possible. If it's unavoidable, follow these precautions:

1. Turn the engine off.
2. Set the parking brake.
3. Always block the rear wheels on the downhill side as shown in the illustration.
4. Shut off the fuel supply.

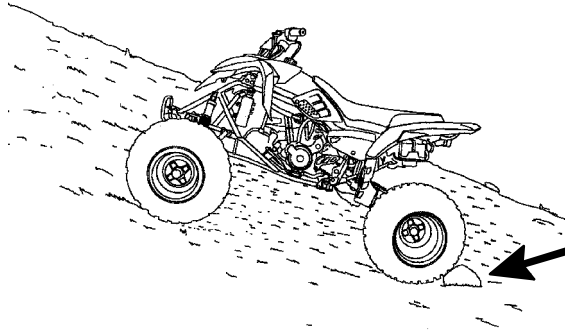

Driving Safely

Driving Through Water

Your ATV can safely operate through shallow water. The recommended maximum depth for your ATV is *below* the bottom of the footrests (A). Follow these procedures when operating through water:

1. Determine water depths before driving through water.
2. If crossing a stream, choose a crossing where both banks have gradual inclines.
3. Proceed slowly, avoiding rocks and obstacles if possible.
4. After driving through water, dry the brakes by applying light pressure to the levers until braking action is normal. If you do not perform this procedure, your brakes may be ineffective.

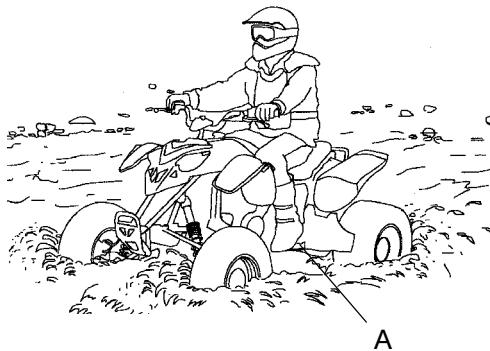

Driving Safely

Avoid operating your ATV through deep or fast flowing water. If the ATV is operated in deeper water than recommended, it's *critical* to have it serviced as outlined in the maintenance chart beginning on page 122. The following areas need special attention: engine oil, gearcase oil, front and rear gearcases and all grease fittings.

CAUTION

Major engine damage can result from driving this ATV in deeper water than recommended. If your vehicle becomes immersed or is operated in water that exceeds the bottom of the footrests, take it to your dealer for service before starting the engine.

Driving Safely

Driving Over Obstacles

Be alert! Look ahead and learn to read the terrain you're traveling on. Be constantly alert for hazards such as logs, rocks and low hanging branches.

WARNING

Severe injury or death can result if your vehicle comes in contact with a hidden obstacle. Not all obstacles are immediately visible. Travel with caution in unfamiliar terrain.

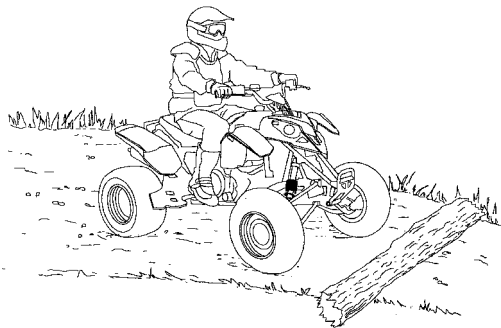

Driving in Reverse (90cc models)

Follow these guidelines when operating in reverse:

1. Back slowly.
2. Apply the brakes lightly for stopping.
3. Avoid turning at sharp angles.
4. Always avoid backing downhill.
5. Never open the throttle suddenly while backing.
6. Always look left, right and behind the ATV before backing.

WARNING

Failure to use caution when operating in reverse can result in serious injury or death. Before shifting into reverse, always check for obstacles or people behind the vehicle and follow the reverse operation procedures outlined in this manual. Always back slowly.

Hauling Cargo

The Sportsman 90 was designed to carry a certain amount of load. Never exceed the weight capacities listed in the specifications section of the owner's manual. Never carry cargo on a Scrambler.

Cargo weight should be evenly distributed (1/3 on the front rack and 2/3 on the rear rack) and mounted as low as possible. When operating over rough or hilly terrain, reduce speed and cargo weight to maintain stable driving conditions.

WARNING

Hauling cargo improperly can alter vehicle handling and may cause loss of control or brake instability and result in serious injury or death. Always heed the warnings on the following pages.

Hauling Cargo



- **REDUCE SPEED AND ALLOW GREATER DISTANCE FOR BRAKING WHEN CARRYING CARGO.**
- **CARGO WEIGHT DISTRIBUTION** should be 1/3 on the front rack and 2/3 on the rear rack. When operating over rough or hilly terrain, reduce speed and cargo to maintain stable driving conditions. Carrying loads on one rack only increases the possibility of vehicle tip over.
- **HEAVY LOADS CAN CAUSE BRAKING AND CONTROL PROBLEMS.** Use extreme caution when applying brakes with a loaded vehicle. Avoid terrain or situations which may require backing downhill.

(continued on following page)

Hauling Cargo

- **ALL LOADS MUST BE SECURED BEFORE MOVING VEHICLE.** Unsecured loads can create unstable operating conditions, which could result in loss of control of the vehicle.
- **LOADS MUST BE CARRIED AS LOW ON THE RACKS AS POSSIBLE.** Carrying loads high on the racks raises the center of gravity of the vehicle and creates a less stable operating condition. When cargo loads are carried high on the racks, the weight of the loads must be reduced to maintain stable operating conditions.
- **OPERATE ONLY WITH STABLE AND SAFELY ARRANGED LOADS.** When handling off-centered loads which cannot be centered, securely fasten load and operate with extra caution.
- **EXTREME CAUTION MUST BE USED** when operating with loads extending over the rack sides. Stability and maneuverability may be adversely affected, causing the machine to overturn.
- **DO NOT TRAVEL FASTER THAN THE RECOMMENDED SPEEDS.**

Emission Control Systems

Noise Emission Control System

Do not modify the engine, intake or exhaust components, as doing so may affect compliance with state and local noise level requirements.

Spark Arrestor

Your Polaris ATV is not equipped with a spark arrestor approved by the USDA Forest Service. Operating this ATV on U.S. public lands without a spark arrestor is in violation of federal law.

Maintenance

PVT System

WARNING

The PVT system rotates at high speeds, creating large amounts of force on clutch components. Extensive engineering and testing has been conducted to insure the safety of this product. However, as the owner you have the following responsibilities to make sure this system remains safe:

Do not modify any component of the PVT system. Doing so may reduce its strength so that a failure may occur at high speeds. This system has been precision balanced. Any modification will cause the system to be out of balance, creating vibration and additional loads on components.

- Routine maintenance is the responsibility of the owner. Always follow recommended maintenance procedures. See your dealer!
- This PVT system is intended for use on Polaris products only.
- The PVT housing must be securely in place during operation.

Failure to comply with this warning can result in severe injury or death.

PVT System

If the ATV is operated in dusty areas, clean the PVT filter more often than recommended for normal conditions. To clean the PVT filter:

1. Remove the screws and the crankcase cover.
2. Remove the screws and the filter cover.
3. Soak the filter in a mild detergent and rinse with clean water.
4. Allow the filter to air dry, then reinstall.

CAUTION

Exposure to salt water will cause corrosion to metal components. If your vehicle is operated in salt water areas, rinse it off frequently with fresh water.

Maintenance

Battery

The battery in your Polaris ATV is a sealed battery. The sealing strip cannot be removed. *Never add water to this type of battery.*

Keep the battery terminals and connections free of corrosion. If cleaning is necessary, remove the corrosion with a stiff wire brush. Wash with a solution of one tablespoon baking soda and one cup water. Rinse well with tap water and dry off with clean shop towels. Coat the terminals with dielectric grease or petroleum jelly.

WARNING

Improperly connecting or disconnecting battery cables can result in an explosion and cause serious injury or death. When removing the battery, always disconnect the negative (black) cable first. When reinstalling the battery, always connect the negative (black) cable last.

Battery

Battery Removal

1. Disconnect the hold-down straps securing the electrical box and battery in position.
2. Disconnect the black (negative) battery cable first.
3. Disconnect the red (positive) battery cable next.
4. Lift the battery out of the ATV.

Maintenance

Battery

Battery Installation and Connections

1. Set the battery in its holder.
2. Connect and tighten the red (positive) cable first.
3. Connect and tighten the black (negative) cable last.
4. Attach the hold-down strap.
5. Verify that cables are properly routed.

NOTE: When installing a new battery, make sure it's fully charged prior to its initial use. Using a new battery that has not been fully charged can damage the battery and result in a shorter life. It can also hinder vehicle performance. If recharging is necessary, use a .5 amp battery charger.

Battery Storage

When the vehicle is placed in storage for three months or more, the battery should be removed, stored out of the sun in a cool, dry place and tested monthly. Before reusing, take the battery to your dealer for testing and recharging on a .5 amp battery charger.

Periodic Maintenance Schedule

To help you perform routine maintenance, a tool kit is provided in the storage compartment under the seat. Items included in the kit are:

- Spark plug wrench
- Screwdriver
- Tire pressure gauge

Maintenance intervals are based upon average riding conditions and an average vehicle speed of approximately 10 miles per hour. Vehicles subjected to severe use, such as operation in wet or dusty areas, should be inspected and serviced more frequently.

Inspect, clean, lubricate, adjust and replace parts as necessary. When inspection reveals the need for replacement parts, use genuine Polaris parts available from your Polaris dealer.

NOTE: Service and adjustments are critical. If you're not familiar with safe service and adjustment procedures, have a qualified dealer perform these operations.

Maintenance

Periodic Maintenance Schedule

Hours of operation are based on a 10 mph average. If service is due at 20 hours, the equivalent odometer reading would be 200 miles. Perform all services at whichever reading is reached first.

WARNING

Improperly performing the procedures marked with a ■ could result in component failure and lead to serious injury or death. Have an authorized Polaris dealer perform these services.

Maintenance Chart Key

- ▶ Perform these operations more often under severe use, such as in dirty or wet conditions, to purge water or dirt contamination from grease fittings and other critical components.
- Dealer service item.

Maintenance

Periodic Maintenance Schedule

	Item to Inspect	Hours/ Miles	Frequency	Remarks
	Brake System	Pre-ride	Pre-ride	Inspect
	Tires	Pre-ride	Pre-ride	Inspect
	Wheels	Pre-ride	Pre-ride	Inspect
	Frame nuts, bolts, fasteners	Pre-ride	Pre-ride	Inspect; tighten any loose hardware
	Throttle	Pre-ride	Pre-ride	Check for proper operation
	Engine stop switch	Pre-ride	Pre-ride	Check for proper operation
	Engine oil	Pre-ride	Pre-ride	Check level; fill oil when refueling
▶	Air Filter	Pre-ride	Pre-ride	Inspect; clean
▶	Steering	Pre-ride	Pre-ride	Check for free operation
▶	Drive Chain	Pre-ride	Pre-ride	Inspect
■	Brake pad wear	10 hrs	Monthly	Inspect periodically
	Battery	20 hrs	Monthly	Inspect terminals; clean

Maintenance

Periodic Maintenance Schedule

	Item to Inspect	Hours/ Miles	Frequency	Remarks
	Oil Pump Cable	50 hrs	6 months	Inspect; adjust; lubricate; replace if required
	Carburetor Float Bowl	50 hrs	6 months	Drain bowl periodically and prior to storage
■	Throttle Cable/ETC Switch	50 hrs	6 months	Inspect; adjust; lubricate; replace if necessary
▶	Steering	50 hrs	6 months	Inspect; lubricate
▶	Rear Axle	50 hrs	6 months	Inspect bearings; lubricate
▶	Drive Chain	50 hrs	6 months	Inspect; adjust and lubricate if needed
▶	Front Suspension	50 hrs	6 months	Inspect; lubricate; tighten fasteners
▶	Rear Suspension	50 hrs	6 months	Inspect; tighten fasteners
■	Clutches (drive and driven)	100 hrs	12 months	Inspect; clean
	Engine Mounts	100 hrs	12 months	Inspect

Maintenance

Periodic Maintenance Schedule

	Item to Inspect	Hours/ Miles	Frequency	Remarks
	Spark Plug	100 hrs	12 months	Inspect; replace if necessary
■	Ignition Timing	100 hrs	12 months	Inspect; adjust as needed
■	Fuel System	100 hrs	12 months	Check for leaks at tank cap, lines, fuel valve, filter, pump and carburetor. Replace lines every two years.
■	Fuel Filter	100 hrs	12 months	Replace annually
■	Front wheel bearings	300 hrs	36 months	Inspect; replace if necessary
■	Idle Speed	As needed	As needed	Adjust
■	Toe adjustment	As needed	As needed	Inspect periodically adjust when parts are replaced

Maintenance

Lubrication Recommendations

Item	Lube	Method	Frequency
1. Engine Oil	Polaris VES II Synthetic 2-cycle	Fill oil tank.	As needed and when refueling
2. Gearcase Oil Level	AGL Synthetic gearcase lube	See Page 146.	Change annually or at 100 hrs. Maintain in SAFE range.
3. Drive Chain	Polaris chain lube or SAE 80/90	Lubricate as required and before each ride in wet conditions.	As required
4. Front A-Arm	▶ ★ Grease	Locate fittings and grease.	Every 3 months or 50 hrs.

▶ Grease more often under severe use, such as wet or dusty conditions.

★ Use Polaris Premium all Season Grease or grease conforming to NLGI No. 2.

Lubrication Recommendations

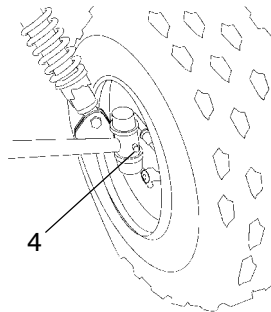
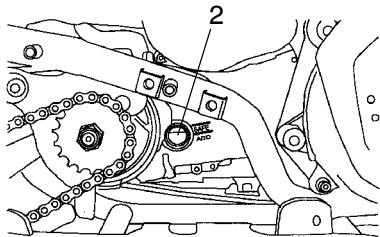

90cc Models

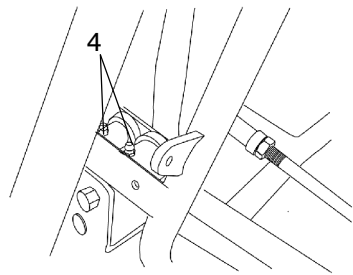

50cc Models

Maintenance

Lubrication Recommendations

Polaris 2-Cycle Lubricants

Polaris Premium 2-cycle lubricants are the most advanced formulation of oils, specifically designed for today's 2-cycle engines. These oils provide additives for 2-cycle engines that are lacking in today's fuel. These additives keep ring grooves cleaner for less ring sticking and improved overall engine cleanliness. We recommend the use of these oils for all Polaris 2-cycle engines.

Polaris premium 2-cycle oils will mix with each other, but we recommend that you choose only one of the oils and use it exclusively through the life of the unit. Never mix Polaris 2-cycle oils with any other brand of oil, including Polaris Nature Oil Biodegradable oil. Their incompatibility could result in engine damage. See page 168 for the part numbers of Polaris products.

Lubrication Recommendations

Polaris VES II Synthetic 2-Cycle Oil

Your ATV has been primed with VES II synthetic oil. We recommend the continued use of this oil. It's been formulated for low smoke, low odor, low deposits and high lubricity.

Premium 2-Cycle Oil

Polaris Premium Gold Synthetic 2-Cycle Oil is also suitable for use.

Maintenance

Periodic Maintenance Record

Use the following chart to record periodic maintenance.

Maintenance Interval Performed	Servicing Date	Servicing Dealer or Person	Remarks
First 5 hrs.			
25 hrs.			
50 hrs.			
75 hrs.			
100 hrs.			

Maintenance

Periodic Maintenance Record

Maintenance Interval Performed	Servicing Date	Servicing Dealer or Person	Remarks

Maintenance

Rear Spring Adjustment

The rear shock absorber spring is adjusted by rotating the adjuster (A) in the direction required to increase or decrease spring tension.

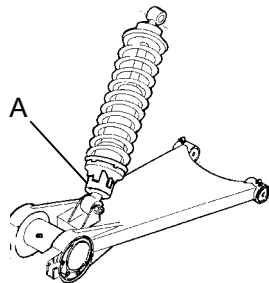

Handlebar Adjustment

⚠ WARNING

Improper adjustment of the handlebars or incorrect torquing of the adjuster block tightening bolts can cause limited steering or loosening of the handlebars, resulting in loss of control and possible serious personal injury or death. Follow the adjustment procedures exactly, or see your Polaris dealer for service.

Handlebar Adjustment

The handlebars can be adjusted for rider preference.

1. Remove the pod to access the handlebar bolts.
2. Loosen the four bolts (A).
3. Adjust the handlebar to the desired height. Be sure the handlebars do not hit the gas tank or any other part of the machine when turned fully to the left or right.
4. Lightly tighten each bolt equally to prevent uneven gaps in the block.
5. Torque the handlebar adjuster block bolts to 7.3 ft. lbs. (10 Nm).

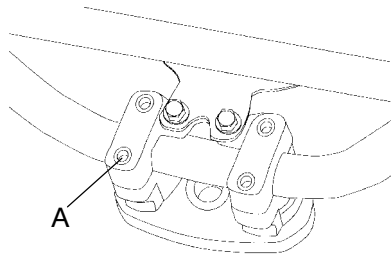

Maintenance

Axle and Wheel Nut Torque Specifications

Check the following nuts occasionally and when they've been loosened for maintenance.

Specification	
Front Spindle Nuts	42-45 ft. lbs. (57-61 Nm)
Rear Spindle Nuts	78-81 ft. lbs. (106-110 Nm)

NOTE: All nuts with a cotter pin installed must be serviced by an authorized Polaris dealer.

Front Wheel Hub Tightening

Front wheel bearing tightness and spindle nut retention are critical component operations. All service must be performed by your authorized Polaris dealer.

Speed Control Systems

Per ANSI / SVIA-1-2001 (sec. 6.1.3) AS DELIVERED TO THE CONSUMER, the speed of youth models is restricted to *under* 10 MPH for the 50 cc models and *under* 15 MPH for the 90 cc models.

The dealer CANNOT, under any circumstances, either prior to the sale or later, even at the consumer's request, remove or adjust any speed limiting devices.

Polaris Youth ATVs have an electronic speed control system and an adjustable throttle limiting screw. These speed limiting devices may be adjusted/removed *only by consumers* when they determine that their child is capable of handling the additional speed.

Per ANSI / SVIA-1-2001 (sec. 6.2) the *unrestricted* top speed is less than 15 MPH for the 50 cc models and less than 30 MPH for the 90 cc models.

Maintenance

Speed Control Systems

Electronic Speed Control System

Your Polaris ATV has a speed control system that controls engine RPM and speed of the ATV.

Adjust speed by removing or installing the jumper on the CDI (A). With the jumper installed, 50cc models will travel no faster than 10 mph and 90cc models will travel no faster than 15 mph. With the jumper removed, 50cc models will travel no faster than 15 mph and 90cc models will travel no faster than 30 mph.

Jumper Removal and Installation

1. Remove the CDI and its rubber mounting strap from the mounting tab located on the frame bulkhead near the steering post. It can be accessed through the left (90cc models) or right (50cc models) front fender.
2. Remove the two screws (B) from the jumper to remove or install the jumper, then reinstall the screws.
3. Reinstall the CDI and mounting strap onto the mounting tab.

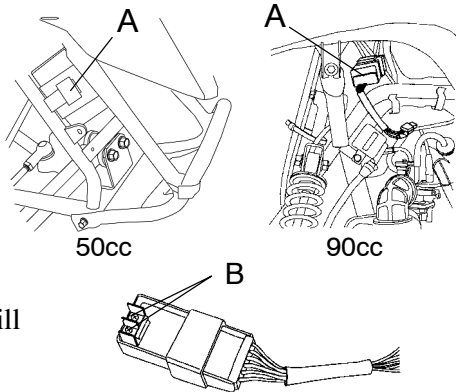

Speed Control Systems

Throttle Stop Speed Control System

Adjusting speed at the CDI is the recommended method of speed control, but the throttle stop system may also be used. Use the following procedure to control how far the throttle opens.

1. Loosen the jam nut (A)
2. Turn the screw (B) inward to reduce speed or outward to increase speed.
3. Tighten the jam nut after adjusting.

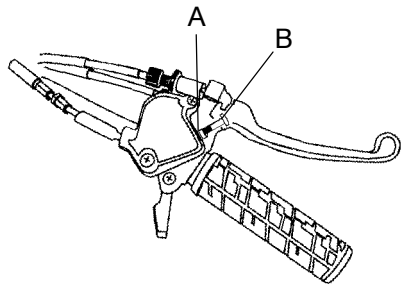

Maintenance

Steering Inspection

The steering assembly of the ATV should be checked periodically for loose nuts and bolts. If any are found, have your dealer tighten them before operating the ATV.

Toe Alignment

WARNING

Severe injury or death can result from improper toe alignment and adjustment. Do not attempt to adjust tie rod alignment. All tie rod adjustments should be performed by an authorized Polaris dealer.

Use the following procedure to check the toe alignment of the vehicle. The recommended toe alignment is 1/8" to 1/4" toe out.

1. Set the handlebars in a straight-ahead position. **NOTE:** The steering frog can be used as an indicator of whether the handlebars are straight. The frog should always point straight back from the steering post.
2. Place stands (A) in front of the vehicle, perpendicular to the rear tires. See illustration.

Toe Alignment

3. Tie an elastic string around the stands, making sure the string just touches the side surface of the rear tires on each side of the vehicle and goes around the stands in front of the vehicle (B).
4. Measure the distance from the string to the rim at the front and rear of the front rim (C). Rear measurement should be $1/16'' - 1/8''$ (.2 to .3 cm) more than the front measurement.

NOTE: If you discover improper alignment, see your Polaris dealer for service.

Camber and Caster

The camber and caster are non-adjustable.

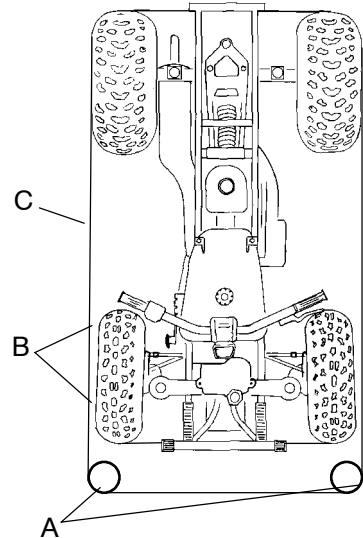

Maintenance

Throttle Cable Adjustment

Always check the throttle for smooth operation before riding. Periodically check the throttle freeplay. It should be kept between $1/16''$ and $1/8''$ (1.5mm - 3.2mm) (A). If adjustment is required, turn the adjustment nut (B) until the freeplay falls in to the acceptable limit.

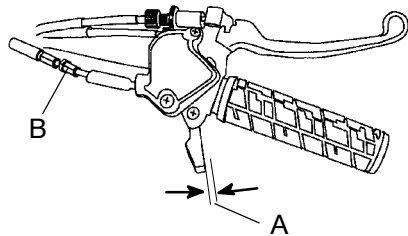

Brake Freeplay

Brake Freeplay Specifications		
Model	Front	Rear
Predator 50	.1" - .39" (2.5-9.9 mm)	.15" - .30" (3.8-7.6 mm)
Predator 90	.40" - .80" (10-20 mm)	.40" - .80" (10-20 mm)
Sportsman 90	.40" - .80" (10-20 mm)	.40" - .80" (10-20 mm)

Maintenance

Brake Adjustment

Periodically check (measure) the freeplay of the front and rear brakes (A). Refer to the specifications chart on page 140 for the acceptable range of freeplay.

To adjust the front brake freeplay, turn the adjustment knob (B). To adjust the rear brake freeplay, turn the adjuster nut (C).

Brake Lever Travel

Service the brakes when brake lever travel (D) reaches the following total lever travel measurements. Always service the brakes when there is no longer sufficient stopping ability at the specified lever travel setting.

Component	Total Lever Travel
Front brake lever	1 3/4" (45mm)
Rear brake lever	2 1/2" (65mm)

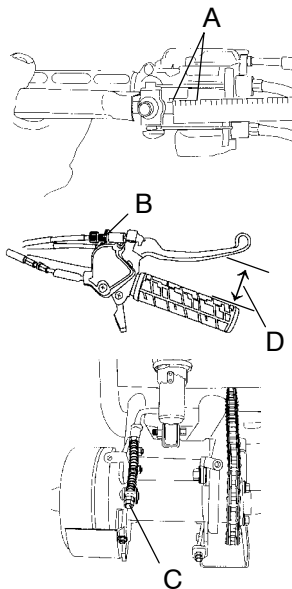

Maintenance

Air Cleaner

Inspect the air filter weekly or after every 50 hours of operation. If the ATV is ridden in wet or dusty conditions, clean the filter more often.

1. Remove the screws (A) on the airbox and remove the filter (B).
2. Soak the filter in a mild detergent and rinse it in clean water.
3. Let the filter air dry and reinstall.

CAUTION

Never operate the ATV with the filter element removed. Dirt will enter the engine causing serious rapid wear and damage to the engine.

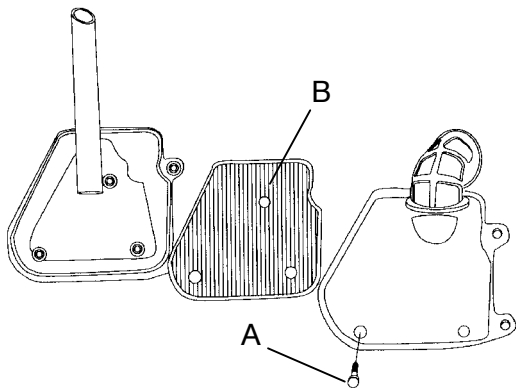

Carburetor Adjustments

Your Polaris ATV is calibrated at the factory for optimal performance at altitudes ranging from zero to 6,000 feet (1800 m) and temperatures of +40 degrees F. (4 degrees C.) or higher.

Above 6000 feet (1800 m) the engine air/fuel mixture becomes overly rich and the engine loses approximately 3% of its power for each 1000-foot (304.8 m) increase in elevation. Although this power cannot be regained, adjustments to the carburetor and drive system can be made to allow more efficient operation.

Optional jets, available from your Polaris dealer, are required for operation above 6,000 feet and temperatures below +40 degrees F. (4 degrees C.) **NOTE:** Continuous operation of the engine without proper jetting when required can cause poor performance, overheating or engine damage. See your Polaris dealer for more information about jetting the ATV for conditions in your area.

Maintenance

Spark Plugs

- Use NGK BP7HS or NGK BPR7HS spark plugs.
- Proper electrode gap is .24”-.28” (0.6-0.7 mm).
- Spark plug torque is 14 ft. lbs. (19 Nm).

Spark plug condition is indicative of engine operation. The spark plug firing end condition should be read after the engine has been warmed up and the vehicle has been driven at higher speeds. Immediately check the spark plug for correct color.

CAUTION

Using non-recommended spark plugs can result in serious engine damage. Always use Polaris-recommended spark plugs.



WARNING

A hot exhaust system and engine can cause serious burns. Wear protective gloves when removing a spark plug for inspection.

Spark Plugs

NORMAL: The normal insulator tip is gray, tan or light brown. There will be few combustion deposits. The electrodes are not burned or eroded. This indicates the proper type and heat range for the engine and the service. **NOTE:** The tip should not be white. A white insulator tip indicates overheating, caused by use of an improper spark plug or incorrect carburetion adjustments.

WET FOULED: The wet fouled insulator tip is black. A damp oil film covers the firing end. There may be a carbon layer over the entire nose. Generally, the electrodes are not worn. General causes of fouling are excessive oil, use of non-recommended oil, improper use of the choke, or incorrect carburetion adjustments.

Spark Plug Removal and Replacement

1. Remove the spark plug cap.
2. Using the special wrench provided in the tool pouch, rotate the spark plug counterclockwise to remove.
3. Reverse the procedure for spark plug installation. Torque to 14 ft. lbs. (19 Nm).

Maintenance

Cylinder Head/Cylinder Base Fastener Torque

Have your dealer check the ATV cylinder head and cylinder base fasteners for proper torque at the first service or after 25 hours.

Gearcase Lubrication

The gearcase fill plug (A) is located on the top of the gearcase. The sight glass (B) is on the righthand side of the gearcase. The oil level must be maintained in the safe zone of the sight glass. It should be checked monthly and changed annually.

With the ATV on a level surface, check the oil level through the sight glass. If the level is low, add AGL Synthetic Gearcase Lubricant. See page 168 for the part numbers of Polaris products.

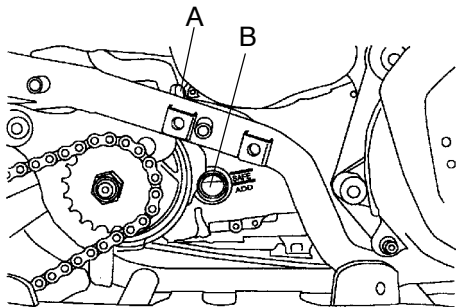

Gearcase Oil Change

1. Remove the fill plug.
2. Remove the gearcase drain plug and drain the oil into a drain pan. Dispose of properly.
3. Clean and reinstall the drain plug. Torque to 14 ft. lbs. (19 Nm).
4. Add AGL Synthetic Gearcase Lubricant to the safe zone in the sight glass.

Model	Total Capacity	Capacity at Oil Change
50cc Models	10 oz. (300 ml)	7 oz. (200 ml)
90cc Models	20.25 oz. (600 ml)	16.25 oz. (480 ml)

5. Replace the fill plug and check for leaks.

Maintenance

WARNING

Operating your ATV with worn tires, improperly inflated tires, non-standard tires or improperly installed tires will affect vehicle handling and could cause an accident resulting in serious injury or death.

Maintain proper tire pressure as described on the decal on your ATV and in the owner's manual.

Always use original equipment size and type when replacing tires.

Make sure the wheels are installed properly.

Always replace tires when the tread depth measures 1/8" (.3 cm) or less.

Tire Tread Depth

Always replace tires when tread depth is worn to 1/8" (.3 cm) or less. See illustration.

Wheel Removal

1. Stop the engine and lock the parking brake.
2. Loosen the wheel nuts slightly.
3. Elevate the side of the vehicle by placing a suitable stand under the footrest frame.
4. Remove the wheel nuts and remove the wheel.

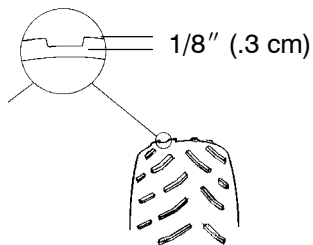

Maintenance

Wheel Installation

1. With the park brake locked, place the wheel in the correct position on the wheel hub. Be sure the valve stem is toward the outside and rotation arrows on the tire point toward forward rotation.
2. Install the wheel bolts (A) and finger tighten them.
3. Lower the vehicle to the ground.
4. Securely tighten the bolts to 22 ft. lbs. (30 Nm).

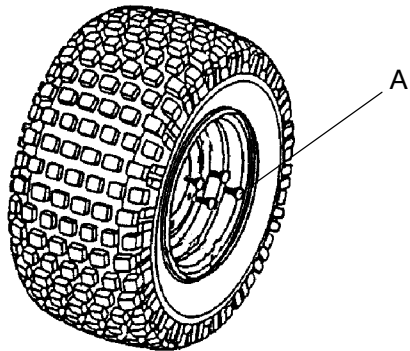

Drive Chain Inspection and Adjustment

Regularly lubricate the drive chain with Polaris chain spray lube or an approved chain lube. See page 168 for the part numbers of Polaris products.

CAUTION

Washing the drive chain with a high pressure washer or gasoline can cause premature wear and drive chain failure. Don't use a high pressure washer or gasoline to clean the drive chain.

CAUTION

Adjusting or operating the ATV with improper rear drive chain slack can result in severe damage to the transmission and drive components. Always make sure the slack is within the stated specifications.

Maintenance

Drive Chain Inspection and Adjustment (90cc Models)

1. Check the amount of chain slack by moving the vehicle slightly forward to gain slack at the top side of the chain.
2. Collapse the suspension with an adjustable (buckle type) trailer tie down. Fasten the strap (A) around the axle and rear bumper tube.
3. Tighten the strap until a straight line (B) can be drawn from the rear axle to the gearcase output shaft intersecting the swing arm pivot. This establishes the tightest chain position.
4. Pull down on the chain tensioner (C) to move it out of the way, then measure chain slack. It should have 1/4"-1/2" (6-12 mm) deflection.
5. If the chain needs adjustment, use the procedure on page 154.

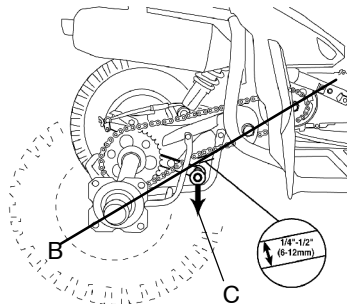
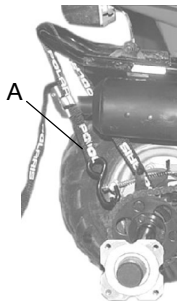

Drive Chain Inspection and Adjustment (50cc Models)

1. Check the amount of chain slack by moving the vehicle slightly forward to gain slack at the top side of the chain.
2. The chain should have 1/4"-1/2" (6-12 mm) deflection. If the chain needs adjustment, use the procedure on page 154.

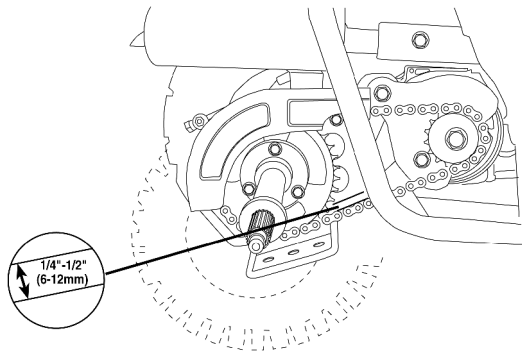

Maintenance

Drive Chain Slack Adjustment

CAUTION

Hold the adjuster stud securely while tightening the jam nuts to avoid breaking the stud.

1. Loosen the four rear housing mount bolts (A).
2. Loosen the chain adjuster lock nut.
3. Turn the chain adjuster (B) clockwise to 1/4"-1/2" (6-12 mm) deflection.
4. Tighten the chain adjuster lock nut to 84 in. lbs. (9.4 Nm).
5. Tighten the four rear housing mount bolts to 43 ft. lbs. (60 Nm).

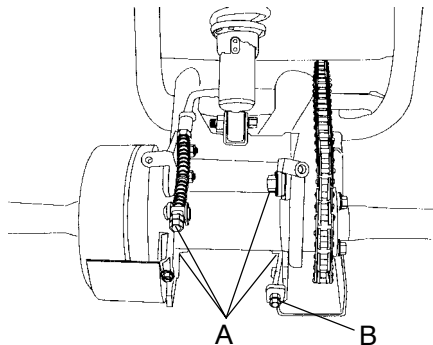

Brakelight Lamp Replacement

If the brakelight doesn't work, the lamp may need to be replaced.

1. From the rear of the brakelight, remove the two screws (A) holding the lens cover in place and remove the lens cover (B).
2. Remove the lamp (C) and replace it with a new recommended lamp.
3. Test the brakelight to ensure operation.
4. Reinstall the lens cover.

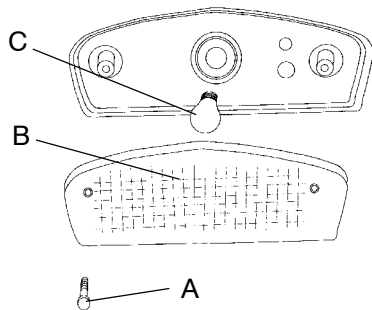

Maintenance

Indicator Light Lamp Replacement

1. Remove the handlebar cover or pod to access the lamps.
2. Use a needle-nose pliers to pinch the tangs and remove the lamp.
3. Apply dielectric grease to the socket and install the new lamp.
4. Reinstall the cover or pod.

Daytime Running Lights Lamp Replacement (if equipped)

If the daytime running lights do not operate, replace the lamps. Polaris recommends that you install replacement lamps obtained from your authorized Polaris dealer.

1. **Predator 90:** Locate the lamp socket below the front cover. Rotate the socket counterclockwise about 1/4 turn and remove it from the housing.
Sportsman 90: Remove the light housing from the bumper. Separate the housing by removing the four screws from the rear cover. Rotate the lamp socket counterclockwise about 1/4 turn and remove it from the housing.
2. Without twisting, pull the lamp out of the socket.
3. Install the new lamp.
4. Reinstall the socket into the housing and rotate clockwise about 1/4 turn.
5. Start the engine to make sure the lights come on. If the lights do not operate, see your Polaris dealer for service.
6. Reinstall any remaining components.

Maintenance

Cleaning and Storage

Keeping your ATV clean will not only improve its appearance but it can also extend the life of various components. With a few precautions, your ATV can be cleaned much like an automobile.

Washing the ATV

The best and safest way to clean your ATV is with a garden hose and a pail of mild soap and water. Use a professional type washing mitt, cleaning the upper body first and the lower parts last. Rinse with water frequently and dry with a chamois to prevent water spots. **NOTE:** If warning and safety labels are damaged, contact your a Polaris dealer for free replacement.

Polaris does not recommend the use of a high pressure type car wash system for washing the ATV. If a high pressure system is used, exercise extreme care to avoid water damage to the wheel bearings, transmission seals, body panels, brakes and warning labels.

NOTE: Grease all zerk fittings immediately after washing, and allow the vehicle to run for a while to evaporate any water that may have entered the engine or exhaust system.

Cleaning and Storage

Waxing the ATV

Your ATV can be waxed with any non-abrasive automotive paste wax. Avoid the use of harsh cleaners since they can scratch the body finish.

CAUTION

Certain products, including insect repellants and chemicals, will damage plastic surfaces. Use caution when using these products near plastic surfaces.

Maintenance

Cleaning and Storage

Storing the ATV

Proper preparation of the engine and fuel system is vital to the prevention of rust and corrosion on engine parts. Whenever the machine is stored for a period of more than 60 days, the engine must be fogged. Use Polaris fogging oil and follow the directions on the can.

Always add a fuel conditioner/stabilizer to the fuel tank before storage. Run the engine for five minutes to get the additives through the entire fuel system and then top off with fuel.

Fuel additive products are available through your Polaris dealer.

NOTE: Jet restriction caused by improper storage can cause lean conditions and very poor slow speed driving quality.

Cleaning and Storage

Transporting the ATV

Follow these procedures when transporting the ATV.

1. Turn the fuel valve off.
2. Be sure the fuel cap, oil cap and seat are installed correctly and securely.
3. Tie the frame of the ATV to the transporting unit securely using suitable straps or rope.
4. Lock the parking brake.

Accessories

Polaris has a wide range of accessories available for your ATV. See your Polaris dealer.

Specifications

Predator 50	
Rider Capacity/Maximum Weight	1 Rider/90 lbs. (41 kg)
Displacement	49cc
Carburetion	H68K
Cooling	Air Cooled
Engine type	2-Stroke
Lubrication	Oil Injected
Oil Capacity	20 oz. (.6 liter)
Fuel Capacity	1 gallon (3.8 liters)
Starting	Electric with kick-start backup
Drive System	Automatic CVT
Final Drive	Chain
Front Suspension	Single control arm with 3" (7.6 cm) of travel
Rear Suspension	Spring over shock with 3" (7.6 cm) of travel

Specifications

Predator 50	
Front/Rear Brakes	Drum
Parking Brake	Mechanical Lock
Front Tires	16 x 6.5 - 7 (3 psi)
Rear Tires	16 x 8 - 7 (3 psi)
Turning Radius (inside tire)	60" (152 cm)
Wheel Base	33" (84 cm)
Ground Clearance	4" (10 cm)
Dry Weight	185 lbs. (84 kg)
Length/Width/Height	48" (10 cm) / 31.5" (122 cm) / 28" (71 cm)
Brake Light	Standard
Low Oil Light	Standard

Specifications

Predator 90	
Rider Capacity/Maximum Weight	1 Rider/165 lbs. (75 kg)
Displacement	89cc
Carburetion	H68K
Cooling	Fan Cooled
Engine type	2-Stroke
Lubrication	Oil Injected
Oil Capacity	1.1 quarts (1 liter)
Fuel Capacity	1.3 gallons (5 liters)
Starting	Electric with kick-start backup
Drive System	Automatic CVT
Final Drive	Chain
Front Suspension	A-arm with 4.25" (10.8 cm) travel
Rear Suspension	Spring over shock with 5" (12.7 cm) of travel

Specifications

Predator 90	
Front/Rear Brakes	Drum
Parking Brake	Mechanical Lock
Front Tires	19 x 7 - 8 (3 psi)
Rear Tires	18 x 9.5 - 8 (3 psi)
Turning Radius (inside tire)	70" (178 cm)
Wheel Base	38.5" (98 cm)
Ground Clearance	5" (12.7 cm)
Dry Weight	262 lbs. (119 kg)
Length/Width/Height	57" (145 cm) / 35.75" (91 cm) / 36.1" (91.8 cm)
Brake Light	Standard
Low Oil Light	Standard

Specifications

Sportsman 90	
Rider Capacity/Maximum Weight	1 Rider/165 lbs. (75 kg)
Displacement	89cc
Carburetion	H68K
Cooling	Fan Cooled
Engine type	2-Stroke
Lubrication	Oil Injected
Oil Capacity	1.1 quarts (1 liters)
Fuel Capacity	1.32 gallons (5 liters)
Starting	Electric with kick-start backup
Drive System	Automatic CVT
Final Drive	Chain
Front Suspension	A-arm with 5" (12.7 cm) of travel
Rear Suspension	Spring over shock with 4.25" (10.8 cm) of travel

Specifications

Sportsman 90	
Front Rack Capacity	10 lbs. (4.5 kg)
Rear Rack Capacity	20 lbs. (9 kg)
Front/Rear Brakes	Drum
Parking Brake	Mechanical Lock
Front Tires	19 x 7 - 8 (3 psi)
Rear Tires	18 x 9.5 - 8 (3 psi)
Wheel Base	38.5" (98 cm)
Ground Clearance	5" (12.7 cm)
Turning Radius (inside tire)	70" (177 cm)
Dry Weight	276 lbs. (125 kg)
Length/Width/Height	59.75" (151.8 cm) / 35.75" (90.8 cm) / 36.6" (93 cm)
Brake Light	Standard
Low Oil Light	Standard

Polaris Products

Part No.	Description
Engine Lubricant	
2870791	Fogging Oil (12 oz. Aerosol)
2874438	VES II Synthetic 2-Cycle Oil (qt.)
2871721	Premium Gold Synthetic 2-Cycle Oil (qt.)
2871098	Premium 2-Cycle Engine Oil (qt.)
Gearcase / Transmission Lubricants	
2873602	Premium AGL Synthetic Gearcase Lubricant (qt.)
2871653	Premium ATV Angle Drive Fluid (8 oz.)
2871654	Premium Demand Drive Hub Fluid (8 oz.)
Coolant	
2871323	60/40 Coolant (gal.)
2871534	60/40 Coolant (qt.)

Polaris Products

Part No.	Description
Grease / Specialized Lubricants	
2871312	Grease Gun Kit, Premium All Season (3 oz.)
2871322	Premium All Season Grease (3 oz. cartridge)
2871423	Premium All Season Grease (14 oz. cartridge)
2871460	Starter Drive Grease (2 oz.)
2871515	Premium U-Joint Lube (3 oz.)
2871551	Premium U-Joint Lube (14 oz.)
2871329	Dielectric Grease (Nyogel™)
2872073	Chain Lube, Aerosol (6.25 oz.)
2872348	Chain Lube, Aerosol (16 oz.)
Additives / Miscellaneous	
2871326	Carbon Clean Plus (12 oz.)
2870652	Fuel Stabilizer (16 oz.)
2870990	DOT3 Brake Fluid (12 oz.)
2872893	Engine Degreaser (12 oz.)

Troubleshooting

See your Polaris dealer if you're unable to identify solutions using the following charts.

Engine Turns Over, Fails to Start

Possible Cause	Solution
Out of fuel	Turn fuel valve to reserve, refuel
Clogged fuel valve or filter	Inspect and clean or replace
Water is present in fuel	Drain the fuel system and refuel
Fuel valve is turned off	Turn the fuel valve on
Old or non-recommended fuel	Replace with new fuel
Fouled or defective spark plug(s)	Inspect plug(s), replace if necessary
No spark to spark plug	Inspect plug(s), verify stop switch is on
Crankcase filled with water or fuel	Immediately see your Polaris dealer
Clogged fuel filter	Replace the filter
Low battery voltage	Recharge battery with .5 amp charger
Mechanical failure	See your Polaris dealer

Troubleshooting

Engine Doesn't Turn Over

Possible Cause	Solution
Low battery voltage	Recharge battery with .5 amp charger
Loose battery connections	Check all connections and tighten
Loose solenoid connections	Check all connections and tighten

Engine Pings or Knocks

Possible Cause	Solution
Poor quality or low octane fuel	Replace with recommended fuel
Incorrect ignition timing	See your Polaris dealer
Incorrect spark plug gap or heat range	Set gap to specs or replace plugs

Troubleshooting

Engine Backfires

Possible Cause	Solution
Weak spark from spark plugs	Inspect, clean and/or replace spark plugs
Incorrect spark plug gap or heat range	Set gap to specs or replace plugs
Old or non-recommended fuel	Replace with new fuel
Incorrectly installed spark plug wires	See your Polaris dealer
Incorrect ignition timing	See your Polaris dealer
Mechanical failure	See your Polaris dealer

Troubleshooting

Engine Runs Irregularly, Stalls or Misfires

Possible Weak Spark Cause	Solution
Fouled or defective spark plugs	Inspect, clean and/or replace spark plugs
Worn or defective spark plug wires	See your Polaris dealer
Incorrect spark plug gap or heat range	Set gap to specs or replace plugs
Loose ignition connections	Check all connections and tighten
Water present in fuel	Replace with new fuel
Low battery voltage	Recharge battery with .5 amp charger
Kinked or plugged fuel vent line	Inspect and replace
Incorrect fuel	Replace with recommended fuel
Clogged air filter	Inspect and clean or replace
Electronic throttle control malfunction	See your Polaris dealer
Other mechanical failure	See your Polaris dealer

Troubleshooting

Engine Runs Irregularly, Stalls or Misfires

Possible Lean Fuel Mixture Cause	Solution
Low or contaminated fuel	Add or change fuel, clean the fuel system
Low octane fuel	Replace with recommended fuel
Clogged fuel filter	Replace filter
Incorrect jetting	See your Polaris dealer
Possible Rich Fuel Mixture Cause	Solution
Overuse of choke	Inspect, clean and/or replace spark plugs
Fuel is very high octane	Replace with lower octane fuel
Incorrect jetting	See your Polaris dealer

Troubleshooting

Engine Stops or Loses Power

Possible Cause	Solution
Out of fuel	Turn fuel valve to reserve, refuel
Kinked or plugged fuel vent line	Inspect and replace
Water present in fuel	Replace with new fuel
Fouled or defective spark plugs	Inspect, clean and/or replace spark plugs
Worn or defective spark plug wires	See your Polaris dealer
Incorrect spark plug gap or heat range	Set gap to specs or replace plugs
Loose ignition connections	Check all connections and tighten
Low battery voltage	Recharge battery with .5 amp charger
Incorrect fuel	Replace with recommended fuel
Clogged air filter	Inspect and clean or replace
Electronic throttle control malfunction	See your Polaris dealer
Other mechanical failure	See your Polaris dealer

Warranty

LIMITED WARRANTY

Polaris Sales Inc., 2100 Highway 55, Medina, MN 55340, gives a SIX MONTH LIMITED WARRANTY on all components of the Polaris All Terrain Vehicle (ATV) against defects in material or workmanship. Polaris also gives a one year limited warranty on the final drive chain for failure due to defects. This warranty covers the parts and labor charges for repair or replacement of defective parts which are covered by this warranty. This warranty begins on the date of purchase. This warranty is transferrable to another consumer during the warranty period through a Polaris dealer.

REGISTRATION

At the time of sale, the Warranty Registration Form must be completed by your dealer and submitted to Polaris within ten days. Upon receipt of this registration, Polaris will record the registration for warranty. **THE PURCHASER MUST COMPLETE AN ATV SAFETY TRAINING COURSE PROVIDED BY THE DEALER IN ORDER TO HAVE VALID WARRANTY ON THE ATV.** No verification of registration will be sent to the purchaser as the copy of the Warranty Registration Form will be the warranty entitlement. If you have not signed the original registration and received the “customer copy”, please contact your dealer immediately. **NO WARRANTY COVERAGE WILL BE ALLOWED UNLESS YOUR ATV IS REGISTERED WITH POLARIS.**

Initial dealer preparation and set-up of your ATV is very important in ensuring trouble-free operation. Purchasing a machine in the crate or without proper dealer set-up will void your warranty coverage.

WARRANTY COVERAGE AND EXCLUSIONS:

LIMITATIONS OF WARRANTIES AND REMEDIES

The Polaris limited warranty excludes any failures that are not caused by a defect in material or workmanship. This warranty does not cover accidental damage, normal wear and tear, abuse or improper handling. This warranty also does not cover any ATV that has been altered structurally, modified, neglected, improperly maintained, used for racing, or used for purposes other than for which it was manufactured, or for any damages which occur during trailer transit or as a result of unauthorized service or the use of unauthorized parts. In addition, this warranty does not cover physical damage to paint or finish, stress cracks, tearing or puncturing of upholstery material, corrosion, or defects in parts, components or the ATV due to fire, explosions or any other cause beyond Polaris' control.

This warranty does not cover the use of unauthorized lubricants, chemicals, or fuels that are not compatible with the ATV. The exclusive remedy for breach of this warranty shall be, at Polaris' exclusive option, repair or replacement of any defective materials, or components or products. **THE REMEDIES SET FORTH IN THIS WARRANTY ARE THE ONLY REMEDIES AVAILABLE TO ANY PERSON FOR BREACH OF THIS WARRANTY. POLARIS SHALL HAVE NO LIABILITY TO ANY PERSON FOR INCIDENTAL, CONSEQUENTIAL OR SPECIAL DAMAGES OF ANY DESCRIPTION, WHETHER ARISING OUT OF EXPRESS OR IMPLIED**

WARRANTY OR ANY OTHER CONTRACT, NEGLIGENCE, OR OTHER TORT OR OTHERWISE. Some states do not permit the exclusion or limitation of incidental or consequential damages or implied warranties, so the above limitations or exclusions may not apply to you if inconsistent with controlling state law.

Warranty

WARRANTY COVERAGE AND EXCLUSIONS:

LIMITATIONS OF WARRANTIES AND REMEDIES

ALL IMPLIED WARRANTIES (INCLUDING BUT NOT LIMITED TO THE IMPLIED WARRANTIES OF MERCHANTABILITY AND FITNESS FOR A PARTICULAR PURPOSE) ARE LIMITED IN DURATION TO THE ABOVE SIX MONTH WARRANTY PERIOD. POLARIS FURTHER DISCLAIMS ALL EXPRESS WARRANTIES NOT STATED IN THIS WARRANTY. Some states do not allow limitations on how long an implied warranty lasts, so the above limitation may not apply to you if inconsistent with controlling state law.

HOW TO OBTAIN WARRANTY SERVICE

If your ATV requires warranty service, you must take it to a Polaris dealer authorized to repair Polaris ATVs. When requesting warranty service you must present your copy of the Warranty Registration form to the dealer. (THE COST OF TRANSPORTATION TO AND FROM THE DEALER IS YOUR RESPONSIBILITY). Polaris suggests that you use your original selling dealer; however, you may use any Polaris Servicing Dealer to perform warranty service.

Please work with your dealer to resolve any warranty issues. Should your dealer require any additional assistance they will contact the appropriate personnel at Polaris.

This warranty gives you specific legal rights, and you may also have other rights which vary from state to state.

If any of the above terms are void because of state or federal law, all other warranty terms will remain in effect.

Recommended Lubricants

1. Mixing oil brands or using non-recommended oil may cause engine damage. We recommend the use of Polaris engine oil.
2. Damage resulting from the use of non-recommended lubricants may not be covered by warranty.

Warranty

EXPORTED VEHICLES

EXCEPT WHERE SPECIFICALLY REQUIRED BY LAW, THERE IS NO WARRANTY OR SERVICE BULLETIN COVERAGE ON THIS VEHICLE IF IT IS SOLD OUTSIDE THE COUNTRY OF THE SELLING DEALER'S AUTHORIZED LOCATION.

This policy does not apply to vehicles that have received authorization for export from Polaris Industries. Dealers may not give authorization for export. You should consult an authorized dealer to determine this vehicle's warranty or service bulletin coverage if you have any questions.

This policy does not apply to vehicles registered to government officials or military personnel on assignment outside the country of the selling dealer's authorized location.

This policy does not apply to Safety Recalls.

How to Get Service

In the country where your vehicle was purchased:

Warranty or Service Bulletin repairs must be done by an authorized Polaris dealer. If you move or are traveling within the country where your vehicle was purchased, Warranty or Service Bulletin repairs may be requested from any authorized Polaris dealer who sells the same line as your vehicle.

Outside the country where your vehicle was purchased:

If you are traveling temporarily outside the country where your vehicle was purchased, you should take your vehicle to an authorized Polaris dealer. You must show the dealer photo identification from the country of the selling dealer's authorized location as proof of residence. Upon residence verification, the servicing dealer will be authorized to perform the warranty repair.

EXPORTED VEHICLES

How to Get Service

If You Move:

If you move to another country, be sure to contact Polaris Customer Assistance and the customs department of the destination country before you move. Vehicles importation rules vary considerably from country to country. You may be required to present documentation of your move to Polaris Industries in order to continue your warranty coverage. You may also be required to obtain documentation from Polaris Industries in order to register your vehicle in your new country.

If Purchased From A Private Party:

If you purchase a Polaris product from a private citizen outside of the country in which the vehicle was originally purchased, all warranty coverage will be denied.

Notice

If your vehicle is registered outside of the country where it was purchased, and you have not followed the procedure set out above, your vehicle will no longer be eligible for warranty or service bulletin coverage of any kind. (Vehicles registered to Government officials or military personnel on assignment outside of the country where the vehicle was purchased will continue to be covered by the basic warranty.)

For questions call Polaris Customer Assistance:

United States: 1-763-417-8650

Canada: 1-204-925-7100

Index

A

- Air Cleaner 142
- Axle and Wheel Nut Torque Specs . 134

B

- Battery 118-120
- Battery Installation 120
- Battery Removal 119
- Battery Storage 120
- Brake Adjustment 141
- Brake Freeplay 140
- Brake Freeplay Specifications 140
- Brake Lever Travel 141
- Brake Levers 22
- Brakelight Lamp Replacement 155
- Brakes 78-80
- Break-in Period 88-89

C

- Camber and Caster 139
- Carburetor Adjustments 143
- Chain Adjustment 154
- Choke Lever 72
- Cleaning and Storage 158-161
- Controls 71-87
- Cylinder Head Torque 146

D

- Daily Pre-Ride Inspection 90
- Daytime Running Lights 159
- Drive Chain Adjustment 151-153
- Driver Warnings 47-69
- Driving Across Hillside 102
- Driving Downhill 106
- Driving in Reverse 111
- Driving on Slippery Surfaces 98
- Driving Over Obstacles 110
- Driving Procedure 96
- Driving Safely 94-111
- Driving Through Water 108
- Driving Uphill 100

E

- Electronic Speed Control System .. 136
- Emission Control Systems 115
- Engine Start Button 73
- Engine Stop Switch 72
- Equipment Modifications 15

F

- Features 71-87
- Footwell Riser 87
- Front Wheel Hub Tightening 134
- Fuel Filter 85

F

- Fuel System 83-85
- Fuel Valve 85

G

- Gas Cap 21, 84
- Gearcase Lubrication 146
- Gearcase Oil Change 147

H

- Handlebar Adjustment 133
- Hauling Cargo 112-114
- Horn Button 19, 72

I

- Ignition Switch 23
- Indicator Lamp Replacement 156
- Indicator Lights 81

K

- K-Turn 104
- Kick Start 20
- Kick Start Lever 86
- Know Your ATV 18-24

Index

L-M

Lamp Replacement	
Brakelights	155
Daytime Running Lights	157
Indicator Lights	156
Lights	81
Lubricants, 2-Cycle	128
Lubrication Recommendations	126-129
Main Switch	71
Maintenance	116-161
Maintenance Chart Key	122
Maintenance Record	130-131
Maintenance Schedule	121-125
Making Turns	97

N-O

Noise Emission Control System	115
Oil	128
Oil System	82
Oil Tank	82

P

Parking Brake	79
Parking Brake	80
Parking on a Hill or Incline	107
Polaris Products	168-169
Pre-Ride Check	25-27
PVT System	116-117

R

Rear Spring Adjustment	132
Recommended Lubricants	179
Riding Rules	28-31

S

Safety	7-15
Safety Decals	34-45
Safety Training	7
Seat Latch	21
Shift Lever (90cc models)	20, 76
Signal words	8
Spark Arrestor	115
Spark Plug Removal	145
Spark Plug Replacement	145
Spark Plugs	144-145
Specifications	162-167
Speed Control Systems	135-137
Start Button	73
Starting the Engine	91-92
Steering Inspection	138
Stop Switch	19, 72
Stopping the Engine	93
Storing the ATV	160
Symbols	8

T

Table of Contents	5
Tether Strap	23
Throttle	19, 74-75
Throttle Cable Adjustment	140
Throttle Stop Speed Control System	137
Tires	149
Toe Alignment	138-139
Transporting the ATV	161
Troubleshooting	170-175
Turning Around on a Hill	104

U-V

Understanding Warnings	32
Vehicle Identification Numbers	70

W

Warnings	7
Warranty	176-181
Washing the ATV	158
Waxing the ATV	159
Welcome	3-4
Wheel Installation	150
Wheel Removal	149