



THE NEW AMERICAN MOTORCYCLE™

2008

VEGAS®

VEGAS LOW™

VEGAS 8-BALL™

KINGPIN®

KINGPIN® TOUR

KINGPIN 8-BALL™



For your nearest Polaris dealer, call 1-800-POLARIS  
or visit [www.polarisindustries.com](http://www.polarisindustries.com)  
Polaris Sales Inc., 2100 Hwy 55, Medina, MN 55340  
Phone 1-888-704-5290  
Part No. 9921239 Rev 02  
Printed in USA

**California Proposition 65 Warning**

This product contains or emits  
chemicals known to the state of  
California to cause cancer and birth  
defects or other reproductive harm.

## **We've created a web site just for YOU!**

- Technical tips
- New product introductions
- Event schedules
- Parts and Service Manual information
- Exciting details about The Way Out

**Check it out...**

**[www.victory-usa.com](http://www.victory-usa.com)**



**POLARIS®**  
**The Way Out.**





The text, photographs and illustrations used in this manual are based on the most current product information available at the time of publication. Product improvements or other changes may result in differences between this manual and the motorcycle. Polaris Industries reserves the right to make production changes at any time, without notice and without incurring any obligation to make the same or similar changes to motorcycles previously built.



**2008 OWNER'S MANUAL**  
**Vegas<sup>®</sup> Kingpin<sup>®</sup>**  
**Vegas Low<sup>™</sup> Kingpin<sup>®</sup> Tour**  
**Vegas 8-Ball<sup>™</sup> Kingpin 8-Ball<sup>™</sup>**

P/N 9921239

**VICTORY Motorcycle Division, Polaris Industries Inc.**  
**2100 Highway 55, Medina, Minnesota 55340-9800 Phone: 1-888-704-5290**

Copyright© 2007 Polaris Sales Inc. All rights reserved.

POLARIS, POLARIS THE WAY OUT, FREEDOM, VEGAS, KINGPIN and VICTORY MOTORCYCLES are registered trademarks of Polaris Industries Inc.  
VEGAS 8-BALL, VEGAS LOW and KINGPIN 8-BALL are trademarks of Polaris Industries Inc.  
DUNLOP is a registered trademark of Dunlop Tire Corporation. LOCTITE is a registered trademark of LOCTITE Corporation.  
Features of VICTORY motorcycles are covered by U.S. Patent Nos.:  
6,976,691; 6,407,663; D489670; D482311; D482304; D481980; D481973; D474142

# FOREWORD

Thank you for choosing a Polaris VICTORY motorcycle!

Some of the photographs and illustrations used in the manual are generalizations, so your model may be slightly different than what is shown.

If you misplace or damage your owner's manual, you should purchase a replacement copy from an authorized VICTORY dealer. This manual should be considered part of the motorcycle, and it should remain with the motorcycle when it's sold.

If you have questions about the operation or maintenance of the motorcycle after you've read this manual, please contact an authorized VICTORY dealer. To locate the nearest authorized VICTORY dealer, call 1-800-POLARIS and provide the area code or zip code of your location. Visit [www.polarisindustries.com](http://www.polarisindustries.com) for a listing of authorized VICTORY dealers by state, zip code or area code.

Your authorized VICTORY dealer will resolve all issues regarding your motorcycle. If you're not satisfied with the performance of your VICTORY dealer, please contact the Polaris Consumer Service Department at 1-888-704-5290. In Canada, call 204-925-7100.

VICTORY motorcycles comply with all federal, state and local safety and emission regulations for the area of intended sale.

# TABLE OF CONTENTS

FOREWORD .....	2
INTRODUCTION .....	4
SAFETY .....	5
REPORTING SAFETY DEFECTS .....	30
COMPONENT IDENTIFICATION .....	31
INSTRUMENTS, FEATURES AND CONTROLS .....	39
PRE-OPERATION CHECK .....	50
OPERATION .....	67
MAINTENANCE .....	81
MAINTENANCE RECORD .....	86
CLEANING .....	144
STORAGE .....	150
WARRANTIES .....	154
SPECIFICATIONS .....	164
IDENTIFICATION NUMBERS .....	169
INDEX .....	170

# INTRODUCTION

## Read the Owner's Manual

Your VICTORY owner's manual contains information that's essential to safe riding and proper maintenance of the motorcycle. Anyone who uses the motorcycle (operators and passengers) must read the owner's manual before riding.

Carefully read and understand the information found in the safety section beginning on page 5. Understand and follow the procedures in your owner's manual to keep your VICTORY motorcycle in top condition on the road or in storage. Bring the manual with you when you ride. Following the precautions and procedures in the manual will add to your enjoyment and keep you riding safely.

### **WARNING**

**Failure to follow the safety precautions and operation and maintenance procedures outlined in this manual may result in death or injury (to you or your passenger) or damage to the motorcycle.**

---

## Symbols and Terms Used in the Owner's Manual

The following safety signal words and symbols appear throughout the owner's manual. Your safety and the safety of others are involved when these words and symbols are used. Become familiar with their meanings before reading the manual.



The safety alert symbol indicates a potential for personal injury to you or others.

### **WARNING**

The safety alert warning indicates a potential hazard that could result in serious injury or death.

---

### **Caution**

The safety alert caution indicates a potential hazard that may result in minor personal injury or damage to the motorcycle.

---

### **Caution**

A caution indicates a situation that may result in damage to the motorcycle.

---

**Notice** A notice highlights important information you must pay attention to.

# SAFETY

## Safe Riding Practices

### WARNING

**Improper use of this motorcycle can result in serious injury or death to you, your passenger and others. To minimize the risk of injury, read and understand the information contained in this section before operating the motorcycle. This section contains safety information specific to the VICTORY motorcycle, as well as information about general motorcycle safety. Anyone who uses the motorcycle (operators and passengers) must follow these safety precautions.**

---

Motorcycling has inherent risks. You can minimize those risks, but you can't eliminate them completely. Even if you're an experienced motorcycle operator or passenger, read all of the information in this safety section before operating the motorcycle.

- Your ability to safely operate the motorcycle depends on your judgment and your use of safe riding habits. Take a rider education course from the Motorcycle Safety Foundation or another qualified instructor. The course will help you develop or refresh your expertise in safe riding habits through instruction and riding. For information on Motorcycle Safety Foundation rider education courses in your area, call 1-800-446-9227 or visit their homepage at <http://msf-usa.org>.
- Read and understand all information in this owner's manual. It contains safety information specific to individual components and operations.
- Pay close attention to the motorcycle maintenance requirements in this manual. For additional information or assistance with technical services specified in the manual or required by mechanical circumstances, see the *VICTORY Service Manual* or your authorized VICTORY Dealer.

## Safe Riding Practices

The following design characteristics affect how you should ride the VICTORY motorcycle:

- Some models are designed for one rider and one passenger. Some models are designed for one rider only. Never carry a passenger on a vehicle designed for a single rider. Never carry more than one passenger on a vehicle designed for only one rider and one passenger.
- The motorcycle is designed for on-road use. Do not exceed the gross vehicle weight rating (see the specifications section, beginning on page 164, or the certification label on the steering head). Riding off-road or carrying weight exceeding the maximum weight rating can make handling difficult, which could cause loss of control.
- In the first 500 miles, operate the motorcycle according to the break-in procedures described on page 68. Operating the motorcycle without following break-in procedures can result in serious engine damage.
- Some VICTORY motorcycles include saddlebags, a windshield, and a passenger backrest as standard equipment. To maintain stability, be prepared to reduce the operating speed of motorcycles equipped with these accessories.



# SAFETY

## Safe Riding Practices

Follow these general safe riding practices:

- *Before each ride, make the checks described in the Pre-Operation Check section beginning on page 50.* Operating the motorcycle without completing the pre-operation check may cause damage to the motorcycle or result in an accident.
- Until you're thoroughly familiar with the VICTORY motorcycle and all of its controls, practice riding where there is little or no traffic. Practice riding at a moderate speed on varying road surfaces and under varying weather conditions.
- *Know your skills and limits, and ride within them.*
- Allow only licensed, experienced operators to ride your motorcycle, and then only after they have become familiar with its controls and operation.
- Do not ride when you're fatigued or under the influence of alcohol, prescription drugs, over-the-counter drugs or any other drugs. Fatigue, alcohol and drugs can cause drowsiness, loss of coordination and loss of balance. They can also affect your awareness and judgment.
- If your motorcycle operates abnormally, correct the problem immediately (see the *VICTORY Service Manual* or contact your authorized VICTORY dealer). If you continue to operate a motorcycle in this condition, you are likely to aggravate the initial problem, increase the cost of repairs and threaten your safety.

## Safe Riding Practices

- The most common cause of accidents involving a motorcycle and an automobile is the automobile driver's failure to see the motorcycle. Ride defensively, as if you are invisible to other motorists, even in broad daylight. Ride where you're clearly visible to other motorists, and observe their behavior carefully, as they may not see or be aware of you.
- *Be especially cautious at intersections, as these are the most likely places for an accident.*
- To prevent loss of control while operating the motorcycle, keep your hands on the handlebars and your feet on the footrests.
- Obey the speed limit and adjust your speed and riding technique based on road, weather and traffic conditions. As you travel faster, the influence of all other conditions increases, which can affect the motorcycle's stability and increase the possibility of losing control.
- Do not move or operate the motorcycle with the steering locked (with accessory lock), as the severely restricted steering could result in loss of control.
- *Reduce your speed when:*
  - The road has potholes or is otherwise rough or uneven.
  - The road has sand, dirt, gravel or other loose substances on it.
  - The road is wet, icy or oily.
  - The road contains painted surfaces, manhole covers, metal grating, railway crossings or other slippery surfaces.

# SAFETY

## Safe Riding Practices

- *Reduce your speed when:*
  - The weather is windy, rainy or otherwise causing slippery or rapidly changing conditions.
  - The traffic is heavy, congested, not allowing sufficient space between vehicles or otherwise not flowing smoothly.
  - You are being passed in either direction by a large vehicle that produces a wind blast in its wake.
- *To maximize braking effectiveness, use the front and rear brakes together.* Improper braking may cause loss of control or may not slow the vehicle in time to avoid a collision. Be aware of the following braking facts and practices:
  - The rear brake provides 40% of the motorcycle's stopping power, at most.
  - Consider road conditions before applying the brakes. When the road is wet or rough, or contains loose or other slippery substances, apply the brakes gradually.
  - Bring the motorcycle to the upright position before applying the brakes, and avoid applying the brakes in a corner if at all possible. When the motorcycle is leaning through a corner, the amount of traction available for braking is reduced, increasing the possibility of the tires skidding when the brakes are applied.
- When approaching a curve, choose a speed and lean angle that allows you to pass through the curve in your own lane without applying the brakes. Excessive speed, improper lean angle or braking in a curve can cause loss of control.

## Safe Riding Practices

- Ground clearance is reduced when the motorcycle leans. Do not allow components to contact the road surface when leaning the motorcycle in a curve, as this could cause loss of control.
- Retract the sidestand fully before riding. If the sidestand is not fully retracted, it could contact the road surface and cause loss of control.
- Do not tow a trailer. Towing a trailer can make the motorcycle hard to handle, which could cause loss of control.

## Carrying a Passenger

**NOTE:** Some models are designed for a single rider only. Single-rider models are not equipped with a passenger seat or passenger footrests. DO NOT carry a passenger on motorcycles not properly equipped for a passenger.

To carry a passenger safely, do the following:

- Direct the passenger to hold onto you or the seat strap with both hands and to keep both feet on the passenger footrests. Do not carry a passenger who cannot place both feet firmly on the passenger footrests. A passenger who is not holding on properly, or who cannot reach the passenger footrests, can shift their body erratically, which can make the motorcycle hard to handle and cause loss of control.
- If necessary, adjust the rear shock absorber preload according to the instructions on page 100. Improper preload adjustment can make your motorcycle hard to handle and can cause loss of control.
- Before riding, be sure your passenger knows safe riding procedures. Discuss any safety information unfamiliar to your passenger. A passenger who is unaware of safe riding procedures may distract you or make movements that make the motorcycle hard to handle.
- Adjust your riding style to compensate for the differences in handling, acceleration and braking caused by the additional weight of the passenger. Failure to do so can cause loss of control.

# SAFETY

## Safe Riding Practices

### Protective Apparel

To decrease the risk of injury and increase riding comfort, wear protective riding apparel.

- Wearing a helmet can prevent a severe head injury. Always wear a helmet that meets or exceeds established safety standards. Approved helmets in the USA and Canada bear a U.S. Department of Transportation (DOT) label. *In accidents involving motorcycles, head injuries are the leading cause of motorcyclist fatalities, and statistics prove that an approved helmet is the most effective protection in preventing or reducing head injuries.*
- Wear eye protection. Some state laws require that you wear eye protection. Eye protection reduces the chance that your vision could be impaired by wind or by airborne particles and objects.
- You and your passenger should wear bright or light colored and/or reflective clothing to improve visibility to other motorists. *A motorist's failure to see or recognize a motorcycle is the leading cause of automobile/motorcycle accidents.*
- Wear gloves, a jacket, heavy boots and long pants to prevent or reduce abrasions, lacerations or burns should the motorcycle fall.
- Wear boots with low heels, as high heels can catch on pedals or footrests. The combination of boots and pants should completely cover legs, ankles and feet, protecting skin from engine and exhaust system heat. The engine and exhaust system get hot soon after the engine is started and stay hot for about half an hour after the engine is turned off.
- Do not wear loose, flowing clothing or long boot laces, as they can catch on handlebars, levers or footrests, or become entangled in the wheels, causing loss of control and serious injury.

## Gross Vehicle Weight Rating (GVWR)

Gross vehicle weight is the total combined weight of the motorcycle, the operator and the passenger. Examples of calculating GVWR are provided on the following pages.

Do not exceed the motorcycle's gross vehicle weight rating. Exceeding the weight rating can reduce stability and handling and could cause loss of control. Refer to the specifications section of this manual beginning on page 164 or the certification label on your motorcycle's steering head for model-specific GVWR information.

- The weight of the motorcycle includes the motorcycle and all of its fluids, any accessories and their contents, and any additional cargo on the motorcycle.
- The weight of the operator or passenger includes body weight, all apparel and objects in or on apparel.

# SAFETY

## Loading Examples

<b>EXAMPLE 1:</b> <b>VEGAS</b> <b>with no accessories or cargo.</b> <b>Gross Vehicle Weight Rating:</b> <b>1151 lbs (522 kg)</b>	Item	Weight
	Motorcycle with full capacity of all fluids	686 lbs (311 kg)
	Operator with recommended riding apparel	230 lbs (104 kg)
	Passenger with recommended riding apparel (passenger models)	165 lbs (75 kg)
	<b>Total Weight</b>	<b>1081 lbs (490 kg)</b>

<b>EXAMPLE 2:</b> <b>VEGAS</b> <b>with accessory saddlebags.</b> <b>Gross Vehicle Weight Rating:</b> <b>1151 lbs (522 kg)</b>	Item	Weight
	Motorcycle with full capacity of all fluids	686 lbs (311 kg)
	Weight of leather saddlebags and brackets	12 lbs (5.5 kg)
	Cargo (saddlebags at capacity)	14 lbs (6 kg)
	Operator with recommended riding apparel	230 lbs (104 kg)
	Passenger with recommended riding apparel (passenger models)	165 lbs (75 kg)
<b>Total Weight</b>	<b>1107 lbs (502 kg)</b>	

<b>EXAMPLE 3:</b> <b>VEGAS LOW</b> <b>with no accessories or cargo.</b> <b>Gross Vehicle Weight Rating:</b> <b>1134 lbs (514 kg)</b>	Item	Weight
	Motorcycle with full capacity of all fluids	679 lbs (308 kg)
	Operator with recommended riding apparel	230 lbs (104 kg)
	<b>Total Weight</b>	<b>909 lbs (412 kg)</b>

**NOTE:** As shown in Example 2, the weight of any accessory items (leather saddlebags and the brackets) *in addition* to the cargo, must be added to the base weight of the motorcycle. NEVER exceed GVWR. If you have any questions regarding safe loading of your VICTORY motorcycle, please consult an authorized VICTORY dealer.

## Loading Examples

<b>EXAMPLE 4:</b> <b>KINGPIN</b> <b>with no accessories or cargo.</b>  <b>Gross Vehicle Weight Rating:</b> <b>1234 lbs (560 kg)</b>	Item	Weight
	Motorcycle with full capacity of all fluids	704 lbs (319 kg)
	Operator with recommended riding apparel	230 lbs (104 kg)
	Passenger with recommended riding apparel (passenger models)	165 lbs (75 kg)
	<b>Total Weight</b>	<b>1099 lbs (498 kg)</b>

<b>EXAMPLE 5:</b> <b>KINGPIN TOUR</b> <b>with cargo.</b>  <b>Gross Vehicle Weight Rating:</b> <b>1234 lbs (560 kg)</b>	Item	Weight
	Motorcycle with full capacity of all fluids	769 lbs (349 kg)
	Cargo (top box at capacity)	20 lbs (9 kg)
	Cargo (saddlebags at capacity)	14 lbs (6 kg)
	Operator with recommended riding apparel	230 lbs (104 kg)
	Passenger with recommended riding apparel (passenger models)	165 lbs (75 kg)
<b>Total Weight</b>	<b>1198 lbs (543 kg)</b>	

**NOTE:** The weight of any accessory items such as saddlebags and brackets, or individual items *in addition* to the cargo, must be added to the base weight of the motorcycle. NEVER exceed GVWR. If you have any questions regarding safe loading of your VICTORY motorcycle, please consult an authorized VICTORY dealer.



# SAFETY

## Carrying Cargo

Use the following guidelines when attaching cargo or accessories to the motorcycle. Where applicable, these guidelines also refer to the contents of any accessories.

- Keep cargo and accessory weight to a minimum, and keep items as close to the motorcycle as possible to minimize a change in the motorcycle's center of gravity. Changing the center of gravity can cause loss of stability and handling and result in loss of control.
- Distribute weight evenly on both sides of the motorcycle. Maintain even weight distribution by checking accessories and cargo to make sure they're securely attached to the motorcycle before riding and whenever you take a break from riding. Uneven weight distribution, or accessories or cargo that shift suddenly while you're riding can make the motorcycle hard to handle and result in loss of control.
- Do not attach large or heavy cargo such as sleeping bags, duffel bags or tents to the handlebars, front fork area or front fender. Cargo or accessories placed in these areas can cause instability (due to improper weight distribution or aerodynamic changes) and can cause loss of control. Such items can also block air flow to the engine and cause overheating that can damage the engine.
- Do not exceed the maximum cargo weight limit of any accessory (see accessory instructions and labels), and do not attach cargo to an accessory not designed for that purpose, as these could result in an accessory failure that could cause loss of control.
- Except for highway footrests, do not attach anything else to the highway bar.

## Saddlebags / Top Box

When operating a motorcycle with original equipment or accessory saddlebags:

- Never ride at speeds exceeding 80 mph (129 km/h). Depending on load and weather conditions, the maximum safe operating speed may be less than 80 mph (129 km/h). Saddlebags, combined with the lifting or buffeting effects of wind, can make the motorcycle unstable and cause loss of control.
- Distribute weight evenly in each of the saddlebags.
- Do not exceed the maximum cargo weight limit of the saddlebags.
  - Accessory leather saddlebags, semi-hard saddlebags, or hard saddlebags = 7 lbs. (3.2 kg) each
  - Top Box weight capacity (Kingpin Tour) = 20 lbs. (9.0 kg)
- Do not exceed the motorcycle's gross vehicle weight rating. Exceeding the weight rating can reduce stability and handling and cause loss of control.

# **SAFETY**

## **Modifications**

Modifying the motorcycle by removing any equipment or by adding equipment not approved by VICTORY may void your warranty. Such modifications may make the motorcycle unsafe to ride and could result in severe injury to operator or passengers, as well as damage to the motorcycle. Some modifications may also be illegal in some states. If in doubt, contact your authorized VICTORY Dealer.

## **Parking the Motorcycle**

When leaving the motorcycle unattended, turn the engine off and remove the ignition key. See page 79.

Park the motorcycle where people are not likely to touch the hot engine or exhaust system or place combustible materials in close proximity to these hot areas. Do not park near a flammable source such as a kerosene heater or an open flame, where hot components could ignite combustible materials.

Park the motorcycle on a firm, level surface. Sloped or soft surfaces may not support the motorcycle when it's parked, and it may tip over. If you must park on a slope or soft surface, follow the precautions outlined on page 79.

## Transporting the Motorcycle

If you must transport the motorcycle:

- Use a truck or trailer. Do not tow the motorcycle with another vehicle, as towing will impair the motorcycle's steering and handling, which can cause loss of control.
- Position and restrain the motorcycle so it remains upright on the truck or trailer, as gasoline may leak out of the fuel tank if the motorcycle leans to one side. Gasoline is a fire hazard and it can also damage the motorcycle's finish.
- Place the transmission in neutral.
- Do not restrain the motorcycle using the handlebars. Loosen the front turn signal mounts and slide them up to make room for the tiedown strap. Place tie-downs around the fork tubes above the lower triple clamp. Secure the rear of the motorcycle with tiedowns around the swingarm, being careful to avoid the brake line, exhaust, and drive belt. Reposition the turn signals after transportation.

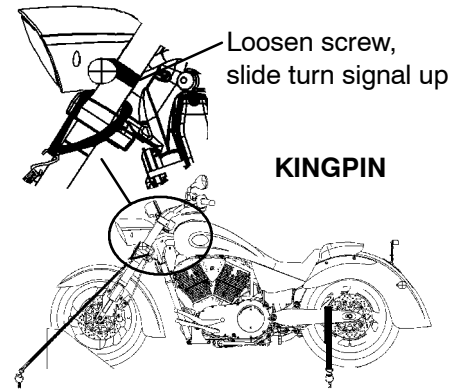

**VEGAS**

# SAFETY

## Accessory Selection and Installation

Because VICTORY cannot test and make specific recommendations concerning every accessory or combination of accessories sold, the operator is responsible for determining that the motorcycle can be safely operated with any accessories or additional weight. Use the following guidelines when choosing and installing accessories:

- Do not install accessories that impair the stability, handling or operation of the motorcycle. Before installing an accessory, be sure that it does not:
  - Reduce ground clearance when the motorcycle is either leaned or in a vertical position.
  - Limit suspension or steering travel or your ability to operate controls.
  - Displace you from your normal riding position.
  - Obscure lights or reflectors.
- Bulky or large accessories can cause instability (due to the lifting or buffeting effects of wind) and loss of control.
- Do not install electrical accessories that exceed the capacity of the motorcycle's electrical system. Never install higher wattage light bulbs than those supplied as original equipment. An electrical failure could result and cause hazardous loss of engine power or lights or damage to the electrical system.
- If you want to add a windshield, backrest or luggage rack, choose one designed and approved by VICTORY specifically for your model. Follow the instructions for proper installation and use. An improperly designed or installed windshield, backrest or luggage rack can reduce stability, causing loss of control.

## Gasoline and Exhaust

For complete fueling procedures, see page 70.

Gasoline is highly flammable and can be explosive in certain conditions. Observe the following precautions when you refuel or service the fuel system:

- Turn off the engine.
- Use a well-ventilated area.
- Open the fuel cap slowly.
- Do not spill gasoline on the engine or the exhaust system. Immediately wipe, or rinse with water, gasoline spilled on any part of the motorcycle or the surrounding area.
- Do not smoke while fueling.
- Do not fuel in an area where there are sparks or open flame.

Gasoline and gasoline vapors are poisonous and can cause severe injury. Do not swallow gasoline, inhale gasoline vapors, or spill gasoline on yourself or your clothes. If you swallow gasoline, inhale more than a few breaths of gasoline vapor, or get gasoline in your eyes, see a physician immediately. If you spill gasoline on your skin, wash it off immediately with soap and water. If you spill gasoline on your clothes, change your clothes immediately.

Exhaust gases contain carbon monoxide, a colorless, odorless gas that can cause unconsciousness or severe injury. Observe the following precautions to avoid the effects of exhaust gases:

- Do not inhale exhaust gases.
- Do not start or run the engine in an enclosed area.

# SAFETY

## Maintenance

Maintain the motorcycle according to the following requirements:

- Before each ride, complete a pre-operation check as outlined beginning on page 50. Operating the motorcycle without completing the pre-operation check can cause damage to the motorcycle or result in an accident.
- Perform periodic maintenance according to the intervals outlined in the Periodic Maintenance Interval tables beginning on page 82. Operating the motorcycle without performing periodic maintenance can damage the motorcycle or result in bodily injury.
- Maintain proper tire pressure and tread condition and proper wheel and tire balance. Inspect tires regularly and replace them if they're worn or damaged. Use only an approved replacement tire and see the *VICTORY Service Manual* or your authorized VICTORY Dealer for tire replacement. Operating the motorcycle with improper tire pressure or tread condition, or improper wheel or tire balance, can make the motorcycle hard to handle and cause loss of control.
- Check proper steering head bearing adjustment. Regularly inspect the rear shock absorber and the front forks. Check for fork oil or shock absorber fluid leaks. Operating the motorcycle with a loose, worn, or damaged steering system or front or rear suspension system can make the motorcycle hard to handle and cause loss of control. To repair steering or suspension system wear or damage, see the *VICTORY Service Manual* or contact your authorized VICTORY Dealer.

## Maintenance

- Keep the motorcycle clean. In addition to extending the service life and the original appearance of the motorcycle, a complete and thorough cleaning can reveal items in need of repair. For complete cleaning procedures, see page 144.
- Keep equipment required by federal, state, and local laws in place and in good working condition. Your license plate must be clean, clearly visible in all conditions, and installed in a position specified by law.
- Each fastener used in the motorcycle meets our quality specifications for strength, finish and type. When replacement fasteners are needed, use only genuine VICTORY parts, tightened to the proper torque. A fastener that does not meet original specifications could fail and result in damage to the motorcycle or injury to riders.

## Electromagnetic Interference

This vehicle complies with European directive 97/24/EC Chapter 8 requirements, which is equivalent to Canadian ICES-002.





# SAFETY

## Location of Safety and Vehicle Information Labels (All Models)

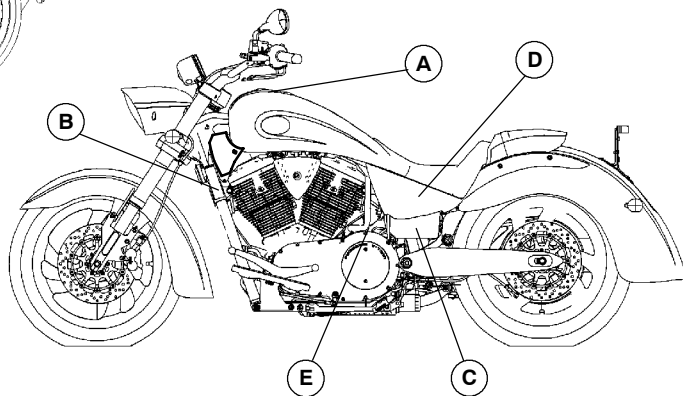
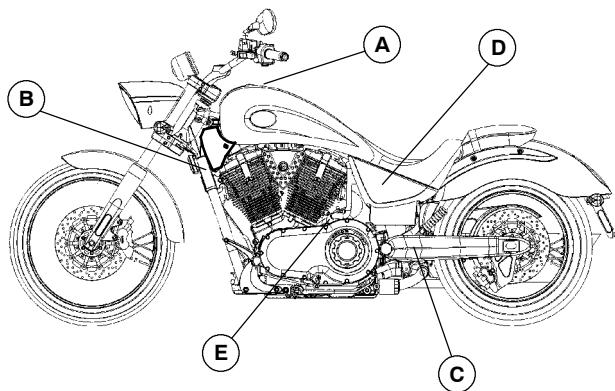

See page 25 for decal type and description.



## Location of Safety and Vehicle Information Labels (All Models)

 <b>WARNING</b>	 <b>AVERTISSEMENT</b>
<ul style="list-style-type: none"> <li>□ Read Owner's Manual and, during use, follow all safety precautions.</li> <li>□ Always wear an approved helmet, eye protection and protective clothing.</li> <li>□ If your Owner's Manual is missing, contact a Victory / Polaris dealer for a replacement.</li> </ul>	<ul style="list-style-type: none"> <li>□ Lire le Manuel d'utilisation et suivre toutes les consignes de sécurité durant l'utilisation.</li> <li>□ Toujours porter un casque de sécurité approuvé, des lunettes et des vêtements de protection.</li> <li>□ Si il n'y a pas de manuel du propriétaire, en demander un auprès d'un concessionnaire Victory/Polaris.</li> </ul>
UNLEADED FUEL RECOMMENDED	CARBURANT SANS PLOMB RECOMMANDÉ

### Location A (FUEL WARNING)

	<b>VEHICLE EMISSION CONTROL INFORMATION</b> <small>VECTRA MOTORCYCLE DIVISION MILWAUKEE, WI U.S.A. 53190-0000</small>		<b>INFORMATION SUR LE CONTRÔLE DES ÉMISSIONS DES</b> <small>VECTRA MOTORCYCLE DIVISION MILWAUKEE, WIS. U.S.A. 53190-0000</small>
<small>                 MODEL: DUNE/ACROBAT 1600cc                  LEGAL: JAKULI / TROUCLASHE                  ENGINE: 1600cc / 1600cc                  ENGINE TIMING: SPECIFICATIONS                  OIL: 10W/40                  IGNITION TIMING: PERMANENTLY FACTORY SET                  VALVE CLEARANCE: ADJUSTABLE TAPSET SPRING/ADJUSTING                  SPARK PLUG: BPR 1600-10                  AIR FILTER: OIL FREE                  FUEL INJECTION: GASOLINE ONLY / PUMP-OVERFLOW OR HOOPER                  (SEE OWNER'S MANUAL)             </small>	<small>                 CYLINDER: 1600cc / 1600cc                  PISTON: 1600cc / 1600cc                  TRANSMISSION: 1600cc / 1600cc                  REAR AXLE: 1600cc / 1600cc                  FRONT AXLE: 1600cc / 1600cc                  BRAKE: 1600cc / 1600cc                  LIGHTS: 1600cc / 1600cc                  HORN: 1600cc / 1600cc                  MIRRORS: 1600cc / 1600cc                  SAFETY: 1600cc / 1600cc                  INDEX: 1600cc / 1600cc             </small>		
<small>THIS VEHICLE CONFORMS TO US EPA REGULATIONS APPLICABLE TO 2007 MODEL YEAR NEW MOTORCYCLES.</small>		<small>CE VÉHICULE EST CONFORME AUX DISPOSITIONS RÉGLEMENTAIRES DE L'ÉMISSION DES GAZ ÉCHAPPÉMENT AUX MOTO-CYCLES NEUVEUX (2007).</small>	

### Location C (NOISE EMISSION)

VIN: XXXXXXXXXXXXXXXXX	TIRE INFORMATION	
COLD TIRE PRESSURES:	FRONT: XX psi (XXX kPa)	REAR: XX psi (XXX kPa)
UP TO 200 lbs (91kg) LOAD:	FRONT: XX psi (XXX kPa)	REAR: XX psi (XXX kPa)
UP TO MAXIMUM LOAD CAPACITY:	FRONT: XX psi (XXX kPa)	REAR: XX psi (XXX kPa)
MAXIMUM LOAD CAPACITY:	XXX lbs (XXX kg)	
TIRE BRAND/TYPE:	FRONT: XXXXXX XXX XXXXX XX	REAR: XXXXXX XXXX
TIRE SIZE:	FRONT: XXXX XXX XXX	REAR: XXX/XX XXX XXX
MINIMUM RECOMMENDED TIRE CENTER TREAD DEPTH:	FRONT/REAR: X.X mm (X/XX")	
TIRES REQUIRE TUBS READ OWNER'S MANUAL		

### Location D (TIRE INFORMATION)

(Under Left Side Cover)

Information varies by model

### Location E (ENGINE I.D.)

(on right rear crankcase half)

DATE MFD: XXXXXX			
MANUFACTURED BY: VICTORY MOTORCYCLE DIVISION, POLARIS INDUSTRIES INC.			
GVWR: XXXX LBS (XXX KG)			
VIN: _____			
*XXXXXXXXXXXXXXXXXXXX*			
XXXX MOTORCYCLE			
GAWR	TIRE	RIM	COLD INFLATION PRESSURE
F: XXXX LBS (XXX KG)	XXX/XX XXX XXX	XX" x X"	XX PSI (XXX KPA)
R: XXXX LBS (XXX KG)	XXX/XX XXX XXX	XX" x X.X"	XX PSI (XXX KPA)
THIS VEHICLE CONFORMS TO ALL APPLICABLE FEDERAL MOTOR VEHICLE SAFETY STANDARDS IN EFFECT ON THE DATE OF MANUFACTURE SHOWN ABOVE.			

### Location B (MANUFACTURING INFORMATION)

Information varies by model

# SAFETY

## Location of Safety and Vehicle Information Labels (All Models)

See page 27 for decal type and description.

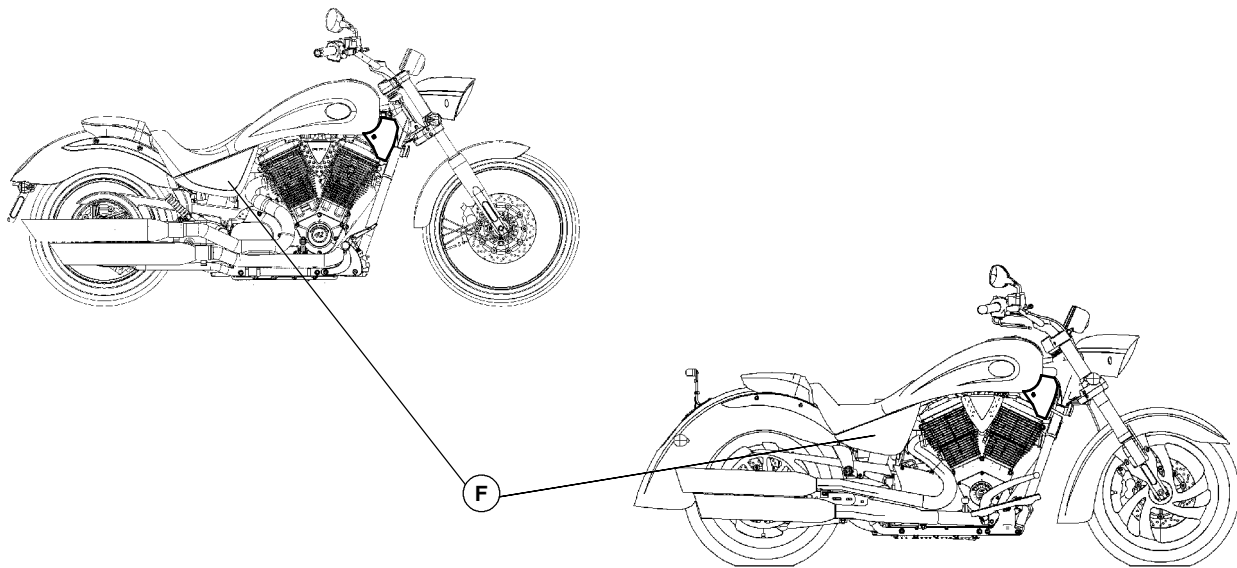

## Location of Safety and Vehicle Information Labels (All Models)

ACCESSORY RELAY	FUEL PUMP RELAY	ENGINE RELAY	PRIMARY LIGHTS RELAY
SEC. LIGHTS 15A	PRI. LIGHTS 15A	ENGINE 15A	SECONDARY LIGHTS RELAY  7174385
ACCESSORY 15A	IGNITION 15A	FUEL PUMP 10A	

### Location F

#### FUSE and RELAY LOCATION

(Under right side cover, on side of fuse box cover)

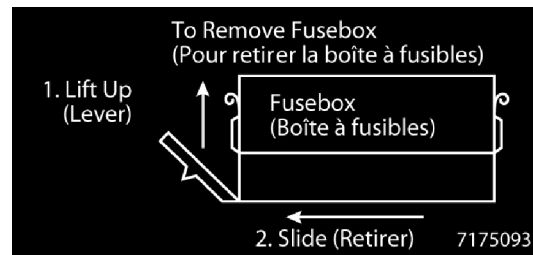

#### FUSE BOX REMOVAL (on base of fuse box)

# SAFETY

## Location of Safety and Vehicle Information Labels (All Models)

See page 29 for decal type and description.

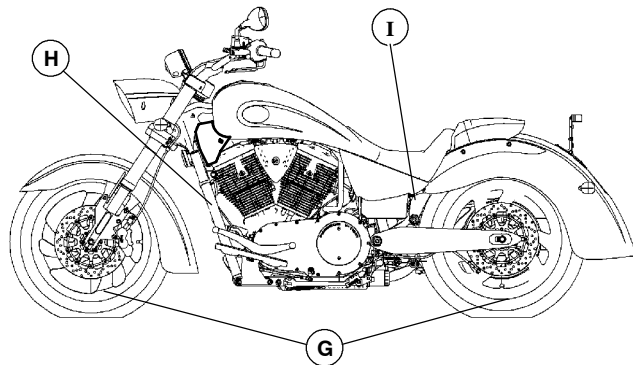
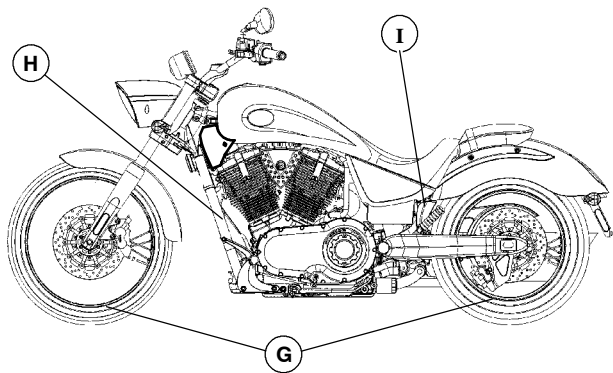



# **SAFETY**

## **Reporting Safety Defects**

If you believe that your vehicle has a defect that could result in a crash or cause injury or death, you should immediately inform the National Highway Traffic Safety Administration (NHTSA) in addition to notifying Polaris Industries in writing.

If NHTSA receives similar complaints, it may open an investigation, and if it finds that a safety defect exists in a group of vehicles, it may order a recall and remedy campaign. However, NHTSA cannot become involved in individual problems between you, your dealer or Polaris Industries.

To contact NHTSA, or obtain other information about motor vehicle safety, you may either call the Vehicle Safety Hotline toll-free at 1-888-327-4236 (TTY 1-800-424-9153), visit the NHTSA website at [www.safercar.gov](http://www.safercar.gov), or write to:

ADMINISTRATOR

NHTSA

US Department of Transportation

400 7th Street Southwest

Washington, DC 20590

# COMPONENT IDENTIFICATION

## Handlebar Area - VEGAS Models

1. Speedometer
2. Front Brake Fluid Reservoir
3. Right Mirror
4. Throttle Control Grip
5. Front Brake Lever
6. Right Handlebar Switch
7. Indicator Lamps
8. Fuel Cap
9. Left Handlebar Switch
10. Clutch Lever
11. Left Mirror

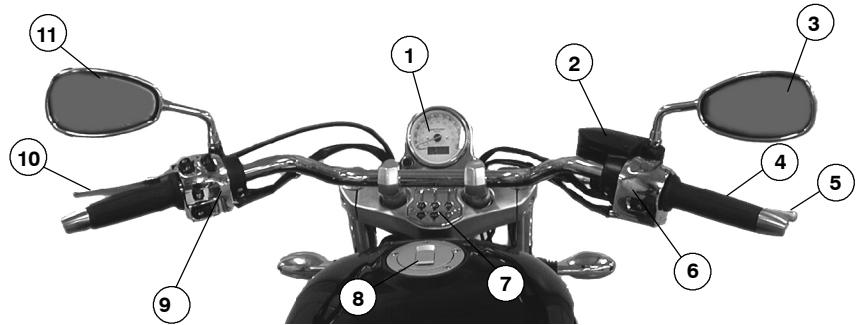



# COMPONENT IDENTIFICATION

## Left Side - VEGAS Models

1. Front Fork
2. Front Turn Signal
3. Headlamp
4. Air Filter
5. Spark Plug (2)
6. Ignition Switch
7. Left Side Cover
8. Battery (under side cover)
9. Taillight
10. Rear Turn Signal
11. Rear Axle Adjuster (1 each side)
12. Rear Brake Caliper
13. Passenger's Foot Rest (passenger models)
14. Evaporative Canister (California Models)
15. Engine Oil Filter
16. Engine Oil Drain Plug (under engine)
17. Sidestand
18. Operator's Foot Rest
19. Gear Shift Lever
20. Horn
21. Front Brake Caliper

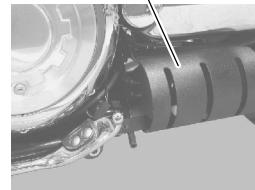
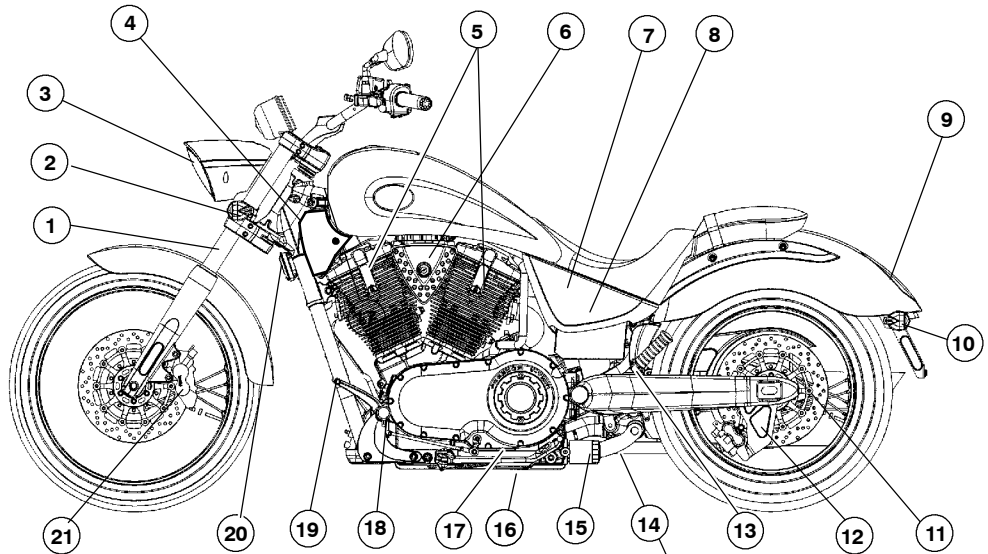

# COMPONENT IDENTIFICATION

## Right Side - VEGAS Models

1. Drive Belt (under guard)
2. Passenger Seat  
(passenger models)
3. Seat Strap
4. Operator's Seat
5. Side Cover
6. Rear Shock Absorber  
(access through RH side cover)
7. Front Turn Signal
8. Front Fork
9. Rear Brake Pedal
10. Operator Foot Rest
11. Engine Oil Fill Cap/Dipstick
12. Rear Brake Fluid Reservoir  
(under side cover)
13. Drive Sprocket (under cover)
14. Fuses (under side cover)
15. Diagnostic Connector
16. Passenger Foot Rest (passenger models)
17. Exhaust Mufflers

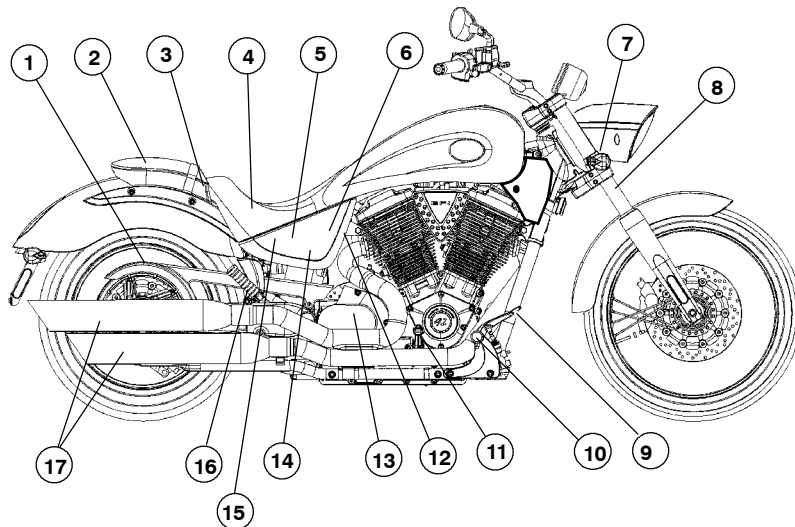

# COMPONENT IDENTIFICATION

## Handlebar Area - KINGPIN Models

1. Indicator Lamps
2. Front Brake Fluid Reservoir
3. Right Handlebar Switch
4. Right Mirror
5. Throttle Control Grip
6. Throttle Cables
7. Fuel Cap
8. Left Mirror
9. Left Handlebar Switch
10. Clutch Lever

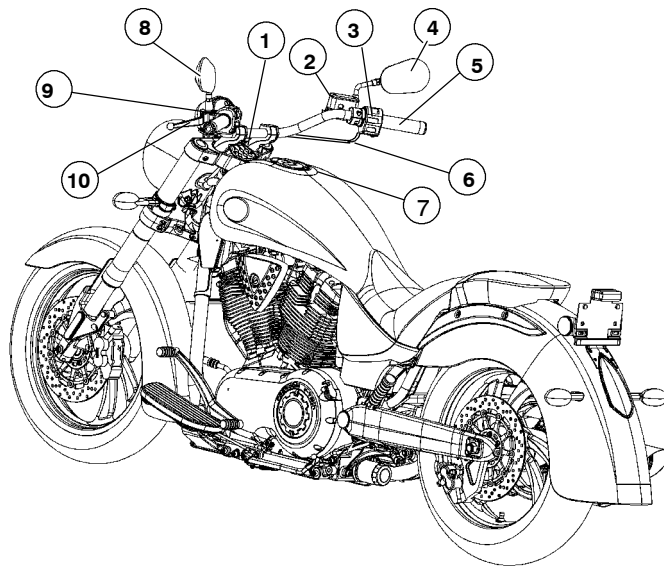

# COMPONENT IDENTIFICATION

## Left Side - KINGPIN Models

1. Front Fork
2. Front Turn Signal
3. Headlamp
4. Speedometer
5. Air Filter
6. Spark Plug (2)
7. Ignition Switch
8. Left Side Cover
9. Battery (under side cover)
10. Taillight
11. Rear Turn Signal
12. Rear Axle Adjuster (1 each side)
13. Rear Brake Caliper
14. Passenger's Foot Rest  
(passenger models)
15. Evaporative Canister (California Models)
16. Oil Filter
17. Oil Drain Plug (on bottom of crankcase)
18. Sidestand
19. Operator's Foot Rest
20. Gear Shift Lever
21. Front Brake Caliper

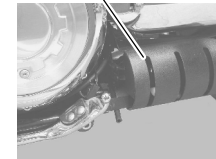
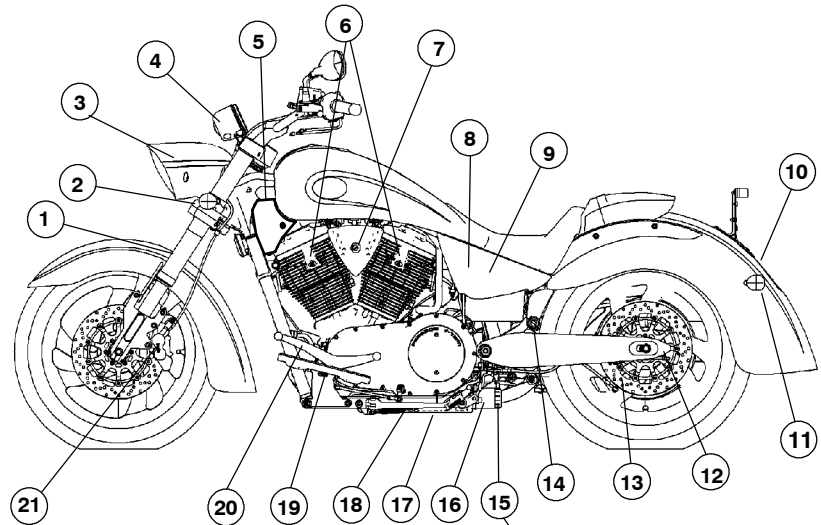

# COMPONENT IDENTIFICATION

## Right Side - KINGPIN Models

1. Passenger's Seat (passenger models)
2. Seat Strap
3. Operator's Seat
4. Rear Shock Absorber  
(access through RH side cover)
5. Side Cover
6. Engine Oil Fill Cap/Dipstick
7. Front Brake Lever
8. Front Turn Signal
9. Horn
10. Front Fork
11. Rear Brake Pedal
12. Operator's Foot Rest
13. Rear Brake Fluid Reservoir
14. Drive Sprocket (under cover)
15. Fuses (under side cover)
16. Diagnostic Connector
17. Passenger Foot Rest (passenger models)
18. Drive Belt (under guard)
19. Exhaust Mufflers

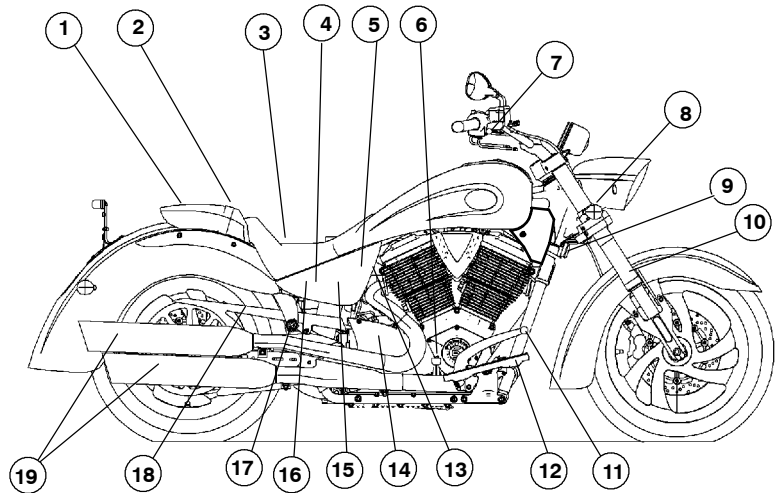

# COMPONENT IDENTIFICATION

## Vehicle Identification Number

The vehicle identification number (VIN) is stamped into the front of the steering head and also appears on the certification label. You will need the vehicle identification number to title, register, license or insure the motorcycle, or to order replacement parts.

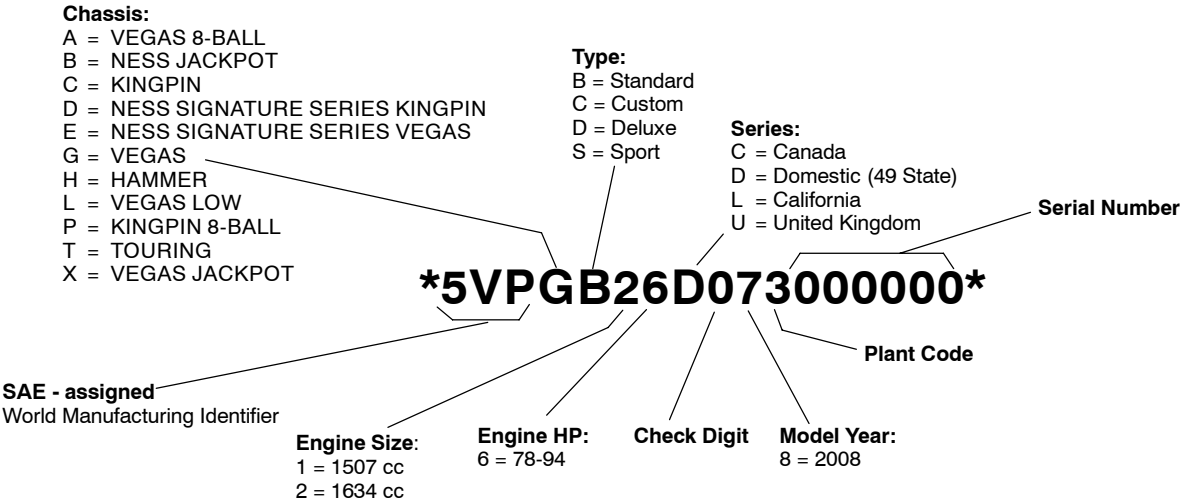

# COMPONENT IDENTIFICATION

## Engine Identification Number

The engine identification number is a combination of the engine model and serial numbers. The first 8 digits are the engine model number and the last 5 digits are the serial number.

The engine serial number is stamped into the rear upper portion of the right crankcase behind the rear cylinder. You may need the engine identification number to title, register, license or insure the motorcycle, or to order replacement parts.

## Ignition Key Number

The ignition key identification number is stamped into the shaft of each key.

With the ignition key number and proof of ownership, an authorized VICTORY dealer can assist you in obtaining a replacement key.

### Notice

For easy reference, record all vehicle numbers in the space provided on page 169.

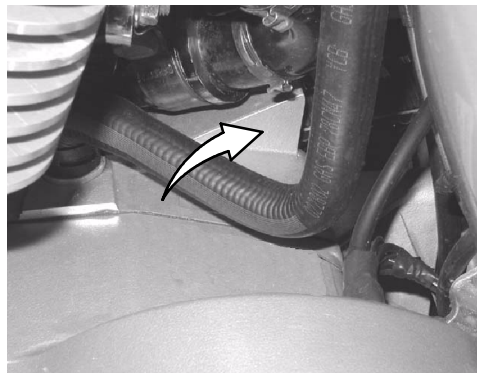

# INSTRUMENTS, FEATURES AND CONTROLS

## Ignition Key

The ignition key operates the ignition switch and parking lights.

## Ignition Switch

The ignition switch energizes the ignition, the lighting system, and all electrical switches and buttons.

### Off Position

In the OFF position, all electrical circuits are inactive and the ignition key can be removed. Turn the ignition switch to the OFF position and remove the ignition key when leaving the motorcycle unattended.

### On Position

In the ON position, all electrical circuits are energized and the ignition key cannot be removed. The headlamp, taillight, and instrument lights illuminate. With the engine stop/run switch set to the RUN position (see page 46) you can start the engine. You can also activate the emergency flashers, turn signals and all other electrical features.

## Caution

Before starting the engine, read the instructions for starting the engine beginning on page 71.

## Park Position (P)

In the PARK position, the taillight, indicator lights, and license plate light illuminate, the emergency flashers can be activated, and the ignition key can be removed. You must push the ignition key into the switch while selecting the Park position.

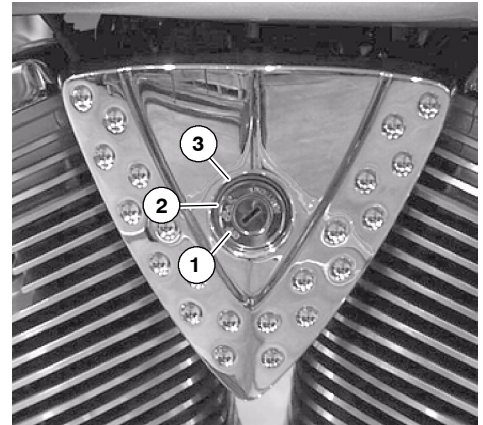

- 1. Off
- 2. On
- 3. P (Park)



# INSTRUMENTS, FEATURES AND CONTROLS

## Instrument Cluster

The instrument cluster includes the speedometer, the tachometer (accessory) and the multi-function display.

1. Speedometer
2. Odometer / Trip Odometer
3. Odometer & Trip Odometer Toggle / Trip Odometer Reset

## Speedometer

The speedometer reports current motorcycle speed in miles per hour (mph) or kilometers per hour (kph), Canada.

## Odometer

The odometer display shows total miles traveled in the window on the lower portion of the speedometer.

## Trip Odometer

A trip odometer is included on the speedometer. The trip odometer shows total miles traveled since the trip odometer was reset. You can use the trip odometer to calculate your miles per gallon and estimate the number of miles you can travel on a tank of fuel.

To toggle the display between Odometer and TRIP Odometer, the ignition switch must be in the ON position. Press the reset button (3). The display changes to “TRIP”.

To reset the trip odometer, the ignition switch must be in the ON position with the display in trip odometer mode. Press and hold the reset button (3) until the TRIP odometer display resets to zero.

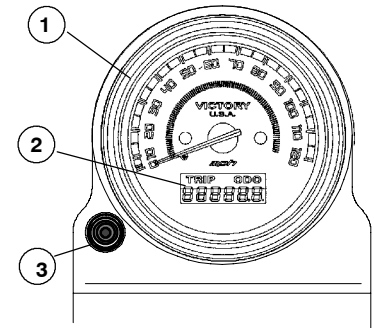

# INSTRUMENTS, FEATURES AND CONTROLS

## Tachometer (Accessory)

Some models are equipped with a tachometer (1). An accessory tachometer kit can also be purchased as an accessory through your VICTORY dealer. The tachometer reports current engine speed in revolutions per minute (RPM). A red line on the gauge indicates maximum safe engine RPM. With tachometer installed, the trip odometer reset button (2) is located on the instrument mounting plate. See page 40.

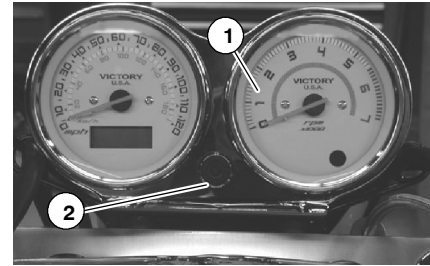

## **!** WARNING

**Do not operate the engine over 5600 RPM. Excessive RPM could cause engine damage or failure that could result in you losing control of the motorcycle.**

---

## Overdrive Indicator Lamp

The overdrive lamp (3) illuminates when O/D (6th gear) is selected (tachometer-equipped 100/6 engine only).



# INSTRUMENTS, FEATURES AND CONTROLS

## Indicator Lights

### Neutral Indicator (1)

**N** The neutral indicator illuminates when the transmission is in neutral, and the ignition key is ON.

### Headlamp High Beam Indicator (2)

 The headlamp high beam indicator illuminates when the headlamp switch is set to high beam (see page 44).

### Check Engine Indicator (3)

**ENG** The check engine indicator will illuminate any time the ignition switch is in the ON position and the engine control module sensors report abnormal sensor or engine operation. The check engine indicator will continue to illuminate as long as the fault condition exists. It also illuminates momentarily when the ignition switch is in the ON position and the engine is not running. This demonstrates that the indicator is functioning properly.

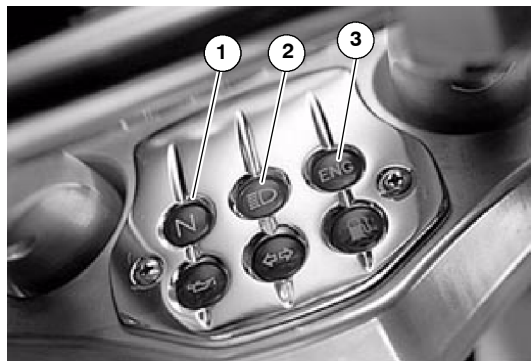

## Caution

If the check engine indicator illuminates while the engine is running, a serious engine problem may exist. Contact an authorized VICTORY dealer as soon as possible.

# INSTRUMENTS, FEATURES AND CONTROLS

## Indicator Lights

### Low Oil Pressure Indicator (4)



The low oil pressure indicator illuminates when engine oil pressure drops below safe operating pressure. If this indicator illuminates while the engine is running, turn the engine off immediately and check the oil level. Add oil if necessary. If the oil level is correct and the indicator remains illuminated after the engine is restarted, turn the engine off immediately.

The low oil pressure indicator also illuminates when the ignition switch is in the ON position and the engine is not running. This demonstrates that the indicator is functioning properly.

### Turn Signal Indicator (5)



The turn signal indicator flashes when the left, right, or both turn signals (hazard) are active.

If a turn signal bulb has failed, or if there is a short circuit in the turn signal system, the turn signal indicator flashes at more than twice the normal rate.

### Low Fuel Indicator (6)



The low fuel indicator illuminates when approximately 0.8 gallons (3.0 liters) of fuel remains in the fuel tank.

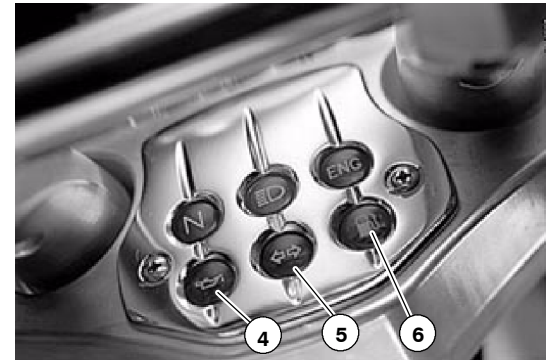

# INSTRUMENTS, FEATURES AND CONTROLS

## Left Handlebar Controls

### Emergency Flasher Switch



The emergency flasher switch activates and cancels the emergency flashers. When the emergency flashers are active, all of the turn signals flash. Press the top of the switch to activate the emergency flashers. Press the bottom of the switch to cancel the flashers.

### Headlamp High/Low Beam Switch



The headlamp high/low beam switch toggles the headlamp between high beam, low beam, and momentary passing beam. To activate the high beam, press the upper portion of the switch; to activate the low beam, press the lower portion of the switch. To activate the momentary passing beam, press and hold the lower portion of the switch.



### Horn Button



To sound the horn, press the horn button.

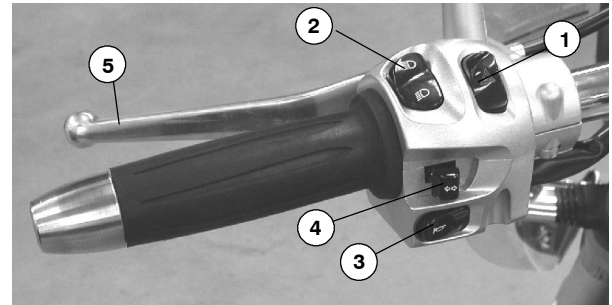

1. Emergency Flasher Switch
2. Headlamp High/Low Beam Switch
3. Horn Button
4. Turn Signal Switch
5. Clutch Lever

# INSTRUMENTS, FEATURES AND CONTROLS

## Left Handlebar Controls

### Turn Signal Switch Operation

⇐ ⇨ With the ignition key in the ON or PARK position, the turn signal switch activates the turn signals. Push the switch to the left to activate the left turn signals, and to the right to activate the right turn signals. To manually cancel either turn signal, push the switch in toward the housing when in the centered position. If activated below 15 mph\*, the turn signals cancel automatically shortly after the vehicle speed reaches 15 mph (24.1 kph). If a signal is activated with vehicle speed above 15 mph, cancellation will occur based on distance traveled. NOTE: If a signal is activated at speeds above 15 mph and vehicle speed drops below 15 mph, cancellation will occur shortly after speed again reaches 15 mph. (\*The 15mph speed is approximate)

### Turn Signal Switch - Momentary Feature

When passing a vehicle or when changing lanes, the operator has the option of using the momentary feature built in to the turn signal auto-cancel system. Push and hold the turn signal switch in the direction you wish to turn. Hold the switch through at least one complete flash cycle (at least 1 second). This activates the momentary feature, and the signal will cancel upon release of the switch.

### Clutch Lever

To disengage the clutch, pull the lever toward the handlebar. To engage the clutch, gradually release the lever. For smooth clutch operation, pull the lever quickly and release it gradually.

**Notice** The motorcycle is equipped with a clutch interlock switch that prevents the engine from starting when the transmission is in gear and the clutch is engaged (see page 71).

# INSTRUMENTS, FEATURES AND CONTROLS

## Right Handlebar Controls

### Engine Stop/Run Switch



The engine stop/run switch completes or interrupts the ignition, starter, and fuel pump circuits. To complete the circuits, allowing the engine to start and run, press the lower portion of the engine stop/run switch (RUN position).



To interrupt the circuits, press the upper portion of the switch (STOP position). The engine should not start or run when the switch is in the STOP position.

Use the engine stop/run switch to turn the engine off under either normal or emergency conditions.

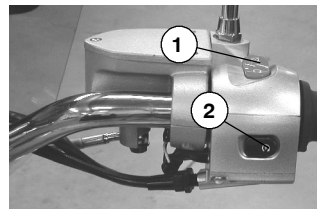

### Starter Button



The starter button works only when the engine stop/run switch is in the RUN position and the transmission is in neutral or the clutch is disengaged. To engage the engine starter motor, press the right side of the starter button. For complete engine starting procedures, see Starting the Engine, page 71.

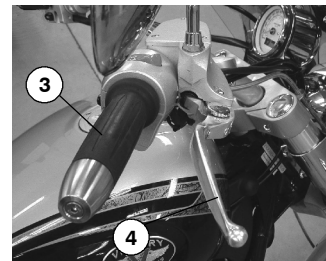

### Throttle Control Grip

The throttle control grip controls the engine speed. To increase engine speed, twist the throttle control grip toward you. To decrease engine speed, twist the grip away from you. When you release the grip, it returns to the idle speed position.

### Front Brake Lever

The front brake lever is located on the far side of the right handlebar grip. To apply the front brake, pull the front brake lever toward the handlebar. For braking procedures in various riding conditions, see Braking (page 77).

1. Engine Stop/Run Switch
2. Starter Button
3. Throttle Control Grip
4. Brake Lever

# INSTRUMENTS, FEATURES AND CONTROLS

## Gear Shift Pedal

The gear shift pedal (1) is located on the left side of the motorcycle. To shift to a lower gear, press down on the gear shift pedal. To shift to a higher gear, lift up on the gear shift pedal.

For proper gear shifting procedure, see Shifting Gears, pages 73 and 74.

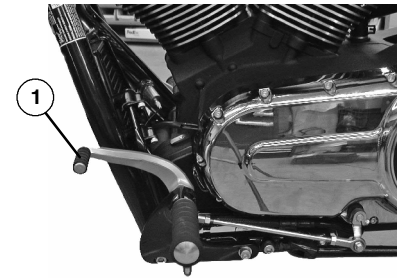
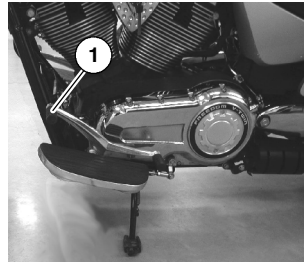

## Rear Brake Pedal

The rear brake pedal (2) is on the right side of the motorcycle. To engage the rear brake, press down on the rear brake pedal.

For braking procedures in various riding conditions, see Braking, page 77.

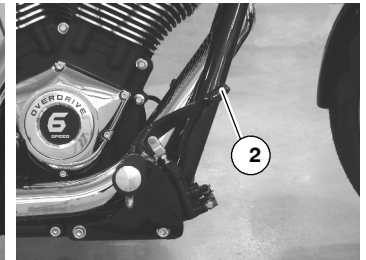
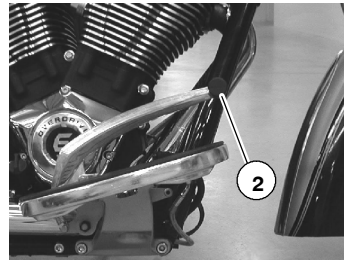



# INSTRUMENTS, FEATURES AND CONTROLS

## Fuel Cap

The fuel cap must be opened and closed with the ignition key. Lift the key slot cover (1) on the cap and insert key. Turn clockwise while pushing down lightly to release latch and open the cap. To close the fuel cap, turn key clockwise and press down on the cap. Turn key counterclockwise while maintaining pressure on the cap. Remove key and close the key slot cover.

For fueling procedure, see Fueling and Fill Height, page 70.

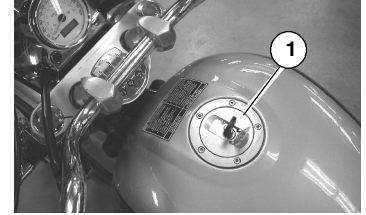

## Side Covers

Your motorcycle is equipped with two removable side covers. Remove the left side cover to access the battery. Remove the right side cover to access the fuses and the rear brake fluid reservoir.

To remove either side cover, pull the rear corner of the side cover out slightly until tab (1) is disengaged. Pull lower edge (2) out and then front edge (3) to disengage remaining tabs and remove cover. Be sure rubber grommets are in place before reversing the above procedure to install the side covers. A solution of dish soap and water can be used as a lubricant if required for installation.

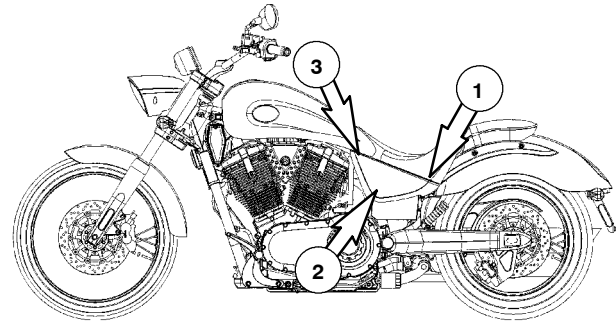

# INSTRUMENTS, FEATURES AND CONTROLS

## Sidestand

The sidestand (1) is located on the left side of the motorcycle.

To extend the sidestand, swing it out from the end until it is fully extended. Lean the motorcycle toward the sidestand until the sidestand firmly supports the motorcycle.

To retract the sidestand, lean the motorcycle away from the sidestand until the motorcycle is fully upright. Swing the sidestand back into its fully retracted position.

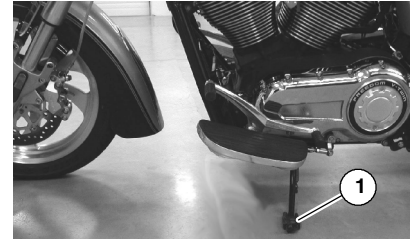

### **WARNING**

**Correctly retract the sidestand before operating the motorcycle. An improperly retracted sidestand could come into contact with the ground and cause loss of control.**

---

## PRE-OPERATION CHECK

To keep your VICTORY motorcycle in good operating condition, always perform the checks described in this section before each ride. This is especially important before making a long trip or when removing the motorcycle from storage. You must be familiar with the VICTORY motorcycle instruments and controls to make these checks. You can find additional service information in the maintenance section of this manual, in the *VICTORY Service Manual* or from an authorized VICTORY dealer.

During the pre-operation check you might use products that are potentially hazardous, such as oil or brake fluid. When using any of these products, follow the instructions and warnings on the product packaging.

### **WARNING**

**Failure to perform these checks before operating the motorcycle may result in serious injury or damage. Adjust components designed for normal wear adjustment, and repair or replace worn or damaged components as needed.**

---

# PRE-OPERATION CHECK

## Check Electrical Equipment

To perform a pre-operation check on the electrical equipment, set the ignition switch to the ON position. Set the ignition switch to the OFF position after completing the electrical equipment portion of the pre-operation check.

## Indicator Lights

The low oil pressure indicator should illuminate until the engine is started. If the transmission is in neutral, the neutral indicator should remain illuminated.

## Headlamp

Check the headlamp to see that it is on. Set the headlamp switch to the high beam position. The headlamp brightness should increase and the headlamp high beam indicator light should illuminate.

## Taillight / Brake Light

With the ignition switch in the ON position, the taillight and the license plate light should illuminate. Apply slight pressure to the front brake lever; taillight brightness should increase. Apply slight pressure to the rear brake pedal; taillight brightness should increase.

# PRE-OPERATION CHECK

## Check Electrical Equipment

### Turn Signals

Move the turn signal switch to the left. The front and rear left turn signals and the turn signal indicator light on the panel should flash. Push the switch button IN to cancel the turn signal. The turn signals and turn signal indicator should stop flashing. Repeat the procedure for the right turn signals.

### Emergency Flashers

Press the top of the switch to activate the emergency flashers. All four turn signals and the turn signal indicator light on the panel should flash. Press the bottom of the switch to cancel the flashers. The turn signals and turn signal indicator should stop flashing.

### Horn

Press the horn button. The horn should sound loudly.

### Engine Stop/Run Switch

Be sure the engine stop/run switch stops the engine, or prevents the engine from starting when set to the STOP position.

#### **Notice**

If you regularly use this switch to shut off the engine, you're already checking its operation each time you use the motorcycle.

# PRE-OPERATION CHECK

## Check Engine Oil Level

A dipstick attached to the oil fill cap registers the engine oil level. We recommend the use of only VICTORY brand Semi-Synthetic 20W-40 Motor Oil or an equivalent oil designed for use with wet clutches (such as those with a JASO MA rating).

1. With the transmission in neutral, start and run the engine for several minutes.
2. Shut the engine off and wait for 3-5 minutes.
3. Straddle the motorcycle on level ground and bring it to a vertical position. Remove the oil fill cap/dipstick (1) and wipe the dipstick clean. Reinstall the dipstick and turn the cap clockwise until it seats.
4. Remove the dipstick again and read the oil level.
5. If necessary, add or remove oil to bring the level into the area on the dipstick above the ADD mark and below the FULL mark. Repeat step 1 and step 2 each time you adjust the oil level.

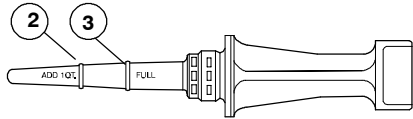
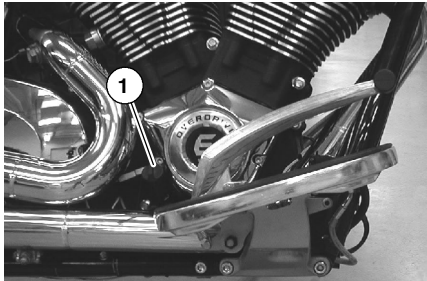

1. Oil Fill Cap/Dipstick
2. ADD Mark
3. FULL Mark

### **WARNING**

**Do not operate the motorcycle with the oil level above the FULL mark or below the ADD mark. Operating the engine with too much or too little oil can cause serious engine damage or engine seizure, resulting in loss of control.**

# PRE-OPERATION CHECK

## Check Fuel Components

### Fuel Level

1. Straddle the motorcycle on level ground and bring it to a vertical position.
2. Turn the ignition switch to the ON position and watch the fuel indicator light on the panel. **NOTE:** The light will stay on if less than .8 gallons (3.08 liters) remains in the tank after starting the engine.
3. Check the fuel level.
4. Estimate your next fuel stop and plan accordingly to avoid running out of fuel.

### Fuel Hose, Rail and Connections

Inspect the fuel hoses for cracks or damage. Inspect the hose connection at the fuel tank and at the fuel rail for dampness or stains from leaking or dried fuel.

### Evaporative Emission Control System (California models)

Visually inspect all evaporative emission control system hoses and connections. Make sure all connections are tight. Inspect the evaporative canister to make sure it has not been damaged. The canister is located on the left side of the motorcycle behind the side stand.

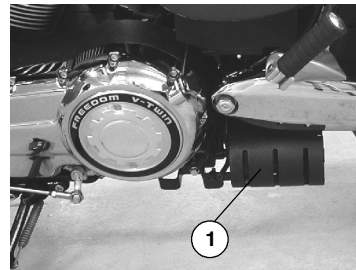

# PRE-OPERATION CHECK

## Check Tires

### Tire Pressure

Normal riding warms the tires and increases the tire air pressure. For an accurate reading, check the tire pressure before you ride. Adjust tire pressure as required for the total weight of your intended load. Refer to the tire pressure table on page 127, or to the decal on the motorcycle.

### Tire Condition

Inspect the tire sidewalls, road contact surface, and tread base for cuts, punctures, and cracking. Replace damaged tires immediately (see the *VICTORY Service Manual* or an authorized VICTORY dealer).

### Tire Tread Depth

Raised areas at the base of the tread, known as wear bars, act as easily visible tread depth indicators. See page 128. When the road contact surface has worn to the top of the wear bars, replace the tire.



# PRE-OPERATION CHECK

## Check Brakes

### Front Brake Lever Movement

Squeeze the front brake lever toward the handlebar and release it. It should move freely and smoothly and should return to its rest position quickly when released. You should feel a firm resistance in the lever within the first 3/4-inch (19 mm) of lever travel.

On some models, lever reach (distance to the hand grip) is adjustable. To adjust, pull and hold the lever away from the grip.

- To increase reach distance, turn the adjuster to align a lower number to the indicator mark on the lever.
- To decrease reach distance, turn the adjuster to align a higher number to the indicator mark on the lever.

On all other models, if the brake lever travels too far before beginning to engage the brake, see the *VICTORY Service Manual*, or contact an authorized VICTORY dealer for service.

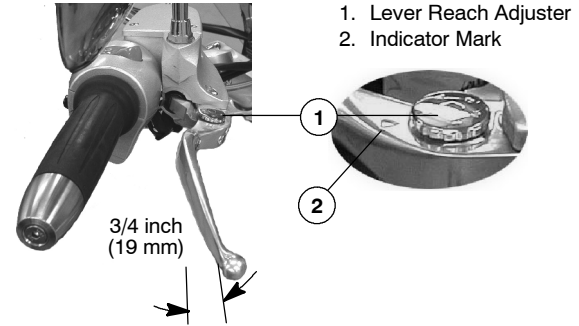

# PRE-OPERATION CHECK

## Check Brakes

### Front Brake Fluid Level

1. Position the motorcycle on level ground with the front wheel straight forward. Do not use the side stand. Position the handlebars so that the brake fluid reservoir is level.
2. View the brake fluid through the sight glass. The fluid should be clear and at a level in or above the sight glass. Add brake fluid if necessary (see page 119).

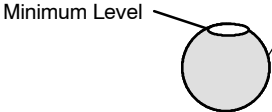
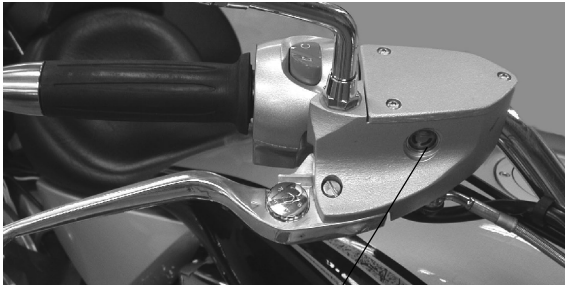

# PRE-OPERATION CHECK

## Check Brakes

### Rear Brake Pedal Adjustment

Press and release the rear brake pedal. It should move freely and smoothly and should return to its rest position quickly when you release it. You should feel a firm resistance in the pedal within the first 3/8 inch (8 mm) of pedal travel.

If the brake pedal travels too far before beginning to engage the brake, see the *VICTORY Service Manual*, or contact an authorized VICTORY dealer for service.

The brake pedal should be adjusted so that in the relaxed position, with the master cylinder piston positioned against internal stop, there is a 2-5 mm gap between the brake pedal stop and the foot peg mount. Make brake pedal adjustments as necessary. See page 121.

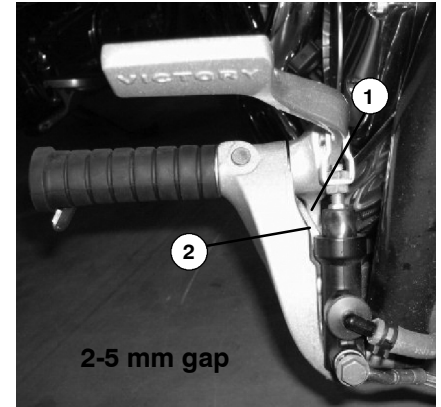

1. Brake pedal stop
2. Footpeg mount

# PRE-OPERATION CHECK

## Check Brakes

### Rear Brake Fluid Level

1. To check the rear brake fluid level, remove the right side cover. Straddle the motorcycle and bring it to a vertical position.
2. View the brake fluid through the reservoir. The fluid should be clear and at a level between minimum (MIN) and maximum (MAX) marks on the side of the reservoir. Add brake fluid if necessary (see page 123).

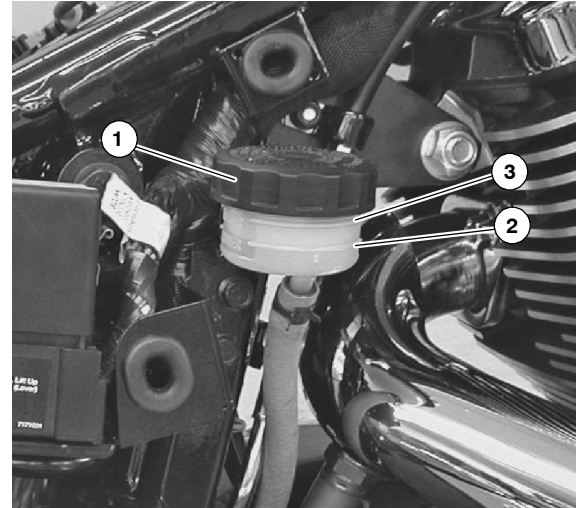

1. Rear brake fluid reservoir
2. MAX brake fluid level mark
3. MIN brake fluid level mark

# PRE-OPERATION CHECK

## Check Brakes

### Hoses and Connections

Inspect all brake hoses and connections for dampness or stains from leaking or dried fluid. Tighten any leaking connections and replace components as necessary. Refer to the Victory Service Manual for torque values of fasteners or contact your Victory dealer.

### Brake Pads

Inspect front (1) and rear (2) brake pad thickness. Replace brake pads when wear lines (3) are no longer visible, or when pad thickness reaches 1.5 mm. See page 124.

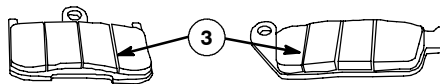
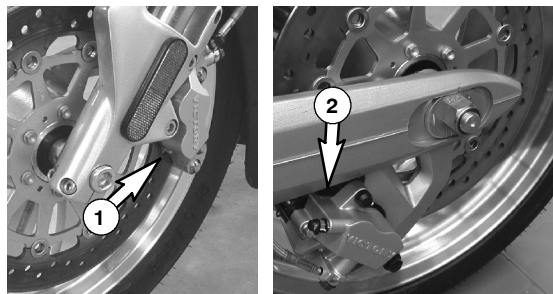

# PRE-OPERATION CHECK

## Check Throttle Control Grip and Cables

See your authorized VICTORY dealer for service if the throttle fails to operate smoothly, if the grip does not return to the rest position properly, or if throttle cable ends begin to fray.

- 1. Rotate the throttle control grip. It should rotate smoothly from its rest position to its completely open position and back again. It should return to its rest position quickly when released.
- 2. Throttle freeplay is the amount of throttle control grip movement from the rest position to the point of cable resistance. Freeplay should be 2-4 mm. Adjust throttle freeplay if necessary. See page 110.
- 3. Remove the right side access cover (1). Inspect throttle cables (2) for frayed ends.

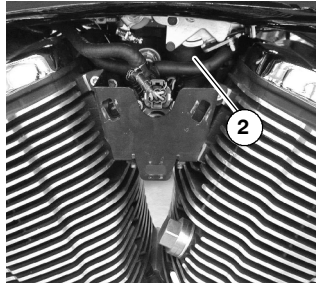
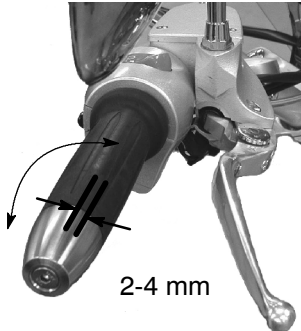

# PRE-OPERATION CHECK

## Check Clutch

### Mechanical Clutch

1. Squeeze the clutch lever toward the handlebar and release it. It should move freely and smoothly and should return to its rest position quickly when released.
2. Clutch lever freeplay is the amount of clutch lever movement from the rest position to the point of cable resistance. Freeplay (gap) should be .02-.06 inch (0.5-1.5 mm). Measure the gap between the clutch lever and the lever housing.
3. Adjust clutch lever freeplay if necessary (see page 112).

**NOTE:** The starter interlock switch is dependent on the clutch lever freeplay being set correctly to ensure activation of the clutch safety switch.

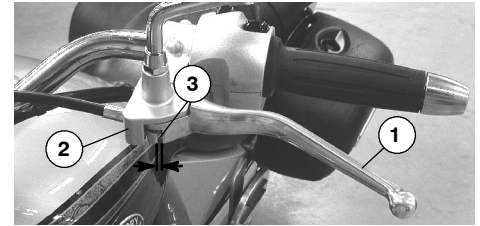

1. Clutch Lever
2. Lever Housing
3. Freeplay = .02-.06 inch (0.5-1.5 mm)

# PRE-OPERATION CHECK

## Check Clutch Hydraulic Clutch

Check the hydraulic clutch fluid level.

1. Position the motorcycle on level ground with the front wheel straight forward. Do not use the side stand. Position the handlebars so that the clutch fluid reservoir is level.
2. View the fluid level through the sight glass. The fluid should be clear and at a level in or above the sight glass. Add clutch fluid if necessary (see page 114).

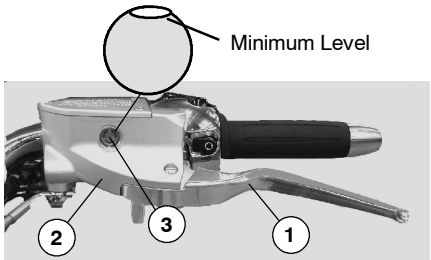

1. Clutch Lever
2. Lever Housing
3. Clutch Fluid Sight Glass



# PRE-OPERATION CHECK

## Check Front Suspension

1. To check the front suspension, straddle the motorcycle and bring it to a vertical position.
2. Apply the front brake and push down hard on the handlebars several times. The front suspension should operate smoothly and quietly.
3. Place the motorcycle on the sidestand and inspect the front forks. Make sure there is no fork oil present on the fork tube or around the fork seal.

## Check Steering

Straddle the motorcycle and bring it to a vertical position. Turn the handlebars from stop to stop. The action should be smooth but not loose or interfered with by wires, hoses or control cables.

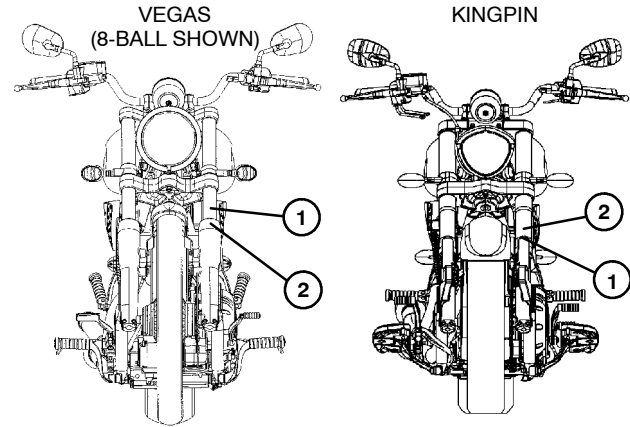

1. Front Fork Tube
2. Fork Seal

# PRE-OPERATION CHECK

## Check Rear Suspension

Proper rear suspension adjustment is essential for a safe and comfortable ride. Check the rear shock absorber movement and preload to ensure that the motorcycle has the correct amount of suspension travel and ground clearance (see page 100).

 **WARNING**

**Inadequate ground clearance could allow components to come into contact with the ground, causing loss of control.**

---

## Check Drive Belt

The drive belt should fit tightly. Check drive belt tension (see page 92).

Replace the drive belt if it is cracked or has broken teeth or frayed edges (consult your *VICTORY Service Manual* or an authorized VICTORY dealer).

# PRE-OPERATION CHECK

## Check Sidestand

Straddle the motorcycle and bring it to a vertical position. Move the sidestand (1) to its stored (up) position, then to its fully extended (down) position and back again. It should move smoothly and quietly. When the sidestand is in its stored position, the sidestand return spring should hold the sidestand tightly against the motorcycle.

Check the sidestand pivot bolt for looseness or wear. Tighten or replace if loose or worn.

Check the condition of the sidestand rubber pad (2), and make sure it's firmly attached to the sidestand. Check the wear indicator (3) on the leading edge of the sidestand rubber pad. Replace the pad if worn beyond the WEAR LIMIT line on the pad.

## Check Fasteners

Visually inspect the entire motorcycle chassis and engine for loose, damaged or missing fasteners. Tighten loose fasteners to the proper torque (see the specifications section of this manual or see the *VICTORY Service Manual*). Immediately replace stripped, damaged or broken fasteners with genuine VICTORY fasteners of equal size and strength immediately.

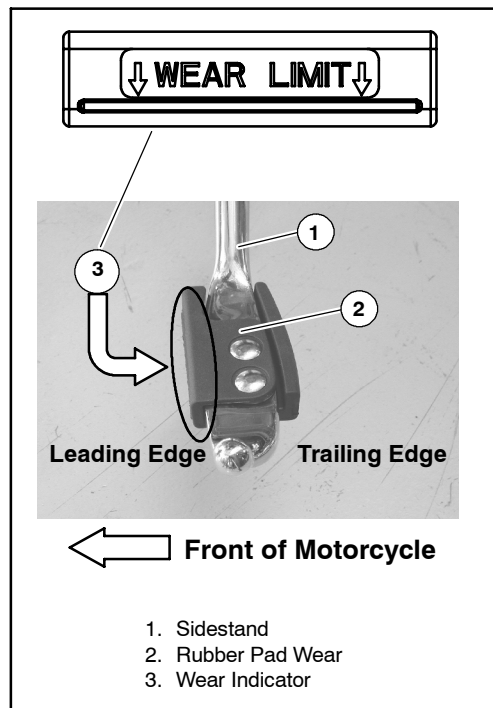

# OPERATION

The operation section describes how to operate your VICTORY motorcycle for best performance and longevity. Important areas covered include:

- Engine Break-in Period
- Fueling and Fill Height
- Starting the Engine
- Shifting Gears
- Accelerating
- Braking
- Stopping the Engine
- Parking

For safe operation and riding, see the safety section beginning on page 5.

# OPERATION

## Engine Break-in Period

During the first 500 miles (800 kilometers), critical engine parts require special wear-in procedures so they seat and mate properly. Read, understand and use the following rules for operating the motorcycle during the first 500 miles (800 kilometers) to ensure your engine's long-term performance and durability.

### Caution

Do not put unnecessary load on the engine during the first 500 miles (800 kilometers). Avoid prolonged full throttle operation or any condition that creates excessive engine heat.

---

#### **0-90 miles (0-145 kilometers)**

- Do not operate the motorcycle for extended periods of time at throttle positions above 1/3 throttle. Vary the engine speed of the motorcycle. Do not operate the motorcycle for extended periods of time at any one set throttle position.

#### **90-300 miles (145-483 kilometers)**

- Do not operate the motorcycle for extended periods of time at throttle positions above 1/2 throttle. Vary the engine speed of the motorcycle. Do not operate the motorcycle for extended periods of time at any one set throttle position.

## Engine Break-in Period

### 300-500 miles (483-800 kilometers)

- Do not operate the motorcycle for extended periods of time at throttle positions above 3/4 throttle.

### At 500 miles (800 kilometers)

- Perform initial maintenance as described in the Maintenance section of the *Owner's Manual*. This maintenance is one of the most important services your motorcycle requires and should be performed by an authorized VICTORY dealer. Initial maintenance service must include inspection / adjustments, tightening of fasteners, and engine oil and filter change. Performing this maintenance at the required mileage point helps ensure peak engine performance, minimal exhaust emissions, and maximum service life of the engine.

### Caution

If engine trouble should occur during the engine break-in period, consult the maintenance section of the *Owner's Manual*, the *VICTORY Service Manual*, or an authorized VICTORY dealer immediately.

---

# OPERATION

## Engine Break-in Period

### Fueling and Fill Height

Fuel the motorcycle with the sidestand down and on level ground. Use only the recommended fuel (see Fuel Specifications on page 168). Fill the fuel tank to a level just below the bottom of the fuel filler insert.

#### **WARNING**

- **Do not allow gasoline to come into contact with a hot engine or exhaust system. This could cause a fire. Immediately wipe, or rinse with water, gasoline spilled on any part of the motorcycle or the surrounding area.**
  - **Do not fill the fuel tank above the fuel filler insert. Overfilling the fuel tank may cause fuel to overflow when it expands.**
  - **Fuel may leak from an improperly seated fuel cap. Be sure the fuel cap properly seated and locked before starting the engine.**
- 

#### **Caution**

Fuel can damage painted surfaces and plastic parts. Wipe spilled fuel immediately from the motorcycle using a clean, dry, soft cloth.

---

## Engine Break-in Period

### Priming the Fuel System

**Notice**

If the motorcycle has run completely out of fuel, prime the system before starting the engine: Turn the ignition switch to the ON position. Toggle the engine stop/run switch from the STOP position to the RUN position. Allow the fuel pump to run until it stops (about 3 seconds). Toggle the switch to the STOP position and wait 3 seconds to allow the engine control module to reset. Repeat the RUN/STOP procedure 4-5 times, waiting 3 seconds between each toggle.

### Starting the Engine

The VICTORY motorcycle has a starter interlock system. The engine can be started only when the transmission is in neutral or when the transmission is in gear and the clutch is disengaged (clutch lever is pulled in).

Follow these steps to start the motorcycle:

1. Perform the Pre-Operation Check as outlined beginning on page 50. If you're carrying cargo, inspect the cargo restraints for tightness.
2. Insert the ignition key into the ignition switch and turn the switch to the ON position (see page 39).
3. Mount the motorcycle and bring it to an upright position. Engage the front brake and place the sidestand in the stored (up) position. If the neutral indicator is not illuminated, shift the transmission to neutral (see Shifting Gears, page 73).



# OPERATION

## Engine Break-in Period

### Starting the Engine

4. Set the engine stop/run switch to the RUN position. You should hear the fuel pump run momentarily as it pressurizes the fuel system. **NOTE:** If the motorcycle was run completely out of fuel, prime the system as instructed on page 71.
5. Leaving the throttle closed, press and hold the starter button until the engine starts. If the engine does not start within a few seconds after you press the starter button, release the button and wait several seconds. Then press and hold the starter button again. Hold the starter button for as short a time as possible to minimize battery drain, and do not push the starter button for more than 10 seconds at any one time.  
**NOTE:** If either the check engine indicator or the low oil pressure indicator does not go out after the engine starts, stop the engine. See either Check Engine Indicator, page 42, or Low Oil Pressure Indicator, page 43.

### Caution

Do not rev the engine or put the transmission in gear immediately after starting the engine. Allow the engine to idle for about one minute after a cold start, or 30 seconds after a warm start to allow the oil to reach all areas requiring lubrication before the engine is put under load.

---

## Shifting Gears

### **⚠ WARNING**

The clutch must be fully disengaged (clutch lever pulled completely in toward the handlebars) before you attempt to shift gears. Forced shifting (shifting without the clutch disengaged) may damage the engine, transmission and drive train, causing loss of control of the motorcycle.

The motorcycle is equipped with either a five-speed or a six-speed transmission. On six-speed models, the sixth gear is overdrive. Five-speed models will not have overdrive. Refer to the specifications section beginning on page 164 for the transmission type for your model.

**TOE SHIFT PEDAL:** Shift to a higher gear by lifting the front of the pedal with your toe. To shift to a lower gear, depress the pedal with your toe.

**HEEL / TOE SHIFT PEDAL:** Shift to a higher gear by lifting the front peg of the pedal with your toe, or depress the rear peg of the pedal with your heel. To shift to a lower gear, depress the front pedal with your toe.

Neutral position is between first and second gear. The transmission is in neutral when the motorcycle moves forward or backward freely while the clutch is engaged (clutch lever released). With the ignition switch set to the ON position, the neutral indicator illuminates when the transmission is in neutral.

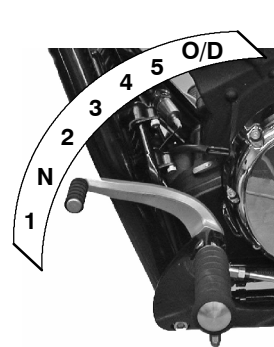

Toe Shift Pedal

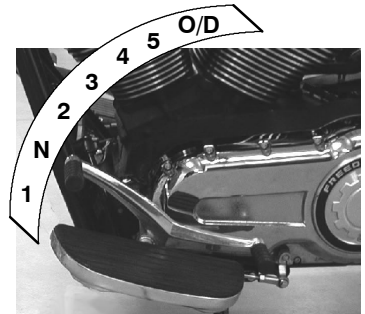

Heel/Toe Shift Pedal

# OPERATION

## Shifting Gears

1. To engage first gear, start the engine (see Starting the Engine on page 71).
2. With the engine at idle speed, engage the front brake (squeeze the brake lever) and disengage the clutch (squeeze the clutch lever).
3. Push the shift pedal down until you feel it stop in first gear.
4. Disengage the front brake (release the brake lever).
5. Simultaneously moving both the clutch lever and the throttle control grip with a smooth, gentle motion, gradually engage the clutch (release the clutch lever) and open the throttle (roll the throttle control grip toward you). As the clutch begins to engage, the motorcycle begins to move forward.
6. To shift to the next higher gear, accelerate smoothly and easily to the recommended shift point (see Recommended Shift Points on page 75).
7. With a quick motion, simultaneously close the throttle completely and disengage the clutch.
8. Raise the shift pedal with your toe, or depress it with your heel, until you feel it stop at the next gear.
9. Simultaneously moving both the clutch lever and the throttle with a smooth, gentle motion, gradually release the clutch lever and open the throttle.

**NOTE:** Within the recommended speed ranges (see Recommended Shift Points on page 75), you can downshift (shift to a lower gear) to slow the motorcycle or to increase the available power. You may want to downshift when climbing a hill or passing. Downshifting also helps to decrease your speed when combined with closing the throttle.

10. To shift to a lower gear, simultaneously pull in the clutch lever and close the throttle. Shift into the next lower gear by depressing the shift pedal with your toe. Simultaneously release the clutch lever and open the throttle.

## Shifting Gears

### **WARNING**

- Downshifting at a speed in excess of the recommended downshift point may severely damage the transmission or cause the rear wheel to lose traction. It could also result in engine damage from running at excessive RPM. Reduce speed before downshifting and do not downshift at a speed above that in the table of recommended shift points.
- Downshifting abruptly on wet, rough, loose or slippery surfaces can cause the motorcycle to skid. When downshifting while passing over such surfaces, release the clutch lever very gradually.
- Downshifting in a curve may cause the rear wheel to lose traction. Downshift before entering a curve.

### Recommended Shift Points

The following table shows the appropriate speed at which to shift up or down to each gear.

Upshift (Acceleration) Gear Change	Upshift Speed	Downshift (Deceleration) Gear Change	Downshift Speed
1st to 2nd	18 mph (29 km/h)	O/D* to 5th	50 mph (80 km/h)
2nd to 3rd	30 mph (48 km/h)	5th to 4th	35 mph (56 km/h)
3rd to 4th	40 mph (64 km/h)	4th to 3rd	25 mph (40 km/h)
4th to 5th	50 mph (80 km/h)	3rd to 2nd	15 mph (24 km/h)
5th to O/D*	60 mph (97 km/h)	2nd to 1st	10 mph (16 km/h)

\* 100/6 engine (6 Speed) only

## OPERATION

### Accelerating

To accelerate, open the throttle (roll the throttle control grip toward you). For even acceleration, open the throttle with a smooth, continuous motion. When you reach the recommended speed for upshifting, shift up one gear according to the instructions in Shifting Gears, page 73. The more quickly you open the throttle, the more quickly the motorcycle accelerates.

#### **WARNING**

- **Abrupt acceleration can cause your body to shift suddenly toward the rear of the motorcycle.**
  - **Accelerating abruptly on wet, rough, loose, or slippery surfaces may cause the rear wheel to lose traction. When accelerating on such surfaces, whether you are at a stop or already in motion, open the throttle gradually.**
-

## Braking

To slow the motorcycle with the brakes, close the throttle and apply the front and rear brakes evenly. As the motorcycle slows, either disengage the clutch or downshift each time your speed reaches a downshift point. Applying slightly more front brake than rear brake generally gives you the best braking performance. Do not apply the brakes so forcefully or quickly that either wheel stops rotating. Leave sufficient distance so you can apply the brakes gradually if you need to stop.

### **WARNING**

- **Do not apply either brake so strongly that the wheel stops rotating. This may cause loss of control.**
  - **Braking hard on wet, rough, loose, or slippery surfaces can cause the motorcycle to skid, and you could lose control of the motorcycle. Apply the brakes lightly on such surfaces.**
  - **Braking while in a curve can cause loss of control. Bring the motorcycle to the upright position before applying the brakes, and avoid applying the brakes in a corner if at all possible.**
-

# OPERATION

## Stopping the Engine

Before stopping the engine, bring the motorcycle to a complete stop either in neutral or with the clutch disengaged. Once the motorcycle is at a complete stop, if it is not already in neutral, shift into neutral. To stop the engine, set the engine stop/run switch to the STOP position, turn the ignition switch to the OFF position, and remove the ignition key.

**NOTE:** Idle air control (IAC) noise is a normal engine management calibration process that occurs each time the engine stop/run switch is put into the STOP position or when the key is turned off.

### **WARNING**

- **Stopping the engine while the motorcycle is in motion and the transmission is engaged may damage the engine and the transmission or cause the rear wheel to lose traction. In either case, you may lose control.**
  - **If the motorcycle is in motion and the engine stops on its own, guide the motorcycle to a safe location off the road and away from traffic.**
-

## Parking the Motorcycle

When parking the motorcycle, choose a flat, firm surface. Bring the motorcycle to a complete stop and, with the transmission in neutral, stop the engine. Fully extend the sidestand, turn the handlebars to the left, and lean the motorcycle to the left until the sidestand firmly supports the motorcycle. Take the key with you.

If you must park on a slope, point the motorcycle toward the top of the slope. Put the transmission in gear and park the motorcycle so that it is stable when it rests on the sidestand.

If you must park on a soft surface, use a sidestand plate under the foot of the sidestand to provide a firm surface. The sidestand footrest must be strong enough and large enough to support the motorcycle's weight without sinking into the parking surface. Many motorcyclists carry a sidestand plate.



# OPERATION

## Parking the Motorcycle

### Caution

Asphalt pavement can become soft in hot weather. The sidestand can sink into soft asphalt until the motorcycle falls over. When parking on asphalt in hot weather, use a sidestand footrest under the foot of the sidestand to prevent the sidestand from sinking into the asphalt.

---

### WARNING

**A hot engine or hot exhaust pipes can be hazardous. The engine and exhaust pipes are hot for some time after the engine is stopped. Touching the engine or exhaust pipes while hot can cause serious burns. Allowing flammable materials to contact a hot engine or exhaust pipes may cause a fire. Park the motorcycle where people will not touch the engine or exhaust pipes and where it is not near flammable materials.**

---

# MAINTENANCE

This section includes information for maintaining your VICTORY motorcycle. It includes recommended periodic maintenance intervals, which outlines the regular service required to keep your motorcycle in the best operating condition. Regular service increases motorcycle durability, safety, and dependability, and it provides greater riding pleasure. Also refer to the safety-related maintenance information beginning on page 22.

Before you begin any maintenance procedure, read the instructions for the entire procedure in this section of the *Owner's Manual*. Choose a flat, firm surface for servicing the motorcycle. Make sure you have the time, tools, and expertise to complete a procedure properly.

During maintenance you might use products that are potentially hazardous; such as oil or brake fluid. When using any of these products, follow the instructions and warnings on the product packaging.

For information on major repairs, see the *VICTORY Service Manual*. Major repairs typically require the technical skills and specially designed tools available from your authorized VICTORY dealer.

Your VICTORY dealer has the equipment and training required to properly perform emission system maintenance and repairs.

# MAINTENANCE

## Initial Maintenance

Perform the initial maintenance after you've ridden your new motorcycle 500 miles (800 kilometers). This maintenance is one of the most important services your motorcycle requires and should be performed by an authorized VICTORY dealer. Initial maintenance includes servicing all adjustments, tightening all fasteners, and changing engine oil. Performing this maintenance at the required mileage point helps the engine maintain top performance for its entire service life.

## Periodic Maintenance Intervals

Use the following table to determine how often you should perform maintenance on various components. For additional information on maintenance operations for each component listed in the table, refer to the instructions in this section.

### Caution

If you regularly ride your motorcycle at high or low speed for extended periods of time, or in dusty or other adverse conditions, perform the required maintenance more frequently to help keep your motorcycle in safe operating condition.

---

### Notice

Use the space provided at the back of this manual to record information about maintenance performed on your motorcycle.

# MAINTENANCE

## Periodic Maintenance Interval Table

Component (see operation codes below)	See Page	ODOMETER READING in MILES (KILOMETERS)																				
		500 (800)	2,500 (4,000)	5000 (8,000)	7,500 (12,000)	10,000 (16,000)	12,500 (20,000)	15,000 (24,000)	17,500 (28,000)	20,000 (32,000)	22,500 (36,000)	25,000 (40,000)	27,500 (44,000)	30,000 (48,000)	32,500 (52,000)	35,000 (56,000)	37,500 (60,000)	40,000 (64,000)	42,500 (68,000)	45,000 (72,000)	47,500 (76,000)	50,000 (80,000)
Air Filter***	91	I	I	I	I	R	I	I	I	R	I	I	I	R	I	I	I	R	I	I	I	R
Battery	133	I	I	I	I	I	I	I	I	I	I	I	I	I	I	I	I	I	I	I	I	I
Brake Fluid**	119,122	I	I	I	I	I	I	I	I	I	I	I	I	R	I	I	I	I	I	I	I	I
Brake Pads	124	I	I	I	I	I	I	I	I	I	I	I	I	I	I	I	I	I	I	I	I	I
Clutch Fluid** (Hydraulic)	113	I	I	I	I	I	I	I	I	I	I	I	I	R	I	I	I	I	I	I	I	I
Clutch Lever	111	I	I	I	L	I	I	L	I	I	I	I	L	I	I	L	I	I	I	L	I	L
Control Cables	116	I	I	I	L	I	I	L	I	I	I	I	L	I	I	L	I	I	I	L	I	L
Crankcase Ventilation System	107	I	I	I	I	I	I	I	I	I	I	I	I	I	I	I	I	I	I	I	I	I
Drive Belt	92	I	I	I	I	I	I	I	I	I	I	I	I	R	I	I	I	I	I	I	I	I
Engine Compression	131	I	I	I	I	I	I	I	I	I	I	I	I	I	I	I	I	I	I	I	I	I
Engine Oil*	88	R	R	R	R	R	R	R	R	R	R	R	R	R	R	R	R	R	R	R	R	R
Engine Oil Filter*	88	R	R	R	R	R	R	R	R	R	R	R	R	R	R	R	R	R	R	R	R	R

**Operation Codes:**  
 I-Inspect (tighten, clean, adjust, correct or replace if necessary)    R-Replace/Rebuild    L-Lubricate with proper lubricant    P-Perform  
 \*Replace at specified interval or annually. If driven in extreme conditions, engine oil and filter should be changed every 2,500 miles (examples: frequent operation in stop-and-go traffic, short trips, dusty conditions, fully loaded, aggressive riding, high ambient temperatures).  
 \*\*Replace at specified interval or every 2 years                                \*\*\*Change every 5,000 miles if operated regularly in dusty environments

# MAINTENANCE

## Periodic Maintenance Interval Table (continued)

Component (see operation codes below)	See Page	ODOMETER READING in MILES (KILOMETERS)																				
		500 (800)	2,500 (4,000)	5,000 (8,000)	7,500 (12,000)	10,000 (16,000)	12,500 (20,000)	15,000 (24,000)	17,500 (28,000)	20,000 (32,000)	22,500 (36,000)	25,000 (40,000)	27,500 (44,000)	30,000 (48,000)	32,500 (52,000)	35,000 (56,000)	37,500 (60,000)	40,000 (64,000)	42,500 (68,000)	45,000 (72,000)	47,500 (76,000)	50,000 (80,000)
Exhaust System	131	I	I	I	I	I	I	I	I	I	I	I	I	I	I	I	I	I	I	I	I	
Evaporative Emission Control System (California Only)	107	I		I		I		I		I		I		I		I		I		I		
Fasteners	142	I		I		I		I		I		I		I		I		I		I		
Front Brake Lever	117	I		I		L		I		L		I		L		I		L		I		L
Front Fork Oil**	105	I		I		I		R		I		I		R		I		I		R		I
Front Forks/Front Axle	106	I		I		I		I		I		I		I		I		I		I		I
Fuel Filter	108													R								R
Fuel System	107	I	I	I	I	I	I	I	I	I	I	I	I	I	I	I	I	I	I	I	I	I
Gear Shift Pedal	126	I		I		L		I		L		I		L		I		L		I		L
Headlamp	138	I				I				I				I				I				I
<p><b>Operation Codes:</b></p> <p>I-Inspect (tighten, clean, adjust, correct or replace if necessary)      R-Replace/Rebuild      *Replace at specified interval or annually</p> <p>L-Lubricate with proper lubricant      P-Perform      **Replace at specified interval or every 2 years</p> <p>***Change every 5,000 miles if operated regularly in dusty environments</p>																						

# MAINTENANCE

## Periodic Maintenance Interval Table (continued)

Component (see operation codes below)	See Page	ODOMETER READING in MILES (KILOMETERS)																				
		500 (800)	2,500 (4,000)	5000 (8,000)	7,500 (12,000)	10,000 (16,000)	12,500 (20,000)	15,000 (24,000)	17,500 (28,000)	20,000 (32,000)	22,500 (36,000)	25,000 (40,000)	27,500 (44,000)	30,000 (48,000)	32,500 (52,000)	35,000 (56,000)	37,500 (60,000)	40,000 (64,000)	42,500 (68,000)	45,000 (72,000)	47,500 (76,000)	50,000 (80,000)
Rear Brake Pedal	121	I		I		L		I		L		I		L		I		L		I		L
Rear Wheel Alignment	97	I		I		I		I		I		I		I		I		I		I		I
Rear Shock Absorber	100							I						I						I		R
Road Test	142	P	P	P	P	P	P	P	P	P	P	P	P	P	P	P	P	P	P	P	P	P
Sidestand	66	I		I		L		I		L		I		L		I		L		I		L
Sidestand Rubber Pad	66	I	I	I	I	I	I	I	I	I	I	I	I	I	I	I	I	I	I	I	I	I
Spark Plugs	129	I		I		I		I		I		I		R		I		I		I		I
Steering Bearings	106	I	I	I	I	I	I	L	I	I	I	I	I	L	I	I	I	I	I	L	I	I
Swing Arm and Rear Axle	104	I		I		I		I		I		I		I		I		I		I		I
Throttle/Throttle Cables	109,116	I	I	I	I	L	I	I	I	L	I	I	I	L	I	I	I	L	I	I	I	L
Tires	127	I	I	I	I	I	I	I	I	I	I	I	I	I	I	I	I	I	I	I	I	I

**Operation Codes:**

I-Inspect (tighten, clean, adjust, correct or replace if necessary)      R-Replace/Rebuild      \*Replace at specified interval or annually

L-Lubricate with proper lubricant      P-Perform      \*\*Replace at specified interval or every 2 years

\*\*\*Change every 5,000 miles if operated regularly in dusty environments

# MAINTENANCE

MAINTENANCE RECORD			
MAINTENANCE PERFORMED	MILES / KM	NOTES	PERFORMED BY:

**MAINTENANCE**

<b>MAINTENANCE RECORD</b>			
<b>MAINTENANCE PERFORMED</b>	<b>MILES / KM</b>	<b>NOTES</b>	<b>PERFORMED BY:</b>



# MAINTENANCE

## Engine Oil

### Change Engine Oil and Oil Filter

#### WARNING

**A hot engine or hot exhaust pipes can be hazardous. The engine and exhaust pipes are hot for some time after the engine is stopped. Touching the engine or exhaust pipes while hot can cause serious burns. Allowing flammable materials to contact a hot engine or exhaust pipes may cause a fire. Park the motorcycle where people will not touch the engine or exhaust pipes and where it is not near flammable materials.**

---

1. Start and run the engine until it reaches normal operating temperature. Stop the engine.
2. Securely support the motorcycle on the sidestand.
3. Place a drain pan under the drain plug and oil filter.
4. Remove the drain plug and seal using the universal tool (provided under the left side cover) or a good quality 6mm hexagonal socket. Allow the oil to drain completely.
5. Use an oil filter wrench to slowly loosen the filter. Allow oil in the filter to drain before removing the filter.
6. Reinstall the drain plug with a new seal.

**Torque: 15 ft-lbs (20 Nm)**

7. Clean any residue or debris from oil filter mounting plate and threads.

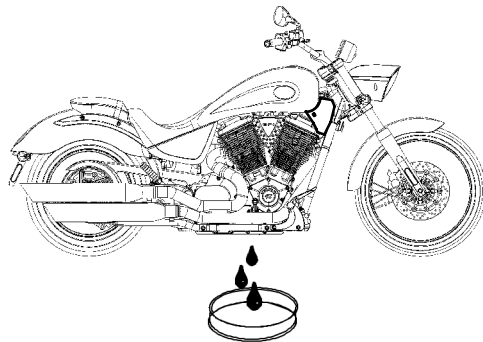

## Engine Oil

### Change Engine Oil and Oil Filter

8. Make sure the new oil filter gasket is properly seated in the oil filter, and apply a thin film of clean engine oil to the gasket. Screw the new filter on until the gasket contacts the filter mounting plate. Tighten the filter *by hand* an additional 3/4 turn.
9. Fill the crankcase through the oil fill cap with about 8.75-9.0 pints (4.0-4.25 liters) of oil. We recommend the use of only VICTORY Brand Semi-Synthetic 20W-40 Motor Oil or an equivalent oil designed for use with wet clutches (such as those with a JASO MA rating).
10. Reinstall the oil fill cap and then start and run the engine until it reaches normal operating temperature.

### Caution

After an oil change, the low oil pressure indicator remains illuminated longer than usual before going out. Revving the engine while the low oil pressure indicator is illuminated can damage the engine.

---

11. Stop the engine and make sure there are no leaks around the drain plug and oil filter. Check the oil level and adjust if needed.

### Notice

Recycle used oil and oil filter in accordance with local regulations.

# MAINTENANCE

## Engine Oil

### Check Engine Oil Level

1. With the transmission in neutral, start and run the engine for several minutes.
2. Shut the engine off and wait for 3-5 minutes.
3. With the engine at normal operating temperature, straddle the motorcycle on level ground and bring it to a vertical position. Remove the oil fill cap and wipe the dipstick clean. Reinstall the dipstick and turn the cap clockwise until it seats.
4. Remove the dipstick again and note the oil level.
5. If necessary, add or remove oil to bring the level into the area on the dipstick, above the ADD mark and below the FULL mark (see page 53). Repeat steps 1-2 each time you adjust the oil level.

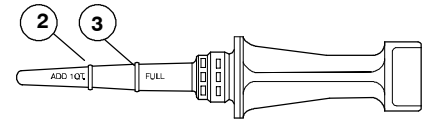
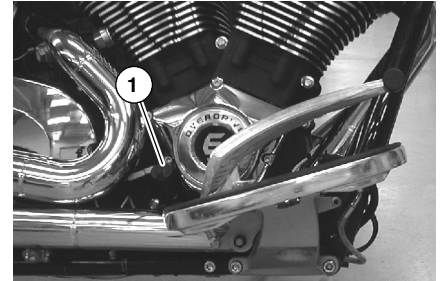

1. Oil Fill Cap/Dipstick
2. ADD Mark
3. FULL Mark

### **!** WARNING

**Do not operate the motorcycle with the oil level above the FULL mark or below the ADD mark. Operating the engine with too much or too little oil can cause serious engine damage or engine seizure, resulting in loss of control of the motorcycle.**

## Inspect Air Filter

The standard VICTORY air filter element is a dry paper design and does not require the use of air filter oil.

**Notice** Inspect the air filter often if riding in unusually wet or dusty conditions.

1. Remove the air filter access cover and air filter element using the universal tool provided under the left side cover (see page 142).
2. To remove debris from the element, use low-pressure air and blow from the rear forward.

### **! WARNING**

**Wear face protection when using pressurized air.**

3. Apply a small amount of lubricant to the edge of the air filter element frame and reinstall the element and access cover. Do not over-tighten the access cover screws.

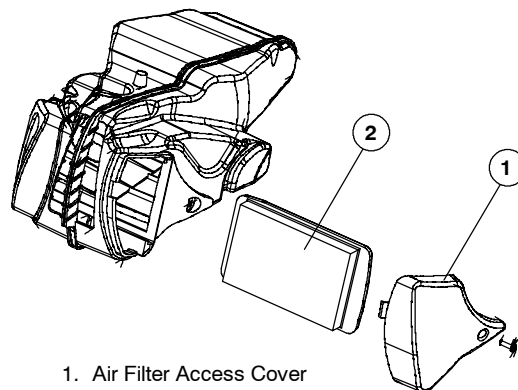

1. Air Filter Access Cover
2. Air Filter Element

# MAINTENANCE

## Drive Belt

### Check Drive Belt Condition

Replace the drive belt if it is cracked or has broken teeth or frayed edges. No matter its condition, the drive belt should be replaced at periodic intervals (see the *VICTORY Service Manual* or an authorized VICTORY dealer). DO NOT attempt to check belt tension if the belt has been exposed to rain or washing within a 24 hour period or if the belt is hot from riding. Allow the belt to cool down to ambient temperature before measuring belt tension. Replace drive belt and both sprockets as a set if drive belt has over 5,000 miles (8,000 km) of service at the time of damage or failure.

### Check Drive Belt Tension

This procedure involves using the belt tension gauge, part no. PV-43532, which is designed specifically for measuring drive belt tension.

Before beginning this procedure:

- Make sure the drive belt is dry and at room temperature.
- Make sure the rear suspension is properly adjusted (see Adjust Rear Shock Absorber, page 100).

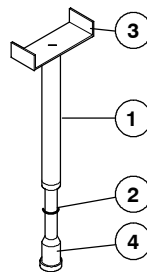

1. Belt Tension Gauge
2. Small O-Ring
3. Base
4. Plunger

## Drive Belt Check Drive Belt Tension

Drive Belt Deflection (with 10 lbs. of force)		
	VEGAS LOW	VEGAS / VEGAS 8-BALL / ALL KINGPIN
New drive systems (new belt & sprockets)	5 mm +/- 0.5 mm (13/64" +/- 1/64")	12 mm +/- 1 mm (15/32" +/- 1/32")
After 500 miles on drive system	6 mm +/- 0.5 mm (15/64" +/- 1/64")	12 mm +/- 1 mm (15/32" +/- 1/32")

The following data is provided for use with a Sonic Tension Meter. Follow the instructions provided with the meter.

Required Data		Required Data	
Span	658.3mm	Tension (new belt)	50.6 Hz
Belt width	28mm	Tension (after 500 miles)	48.3 Hz
Belt mass constant	7.9		

### Drive Belt Wear Analysis

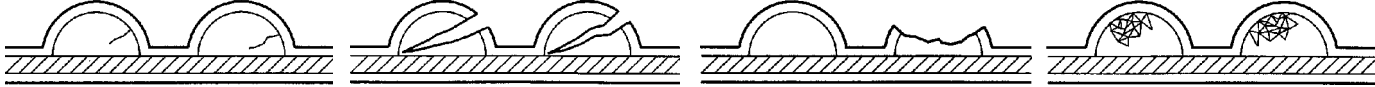

Internal tooth cracks (hairline): OK to run, but monitor condition	External tooth cracks: Replace belt	Missing teeth: Replace belt	Chipping (not serious): OK to run, but monitor condition
---	--	--------------------------------	---

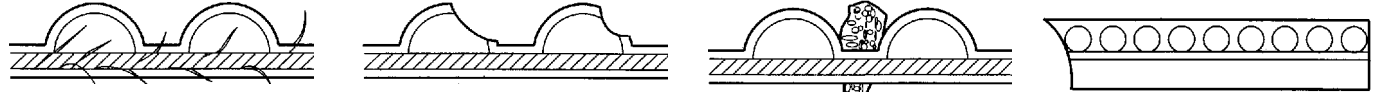

Fuzzy edge cord: OK to run, but monitor condition	Hook wear: Replace belt	Stone damage: Replace belt if damage is on edge	Bevel wear (outboard edge only): OK to run, but monitor condition
--	----------------------------	--	--

# MAINTENANCE

## Drive Belt

### Check Drive Belt Tension

1. Place the transmission in Neutral and lift the rear wheel off the ground with an appropriate motorcycle lift or a block of wood or steel placed securely under the frame.

#### **WARNING**

**Care should be taken to be sure the motorcycle will not tip or fall while elevated. Severe personal injury or death may occur if the motorcycle tips or falls.**

---

2. Position the small O-ring on the belt tension gauge directly over the 10 lbs. mark on the plunger as shown.
3. Place a tape measure or rule next to the drive belt as shown.

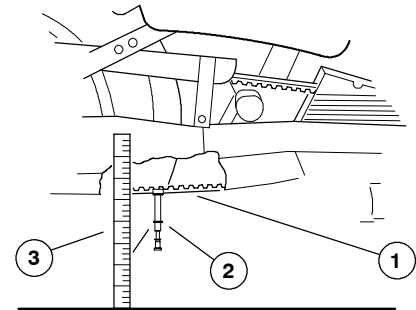

1. Drive Belt
2. Belt Tension Gauge
3. Rule

## Drive Belt

### Check Drive Belt Tension

4. Place the base of the tension gauge bracket squarely against the lower strand of the drive belt halfway between the front and rear drive sprockets. Use the tape measure or ruler and record the position of the base of the tension gauge bracket. This position represents *zero force*.
5. Push the plunger upward until the small O-ring touches the tension gauge body. Make sure the tension gauge is seated squarely against the drive belt, and record the position of the base of the tension gauge bracket. This position represents *10 lbs. force*.
6. Calculate the difference between the *zero force* position and the *10 lbs. force* position you recorded. Refer to the chart on page 93 for belt specifications.
7. Belt deflection must be measured and adjusted with the belt at the tightest spot. Measure the belt deflection in 4 spots by rotating the wheel 90 degrees in the forward direction between measurements. Adjust belt tension as necessary. See page 96.

#### Important Drive Belt Deflection Information

- Measure / adjust belt deflection at tightest spot
- Belt and sprockets must be clean, dry, and at room temperature for accurate deflection measurement
- Lowering kits affect belt deflection specifications. Consult an authorized Victory dealer if a lowering kit is installed on your motorcycle.
- When a new drive belt is installed, tension must be adjusted after 500 miles to ensure maximum belt service life.



# MAINTENANCE

## Drive Belt

### Adjust Drive Belt Tension

#### WARNING

Care should be taken to be sure the motorcycle will not tip or fall while elevated. Severe personal injury or death may occur if the motorcycle tips or falls.

**Notice** Before adjusting drive belt tension, inspect wheel alignment. See page 97.

1. Loosen the rear axle nut (1) on the left end of the rear axle. On screw-style adjusters, loosen the lock nut (2) on both the left and right axle adjusters.
2. Turn the axle adjusters (3) clockwise (viewed from rear) an equal amount if wheel is in alignment, or turn each adjuster as needed to align the wheel *and* achieve proper tension. See Check Drive Belt Tension, page 92. Use an 8mm hex tool on screw-style adjusters.
3. When alignment and belt tension is correct, tighten the rear axle nut. Tighten the adjuster lock nut (screw-style adjusters).

**Torque: 65 ft-lbs (88 Nm)**

4. Recheck drive belt tension and wheel alignment.
5. Pump rear brake pedal several times to reset brake pad distance.
6. Slowly rotate the rear wheel. If the wheel does not rotate smoothly, inspect the wheel bearings, axle and brakes. Refer to the Service Manual or contact an authorized Victory dealer.

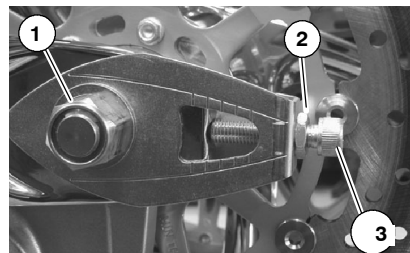

Screw-style adjuster

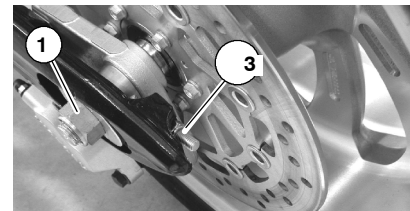

Nut-style adjuster

## Rear Wheel Alignment

**⚠ WARNING**

A skewed rear axle can damage the drive belt, causing belt failure and loss of control of the motorcycle.

---

1. Bring the motorcycle to a vertical position.
2. Place the transmission in Neutral and lift the rear wheel off the ground with an appropriate motorcycle lift or a block of wood or steel placed securely under the frame.
3. The axle adjusters or plates (1) are stamped with marks (2) that are used as a reference to ensure proper wheel alignment. Inspect the position of the alignment marks on each side in relation to the mark stamped on swingarm (3). The marks should be in the same position on both left and right sides of the wheel.
4. To adjust the rear wheel alignment, loosen the rear axle nut about 1 1/2 turns.

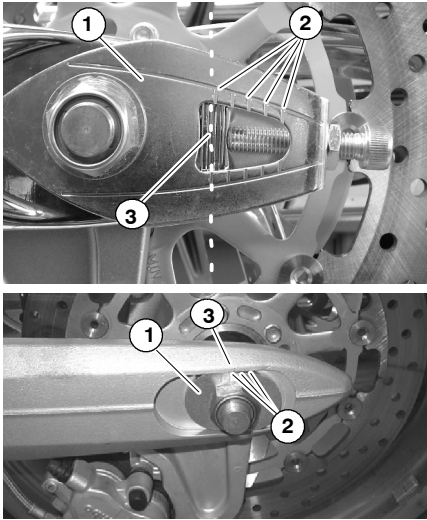

# MAINTENANCE

## Rear Wheel

### Alignment

**NOTE:** Turn the axle adjusters about 1/16 of a turn at a time and monitor wheel alignment as you proceed.

5. On screw style adjusters: Use a 17mm wrench to loosen lock nut (4), then an 8mm hexagonal wrench to turn the axle adjuster screws (5).

On nut style adjusters: Use a deep 14mm socket to turn the adjuster nut (6).

6. On both styles: Turn the screw or nut IN (clockwise) to draw the axle back, or OUT (counterclockwise) to allow the axle to move forward.

**NOTE:** If adjuster screws or nuts are turned OUT (counterclockwise) push the wheel and axle forward to be sure the end of adjuster screws or the nuts are seated against the end of the swingarm before inspecting alignment or belt tension.

7. Recheck rear wheel alignment after each adjustment. Readjust if necessary until alignment is correct and drive belt tension is correct (see Check Drive Belt Tension, page 92).

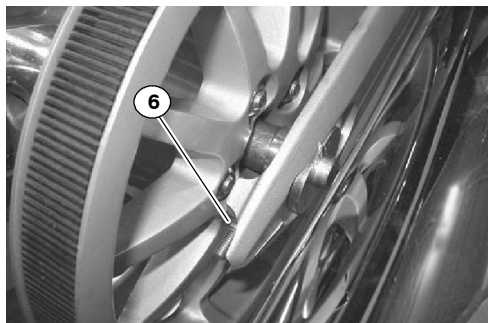

## Rear Wheel

### Alignment

8. When wheel is aligned and drive belt tension is correct, tighten the adjuster lock nut (screw-style), then tighten the axle nut.

**Torque: 65 ft-lbs (88 Nm)**

9. Recheck drive belt tension and alignment to be sure it is correct after tightening the axle.
10. If alignment is incorrect, repeat steps 4-8.
11. Pump rear brake pedal several times to reset brake pad distance.
12. Carefully lower the motorcycle and safely support it on the sidestand.



### **WARNING**

**Care should be taken to be sure the motorcycle will not tip or fall while elevated. Severe personal injury or death may occur if the motorcycle tips or falls.**

---

# MAINTENANCE

## Rear Suspension

### Inspect Rear Shock Absorber Pre-Load (Ride Height)

This procedure involves using the shock absorber preload wrench PV-43507, a special spanner tool available from your dealer. The tool is designed specifically for adjusting shock spring preload on your motorcycle. Preload should be set with accurate load conditions before riding to ensure optimum handling, safety, and ride quality.

Have an assistant help you complete the following procedure. Refer to the illustration on page 101.

1. Set front and rear tire pressure to specification (page 127).
2. Load the motorcycle with all cargo you intend to carry. With the motorcycle in the upright position, sit on the operator's seat with your riding gear on. If you plan on carrying a passenger, have them sit on the passenger seat with their riding gear on.
3. Compress the rear suspension a few times by pushing on the seat and slowly releasing. Make sure the suspension moves freely without binding.
4. With as much of your weight on the seat as possible, have your assistant measure the distance from the floor to the rearmost flat section of right side frame cradle.
5. Record the measurement and compare to specification.

Ride Height Specifications	
VEGAS LOW	120 mm (4 3/4") +/- 3 mm (1/8")
VEGAS / VEGAS 8-BALL	131 mm (5 5/32") +/- 3 mm (1/8")
KINGPIN / KINGPIN 8-BALL / KINGPIN TOUR	127 mm (5.0") +/- 3 mm (1/8")

## Rear Suspension

### Inspect Rear Shock Absorber Preload (Ride Height)

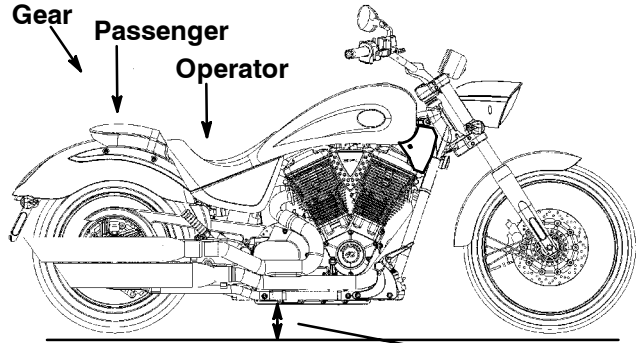

Motorcycle in upright position  
Weight of Operator, Passenger, Gear in position

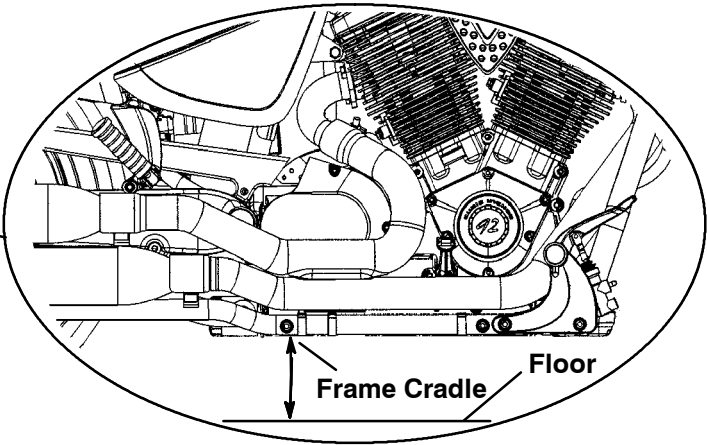

Measure from floor to rearmost flat section of right side frame cradle.

# MAINTENANCE

## Rear Suspension

### Adjust Rear Shock Absorber Preload (Ride Height)

To adjust the shock absorber spring pre-load:

1. Rest the motorcycle on the sidestand. Remove the right side cover (page 48).
2. Remove the fuse box from right panel by lifting upward on the tab at the rearward end while pulling the fuse box rearward (page 137). Make sure that the rear brake fluid reservoir cap is secured to prevent fluid loss (page 122).
3. Remove three 10mm bolts (1) holding the fuse box bracket to chassis.
4. Remove the on-board diagnostics connector from the fuse box bracket by squeezing the connector lock and pulling the connector apart. Leave the terminated end attached to the fuse box bracket.
5. Remove the wire harness dart from the fuse box bracket by sliding the connector off the dart clip.
6. Carefully pull and rotate the fuse box bracket toward the front of the motorcycle.

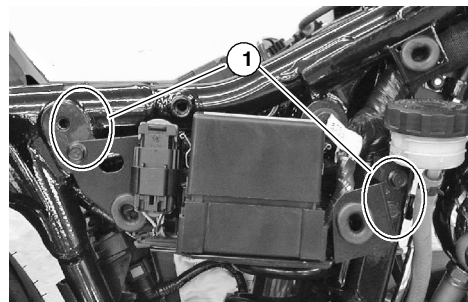

## Rear Suspension

### Adjust Rear Shock Absorber Preload (Ride Height)

7. The uppermost spanner nut on the shock is the locknut (1). The spanner nut closest to the spring is the adjuster nut (2). Loosen the locknut by turning it counterclockwise (as viewed from the top of shock absorber) with the spanner wrench.
8. Spray a light lubricant on the adjuster nut where it contacts the spring. DO NOT allow spray to contact the drive belt.
9. Adjust shock absorber preload by rotating adjuster nut clockwise (as viewed from the top of shock absorber) to INCREASE the ride height measurement (firm), and counterclockwise to DECREASE the ride height measurement (softer). Re-check ride-height dimension after adjustment.
10. Tighten lock nut securely against adjuster nut when adjustment is complete.
11. Reinstall fuse box bracket and securely tighten the 3 bolts that secure panel to chassis.
12. Re-install fuse box and right side cover.

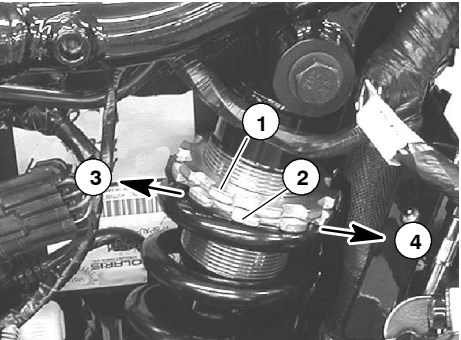

1. Preload Adjustment Locknut
2. Preload Adjuster Nut
3. Increase Ride Height Measurement
4. Decrease Ride Height Measurement



# MAINTENANCE

## Rear Suspension

### Inspect Swing Arm and Rear Axle

1. Sit in the operator's seat and slowly bounce the rear suspension a few times. Make sure the suspension moves freely without binding.
2. Elevate the rear of the motorcycle until the rear wheel is off of the ground. Use an appropriate motorcycle lift or a block of wood or steel placed securely under the frame.
3. Grasp the rear tire and attempt to move the rear wheel side-to-side.  
**NOTE:** If there is movement at the rear axle, inspect the wheel bearings and rear axle (see the *VICTORY Service Manual* or an authorized VICTORY dealer).  
If there is movement at the front of the swing arm, check the swing arm pivot nut torque. If movement is still present, inspect the swing arm pivot bushings (see the *VICTORY Service Manual* or an authorized VICTORY dealer).
4. With the transmission in neutral, slowly rotate the rear wheel. If the wheel does not rotate smoothly, inspect the wheel bearings, rear axle, belt adjustment, and wheels alignment (see the *VICTORY Service Manual* or an authorized VICTORY dealer).

## Front Suspension and Steering

### **! WARNING**

Care should be taken to be sure the motorcycle will not tip or fall while elevated. Severe personal injury or death may occur if the motorcycle tips or falls.

### Check Front Forks

1. To check the front suspension, straddle the motorcycle and bring it to a vertical position.
2. Apply the front brake and push down hard on the handlebars several times. The front suspension should operate smoothly and quietly.
3. Place the motorcycle on the sidestand and inspect the front forks. Make sure there is no fork oil present on the fork tube (1) or around the fork seal (2).
4. Clean the fork tubes as required to remove bugs, tar, or buildup which may cause seal wear or leakage.

### Replace Front Fork Oil

Front fork oil condition and level is associated with front suspension performance and internal component wear. For fork oil replacement procedures and special tools required, see the *VICTORY Service Manual* or contact an authorized VICTORY dealer.

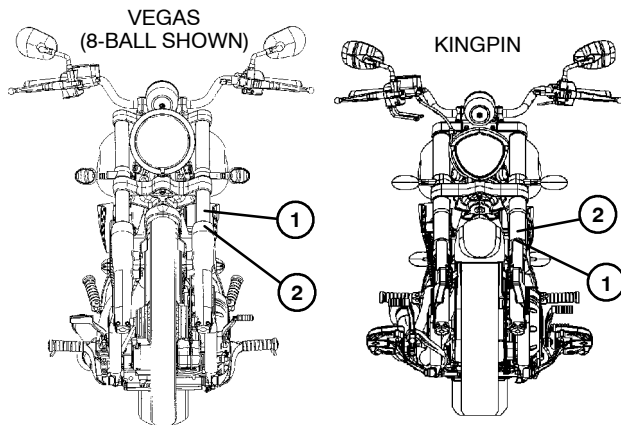

1. Front Fork Tube
2. Fork Seal

# MAINTENANCE

## Front Suspension and Steering

### WARNING

Care should be taken to be sure the motorcycle will not tip or fall while elevated. Severe personal injury or death may occur if the motorcycle tips or falls.

---

### Inspect Steering and Front Axle

1. Elevate the front of the motorcycle until the front wheel is off of the ground. Use an appropriate motorcycle lift or a block of wood or steel placed securely under the frame.
2. Turn the handlebars from stop to stop. The action should be smooth but not loose or interfered with by wires, hoses, or control cables.
3. Point the front wheel straight ahead. Grasp the front forks near the front axle and attempt to move the front wheel front-to-back. **NOTE:** If there is front-to-back movement at the steering head, the steering head bearings should be inspected, lubricated, and adjusted (see the *VICTORY Service Manual* or an authorized VICTORY dealer).

**Notice** The steering head bearings require periodic lubrication even if there is no front-to-back movement at the steering head when checked (see the *VICTORY Service Manual* or an authorized VICTORY dealer).

4. Turn the handlebars all the way to the right or left. Grasp the front tire and attempt to move the front wheel side-to-side.  
**NOTE:** If there is movement at the front axle, inspect the wheel bearings and front axle (see the *VICTORY Service Manual* or an authorized VICTORY dealer).
5. Slowly rotate the front wheel. If the wheel does not rotate smoothly, inspect the wheel bearings, front axle, and brakes (see the *VICTORY Service Manual* or an authorized VICTORY dealer).

## Fuel System

### Check Fuel Hose, Rail, and Connections

Inspect the fuel hoses for cracks or damage. Inspect the hose connection at the fuel pump and at the fuel rail for dampness or stains from leaking or dried fuel.

### Check Crankcase Ventilation Hose and Connections

Remove the operators seat and fuel tank. Inspect the crankcase ventilation hose for cracks or damage. Inspect the hose connection at the air cleaner and at the crankcase for dampness or stains from leaking.

### Evaporative Emission Control System (California models only)

Visually inspect all evaporative emission control system hoses and connections. Make sure all connections are tight. Also, inspect the evaporative canister to make sure it has not been damaged.

## Fuel Tank Removal / Installation

1. Remove the operator's seat.
2. Remove the access cover (1).
3. Remove the two front and one rear fuel tank mounting screws.
4. Unplug the fuel pump wire harness at the rear of the tank.

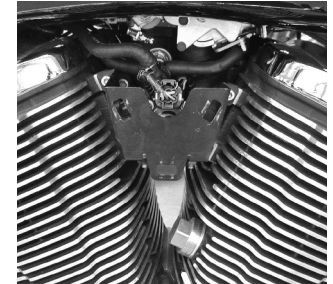
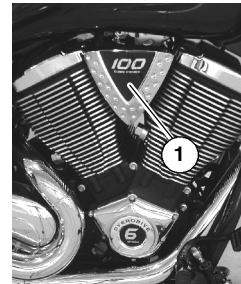

# MAINTENANCE

## Fuel System

### Caution

Fuel can damage painted surfaces and plastic parts. Wipe spilled fuel immediately from the motorcycle using a clean, dry, soft cloth.

5. With the engine and exhaust cool, wrap a clean shop towel around the fuel line fitting (2) at the fuel rail. Disconnect it from the fuel rail by squeezing both release buttons (3) simultaneously. Gently slide the fitting from the fuel rail.
6. At the rear left side of the tank, disconnect the tank vent hose (California models) and the water drain hose.
7. Carefully remove the fuel tank.
8. To reinstall the fuel tank, reverse the removal steps, routing fuel supply hose to the right of breather hose.
9. Reinstall the fuel line fitting to the fuel rail by sliding the quick-connect onto the rail connector until you hear it click.
10. Reinstall the fuel tank mounting screws.  
**Torque: 35 ft-lb. (47.5 Nm)**
11. Reinstall the fuel line access cover. Reinstall the seat.

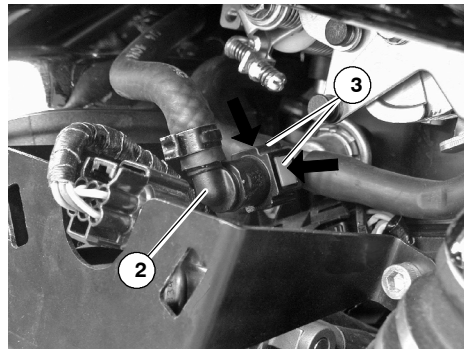

## Replace Fuel Filter

The fuel filters are attached to the electric fuel pump located inside the fuel tank. Fuel filter condition is associated with engine performance and fuel economy. For fuel filter replacement procedures and special tools required, see the *VICTORY Service Manual* or contact an authorized VICTORY dealer.

## Throttle

### Check Throttle Control Grip and Cable

1. Rotate the throttle control grip. It should rotate smoothly from its rest position to its completely open position and back again. It should return to its rest position quickly when released.
2. Throttle freeplay is the amount of throttle control grip movement from the rest position to the point of cable resistance. Freeplay should be 2-4 mm. Adjust throttle freeplay if necessary. See page 110.
3. Remove the right side access cover (1). Inspect throttle cables (2) for frayed ends.
4. Contact your Victory dealer if throttle operation is not smooth, if throttle grip does not return properly, or if cable ends are frayed.

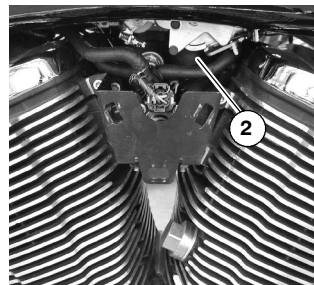
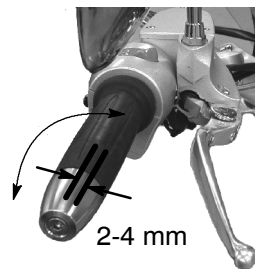

# MAINTENANCE

## Throttle

### Adjust Throttle Freeplay

1. Hold the adjuster nuts (1) and loosen the lock nuts (2) on both cables.
2. Turn the lock nuts away from the adjuster nuts as far as possible on both cables.
3. Turn both adjuster nuts toward the lock nuts as far as possible for maximum freeplay in both cables.
4. Turn the adjuster on the throttle opening (front) cable away from the lock nut until throttle freeplay is 2-4 mm.
5. To adjust the closing cable (the one toward rear of motorcycle), move the throttle grip back and forth constantly and turn adjuster out slowly just until freeplay is removed. Turn the adjuster back in one full turn.
6. Turn lock nuts on both cables until seated against adjuster nuts. Hold adjuster nut and tighten lock nut securely (both cables).
7. Check throttle control grip as described on page 109.
8. Start engine with transmission in neutral. Turn handlebars full left to full right. Idle RPM should not change when bars are turned. RPM changes can be caused by a damaged cable, incorrect routing, or incorrect adjustment.

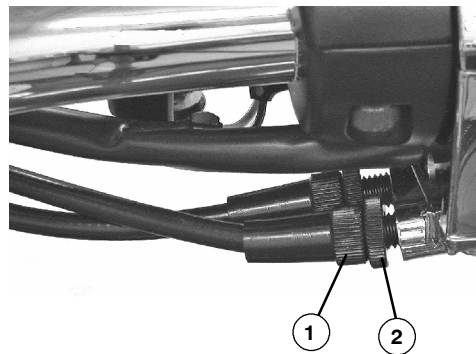

## Mechanical Clutch

### Check Clutch Lever and Cable

1. Squeeze the clutch lever toward the handlebar and release it. It should move freely and smoothly and should return to its rest position quickly when released.
2. Clutch lever freeplay is the amount of clutch lever movement from the rest position to the point of cable resistance. Freeplay (gap) should be 0.5-1.5mm. Measure the gap between the clutch lever and the lever housing. Adjust clutch lever freeplay if necessary (see page 112).

**NOTE:** The starter interlock switch is dependent on the clutch lever freeplay being set correctly to ensure activation of the clutch safety switch.

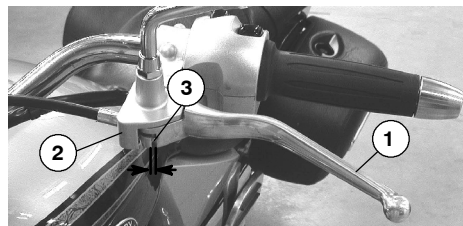

1. Clutch Lever
2. Lever Housing
3. Freeplay = 0.5-1.5 mm



# MAINTENANCE

## Mechanical Clutch

### Adjust Clutch Cable Freeplay

1. Remove the right side cover.
2. Hold cable (1) and loosen the adjuster lock nut (2).
3. Turn cable adjuster (3) while holding cable.
4. Turn the cable adjuster in or out until the clutch lever freeplay (4) is 0.5-1.5mm.
5. Tighten the adjuster lock nut securely while holding cable.
6. Reinstall right side cover.
7. Verify that the safety switch activates so the motorcycle cannot be started in gear with clutch lever released.

**NOTE:** The starter interlock switch is dependent on the clutch lever freeplay being set correctly to ensure activation of the clutch safety switch.

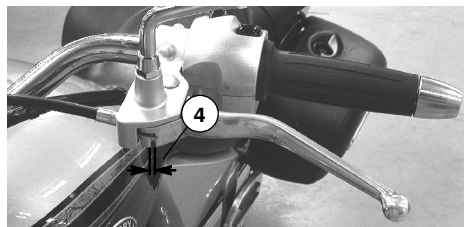
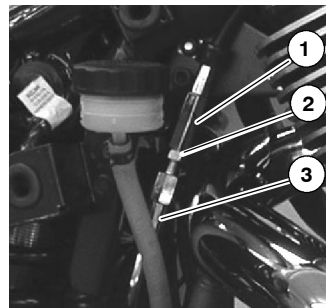

## Hydraulic Clutch

### Check Hydraulic Clutch Fluid

Check the hydraulic clutch fluid level.

1. Position the motorcycle on level ground with the front wheel straight forward. Do not use the side stand. Position the handlebars so that the clutch fluid reservoir is level.
2. View the fluid level through the sight glass. The fluid should be clear and at a level in or above the sight glass.
3. Add clutch fluid if necessary (see page 114).

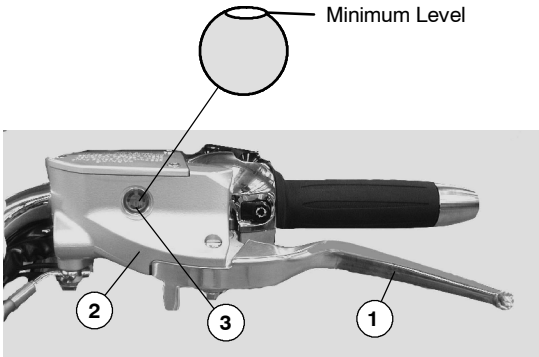

1. Clutch Lever
2. Lever Housing
3. Clutch Fluid Sight Glass

# MAINTENANCE

## Hydraulic Clutch

### Add Hydraulic Clutch Fluid

1. Straddle the motorcycle and bring it to a vertical position. Turn the handlebars until the reservoir is horizontal.
2. Wipe the area around the reservoir cover with a clean cloth.
3. Wipe the clutch fluid container with a clean cloth.
4. Remove the reservoir cover and gasket.

#### WARNING

- **Do not operate the clutch while the reservoir cover is removed. Fluid could overflow from the reservoir and cause air to enter the fluid system. Air in the fluid system could cause the clutch to malfunction.**
- **Use DOT4 brake fluid in the hydraulic clutch reservoir. Use fluid only from a sealed, clean container. Using the wrong fluid or allowing contaminants into the fluid system can damage the system seals, resulting in a clutch malfunction.**

- 
5. Carefully add enough clutch fluid to bring the level just above the sight glass.
  6. Reinstall the reservoir gasket and cover.

## Lubricate Clutch Lever

### Mechanical Clutch

1. Remove right side cover. Loosen the adjuster lock nut (see page 112.)
2. Turn the cable adjuster all the way in to provide maximum lever freeplay.
3. Remove clutch lever pivot nut (1) and pivot screw (2). Disconnect the clutch cable from the clutch lever.
4. Remove any old grease and dirt from the clutch lever and lever housing.
5. Lubricate the clutch lever and lever pivot screw with VICTORY Moly Assembly Grease or Victory All Purpose grease.
6. Reconnect the clutch cable. Reinstall the lever, pivot screw and nut. Hold pivot screw down and torque nut to 40 in-lbs (5 Nm).
7. Adjust clutch freeplay (page 112).

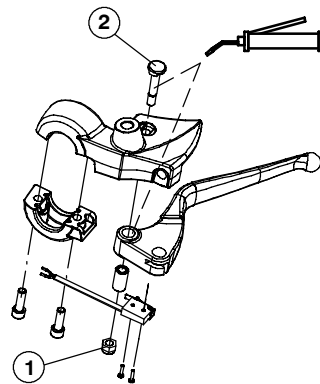

### Hydraulic Clutch

1. Remove clutch lever pivot nut (1) and pivot screw (2).
2. Remove any old grease and dirt from the clutch lever and lever housing.
3. Lubricate the clutch lever and lever pivot screw with VICTORY Moly Assembly Grease or Victory All Purpose grease.
4. Reinstall the lever, pivot screw and nut. Torque the pivot screw to 9 in-lbs (1 Nm). Torque the nut to 52 in-lbs (6 Nm).

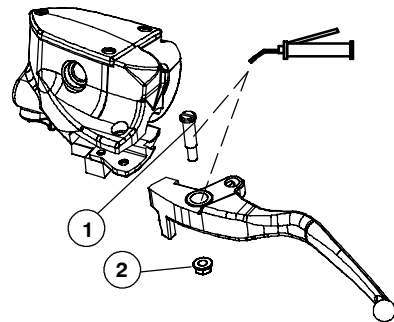

# MAINTENANCE

## Lubricate Control Cables

The following cables used on the motorcycle require periodic lubrication for smooth operation and maximum service life:

- Throttle Cables
  - Mechanical Clutch Cable
1. Loosen the adjuster of the cable to be lubricated, and disconnect one end of the cable.
  2. Lubricate the cable and the inside of the cable housing with VICTORY Cable Lube (PN 2872861) or a commercially available cable lubricant.
  3. Lubricate the cable end with VICTORY All Purpose Grease or equivalent.
  4. Reconnect the cable and adjust as necessary.

Mechanical Clutch Cable Adjustment: See page 112.

Throttle Cable Adjustment: See page 109.

## Brakes

### Check Front Brake Lever Movement

Squeeze the front brake lever toward the handlebar and release it. It should move freely and smoothly and should return to its rest position quickly when released. You should feel a firm resistance in the lever within the first 3/4-inch (19 mm) of lever travel.

If the brake lever travels too far before beginning to engage the brake, see the *VICTORY Service Manual*, or contact an authorized VICTORY dealer for service.

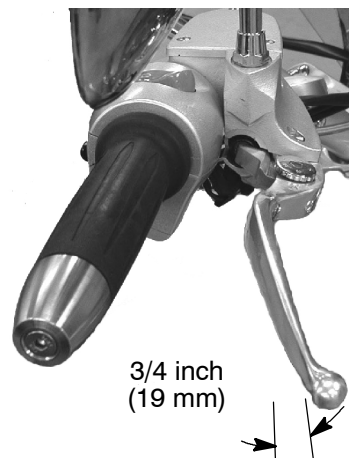

# MAINTENANCE

## Brakes

### Lubricate Front Brake Lever

1. Remove right side mirror.
2. Remove brake lever pivot nut (10mm wrench or socket) and pin (4mm hexagonal wrench). Note plunger direction of installation if removed. This is critical for proper brake function.
3. Remove any old grease and dirt from the brake lever and housing.
4. Lubricate the brake lever and lever pivot pin with VICTORY All Purpose Grease or equivalent.
5. Reinstall the brake lever and lever pivot pin.

**Torque the pivot pin to 52 in-lbs (6 Nm).**

6. Install the nut.

**Torque to 52 in-lbs (6 Nm).**

7. Check front brake lever movement (see above).
8. Install right side mirror and adjust.

## Brakes

### Check Front Brake Fluid Level

1. Position the motorcycle on level ground with the front wheel straight forward. Do not use the side stand. Position the handlebars so that the brake fluid reservoir is level.
2. View the brake fluid through the sight glass (1). The fluid should be clear and at a level in or above the sight glass. Add brake fluid if necessary.

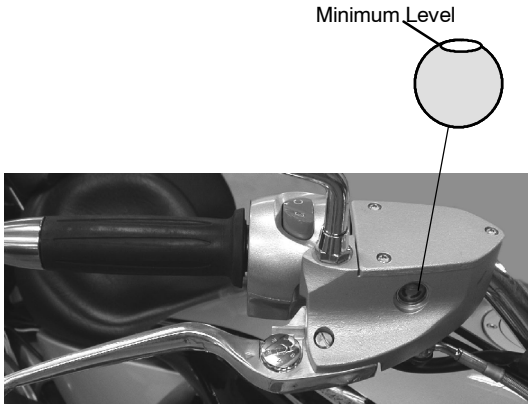



# MAINTENANCE

## Brakes

### Add Front Brake Fluid

#### WARNING

- **Do not operate the front brake while its reservoir cover is removed. Fluid could overflow from the reservoir and cause air to enter the fluid system. Air in the brake fluid system could cause the brakes to malfunction.**
  - **Use only DOT 4 brake fluid from a sealed, clean container. Using the wrong brake fluid, or allowing contaminants into the brake fluid system, can damage the system seals, resulting in the brakes malfunctioning.**
- 

1. Straddle the motorcycle and bring it to a vertical position. Turn the handlebars until the reservoir is horizontal.
2. Wipe the area around the reservoir cover with a clean cloth.
3. Wipe the brake fluid container with a clean cloth.
4. Remove the reservoir cover and gasket.

#### Caution

Brake fluid attacks painted surfaces and plastic parts. Always clean spilled brake fluid immediately with plenty of water and a mild detergent.

---

5. Carefully add enough brake fluid to bring the level just above the sight glass.
6. Reinstall the reservoir gasket and cover.

## Brakes

### Adjust Rear Brake Pedal

Press and release the rear brake pedal. It should move freely and smoothly and should return to its rest position quickly when you release it. You should feel a firm resistance in the pedal within the first 3/8 inch (8 mm) of pedal travel.

If the brake pedal travels too far before beginning to engage the brake, see the *VICTORY Service Manual*, or contact an authorized VICTORY dealer for service.

The brake pedal should be adjusted so that in the relaxed position, with the master cylinder piston positioned against internal stop, there is a 2-5 mm gap between the brake pedal stop and the foot peg mount. Make brake pedal adjustments as necessary.

1. Loosen the brake linkage rod locknut (1).
2. Turn the linkage rod in or out as necessary.
3. Tighten the linkage rod locknut.
4. Check the brake pedal adjustment.

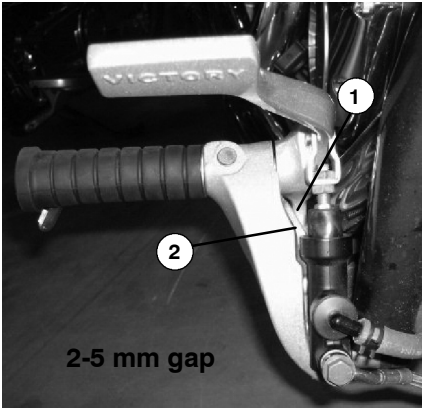

1. Brake pedal stop
2. Footpeg mount

# MAINTENANCE

## Brakes

### Check Rear Brake Fluid Level

1. To check the rear brake fluid level, remove right side cover. Straddle the motorcycle and bring it to a vertical position.
2. View the brake fluid through the reservoir. The fluid should be clear and at a level between minimum (MIN) and maximum (MAX) marks on the side of the reservoir. Add brake fluid if necessary.



1. Rear brake fluid reservoir
2. MAX brake fluid level mark
3. MIN brake fluid level mark

### Add Rear Brake Fluid

#### **WARNING**

- Do not operate the rear brake while its reservoir cover is removed. Fluid could overflow from the reservoir and cause air to enter the fluid system. Air in the brake fluid system could cause the brakes to malfunction.
  - Use only DOT 4 brake fluid from a sealed, clean container. Using the wrong brake fluid, or allowing contaminants into the brake fluid system, can damage the system resulting in brake malfunction.
-

## Brakes

### Add Rear Brake Fluid

1. Bring the motorcycle to a vertical position with an appropriate motorcycle lift or a block of wood or steel placed securely under the frame.
2. Remove the right side cover.
3. Wipe the area around the reservoir cover with a clean cloth.
4. Wipe the brake fluid container with a clean cloth.
5. Remove the reservoir cover and gasket.

### Caution

Brake fluid attacks painted surfaces and plastic parts. Always clean spilled brake fluid immediately with plenty of water and a mild detergent.

---

6. Carefully add enough brake fluid to bring the level between the minimum and maximum marks.
7. Reinstall the reservoir gasket and cover.
8. Reinstall the side cover.



1. Rear brake fluid reservoir
2. MAX brake fluid level mark
3. MIN brake fluid level mark

# MAINTENANCE

## Brakes

### Check Brake Pads

Inspect front (1) and rear (2) brake pad thickness. Replace brake pads when wear lines (3) are no longer visible, or when pad thickness reaches 1.5 mm.

The shielded pad must be installed on the non-piston side of the caliper. If the brake pads require replacement, see the *VICTORY Service Manual* or an authorized VICTORY dealer for assistance.

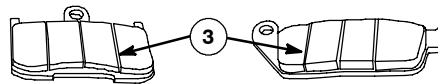
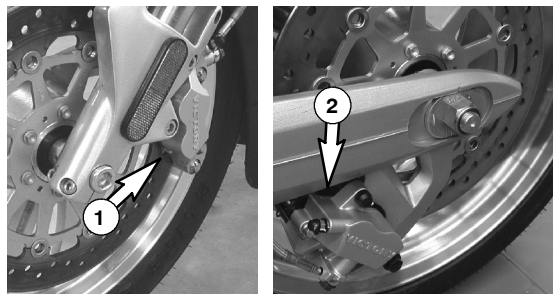

## Brakes

### Check Brake Disc

Visually inspect the brake disc for nicks, scratches, cracks, or other damage. Inspect the thickness of each brake disc in at least four points around the disc. Minimum thickness is stamped on the inner hub of the disc. If the front or rear disc has worn to the minimum thickness at the thinnest point, or if the disc is damaged, contact your VICTORY dealer for replacement.

### Check Brake Hoses and Connections

Inspect all brake hoses and connections for dampness or stains from leaking or dried fluid. Tighten any leaking connections and replace components as necessary. Refer to the Victory Service Manual for torque values of fasteners or contact your Victory dealer.

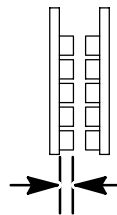

Replace pads if worn to less than 1.5 mm

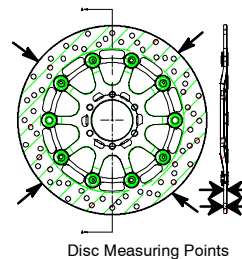

# MAINTENANCE

## Gear Shift Pedal

### Adjust Gear Shift Pedal Height

1. Loosen the gear shift linkage rod locknuts.
2. Turn the linkage rod in or out as necessary.
3. Tighten the linkage rod locknuts.
4. Check the gear shift pedal height.

### Caution

Do not remove and reposition the shift arm on the shift shaft to adjust gear shift pedal height. A  $90^\circ \pm 5^\circ$  angle between the shift arm and the linkage rod must be maintained to ensure correct shift linkage operation.

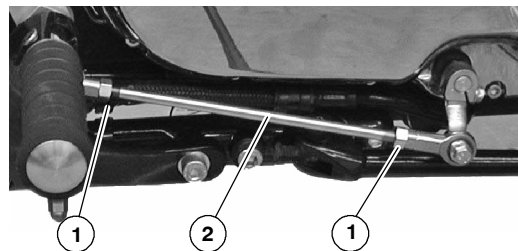
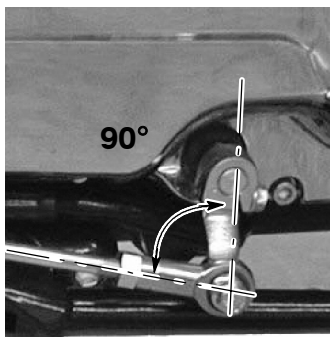

1. Shift Linkage Rod Lock Nut
2. Shift Linkage Rod

## Tires

### Check Tire Pressure

Normal riding warms the tires and increases the tire air pressure. For an accurate reading, check the tire pressure before you ride. Adjust tire pressure as required for the total weight of your intended load. You can also refer to the Tire Information decal located under the left side cover of the motorcycle.

### Tire Pressure Table

<b>VEGAS / VEGAS 8-BALL / VEGAS LOW</b>		
	Up to 200 lbs (91 kg) load	200-465 lbs (91-211 kg) load
FRONT: Dunlop Elite 3 90/90 21 54H	36 psi (248 KPa)	38 psi (262 KPa)
REAR: Dunlop D417 180/55-B18 74V	36 psi (248 KPa)	41 psi (283 KPa)

### Tire Pressure Table

<b>KINGPIN / KINGPIN TOUR / KINGPIN 8-BALL</b>		
	Up to 200 lbs (91 kg) load	200-465 lbs (91-211 kg) load
FRONT: Dunlop 491 Elite II 130/70-B18 63H	32 psi (221 KPa)	36 psi (248 KPa)
REAR: Dunlop D417 180/55-B18 74V	36 psi (248 KPa)	41 psi (283 KPa)



# MAINTENANCE

## Tires

### Check Tire Condition

Inspect the tire sidewalls, road contact surface, and tread base for cuts, punctures, and cracking. Replace damaged tires immediately (see your *VICTORY Service Manual* or an authorized VICTORY dealer).

### Check Tread Depth

Raised areas at the base of the tread, known as wear bars; act as easily visible tread depth indicators. When the road contact surface has worn to the top of the wear bars, replace the tire.

For more precise measurement, use a depth gauge or an accurate ruler to measure the depth of the center tire tread. Replace the tire if the tread depth is less than 1/16 inch (1.6 mm).



1. Tread Depth Gauge (Typical)

## Check or Replace Spark Plugs

The spark plugs must be removed from the engine to inspect them. Spark plugs with bright white deposits, sooty black deposits, or with damaged insulators or electrodes can indicate engine problems. If these conditions exist, or if the condition of one plug is markedly different from the other, see the *VICTORY Service Manual* or an authorized VICTORY dealer for assistance.

1. Make sure the engine is at room temperature.
2. Disconnect the spark plug wire by pulling upward on the spark plug boot.
3. To prevent any debris from entering the engine through the spark plug hole, use pressurized air to blow clean the area around each spark plug before removing it.

### **WARNING**

**Wear face protection when using pressurized air.**

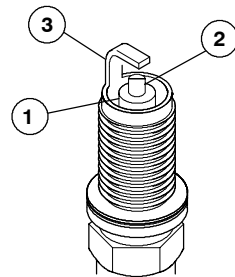

1. Insulator
2. Electrode Tip
3. Electrode Bridge

**Type: NGK DCPR6E**  
**Gap: .031-.035 inch (0.8-0.9mm)**

# MAINTENANCE

## Check or Replace Spark Plugs

4. Remove the spark plug from the cylinder head with a 5/8 inch spark plug socket.

Both spark plugs should have the same light or medium tan color deposits on the insulator around the electrode tip. The spark plug electrode tip and bridge should have sharp, square edges.

If spark plugs are in good condition and are not due for replacement, you can clean them with a non-metallic stiff bristle brush, set the gap and reinstall them.

Replace spark plugs at the recommended intervals. Always replace spark plugs in pairs.

5. Set the electrode gap with a spark plug gauge.

**Type:** NGK DCPR6E

**Gap:** .031-.035 inch (0.8-0.9 mm)

6. Clean the mating surface on the cylinder head and install the spark plug with a spark plug socket.

**Torque:** 10.8-14.5 ft-lbs (14.6-19.7 Nm)

7. Reconnect both spark plug wires.

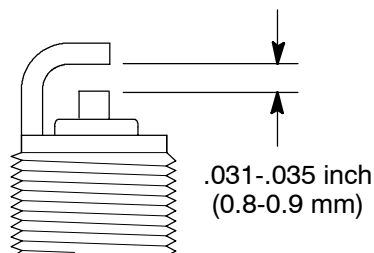

## Check Engine Compression

An accurate periodic engine compression check documents engine wear and condition. For engine compression check procedures and special tools required, see the *VICTORY Service Manual* or contact an authorized VICTORY dealer.

## Check Exhaust System

Check the exhaust system for stains from leaking exhaust gasses. Replace exhaust gaskets if necessary (see the *VICTORY Service Manual* or an authorized VICTORY dealer). Check all exhaust system fasteners.

1. Tighten exhaust header flange nuts.

**Torque: 12 ft-lbs (16 Nm)**

2. Tighten muffler mounting screws.

**Torque: 18 ft-lbs (24.5 Nm)**

3. Tighten support bracket nut.

**Torque: 35 ft-lbs (47.5 Nm)**

4. Tighten muffler clamps.

**Torque: 31 ft-lbs (42 Nm)**

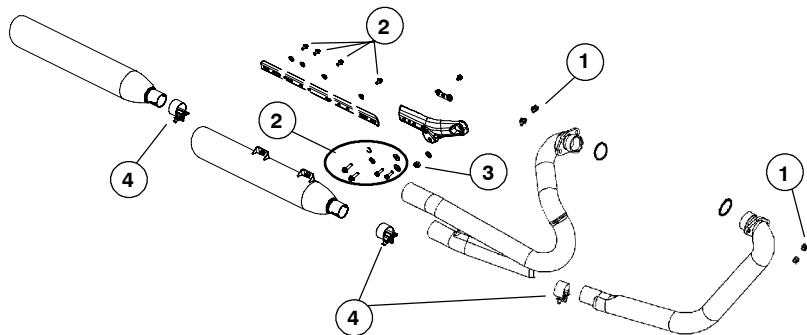

# MAINTENANCE

## Seat Removal and Installation

On passenger models, the passenger seat does not have to be removed for regular maintenance. If removal is desired, the passenger seat mounting screws are located on each side of the seat under the chrome covers.

### **WARNING**

**Always make sure the seats are securely fastened before riding the motorcycle. A loose seat could cause a sudden shift in riding position, causing loss of control.**

---

1. Remove the right and left side covers.
2. Remove the fuse box from the bracket (see page 27).
3. Remove the right seat screw. Remove the left seat screw.
4. Lift the rear of the seat and pull rearward and upward to remove it.

**NOTE:** To reinstall the seat, slide the tongue of the seat into the rubber mount at rear of fuel tank. Push down on the rear of the seat until the screw holes align.

5. Ensure the front seat mount is engaged in the front rubber mount, then install the screws and tighten securely.
6. Reinstall the fuse box and the left and right side covers.

## Battery

### **WARNING**

**The battery contains sulfuric acid, which can cause severe burns. Do not allow sulfuric acid to contact skin, eyes, or clothing.**

#### **Antidotes:**

- **External: Flush with water.**
  - **Internal: Drink large quantities of water or milk. Follow with milk of magnesia, beaten eggs, or vegetable oil. Call physician immediately.**
  - **Eyes: Flush with water for 15 minutes and get prompt medical attention.**
- 

The motorcycle uses a permanently sealed, maintenance-free battery. Do not remove the battery cap strip for any reason. Keep the battery connections clean and tight at all times.

**Notice** If your VICTORY motorcycle will not be used for a period of 6 weeks or longer, a maintenance charger should be connected to the battery. A fused maintenance charger connection is provided beneath the left side cover. The connector is designed for use with the VICTORY maintenance charger available at your authorized VICTORY dealer.

# MAINTENANCE

## Battery

### Battery Removal

1. Remove the left side cover and battery cover.
2. Disconnect the negative (-) battery cables (cable ends are exposed).
3. Disconnect the positive (+) cables (cable ends are covered with a red boot).

#### Caution

Disconnecting the positive cable first can produce an electric shock that could result in damage or injury.

---

4. Slide the battery out.



## Battery

### Battery Charging

#### **WARNING**

The battery may contain explosive gases.

- **Keep sparks, cigarettes, or any flame away from the battery.**
  - **Shield eyes and protect skin and clothing when handling or working near the battery.**
  - **Make sure ventilation is adequate when charging or using the battery in an enclosed space.**
  - **During charging, if the battery gets very hot to the touch, stop charging and let the battery cool down before continuing.**
- 

1. Clean oxidation from the battery posts and cable connectors with a wire brush. Wash the posts and cable connectors with a solution of 1 part baking soda to 16 parts water. Rinse with clean water and wipe dry. Apply a thin film of dielectric grease to the posts and cable connectors.
2. Following the charger manufacturer's instructions, use a battery charger designed for use with 12-volt batteries. The charger should have a maximum charging rate of 1.8 amps. Charge the battery for approximately 10 hours at a rate of 1.8 amps. If you use a taper or trickle charger, it will take longer to charge the battery.
3. After charging the battery, use a voltmeter to check the condition of the battery. Allow battery to sit 1-2 hours before checking the charge. The charge should be a minimum of 12.5 volts. Repeat the charging cycle if the charge is less than the minimum. Replace the battery if it fails to reach a 12.5 volt charge after two complete charging cycles.

### Accessory Battery Charger

An accessory maintenance charger (P/N 2859044) is available through your authorized Victory dealer.



# MAINTENANCE

## Battery

### Battery Installation

1. Before installing the battery, make sure it's fully charged and clean.
2. Slide the battery into position in the battery tray with positive (+) terminal to rear of motorcycle.
3. Connect the positive (+) battery cables, tighten securely and install the red boot.
4. Connect the negative (-) cables, tighten securely. Be sure cables have adequate side cover clearance.

#### Caution

- Connecting the negative cable first can produce an electric shock that could result in damage or injury.
  - Connecting the battery cables to the wrong terminals can severely damage the electrical system.
- 

5. Reinstall the battery cover.
6. Reinstall the left side cover.

## Fuses

### Caution

Use only recommended amperage fuses to avoid damage to the electrical system.

1. Remove the right side cover. Release the fuse box from the bracket by lifting the tab (1) and sliding the fuse box rearward (see diagram below right.)
2. Release the tabs on each side of the fuse box cover and remove the cover.
3. Remove the damaged fuse from the fuse box and seat the new fuse firmly in its place. A spare 15 amp fuse is located in the fuse box.
4. Reinstall the fuse box cover with the double cutout toward the front of the motorcycle. Reinstall the fuse box to the bracket.
5. Reinstall the side cover.

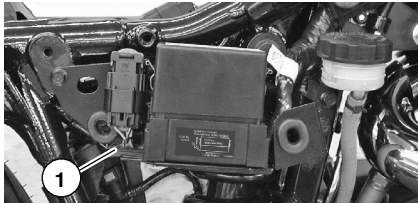

Fuse Application	Fuse Size
Engine / ECM	15 amp
Fuel Pump	10 amp
Headlamp / Brake Lamp	15 amp
Tail Lamp, Flashers, Indicator Lamp, Horn	15 amp
Ignition / Gauges	15 amp
Accessory Fuse (for emergency use) (Bike will operate without fuse)	15 amp

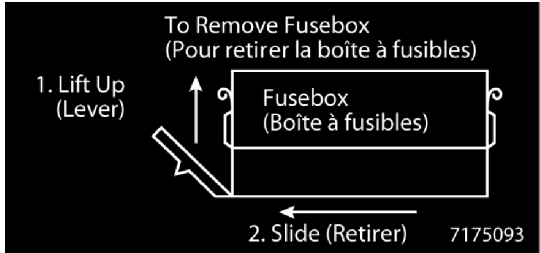

# MAINTENANCE

## Headlamp Adjustment

The headlamp high beam should shine straight ahead of the motorcycle. The top of headlamp high beam should be just below the center of the lamp at a distance of 25 feet (7.62 m). The low beam pattern spreads farther right of center than the high beam (U.S. & Canada).

1. Check and adjust the tire pressure (page 127).
2. Verify rear suspension ride height measurement is at specification (see page 101) before adjusting headlight.
3. Straddle the motorcycle in an upright position and sit in the operator's seat.
4. Set the ignition switch to the ON position and set the headlamp to High beam. Check the headlamp for correct aim.

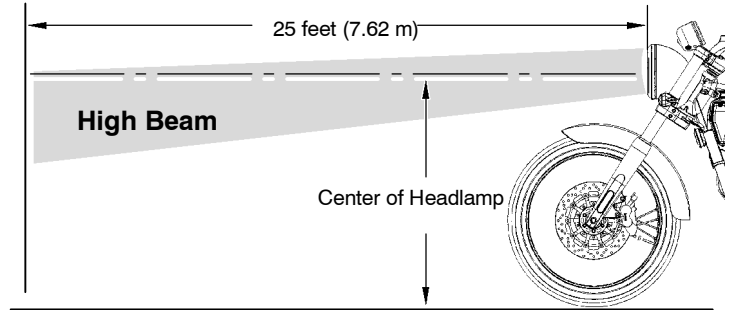

## Headlamp Adjustment

5. To adjust the headlamp vertically, loosen pivot nut (1) while holding bolt (2). Aim headlight and hold in position while tightening nut.

**Torque: 35 ft-lbs (47.5 Nm)**

6. To adjust the lamp horizontally, loosen the nut (3), aim headlight and hold in position while tightening nut.

**Torque: 28 ft-lbs (38 Nm)**

7. Verify proper headlamp adjustment and readjust if necessary.

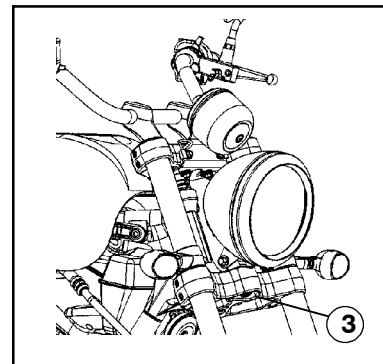
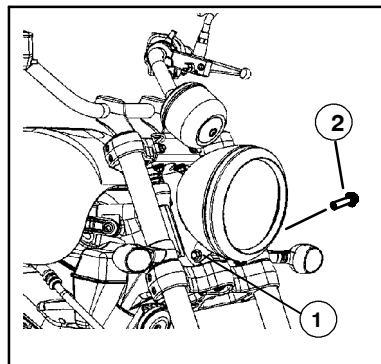

**(General Representation)**

# MAINTENANCE

## Sidestand

Straddle the motorcycle and bring it to a vertical position. Move the sidestand to its stored (up) position, then to its fully extended (down) position, and back again. It should move smoothly and quietly. When the sidestand is in its stored position, the sidestand return spring should hold the sidestand tightly against the motorcycle.

If the sidestand is bent, it should be replaced immediately.

### Caution

Do not try to straighten a bent sidestand. The sidestand will be weakened, and may not be able to support the motorcycle.

### Inspect Sidestand Pad

Straddle the motorcycle and bring it to a vertical position. Move the sidestand (1) to its stored (up) position, then to its fully extended (down) position and back again. It should move smoothly and quietly. When the sidestand is in its stored position, the sidestand return spring should hold the sidestand tightly against the motorcycle.

Check the condition of the sidestand rubber pad (2), and make sure it's firmly attached to the sidestand. Check the wear indicator (3) on the leading edge of the sidestand rubber pad. Replace the pad if worn beyond the WEAR LIMIT line on the pad.

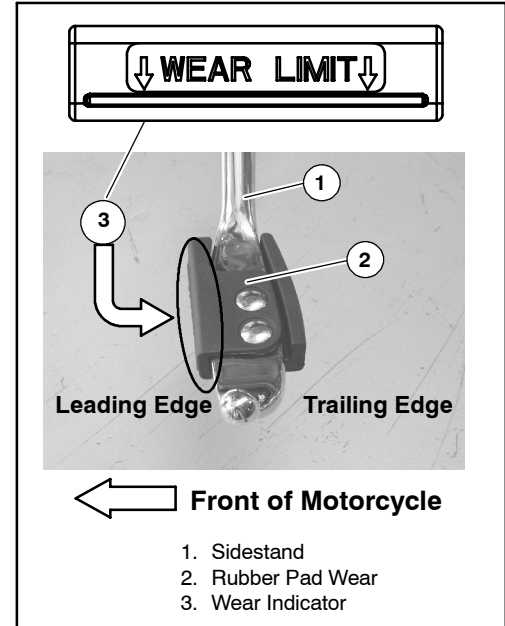

## Sidestand

### Sidestand Lubrication

1. Bring the motorcycle to a vertical position with an appropriate motorcycle lift or a block of wood or steel placed securely under the frame.
2. Move the sidestand to its stored (up) position.

### WARNING

**Wear face protection. The sidestand return spring is under tension and can injure your eyes and face when released.**

---

3. Hold the nut and remove the sidestand pivot bolt and sidestand return spring.
4. Wipe any old grease and dirt from the sidestand, frame, and pivot bolt.
5. Lubricate the sidestand, the pivot bolt, and the ends of spring with VICTORY All Purpose Grease or equivalent.
6. Reinstall the sidestand spring and place the sidestand on the mounting boss, with the stand in the stored (up) position.
7. Install the pivot bolt and tighten to specified torque while holding the nut.  
**Torque: 35 ft-lbs (47.5 Nm)**
8. Check to be sure the sidestand moves freely through its pivot range.

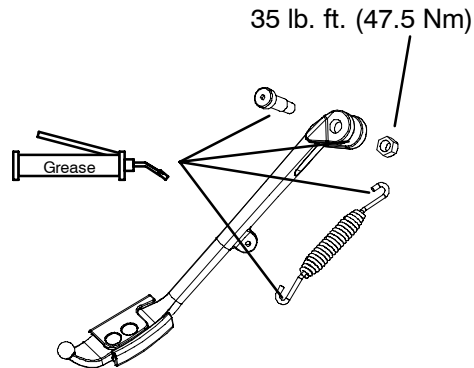

# MAINTENANCE

## Check Fasteners

Visually inspect the entire motorcycle chassis and engine for loose, damaged, or missing fasteners. Tighten loose fasteners to the proper torque (see the Specifications section of the *Owner's Manual*, or the *VICTORY Service Manual*). Replace stripped, damaged, or broken fasteners with genuine VICTORY fasteners of equal size and strength immediately.

## Universal Tool

The universal tool is located in a holder under the left side cover. The universal tool is a combination 6mm hexagonal wrench with a phillips screwdriver tip, and can be used to service the following items:

Oil Drain Plug

Handlebar Adjustment

Turn Signal Bulb

Air Filter

Passenger Seat

Indicator Bulbs

Headlight Bulb

Accessory Saddlebag, Windshield, and Driver's Backrest Fasteners

## Road Test

Before returning the motorcycle to regular use, road test it in a safe environment. Pay special attention to the proper fit and operation of all serviced components. Make any corrections or additional adjustments as necessary to ensure safe and enjoyable vehicle performance.

### **WARNING**

**Improperly installed or adjusted components can make the motorcycle unstable or hard to handle.**

**Improperly installed electrical components can cause engine or electrical system failure. In either case, damage or serious injury could result.**

---

**NOTES:**

---

---

---

---

---

---

---

---

---

---

---



# CLEANING

This section explains how to properly clean the various parts of your VICTORY motorcycle to keep it in good working order and appearance.

## General Cleaning

Clean your motorcycle regularly to protect it from corrosion and to keep it looking new. As you clean your motorcycle you perform a complete and thorough visual inspection that may reveal components in need of repair.

Clean the motorcycle if it is dusty or muddy, or if it has picked up foreign material such as road salt, insects, oil, tar, or tree sap. If you ride in an area with salty or polluted air, wash your motorcycle frequently. Proper cleaning requires washing and drying the motorcycle, and then applying wax, polish, and protectants to extend the service life and appearance of various components.

During cleaning you might use products that are potentially hazardous, such as polishing compounds. When using any of these products, follow the instructions and warnings on the product packaging.

Some foreign materials like insects, oil, tar, and tree sap can damage the motorcycle's fit and finish, and you should remove these materials as soon as possible. If normal washing does not remove these materials, you may need to use a special cleaner. Choose a cleaner designed for use on the type of surface you need to clean.

## Washing and Drying the Motorcycle

Before washing the motorcycle, always allow the engine to cool for at least 30 minutes. Do not spray water on a hot engine. Make sure the exhaust pipes have cooled. Cover each exhaust pipe opening with a plastic bag and attach the bag to the pipe with a strong rubber band. To prevent contamination from water, check that the spark plugs, spark plug wire caps, oil fill cap, and fuel caps are properly seated.

1. Park the motorcycle in the shade to prevent water spotting.
2. The engine cases are painted. If you choose to use a degreaser, follow the degreaser manufacturer's instructions.
3. Rinse off as much dirt and mud as possible with water running at low pressure.

### Caution

- Don't use high water pressure or high-pressure sprayers such as those found at car washes. Excessive water pressure may allow water to seep in and deteriorate wheel bearings, brake caliper assemblies, brake master cylinders, electrical connectors, steering head bearings, and transmission seals.
  - Electrical components may be damaged by contact with water. Do not spray or allow water to come into contact with electrical components or connectors.
- 
4. Wash the entire motorcycle using a soft cloth or sponge soaked in a solution of mild detergent and warm water, applying minimal pressure as you wash. Let the detergent do the cleaning, not the pressure you apply. Excessive washing pressure may cause dirt, sand, or other foreign materials on the motorcycle to scratch the finish. Keep the cloth or sponge clean by rinsing it frequently, and soak it in the detergent and water solution to provide plenty of soapy water for washing. A toothbrush or bottle brush can help you wash places that are difficult to reach with a cloth or a sponge.

# CLEANING

## Washing and Drying the Motorcycle

### Caution

Use as little water as possible when washing near the air cleaner or the exhaust pipe openings. An excessively wet air cleaner, or water in the exhaust pipes, may cause the engine to start and run poorly. Dry these components thoroughly before using the motorcycle.

---

5. Clean the front fork tubes thoroughly to reduce fork seal wear and leakage.
6. If insects, oil, tar, tree sap, or other foreign material is difficult to remove by applying gentle pressure using the warm water and mild detergent mixture, you may need to use a special cleaner. Choose a cleaner designed for use on the type of surface you plan to clean.
7. Rinse the motorcycle with water running at low pressure.
8. Remove the rubber bands and plastic bags from the exhaust pipes, and wipe the motorcycle dry with a soft cloth or chamois.
9. After washing the motorcycle, start the engine and let it idle for a few minutes. Make sure the brakes are functioning properly before riding.

### WARNING

**Excessively wet brake pads or discs may diminish braking effectiveness. Dry these components thoroughly before using the motorcycle.**

---

## Waxing, Polishing and Applying Protectants

(Items Other Than Windshields and Leather Saddlebags)

After washing and drying the motorcycle, you can help extend the life and appearance of its components by waxing painted surfaces, polishing chrome surfaces, and applying a protectant to exposed rubber, vinyl, and plastic parts. Avoid cleaning-waxing compounds, as they may contain abrasives that may damage the finish of painted parts. For chrome surfaces, use either a window-cleaning solution or a polish specifically designed for chrome. Follow manufacturer's instructions for proper application and use of wax, polish, or protectants.

After washing and drying the motorcycle, to help extend the life and appearance of its components:

- Wax painted surfaces. Avoid cleaning-waxing compounds, as they may contain abrasives that may damage the finish of painted surfaces.
- Polish chrome surfaces. Use either a window-cleaning solution or a polish specifically designed for chrome.
- Apply a protectant to exposed rubber, vinyl, and plastic components.

### **WARNING**

- **Do not use a protectant on the seats, footpegs, or handgrips that leaves a slippery coating after it dries. If these surfaces are slippery, you may have difficulty holding your position on the motorcycle while riding, which may cause loss of control.**
  - **Follow manufacturer's instructions and safety precautions on wax, polish, and protectant labels to prevent injury or damage.**
-

# CLEANING

## Windshield Care

If your motorcycle is equipped with an optional windshield:

Wash the windshield using a soft cloth or sponge soaked in a solution of mild detergent and warm water, applying minimal pressure as you wash. Let the detergent do the cleaning, not the pressure you apply. Excessive washing pressure may cause dirt, sand, or other foreign materials on the windshield to scratch it. Soak the cloth or sponge in the detergent and water solution frequently to provide plenty of soapy water for washing, and keep the cloth or sponge clean by rinsing it frequently.

- Minor scratches may be removed with a quality plastic polishing compound. Follow the manufacturer's instructions when using plastic polishing compounds.
- Insects, oil, tar, and tree sap may also damage the motorcycle's finish. If normal washing does not remove these materials, you may need to use a special cleaner. Choose a cleaner designed for use on clear plastic and follow the manufacturer's instructions when using special cleaners.

### Caution

Do not use glass cleaners, water or soil repellents, petroleum or alcohol based cleaners, as these products can damage the windshield.

---

## Leather Saddlebag Care

If your motorcycle is equipped with optional leather saddlebags:

Natural leather has “character.” Each piece used in the construction of these saddlebags is unique, and will settle into its own distinct form over time and miles. Mature leather is one-of-a-kind, and if properly cared for, gets better with age.

Caring for natural leather is similar to caring for your own skin. To prevent leather from becoming hard and dry, occasionally apply a leather conditioner. A good quality leather conditioner replaces the natural oils lost by repeated exposure to sun, wind and rain. Leather subject to drier climates will require more frequent conditioning.

To retain the beauty and character of your leather saddlebags, please follow these steps.

1. Vacuum or blow any loose dust or dirt from the saddlebag.
2. Use a good quality saddle soap and a sponge or soft cloth to clean the saddlebag. Always follow the manufacturer’s directions. Rinse the saddlebag with a clean wet cloth or sponge.
3. Once the leather is dry, treat it with a good quality leather conditioner. Always follow the manufacturer’s directions.
4. Allow the conditioner to dry, and wipe off any excess before using the saddlebag.

## Repairing Painted Surface Damage

After cleaning the motorcycle, inspect it for damage to the painted surfaces. If you discover chips or scratches in the paint, apply genuine VICTORY touch-up paint as soon as possible to prevent corrosion.

# STORAGE

If you will not operate the motorcycle for several months, such as during the winter, store the motorcycle to prevent damage to the fuel system and the battery and to protect components from corrosion or deterioration. During storage you might use products that are potentially hazardous; such as fuel stabilizer. When using any of these products, follow the instructions and warnings on the product packaging.

This section includes instructions for preparing the motorcycle for storage, maintaining it during storage and removing it from storage.

## Storage Area Preparation

Choose a dry, well-ventilated storage location, inside a garage or other structure if possible. The location should have a firm, flat surface and allow enough space for the motorcycle.

To best preserve tire condition:

- The storage area should have a relatively constant and moderate temperature.
- The motorcycle should not be near a radiator or other heat source, or any type of electric motor.
- The storage surface should be free of oil and gasoline.

## Clean and Protect the Motorcycle

To prepare the motorcycle for storage, begin by cleaning it as outlined beginning on page 144. Wax painted surfaces and polish chromed and other metal surfaces. Apply protectant to exposed rubber, vinyl, and plastic parts.

### Caution

Do not apply rubber protectant to the tire tread surfaces.

---

## Fuel Stabilizer

1. Using a mixture of fuel and the recommended amount of VICTORY Premium Carbon Clean Plus or other gasoline stabilizer, fill the fuel tank only to the top of the filler insert.
2. Ride the motorcycle or start and run the engine for 15 minutes in a well ventilated area to pass the stabilized fuel through entire fuel-injection system.

## Engine Component Protection

1. Change the engine oil (see page 88). You don't need to replace the oil filter at this time, but you must replace the oil filter when you remove the motorcycle from storage.

### Caution

Carbon deposits, normally suspended in engine oil that is in service, settle on internal engine components during storage. Settled carbon deposits can cause engine damage.

---



## **STORAGE**

### **Tire Inflation**

Inflate the tires to normal pressure (see page 127).

### **Battery Care**

1. Remove the battery (see page 134).
2. To clean oxidation from the battery posts and cable connectors, use a wire brush. Wash the posts and cable connectors with a solution of 1 part baking soda to 16 parts water. Rinse with clean water and wipe dry. Apply a thin film of dielectric grease (available from your VICTORY dealer) to the posts and cable connectors.
3. Clean the outside of the battery with a solution of mild detergent and warm water.
4. Store the battery in a dry location that maintains a temperature of 32° to 90°F (0° to 32°C).
5. While in storage, fully charge the battery once a month (see page 135).

### **Park and Cover the Motorcycle**

Park the motorcycle in its storage location. Cover the motorcycle with a genuine VICTORY motorcycle cover, or a cover made from a durable, breathable material designed for storage. Covering the motorcycle helps protect it from dust and other airborne materials. The cover must be of a breathable material to prevent moisture from building up on the motorcycle.

### **Maintenance During Storage**

Check and maintain normal tire pressure (page 127) and battery voltage during storage.

## Removal from Storage

1. Remove the cover and unlock the front forks (if locked with accessory lock).
2. Check the tire pressure (page 127) and inflate the tires if necessary.
3. Reinstall the battery (see page 136).
4. Wash and dry the entire motorcycle (see page 145).
5. Prior to starting the engine, change the engine oil and filter (see page 88, beginning with step 4).

### Caution

During storage, temperature and humidity changes can cause condensation to form in the crankcase and mix with engine oil. Running the engine with oil that contains condensation can cause engine damage.

---

6. Wax, polish or apply protectant to the appropriate motorcycle components (see page 147).
7. Perform the pre-operation check as outlined on page 50.
8. Road test the motorcycle before returning it to regular use (see page 142).

# WARRANTIES

## Motorcycle Noise Regulation

Tampering with noise control systems is prohibited. Federal law prohibits the following acts or causing thereof:

- The removal or rendering inoperative by any person other than for purposes of maintenance, repair, or replacement, of any device or element of design incorporated into any new vehicle for the purpose of noise control prior to its sale or delivery to the ultimate purchaser or while it is in use, or
  - The use of the vehicle after such device or element of design has been removed or rendered inoperative by any person.  
Among those acts presumed to constitute tampering are:
    - Removal or puncturing of the muffler, baffles, header pipes or any other component which conducts exhaust gases.
    - Removal or puncturing of any part of the intake system.
    - Lack of proper maintenance.
    - Replacing any moving part of the vehicle, or parts of the exhaust or intake system, with parts other than those specified by the manufacturer.
- This product should be checked for repair or replacement if the motorcycle noise has increased significantly through use. Otherwise, the owner may become subject to penalties under state and local ordinances.

## Noise Emission Warranty

VICTORY Motorcycle Division warrants that this exhaust system, at the time of sale, meets all applicable U.S. EPA Federal noise standards. This warranty extends to the first person who buys this exhaust system for purposes other than resale, and to all subsequent buyers. Warranty claims should be directed to: an authorized VICTORY dealer or VICTORY Motorcycle Division, Polaris Sales Inc., P.O. Box 47700, Hamel, MN 55340-9960

## Emissions Control System Warranty

VICTORY Motorcycles, Polaris Sales Inc. - Emission Control System Warranty Statement

### Your Warranty Rights and Obligations

The California Air Resources Board and VICTORY Motorcycle Division, Polaris Sales Inc. (hereinafter VICTORY) are pleased to explain the emission control system warranty on your 2008 or later VICTORY motorcycle. In California, new motor vehicles must be designed, built and equipped to meet the state's stringent anti-smog standards. VICTORY must warrant the emission control system on your motorcycle for the periods of time listed below provided there has been no abuse, neglect or improper maintenance of your motorcycle.

Your emission control system may include parts such as the fuel-injection system, the ignition system, catalytic converter and engine computer. Also included may be hoses, belts, connectors and other emission-related assemblies.

Where a warrantable condition exists, VICTORY will repair your motorcycle at no cost to you, including diagnosis, parts and labor.

### Manufacturer's Warranty Coverage

Class III motorcycles (280 cc and larger): for a period of use of five (5) years or 30,000 kilometers (18,641 miles), whichever first occurs.

If an emission-related part on your motorcycle is defective, the part will be repaired or replaced by VICTORY. This is your emission control system DEFECTS WARRANTY.

# WARRANTIES

## Owner's Warranty Responsibilities

As the motorcycle owner, you are responsible for the performance of the required maintenance listed in your owner's manual. VICTORY recommends that you retain all receipts covering maintenance on your motorcycle, but VICTORY cannot deny warranty solely for the lack of receipts or for your failure to ensure the performance of all scheduled maintenance.

You are responsible for presenting your motorcycle to a VICTORY dealer as soon as a problem exists. The warranty repairs should be completed in a reasonable amount of time, not to exceed 30 days.

As the motorcycle owner, you should be aware that VICTORY may deny your warranty coverage if your motorcycle or part has failed due to abuse, neglect, improper maintenance or unapproved modifications.

If you have any questions regarding your warranty rights and responsibilities, you should contact VICTORY Motorcycle Division, Polaris Sales Inc., P.O. Box 47700, Hamel, Minnesota 55340-9960, or the California Air Resources Board, P.O. Box 8001, 9528 Telstar Avenue, El Monte, CA 91734-8001.

VICTORY Motorcycle Division, Polaris Sales Inc. - Limited Warranty on Emission Control System

VICTORY Motorcycle Division, Polaris Sales Inc., (hereinafter VICTORY) warrants that each new 2008 and later VICTORY Motorcycle that includes as standard equipment a headlight, taillight and stoplight, and is street legal:

- A. is designed, built and equipped so as to conform at the time of initial retail purchases with all applicable regulations of the United States Environmental Protection Agency, and the California Air Resources Board; and
- B. is free from defects in material and workmanship which cause such motorcycle to fail to conform with applicable regulations of the United States Environmental Protection Agency or the California Air Resources Board for a period of use, depending on the engine displacement, of 12,000 kilometers (7,456 miles), if the motorcycle's engine displacement is less than 170 cubic centimeters; of 18,000 kilometers (11,185 miles), if the motorcycle's engine displacement is equal or greater than 170 cubic centimeters but less than 280 cubic centimeters; or of 30,000 kilometers (18,641 miles), if the motorcycle's engine displacement is 280 cubic centimeters or greater; or 5 (five) years from the date of initial retail delivery, whichever occurs first.

## I. Coverage

Warranty defects shall be remedied during customary business hours at any authorized VICTORY motorcycle dealer located within the United States of America in compliance with the Clean Air Act and applicable regulations of the United States Environmental Protection Agency and the California Air Resources Board. Any part or parts replaced under this warranty shall become the property of VICTORY.

In the State of California only, emission related warranted parts are specifically defined by the state's Emission Warranty Parts List. These warranted parts are: carburetor and internal parts; intake manifold; fuel tank; fuel injection system; spark advance mechanism; crankcase breather; air cutoff valves; fuel tank cap for evaporative emission controlled vehicles; oil filler cap; pressure control valve; fuel/vapor separator; canister; igniters; breaker governors; ignition coils; ignition wires; ignition points; condensers, and spark plugs if failure occurs prior to the first scheduled replacement; and hoses, clamps, fittings and tubing used directly in these parts. Since emission related parts may vary from model to model, certain models may not contain all of these parts and certain models may contain functionally equivalent parts.

In the State of California only, Emission Control System emergency repairs, as provided for in the California Administrative Code, may be performed by other than an authorized VICTORY dealer. An emergency situation occurs when an authorized VICTORY dealers is not reasonably available, a part is not available within 30 days, or a repair is not complete within 30 days. Any replacement part can be used in an emergency repair. VICTORY will reimburse the owner for expenses, including diagnosis, not to exceed VICTORY's suggested retail price for all warranted parts replaced and labor charges based on VICTORY's recommended time allowance for the warranty repair and the geographically appropriate hourly labor rate. The owner may be required to keep receipts and failed parts in order to receive compensation.

# WARRANTIES

## II. Limitations

This Emission Control System warranty shall not cover any of the following:

- A. Repair or replacement required as a result of:
  - (1) accident
  - (2) misuse
  - (3) repairs improperly performed or replacements improperly installed
  - (4) use of replacement parts or accessories not conforming to VICTORY specifications which adversely affect performance and/or
  - (5) use in competitive racing or related events.
- B. Inspections, replacement of parts, and other services and adjustments necessary for required maintenance
- C. Any motorcycle on which the odometer mileage has been changed so that actual mileage cannot be readily determined.

## III. Limited Liability

A. The liability of VICTORY under this Emission Control System Warranty is limited solely to the remedying of defects in material or workmanship by an authorized VICTORY motorcycle dealer at its place of business during customary business hours. This warranty does not cover inconvenience or loss of use of the motorcycle or transportation of the motorcycle to or from the VICTORY dealer. VICTORY SHALL NOT BE LIABLE FOR ANY OTHER EXPENSES, LOSS OR DAMAGE, WHETHER DIRECT, INCIDENTAL, CONSEQUENTIAL OR EXEMPLARY ARISING IN CONNECTION WITH THE SALE OR USE OF OR INABILITY TO USE THE VICTORY MOTORCYCLE FOR ANY PURPOSE. SOME STATES DO NOT ALLOW THE EXCLUSION OR LIMITATION OF ANY INCIDENTAL OR CONSEQUENTIAL DAMAGES, SO THE ABOVE LIMITATIONS MAY NOT APPLY TO YOU.

B. NO EXPRESS EMISSION CONTROL SYSTEM WARRANTY IS GIVEN BY VICTORY EXCEPT AS SPECIFICALLY SET FORTH HEREIN. ANY EMISSION CONTROL SYSTEM WARRANTY IMPLIED BY LAW, INCLUDING ANY WARRANTY OF MERCHANTABILITY OR FITNESS FOR A PARTICULAR PURPOSE, IS LIMITED TO THE EXPRESS EMISSION CONTROL SYSTEM WARRANTY TERMS STATED IN THIS WARRANTY. THE FOREGOING STATEMENTS OF WARRANTY ARE EXCLUSIVE AND IN LIEU OF ALL OTHER REMEDIES. SOME STATES DO NOT ALLOW LIMITATIONS ON HOW LONG AN IMPLIED WARRANTY LASTS SO THE ABOVE LIMITATIONS MAY NOT APPLY TO YOU.

C. No dealer is authorized to modify this VICTORY Limited Emission Control System Warranty.



# WARRANTIES

## IV. Legal Rights

THIS WARRANTY GIVES YOU SPECIFIC LEGAL RIGHTS, AND YOU MAY ALSO HAVE OTHER RIGHTS WHICH VARY FROM STATE TO STATE.

## V. This Warranty Is In Addition To The VICTORY Limited Motorcycle Warranty.

## VI. Additional Information.

Any replacement part that is equivalent in performance and durability may be used in the performance of any maintenance or repairs. However, VICTORY is not liable for these parts. The owner is responsible for the performance of all required maintenance. Such maintenance may be performed at a service establishment or by any individual. The warranty period begins on the date the motorcycle is delivered to an ultimate purchaser.

**VICTORY Motorcycle Division, Polaris Sales Inc.**  
**P.O. Box 47700**  
**Hamel, MN 55340-9960**  
**ATTN: Warranty Department**

## VICTORY Motorcycle Warranty Policy

### Limited Warranty

VICTORY Motorcycle Division, Polaris Sales Inc., P.O. Box 47700, Hamel, Minnesota 55340-9960, gives a ONE YEAR LIMITED WARRANTY on all components of the VICTORY Motorcycle against defects in material or workmanship. This warranty covers the parts and labor charges for repair or replacement of defective parts which are covered by this warranty. This warranty begins on the date of purchase. This warranty is transferrable to another consumer during the warranty period through a VICTORY Motorcycle dealer.

### Registration

At the time of sale, the Warranty Registration Form must be completed by your dealer and submitted to VICTORY Motorcycle Division, Polaris Sales Inc. within ten days. Upon receipt of this registration, VICTORY Motorcycle Division, Polaris Sales Inc. will record the registration for warranty. No verification of registration will be sent to the purchaser as the copy of the Warranty Registration Form will be the warranty entitlement. If you have not signed the original registration and received the “customer copy”, please contact your dealer immediately. **NO WARRANTY COVERAGE WILL BE ALLOWED UNLESS YOUR VICTORY MOTORCYCLE IS REGISTERED WITH VICTORY MOTORCYCLES DIVISION OF POLARIS SALES INC.**

Initial dealer preparation and set-up of your VICTORY Motorcycle is very important in ensuring trouble-free operation. Purchasing a motorcycle in the crate or without proper dealer set-up will void your warranty coverage.

# WARRANTIES

## Warranty Coverage And Exclusions:

### Limitations Of Warranties And Remedies

The warranty excludes any failures that are not caused by a defect in material or workmanship. This warranty does not cover accidental damage, normal wear and tear, abuse or improper handling. This warranty also does not cover any VICTORY Motorcycle that has been altered structurally, modified, neglected, improperly maintained, used for racing, or used for purposes other than for which it was manufactured, or for any damages which occur during trailer transit or as a result of unauthorized service or the use of unauthorized parts. In addition, this warranty does not cover physical damage to paint or finish, stress cracks, tearing or puncturing of upholstery material, corrosion, or defects in parts, components or VICTORY Motorcycle due to fire, explosions or any other cause beyond VICTORY Motorcycle Division, Polaris Sales Inc. control.

This warranty does not cover the use of unauthorized lubricants, chemicals, or fuels that are not compatible with the VICTORY Motorcycle.

The exclusive remedy for breach of this warranty shall be, at VICTORY Motorcycle Division, Polaris Sales Inc. exclusive option, repair or replacement of any defective materials, or components or products. THE REMEDIES SET FORTH IN THIS WARRANTY ARE THE ONLY REMEDIES AVAILABLE TO ANY PERSON FOR BREACH OF THIS WARRANTY. VICTORY MOTORCYCLES DIVISION OF POLARIS SALES INC. SHALL HAVE NO LIABILITY TO ANY PERSON FOR INCIDENTAL, CONSEQUENTIAL OR SPECIAL DAMAGES OF ANY DESCRIPTION, WHETHER ARISING OUT OF EXPRESS OR IMPLIED WARRANTY OR ANY OTHER CONTRACT, NEGLIGENCE, OR OTHER TORT OR OTHERWISE. Some states do not permit the exclusion or limitation of incidental or consequential damages or implied warranties, so the above limitations or exclusions may not apply to you if inconsistent with controlling state law.

# WARRANTIES

ALL IMPLIED WARRANTIES (INCLUDING BUT NOT LIMITED TO THE IMPLIED WARRANTIES OF MERCHANTABILITY AND FITNESS FOR A PARTICULAR PURPOSE) ARE LIMITED IN DURATION TO THE ABOVE ONE YEAR WARRANTY PERIOD. VICTORY MOTORCYCLES DIVISION OF POLARIS SALES INC. FURTHER DISCLAIMS ALL EXPRESS WARRANTIES NOT STATED IN THIS WARRANTY OTHER THAN EMISSIONS AND EXCISE WARRANTIES. Some states do not allow limitations on how long an implied warranty lasts, so the above limitation may not apply to you if inconsistent with controlling state law.

## **How To Obtain Warranty Service**

If your VICTORY Motorcycle requires warranty service, you must take it to a VICTORY Motorcycle Servicing Dealer. When requesting warranty service you must present your copy of the Warranty Registration form to the dealer. (THE COST OF TRANSPORTATION TO AND FROM THE DEALER IS YOUR RESPONSIBILITY). VICTORY Motorcycles division of Polaris Sales Inc. suggests that you use your original selling dealer; however, you may use any VICTORY Motorcycle Servicing Dealer to perform warranty service.

Please work with your dealer to resolve any warranty issues. Should your dealer require any additional assistance they will contact the appropriate person at VICTORY Motorcycles division of Polaris Sales Inc.

This warranty also gives you specific legal rights, and you may also have other rights which vary from state to state.

If any of the above terms are void because of state or federal law, all other warranty terms will remain in effect.

# SPECIFICATIONS

Model Year 2008	VEGAS / VEGAS 8-BALL / VEGAS LOW	KINGPIN / KINGPIN TOUR / KINGPIN 8-BALL
<b>Dimensions</b>		
Overall Length	96.3 in. (244.5 cm)	99.1 in. (251.9 cm)
Overall Width	38 in. (97 cm)	38 in. (97 cm)
Overall Height	50.75 in. (129 cm)	50.75 in. (129 cm)
Seat Height	26.5 in. (67.3 cm) 25.2 (64 cm) (VEGAS LOW)	26.5 in. (67.3 cm)
Wheelbase	66.5 in. (169 cm)	65.6 in. (167 cm)
Ground Clearance	5.8 in. (14.8 cm)	5.8 in. (14.8 cm)
Rake/Trail	33.1° / 5.28 in. (13.4 cm)	32.8° / 5.43 in. (13.8 cm)
<b>Weight</b>		
Dry Weight	658 lbs (298 kg) VEGAS 652 lbs (296 kg) VEGAS 8-BALL 651 lbs (295 kg) VEGAS LOW	676 lbs (307 kg) KINGPIN 741 lbs (336 kg) KINGPIN TOUR 670 lbs (304 kg) KINGPIN 8-BALL
Wet Weight	686 lbs (311 kg) VEGAS 680 lbs (308 kg) VEGAS 8-BALL 679 lbs (308 kg) VEGAS LOW	704 lbs (319 kg) KINGPIN 769 lbs (349 kg) KINGPIN TOUR 698 lbs (317 kg) KINGPIN 8-BALL
Gross Vehicle Weight Rating (GVWR)	1151 lbs (522 kg) VEGAS & 8-BALL 1134 lbs (514 kg) VEGAS LOW	1234 lbs (560 kg)
<b>Capacities</b>		
Engine Oil	5 qt. (4.75 l) Approximately 9 pt. (4.25 l) at oil change	5 qt. (4.75 l) Approximately 9 pt. (4.25 l) at oil change
Fuel	4.5 US gal. (17 l)	4.5 US gal. (17 l)
Fuel Reserve	.8 U.S. gal. (3.1 l)	.8 U.S. gal. (3.1 l)

**NOTE: Dimensions and specifications may vary with features, options and accessories.**

# SPECIFICATIONS

Model Year 2008	VEGAS / VEGAS 8-BALL / VEGAS LOW	KINGPIN / KINGPIN TOUR / KINGPIN 8-BALL
<b>Engine</b>		
Engine Type	Freedom <sup>®</sup> 100/6 V-Twin Freedom <sup>®</sup> 100/5 V-Twin (8-BALL)	Freedom <sup>®</sup> 100/6 V-Twin Freedom <sup>®</sup> 100/5 V-Twin (8-BALL)
Configuration	4 Stroke, 50° Transverse V-Twin	4 Stroke, 50° Transverse V-Twin
Displacement	100 cu in. (1639 cc)	100 cu in. (1639 cc)
Cooling System	Air & Oil	Air & Oil
Compression Ratio	8.7:1	8.7:1
Valve Train	4 Valves Per Cylinder With Hydraulic Lifters & Cam Chain Adjusters	4 Valves Per Cylinder With Hydraulic Lifters & Cam Chain Adjusters
Bore and Stroke	101 x 102 mm	101 x 102 mm
Fuel System / Throttle Body Bore	Electronic Fuel Injection / 45 mm	Electronic Fuel Injection / 45 mm
Exhaust System	Dual-Staggered	Dual-Staggered
Lubrication System	Wet Sump	Wet Sump
Spark Plug / Gap	NGK DCPR6E / .031-.035 inch (0.8-0.9 mm)	NGK DCPR6E / .031-.035 inch (0.8-0.9 mm)
<b>Chassis</b>		
Front Suspension Type/Travel	Telescopic Fork / 5.1 in. (13 cm)	Inverted Telescopic Fork / 5.1 in. (13 cm)
Rear Suspension Type/Travel	Single, Monotube Gas, Preload Adjustable / 3.9 in. (10 cm)	Single, Monotube Gas, Preload Adjustable / 3.9 in. (10 cm)
Swingarm	Forged and Cast Aluminum With Rising Rate Linkage	Forged and Cast Aluminum With Rising Rate Linkage
Front Brakes	Single 300 x 5 mm Floating Rotor 4 Piston Caliper	Single 300 x 5 mm Floating Rotor 4 Piston Caliper
Rear Brakes	Single 300 x 5 mm Floating Rotor 2 Piston Caliper	Single 300 x 5 mm Floating Rotor 2 Piston Caliper

**NOTE: Dimensions and specifications may vary with features, options and accessories.**

# SPECIFICATIONS

Model Year 2008	VEGAS / VEGAS 8-BALL / VEGAS LOW	KINGPIN / KINGPIN TOUR / KINGPIN 8-BALL
<b>Drive System</b>		
Final Drive Type	Carbon Fiber Reinforced Belt	Carbon Fiber Reinforced Belt
Transmission Type	6 Speed Overdrive, Constant Mesh 5 Speed, Constant Mesh (8-BALL)	6 speed Overdrive, Constant Mesh 5 Speed, Constant Mesh (8-BALL)
Primary Drive	Gear With Torque Compensator	Gear With Torque Compensator
Primary Reduction Ratio	1.5:1	1.5:1
Gear Shift Pattern	1 Down, 5 Up	1 Down, 5 Up
Internal Gear Ratios 1st	3.15:1	3.15:1
2nd	2.03:1	2.03:1
3rd	1.53:1	1.53:1
4th	1.24:1	1.24:1
5th	1:1	1:1
6th (Overdrive) 100/6 engines only	.84:1	.84:1
Final Drive Ratio	2.12:1	2.12:1
Clutch Type	Wet Multi-Plate; Diaphragm Spring	Wet Multi-Plate; Diaphragm Spring

**NOTE: Dimensions and specifications may vary with features, options and accessories.**

# SPECIFICATIONS

Model Year 2008	VEGAS / VEGAS 8-BALL / VEGAS LOW	KINGPIN / KINGPIN TOUR / KINGPIN 8-BALL
<b>Wheels and Tires</b>		
Front Wheel Type/Size	Cast or Billet 21 x 2.15	Cast or Billet 18 x 3.0
Rear Wheel Type Size	Cast or Billet 18 x 5.0	Cast or Billet 18 x 5.0
Front Tire Type/Size	Dunlop Elite 3 (90/90 - 21 54H)	Dunlop 491 Elite II (130/70 - B18 63H)
Rear Tire Type/Size	Dunlop D417 (180/55-B18 74V)	Dunlop D417 (180/55-B18 74V)
<b>Electrical</b>		
Alternator	38 Amp Max Output	38 Amp Max Output
Battery	12 Volts 18 Amp Hour	12 Volts 18 Amp Hour
<b>Lights and Fuses</b>		
Fuses Engine / ECM	15 amp	15 amp
Fuel Pump	10 amp	10 amp
Headlamp / Brake Lamp	15 amp	15 amp
Tail Lamp, Flashers, Indicator Lamps, Horn	15 amp	15 amp
Ignition / Gauges	15 amp	15 amp
Accessory	15 amp	15 amp
Bulbs Headlamp (International)	High: H7 / Low H11 (H4)	High: H7 / Low H11 (H4)
Taillight	Non-Serviceable LED	Non-Serviceable LED
Turn Signal	R10W	R10W
Indicator	2.3 Watt Wedge Base	2.3 Watt Wedge Base

**NOTE: Dimensions and specifications may vary with features, options and accessories.**



# **SPECIFICATIONS**

## **Fuel Specifications**

Use only unleaded gasoline, 92 pump octane minimum.

**DO NOT USE E85 GASOLINE OR GASOLINE CONTAINING METHANOL.**

Using E85 gasoline or gasoline/methanol blends can result in poor starting and driveability, and may damage critical fuel system components.

Gasoline containing up to 15% Methyl Tertiary Butyl Ether (MTBE) can be used.

Gasoline containing up to 10% Ethanol can be used.

Gasoline that has been Reformulated or Oxygenated can be used.

## **Engine Oil Specifications**

Polaris recommends the use of VICTORY Brand Synthetic Blend 20W-40 Motor Oil or an equivalent oil designed for use with wet clutches (such as those with a JASO MA rating).

## **Service Manual Available**

See your dealer to purchase a Victory Service Manual for your motorcycle (P/N 9921242).

# IDENTIFICATION NUMBERS

Record important numbers below.

**Vehicle Identification Number:** \_\_\_\_\_

(Located on right side of steering head, see page 37)

**Engine Identification Number:** \_\_\_\_\_

(Located on crankcase to right of oil filter, see page 38)

**Ignition Key Number:** \_\_\_\_\_

(Stamped on shaft of key, see page 38)

**Model Number:** \_\_\_\_\_

(Located on left side of steering head, see page 38)

# INDEX

## A

Accelerating .....	76
Accessory Battery Charger .....	135
Accessory Selection and Installation ..	20
<b>Adjustment</b>	
Clutch Lever Freeplay .....	112
Drive Belt Tension .....	96
Gear Shift Pedal Height .....	126
Headlamp Beam .....	138-139
Rear Brake Pedal .....	121
Shock Absorber Preload .....	100
Spark Plug Gap .....	129
Throttle Freeplay .....	110
Tire Pressure .....	127
Air Filter .....	91
Axle, Front .....	106
Axle, Rear .....	104

## B

Battery .....	133-136
Battery Charger .....	135
Battery Charging .....	135
Battery Installation .....	136
Battery Removal .....	134
Box Storage .....	17
Box, Top (Kingpin Tour) .....	17
Brake Disc Inspection .....	125
Brake Fluid .....	122
Brake Fluid Level .....	57, 59, 119, 122
Brake Fluid, Rear .....	123
Brake Hoses .....	125
Brake Lever .....	46
Brake Lever Lubrication .....	118
Brake Lever Movement .....	56, 117
Brake Pads .....	60, 124
Brake Pedal .....	47
Brake Pedal Adjustment .....	58, 121
Brakes .....	56-59, 117-125
Braking .....	77
Break-in Period .....	68-72

## C

Carrying a Passenger .....	11
Carrying Cargo .....	16
Check Engine Indicator .....	42
Clutch .....	62-63
Clutch Fluid Level .....	63
Clutch Freeplay .....	112
Clutch Lever .....	45
Clutch Lever and Cable .....	111
Clutch Lever Lubrication .....	115
Clutch, Hydraulic .....	113-114
Clutch, Mechanical .....	111-112
Component Identification .....	31-38
Components, Handlebar .....	31, 34
Components, Left Side .....	32, 35
Components, Right Side .....	33, 36
Compression, Engine .....	131
Control Cable Lubrication .....	116
Crankcase Ventilation Hose .....	107

# INDEX

## D

Defects .....	30
Drive Belt .....	65, 92-96
Drive Belt Condition .....	92
Drive Belt Tension .....	92-96

## E

Electrical Equipment .....	51-52
Emergency Flasher Switch .....	44
Emergency Flashers .....	52
Emissions Control System Warranty .	155
Engine Break-in Period .....	68-72
Engine Compression .....	131
Engine Identification Number .....	38
Engine Oil .....	88-90
Engine Oil Level .....	53, 90
Engine Oil Specifications .....	168
Engine Stop/Run Switch .....	46, 52
Evaporative Emission Control System (California models only) ...	54, 107
Exhaust .....	21
Exhaust System .....	131

## F

Fasteners .....	66, 142
Fork Oil .....	105
Forks .....	105
Front Axle .....	106
Front Brake Lever .....	46
Front Brake Lever Movement .....	56
Fuel .....	21
Fuel Cap .....	48
Fuel Components .....	54
Fuel Filter, Replacement .....	108
Fuel Hose .....	54
Fuel Hose, Rail and Connections	54, 107
Fuel Level .....	54
Fuel Specifications .....	168
Fuel Stabilizer .....	151
Fuel System .....	107-108
Fuel System Priming .....	71
Fuel Tank Removal/Installation ...	107
Fueling and Fill Height .....	70
Fuses .....	137

## G

Gasoline .....	21
Gear Shift Pedal .....	47, 126
Gross Vehicle Weight Rating (GVWR) .....	13-15
GVWR Loading Example .....	14-15

## H

Handlebar Components .....	31, 34
Handlebar Controls, Left .....	44-45
Handlebar Controls, Right .....	46
Hazardous Materials, Handling .....	81
Headlamp .....	51
Headlamp Adjustment .....	138-139
Headlamp High Beam Indicator .....	42
Headlamp High/Low Beam Switch ...	44
Horn .....	52
Horn Button .....	44
Hoses and Connections, Brakes .....	60

# INDEX

## I

Identification Numbers .....	169
Ignition Key .....	39
Ignition Key Number .....	38
Ignition Switch .....	39
Indicator Lights .....	42-43, 51
Initial Maintenance .....	82
Instrument Cluster .....	40

## K

Key Number, Ignition .....	38
----------------------------	----

## L

Left Side Views .....	32, 35
Loading Examples .....	14-15
Low Fuel Indicator .....	43
Low Oil Pressure Indicator .....	43

## M

Maintenance Interval Table .....	83-85
Maintenance Record .....	86-87
Maintenance, Safety .....	22-23
Modifications .....	18

## N

Neutral Indicator .....	42
Noise Emission Warranty .....	154
Noise Regulation .....	154

## O

Odometer .....	40
Oil .....	88-90
Oil Change .....	88-89
Oil Filter .....	88-89
Oil Filter Change .....	88-89
Oil Level .....	53, 89-90
Oil Specifications .....	168
Overdrive Indicator Lamp .....	41

## P

Park Position (P) .....	39
Parking the Motorcycle .....	18, 79-80
Periodic Maintenance Intervals .....	82
Priming the Fuel System .....	71
Protective Apparel .....	12

## R

### Rear Shock Absorber

Preload Specification .....	100
Preload Inspection .....	100
Ride Height Adjustment .....	102
Ride Height Measurement .....	101

Recommended Oil .....	89
Recommended Shift Points .....	75
Registration .....	161
Removal from Storage .....	153
Repairing Painted Surface Damage ..	149
Reporting Safety Defects .....	30

### Ride Height

Adjustment .....	102
Inspection .....	100
Specifications .....	100

Right Side Views .....	33, 36
Road Test .....	142

## S

Saddlebag Care, Leather .....	149
Saddlebags .....	17
Safe Riding Practices .....	6-12
Safety/Vehicle Information Labels ..	24-29
Safety Defects .....	30
Seat Removal/Installation .....	132
Service Manual Part Number .....	168
Shift Points .....	75
Shifting Gears .....	73-75
<b>Shock Absorber</b>	
Preload Specification .....	100
Preload Inspection .....	100
Ride Height Adjustment .....	102
Ride Height Measurement .....	101
Side Covers .....	48
Sidestand .....	49, 66, 140-141
Sidestand Lubrication .....	141
Sidestand Pad .....	140
Spark Plugs .....	129-130
Specifications .....	164-168
Speedometer .....	40
Starter Button .....	46
Starting the Engine .....	71-72
Steering .....	64, 105-106
Stop/Run Switch .....	46, 52
Stopping the Engine .....	78
Suspension, Front .....	64, 105-106
Suspension, Rear .....	65, 101-104
Swing Arm .....	104
Symbols and Terms .....	5

## T

Tachometer .....	41
Taillight / Brake Light .....	51
Test Drive .....	142
Throttle .....	109-110
Throttle Control Cables .....	61, 109
Throttle Control Grip .....	46, 61, 109
Throttle Freeplay Adjustment .....	110
Tire Condition .....	55, 128
Tire Pressure .....	55, 127
Tire Pressure Table .....	127
Tire Tread Depth .....	55, 128
Tires .....	55, 127-128
Tool, Universal .....	142
Top Box (Kingpin Tour) .....	17
Transporting the Motorcycle .....	19
Trip Odometer .....	40
Trunk (Top Box), Kingpin Tour .....	17
Turn Signal Indicators .....	43
Turn Signal Switch .....	45
Turn Signals .....	52

## U

Universal Tool .....	142
----------------------	-----

## V

Vehicle Identification Number .....	37
VICTORY Motorcycle Warranty ...	161
VIN .....	37

## W

Warranty, Owner's Responsibilities ..	156
Warranty Coverage and Exclusions ..	162
Warranty Policy .....	161
Washing/Drying the Motorcycle ..	145-146
Waxing/Polishing/Protectants .....	147
Wheel Alignment, Rear .....	97-99
Wheel, Rear .....	97-99
Windshield Care .....	148