

**Sportsman[®]
550 Touring**

**Sportsman[®]
850 Touring**

**Owner's Manual
for Maintenance and Safety**

Read this manual carefully. It contains important safety information.

This is an adult vehicle only.

Operation is prohibited for those under 16 years of age.

 WARNING

The engine exhaust from this product contains chemicals known to the State of California to cause cancer, birth defects or other reproductive harm.

A card containing important ATV safety information should be attached to the owner's manual on the next page. If you cannot locate this card, or if it has been removed, please call 1-800-342-3764 for assistance.



The text is printed on 100% recycled
with 40% post-consumer waste (PCW).

⚠️ WARNING

Improper vehicle use can result in SEVERE INJURY or DEATH.



**ALWAYS USE
AN APPROVED
HELMET AND
PROTECTIVE GEAR
FOR DRIVER
AND PASSENGER**



**NEVER USE
ON PUBLIC
ROADS**



**NEVER CARRY
MORE THAN
1 PASSENGER**



**NEVER USE
WITH DRUGS
OR ALCOHOL**

NEVER operate:

- without proper ATV training or instruction
- at speeds too fast for your skills or the conditions
- on public roads - a collision can occur with another vehicle
- with a passenger unless passenger seat is securely in place

THE OPERATOR MUST ALWAYS:

- use proper riding techniques to avoid vehicle overturns on hills and rough terrain and in turns
- avoid paved surfaces - pavement may seriously affect handling and control
- reduce speed and use extra caution at all times when carrying a passenger - dismount passenger when conditions require
- make sure passenger reads and understands this label and passenger safety label

**READ OWNER'S MANUAL.
FOLLOW ALL INSTRUCTIONS AND WARNINGS.**



POLARIS
The Way Out.®

For your nearest Polaris dealer,
call 1-800-POLARIS
or visit www.polarisindustries.com
Polaris Sales Inc., 2100 Hwy 55
Medina, MN 55340
Phone 1-888-704-5290
Part No. 9922730 Rev 01
Printed in USA



WELCOME

Thank you for purchasing a POLARIS vehicle, and welcome to our world-wide family of POLARIS owners. We proudly produce an exciting line of utility and recreational products.

- Snowmobiles
- All-terrain vehicles (ATVs)
- *RANGER*® utility vehicles
- Victory Motorcycles®
- Low emission vehicles (LEVs)

We believe POLARIS sets a standard of excellence for all utility and recreational vehicles manufactured in the world today. Many years of experience have gone into the engineering, design, and development of your POLARIS vehicle, making it the finest machine we've ever produced.

For safe and enjoyable operation of your vehicle, be sure to follow the instructions and recommendations in this owner's manual. Your manual contains instructions for minor maintenance, but information about major repairs is outlined in the POLARIS Service Manual and should be performed only by a factory certified Master Service Dealer® (MSD) technician.

Your POLARIS dealer knows your vehicle best and is interested in your total satisfaction. Be sure to return to your dealership for all of your service needs during, and after, the warranty period.

We also take great pride in our complete line of apparel, parts and accessories, available through our online store at www.purepolaris.com. Have your accessories and clothing delivered right to your door!



POLARIS
The Way Out.®

POLARIS, THE WAY OUT and SPORTSMAN are registered trademarks of POLARIS Industries Inc.

Copyright 2010 POLARIS Sales Inc. All information contained within this publication is based on the latest product information at the time of publication. Due to constant improvements in the design and quality of production components, some minor discrepancies may result between the actual vehicle and the information presented in this publication. Depictions and/or procedures in this publication are intended for reference use only. No liability can be accepted for omissions or inaccuracies. Any reprinting or reuse of the depictions and/or procedures contained within, whether whole or in part, is expressly prohibited.

The original instructions for this vehicle are in English. Other languages are provided as translations of the original instructions.

Printed in U.S.A.

2011 SPORTSMAN 550/850 Touring Owner's Manual

P/N 9922730

TABLE OF CONTENTS

Introduction	4
Safety	7
Features and Controls	26
Operation	52
Emission Control Systems	75
Maintenance	76
Troubleshooting	127
POLARIS Products	131
Specifications	132
Declaration of Conformity	136
Warranty	137
Maintenance Log	144
Index	146

INTRODUCTION

The following signal words and symbols appear throughout this manual and on your vehicle. Your safety is involved when these words and symbols are used. Become familiar with their meanings before reading the manual.



The safety alert symbol indicates a potential personal injury hazard.

WARNING

A **WARNING** indicates a hazardous situation which, if not avoided, may result in death or serious injury.

CAUTION

A **CAUTION** indicates a hazardous situation which, if not avoided, may result in minor or moderate injury.

NOTICE

A **NOTICE** indicates a situation that may result in property damage.



The Prohibition Safety Sign indicates an action **NOT** to take in order to avoid a hazard.



The Mandatory Action Sign indicates an action that **NEEDS** to be taken to avoid a hazard.

INTRODUCTION

WARNING

Failure to heed the warnings and safety precautions contained in this manual can result in severe injury or death. A POLARIS ATV is not a toy and can be hazardous to operate. This vehicle handles differently than other vehicles, such as motorcycles and cars. A collision or rollover can occur quickly, even during routine maneuvers like turning, or driving on hills or over obstacles, if you fail to take proper precautions.

- Read this owner's manual. Understand all safety warnings, precautions and operating procedures before operating a POLARIS ATV. Keep this manual with the ATV.
- Never operate an ATV without proper instruction. Take a training course.
- This vehicle is an **ADULT VEHICLE ONLY**. Operation is prohibited for anyone under 16 years of age.
- Never permit a guest to operate the ATV unless the guest has read this manual and all product labels and has completed a certified safety training course.

INTRODUCTION

Vehicle Identification Numbers

Record your vehicle's identification numbers and key number in the spaces provided. Remove the spare key and store it in a safe place. An ignition key can be duplicated only by ordering a POLARIS key blank (using your key number) and mating it with one of your existing keys. The ignition switch must be replaced if all keys are lost.

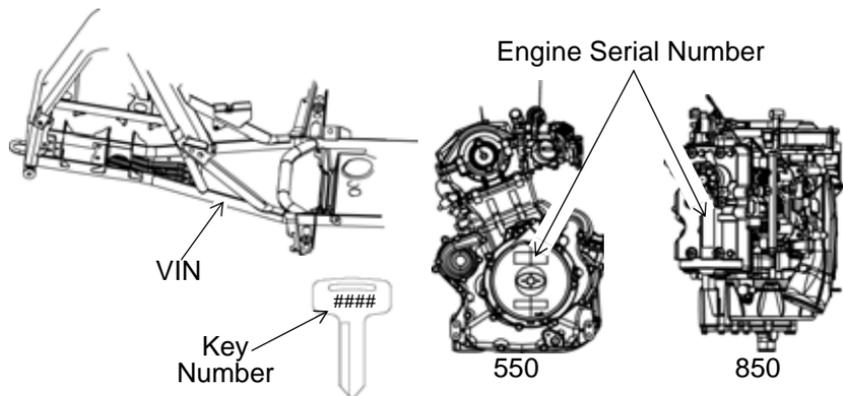

Vehicle Model Number: _____

Frame VIN: _____

Engine Serial Number: _____

Key Number: _____

Safety Training

ATV safety training is a top priority for POLARIS. POLARIS strongly encourages you and any family members who will be riding the ATV to take a training course.

If you purchased a new POLARIS ATV in the United States, your dealer provided information about the authorized ATV *RiderCourse*sm that is available to you and your eligible family members. This training is included in the purchase price of your ATV. You were also provided with printed materials that explain safe operating procedures. You should review this information on a regular basis.

If you purchased a used POLARIS ATV in the United States, you can enroll in the ATV *RiderCourse*sm for a fee. Call ATV Enrollment Express at (800) 887-2887 or visit www.atvsafety.org.

If you purchased a POLARIS ATV outside the United States, please contact your dealer or local law enforcement agencies for information about safety training.

A POLARIS ATV is an off-road vehicle. Familiarize yourself with all laws and regulations concerning the operation of this vehicle in your area.

We strongly advise you to strictly follow the recommended maintenance program outlined in your owner's manual. This preventive maintenance program is designed to ensure that all critical components on your vehicle are thoroughly inspected at specific intervals.

FOR MORE INFORMATION ABOUT ATV SAFETY in the United States, call the Consumer Product Safety Commission at 1-800-638-2772, or visit www.cpsc.gov, visit www.atvsafety.org, or call POLARIS at 1-800-342-3764.

SAFETY

Safe Riding Gear

Always wear appropriate clothing when riding an ATV. Wear protective clothing for comfort and to reduce the chance of injury.

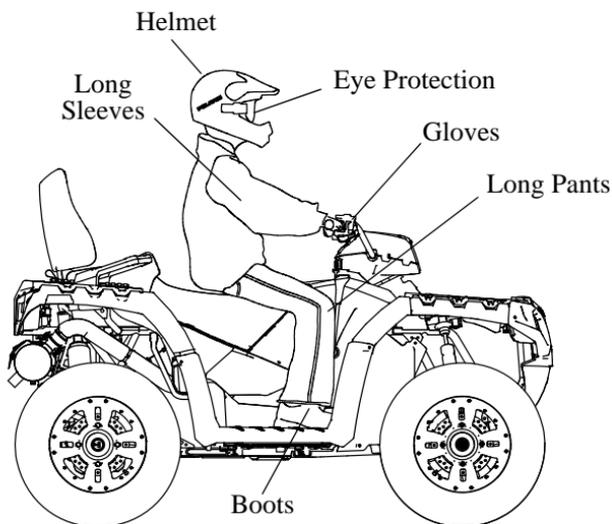

Helmet

Wearing a helmet can prevent a severe head injury. Whenever riding a POLARIS vehicle, always wear a helmet that meets or exceeds established safety standards.

Approved helmets in the USA and Canada bear a U.S. Department of Transportation (DOT) label.

Approved helmets in Europe, Asia and Oceania bear the ECE 22.05 label. The ECE mark consists of a circle surrounding the letter E, followed by the distinguishing number of the country which has granted approval. The approval number and serial number will also be displayed on the label.

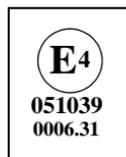

Safe Riding Gear

Eye Protection

Do not depend on eyeglasses or sunglasses for eye protection. Whenever riding a POLARIS vehicle, always wear shatterproof goggles or use a shatterproof helmet face shield. POLARIS recommends wearing approved Personal Protective Equipment (PPE) bearing markings such as VESC 8, V-8, Z87.1, or CE. Make sure protective eye wear is kept clean.

Gloves

Off-road style gloves with knuckle pads are the best for comfort and protection.

Boots

The best footwear is a pair of sturdy over-the-calf boots with low heels.

Clothing

Always wear long sleeves and long pants to protect arms and legs. Riding pants with kneepads and a jersey with shoulder pads provide the best protection.

Equipment Modifications

We strongly recommend that consumers do not install on a POLARIS ATV any equipment that may increase the speed or power of the vehicle, or make any other modifications to the vehicle for these purposes.

The warranty on your POLARIS ATV is terminated if any equipment has been added to the vehicle, or if any modifications have been made to the vehicle, that increase its speed or power.

The addition of certain accessories, including (but not limited to) mowers, blades, tires, sprayers, or large racks, may change the handling characteristics of the vehicle. Use only POLARIS-approved accessories, and familiarize yourself with their function and effect on the vehicle.

SAFETY

Safety Warnings

⚠ WARNING

Failure to operate the ATV properly can result in a collision, loss of control, accident or overturn, which may result in serious injury or death. Heed all safety warnings outlined in this section of the owner's manual. See the OPERATION section of the owner's manual for proper operating procedures.

Operating Without Instruction

Operating this ATV without proper instruction increases the risk of an accident. The operator must understand how to operate the ATV properly in different situations and on different types of terrain.

Beginning and inexperienced operators should complete the recommended safety training before operating this vehicle. See page 7.

Never permit a guest to operate the ATV unless the guest has read this manual and all product labels and has completed a certified safety training course.

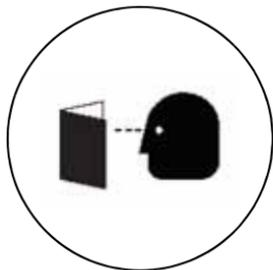

Age Restrictions

This vehicle is an **ADULT VEHICLE ONLY**. Operation is prohibited for anyone under 16 years of age. Never allow anyone under 12 years of age to ride as a passenger on this 2-up ATV.

Even though a child may be within the recommended age group for operating some ATVs, he/she may not have the skills, abilities, or judgment needed to operate or ride on this ATV safely and could be susceptible to accident or injury.

Safety Warnings

Handling Gasoline

Gasoline is highly flammable and explosive under certain conditions.

- Always exercise extreme caution whenever handling gasoline.
- Always refuel with the engine stopped, and outdoors or in a well ventilated area.
- Do not smoke or allow open flames or sparks in or near the area where refueling is performed or where gasoline is stored.
- Do not overfill the tank. Do not fill the tank neck.
- If gasoline spills on your skin or clothing, immediately wash it off with soap and water and change clothing.

Exposure to Exhaust

Engine exhaust fumes are poisonous and can cause loss of consciousness or death in a short time. Never start the engine or let it run in an enclosed area.

The engine exhaust from this product contains chemicals known to cause cancer, birth defects or other reproductive harm. Operate this vehicle only outdoors or in well-ventilated areas.

Failure to Inspect Before Operating

Failure to inspect and verify that the ATV is in safe operating condition before operating increases the risk of an accident.

Always inspect the ATV before each use to make sure it's in safe operating condition.

Always follow all inspection and maintenance procedures and schedules described in the owner's manual.

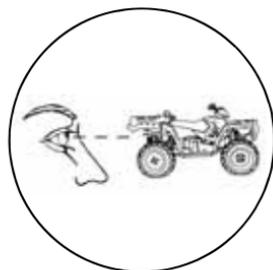

SAFETY

Safety Warnings

Protective Apparel

Riding in this vehicle without wearing an approved helmet and protective eyewear increases the risk of a serious injuries in the event of an accident.

Operator and passenger must always wear an approved helmet that fits properly and eye protection (goggles or face shield).



Carrying a Passenger

Do not carry a passenger until you have at least two hours of driving experience with this vehicle.

Carrying More Than One Passenger

Carrying more than one passenger greatly reduces the operator's ability to balance and control the ATV, which may result in an accident or overturn.

Never carry more than one passenger on this 2-up ATV.



Using Alcohol or Drugs

Operating the ATV after consuming alcohol or drugs could adversely affect operator judgment, reaction time, balance and perception.

Never consume alcohol or drugs before or while operating an ATV.



Safety Warnings

Operating on Pavement

Operating an ATV on paved surfaces (including sidewalks, paths, parking lots and driveways) may adversely affect the handling of the ATV and could result in loss of control and accident or overturn.

Avoid operating the ATV on pavement. ATV tires are designed for off-road use. If it's unavoidable, travel slowly and avoid sudden turns or stops.



Operating on Public Roads

Operating this ATV on public streets, roads or highways could result in a collision with another vehicle.

Never operate the ATV on any public street, road or highway, including dirt and gravel roads. In many states it's unlawful to operate ATVs on public streets, roads and highways.



Operating at Excessive Speeds

Operating the ATV at excessive speeds increases the operator's risk of losing control.

Never operate at excessive speeds. Travel at speeds appropriate for your skills, your passenger's skills, and operating conditions.



SAFETY

Safety Warnings

Physical Control of the ATV

Removing even one hand or foot can reduce ability to control the vehicle or could cause loss of balance and ejection from the ATV.

If a person's feet are not firmly planted on the footrests, they could come into contact with the wheels or other moving parts and lead to accident or injury.

Always keep both hands on the handlebars and both feet on the footrests of the ATV during operation. A passenger should always be seated in the passenger seat with both feet on the footrests and both hands on the passenger grab handles at all times. The passenger should never hold on to the operator.



Turning Improperly

Turning improperly could cause loss of traction, loss of control, accident or overturn.

Always follow proper procedures for turning as described in the owner's manual.

Practice turning at slow speeds before attempting to turn at faster speeds.

Never turn at excessive speed.



Jumps and Stunts

Attempting wheelies, jumps and other stunts increases the risk of an accident or overturn.

Never attempt wheelies, jumps, or other stunts. Avoid exhibition driving.



Safety Warnings

Improper Hill Climbing

Improper hill climbing could cause loss of control or overturn. Always follow proper procedures for climbing hills as described in the owner's manual. See page 63. Always move the 4X4 switch to ADC 4X4 before ascending or descending a hill.

Descending Hills Improperly

Improperly descending a hill could cause loss of control or overturn.

- Always follow proper procedures for traveling down hills as described in the owner's manual. See page 65.
- Always descend a hill with the transmission in forward gear. Do not descend a hill with the transmission in neutral. Always move the 4X4 switch to ADC 4X4 before ascending or descending a hill. See page 39.
- Always check the terrain carefully before descending a hill.
- Shift your weight rearward.
- Never travel down a hill at high speed.
- Avoid traveling down a hill at an angle, which would cause the vehicle to lean sharply to one side. Travel straight down the hill when possible.

Crossing Hillsides

Driving on a sidehill is not recommended. Improper procedure could cause loss of control or overturn. Avoid crossing the side of any hill unless absolutely necessary.

If crossing a hillside is unavoidable, always follow proper procedures as described in the owner's manual. See page 64.

Never attempt to turn the ATV around on any hill until you've mastered the turning technique (on level ground) as described in the owner's manual. See page 66.



SAFETY

Safety Warnings

Stalling While Climbing a Hill

Stalling, rolling backwards or improperly dismounting while climbing a hill could cause an overturn.

- Always maintain a steady speed when climbing a hill.
- Always move the 4X4 switch to ADC 4X4 before ascending or descending a hill. See page 39.

If all forward speed is lost:

- Lean forward to keep body weight uphill. A passenger should also lean uphill.
- Apply the single lever brakes.
- Lock the parking brake when fully stopped.
- Dismount on the uphill side of the vehicle, or on the left if the vehicle is pointing straight uphill. Have a passenger dismount first, then the operator may dismount.
- Turn the ATV around and remount, following the procedure described in the owner's manual. See page 66.

If the ATV begins rolling backwards:

- Keep operator and passenger body weight uphill.
- Never apply engine power.
- Never apply the rear brake while rolling backwards.
- Apply the single-lever brake gradually.
- When fully stopped, apply the foot brake as well, and then lock the parking brake.
- Dismount on the uphill side of the vehicle, or on the left if the vehicle is pointing straight uphill. Have a passenger dismount first, then the operator may dismount.
- Turn the ATV around and remount, following the procedure described in the owner's manual. See page 66.

Operating on Steep Hills

Operating on excessively steep hills could cause an overturn.

Never operate on hills too steep for the ATV or for your abilities. Never operate the ATV on hills steeper than 15 degrees.



Safety Warnings

Operating on Slippery Terrain

Failure to use extra caution when operating on excessively rough, slippery or loose terrain could cause loss of traction, loss of control, accident or overturn.

Do not operate on excessively rough, slippery or loose terrain until you've learned and practiced the skills necessary to control the ATV on such terrain.

Always use extra caution on rough, slippery or loose terrain.



Operating in Unfamiliar Terrain

Failure to use extra caution when operating on unfamiliar terrain could result in an accident or overturn.

Unfamiliar terrain may contain hidden rocks, bumps, or holes that could cause loss of control or overturn.

Travel slowly and use extra caution when operating on unfamiliar terrain. Always be alert to changing terrain conditions.



Operating Improperly in Reverse

Improperly operating in reverse could result in a collision with an obstacle or person. Always follow proper operating procedures as outlined in this manual. See page 70.

Before shifting into reverse gear, always check for obstacles or people behind the ATV. When it's safe to proceed, back slowly.



SAFETY

Safety Warnings

Improper Tire Maintenance

Operating this ATV with improper tires or with improper or uneven tire pressure could cause loss of control or accident.

Always use the size and type of tires specified for your ATV.

Always maintain proper tire pressure as described in the owner's manual and on safety labels.



Operating Over Obstacles

Improperly operating over obstacles could cause loss of control or overturn.

Before operating in a new area, check for obstacles. Avoid operating over large obstacles such as rocks and fallen trees. If unavoidable, use extreme caution and always follow proper operating procedures as outlined in this manual. See page 69.



Skidding or Sliding

Skidding or sliding can cause loss of control or overturn (if tires regain traction unexpectedly).

On slippery surfaces such as ice or loose gravel, travel slowly and use extra caution to reduce the chance of skidding or sliding. Do not operate on excessively slippery surfaces.



Safety Warnings

Operating Through Deep Water

Operating the ATV through deep or fast-flowing water could cause the tires to float, causing loss of control or overturn.

Avoid operating the ATV through deep or fast-flowing water. If it's unavoidable to enter water that exceeds the recommended maximum depth (see page 68):

- Travel slowly.
- Balance your weight carefully.
- Avoid sudden movements.
- Maintain a slow and steady forward motion. Do not make sudden turns or stops, and do not make sudden throttle changes.

Wet brakes may have reduced stopping ability. After leaving water, test the brakes. Apply them lightly several times while driving. The friction will help dry out the pads.



Improper Cargo Loading

Overloading the ATV or carrying/towing cargo improperly may cause changes in handling, which could cause loss of control or an accident.

- Never exceed the stated load capacity for this ATV.
- Cargo should be properly distributed and securely attached.
- Reduce speed when carrying cargo or pulling a trailer. Allow a greater distance for braking.
- Always follow the instructions in the owner's manual for carrying cargo or pulling a trailer. See pages 72-74.
- Always follow the instructions in the owner's manual for operating with a passenger. See page 60.



SAFETY

Safety Warnings

Operating on Frozen Bodies of Water

Operating on frozen bodies of water may result in serious injury or death if the ATV and/or riders fall through the ice.

Never operate the ATV on a frozen body of water unless you have independently verified that the ice is sufficiently thick to support the weight and moving force of the ATV, you and your cargo, together with any other vehicles in your party. Variances in snow depth and/or water currents may result in uneven ice thickness. Always check with local authorities and residents to confirm ice conditions and thickness over your entire route. ATV operators assume all risk associated with ice conditions on frozen bodies of water.



Poor Visibility

Operating the ATV in darkness or inclement weather could result in a collision or accident, especially if operating on a road or street. This ATV is not equipped with highway-approved lights. Operate this vehicle off-road only. Use caution and drive at reduced speeds in conditions of reduced visibility such as fog, rain and darkness. Clean headlights frequently and replace burned out headlamps promptly.

Safety Warnings

Operating a Damaged ATV

Operating a damaged ATV can result in an accident. After any overturn or accident, have a qualified service dealer inspect the entire machine for possible damage, including (but not limited to) brakes, throttle and steering systems.

Physical Skills

Safe operation of this rider-active vehicle requires good judgement and physical skills. Persons with cognitive or physical disabilities who operate this vehicle have an increased risk of overturn and loss of control. Never secure a passenger to the vehicle or to the operator with a belt, rope or similar device.

Hot Exhaust Systems

Exhaust system components are very hot during and after use of the vehicle. Hot components can cause burns and fire. Do not touch hot exhaust system components. Always keep combustible materials away from the exhaust system. Use caution when traveling through tall grass, especially dry grass.

Unauthorized Use of the ATV

Leaving the keys in the ignition can lead to unauthorized use of the vehicle, which could result in an accident or overturn. Always remove the ignition key when the vehicle is not in use.

SAFETY

Safety Labels and Locations

Warning labels have been placed on the vehicle for your protection. Read and follow the instructions on each label carefully. If any of the labels shown in this manual differ from the labels on your vehicle, always read and follow the instructions of the labels on the vehicle.

If an informational or graphic label becomes illegible or comes off, contact your POLARIS dealer to purchase a replacement. Replacement *safety* labels are provided by POLARIS at no charge. The part number is printed on the label.

Reverse Override Warning/AWD Caution

WARNING

Improper use of override button can lead to loss of control resulting in severe injury or death. Do not activate override while throttle is engaged. Always apply throttle gradually while in reverse.

CAUTION

Do not push switch to engage 4x4 (AWD) if the rear wheels are spinning. This may cause severe drive shaft and clutch damage.

7175512

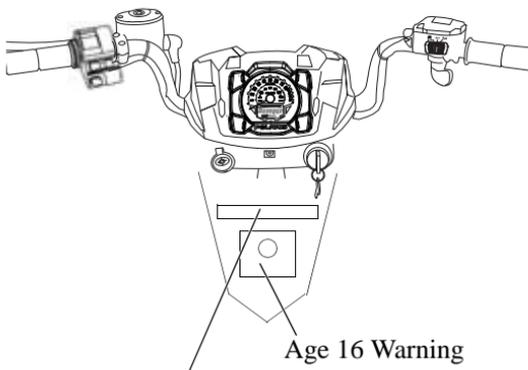

Reverse Override Warning
AWD Caution

Age 16 Warning

WARNING

Operating this ATV if you are under the age of 16 increases the chances of severe injury or death to both operator and passenger.

NEVER operate this ATV if you are under age 16.

7175375

Safety Labels and Locations

General Warning

WARNING

Improper ATV use can result in SEVERE INJURY or DEATH

ALWAYS USE AN APPROVED HELMET AND PROTECTIVE GEAR FOR DRIVER AND PASSENGER

NEVER USE ON PUBLIC ROADS

NEVER CARRY MORE THAN 1 PASSENGER

NEVER USE WITH DRUGS OR ALCOHOL

NEVER operate:

- without proper ATV training or instruction
- at speeds too fast for your skills or the conditions
- on public roads - a collision can occur with another vehicle
- with a passenger unless passenger seat is securely in place

THE OPERATOR MUST **ALWAYS**:

- use proper riding techniques to avoid overturns on hills and rough terrain and in turns
- avoid paved surfaces - pavement may seriously affect handling and control
- reduce speed and use extra caution at all times when carrying a passenger - dismount passenger when conditions require
- make sure passenger reads and understands this label and passenger safety label

LOCATE AND READ OPERATOR'S MANUAL.

FOLLOW ALL INSTRUCTIONS AND WARNINGS.



General Warning

7175844

SAFETY

Safety Labels and Locations

Passenger Warning/Discretionary Warning

WARNING

PASSENGER SAFETY

To reduce the risk of SEVERE INJURY or DEATH

NEVER CARRY MORE THAN ONE PASSENGER

NEVER RIDE AFTER USING DRUGS OR ALCOHOL

NEVER carry a passenger too small to firmly plant feet on footrests and securely grasp hand holds.

THE PASSENGER MUST **ALWAYS**:

- use an approved helmet and protective gear
- securely grasp hand holds and plant feet firmly on footrests while seated in the passenger seat
- tell operator to slow down or stop if uncomfortable - get off and walk if conditions require



Passenger Warning
Discretionary Warning

WARNING

- Never operate this ATV on HILLS steeper than 15 degrees $\leq 15^\circ$. To prevent overturn on hilly terrain, use throttle and brakes gradually, and shift weight uphill.
- REVERSE operation can be dangerous even at low speeds. Steering becomes difficult. To prevent loss of control, avoid sudden braking or sharp turns.

7175845

Tire Pressure/Load Warning

WARNING

Improper tire pressure or overloading can cause loss of control.

Loss of control can result in severe injury or death.

- Cold tire pressure:
 - Front: 7.0 psi (48.3 kPa)
 - Rear: 5.0 psi (34.5 kPa)
- Maximum weight capacity: 735 lbs. (333 kg)
- Lug nut torque values:
 - Steel rims 45 ft-lbs. (61 Nm)
 - Aluminum rims 75 ft-lbs. (102 Nm)

Tire Pressure/Load
Warning



7175846

Safety Labels and Locations

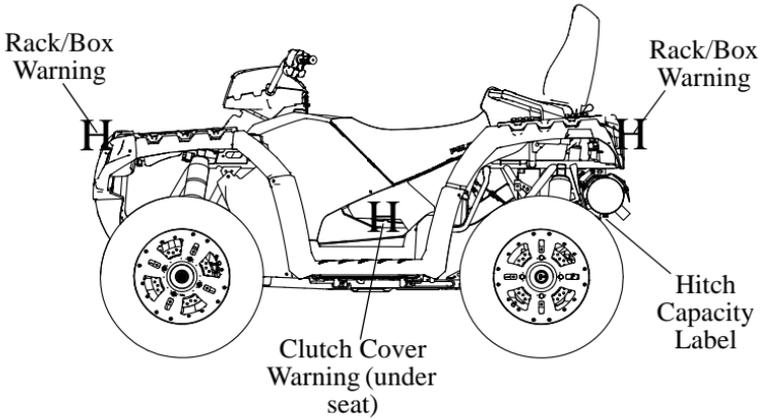

Rack/Box Warning

WARNING

- DO NOT TOW FROM RACK OR BUMPER. Vehicle damage or tipover may result causing severe injury or death. Tow only from tow hooks or hitch.
- Maximum Rack Loads: Front 120 lbs. (54 kg) Rear 240 lbs. (109 kg)

7175448

Clutch Cover Warning

WARNING

- Moving parts hazard under belt-clutch guard. To prevent serious injury, do not operate vehicle with guard removed.
- Do not modify engine or clutch. Doing so can cause part failure, possible imbalance, and excessive engine RPM, which can result in serious injury or death.

7175488

Hitch Capacity Label

TRAILER MAX WEIGHT:

1500 LBS. (682 KG) ON LEVEL GROUND

850 LBS. (386 KG) UP TO 15° GRADE

HITCH MAX. VERTICAL WEIGHT: 150 LBS. (68 KG)

7175059

FEATURES AND CONTROLS

Switches

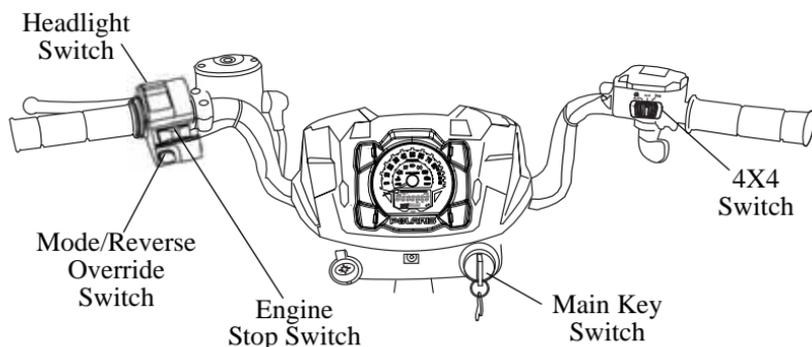

Mode/Reverse Override Switch

This vehicle is equipped with a reverse speed limiter system. To gain additional wheel speed while backing, release the throttle and depress the override button.

WARNING! Pressing the override button while the throttle is open can cause loss of control, which may result in serious injury or death. Always release the throttle before pressing the override button.

The reverse override button also acts as a MODE button when held down for approximately one half second. See the instrument cluster information beginning on page 40.

Tip: The override button will not function as a MODE button if the transmission is in reverse.

4X4 Switch

Use the 4X4 switch to engage ADC 4X4, 4X4 or 2X4. See page 39. The vehicle automatically engages 4X4 when operating in reverse if the switch is set to either 4X4 position.

FEATURES AND CONTROLS

Switches

Engine Stop Switch

Move the stop switch either left or right to the OFF position to stop the engine quickly. Move the stop switch to the RUN position before attempting to start the engine. The engine will not start or run when the switch is off.

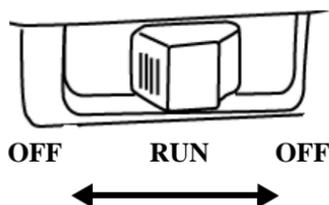

Both the main switch and the engine stop switch will shut off all electrical power to the vehicle, including lights.

Main Key Switch

Use the main key switch to start the engine. See page 57.

Headlight Switch

Use the headlight switch to turn the lights on and off and to change the lights from high beam to low beam. The key must be in the ON position and the engine stop switch must be in the RUN position.

FEATURES AND CONTROLS

Throttle Lever

⚠ WARNING

Operating an ATV with sticking or improperly operating throttle controls could cause an accident. Never start or operate an ATV that has a sticking or improperly operating throttle. Always contact your dealer for service before operating the vehicle.

Failure to check or maintain proper operation of the throttle system can result in an accident if the throttle lever sticks during operation. Always check the lever for free movement and return before starting the engine. Also check occasionally during operation.

Modifications to the electronic throttle control could result in failure to perform as designed, which could result in an accident. Do not attempt to modify the throttle control system or replace it with any after market throttle mechanisms. Always ensure that the throttle cable is installed and properly routed to the throttle control.

Engine speed and vehicle movement are controlled by pressing the throttle lever. The throttle lever is spring loaded. Engine speed returns to idle when the lever is released.

This ATV is equipped with POLARIS Electronic Throttle Control (ETC), which is designed to reduce the risk of a frozen or stuck throttle.

If the throttle cable should stick in an open position when the operator releases the throttle lever, engine speed will be limited, and power to the rear wheels will be reduced.

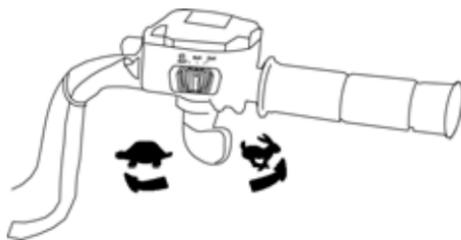

FEATURES AND CONTROLS

Brake Lever

⚠ WARNING

Operating the ATV with a spongy brake lever can result in loss of braking, which could cause an accident. Never operate the ATV with a spongy-feeling brake lever. Always contact your dealer for service before operating the vehicle.

Squeeze the brake lever toward the handlebar to apply the front and rear brakes. These brakes are hydraulically activated disc type brakes that are activated by only one lever.

Always test brake lever travel and master cylinder fluid level before riding. When squeezed, the lever should feel firm. Any sponginess would indicate a possible fluid leak or low master cylinder fluid level, which must be corrected before riding. Contact your dealer for proper diagnosis and repairs.

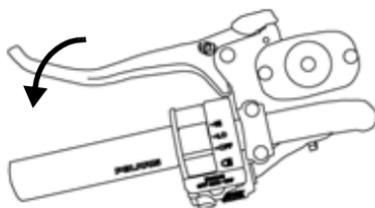

FEATURES AND CONTROLS

Master Cylinder/Brake Fluid

⚠ WARNING

An over-full master cylinder may cause brake drag or brake lock-up, which could result in an accident. Maintain brake fluid at the recommended level. Do not overfill.

Never store or use a partial bottle of brake fluid. Brake fluid is hygroscopic, meaning it rapidly absorbs moisture from the air. The moisture causes the boiling temperature of the brake fluid to drop, which can lead to early brake fade and the possibility of brake failure, which could result in an accident. After opening a bottle of brake fluid, always discard any unused portion.

Check the brake fluid in the master cylinder before each ride.

1. Position the ATV on a level surface.
2. Position the handlebars so the master cylinder is level.
3. View the brake fluid level through the indicator window on the top of the master cylinder. The eye will appear dark when the fluid level is full. When fluid is low, the eye will be clear.
4. If the fluid level is low, remove the cover screws and add fluid to the fill line. *Do not overfill.* Use DOT 4 brake fluid only.
5. Reinstall the cover. Torque screws to 7 in. lbs. (.8 Nm).

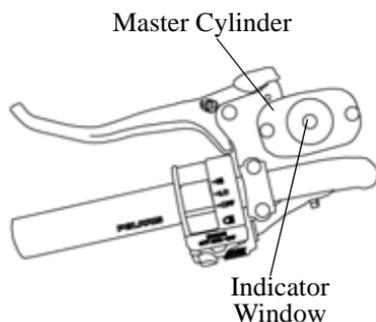

FEATURES AND CONTROLS

Parking Brake

Locking the Parking Brake

1. Place the transmission in PARK.
2. Squeeze and release the brake lever two or three times, then squeeze and hold.
3. Push the parking brake lock forward to engage the lock.
4. Release the brake lever.
5. To release the parking brake lock, squeeze and release the brake lever. It will return to its unlocked position.

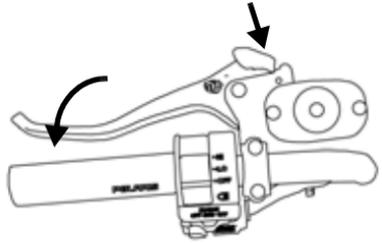

WARNING! Operating the ATV while the parking brake is engaged could result in an accident or fire. Always check to be sure the parking brake is disengaged before operating.

The parking brake may relax if left on for a long period of time. Always block the wheels to prevent rolling. Always block the wheels on the downhill side of the ATV if leaving it parked on a hill. Another option is to park the ATV in a sidehill position. Never depend on the parking brake alone if the ATV is parked on a hill. Always block the wheels to prevent rolling.

FEATURES AND CONTROLS

Auxiliary Foot Brake

⚠ WARNING

Never back down a hill. Applying the auxiliary brake when backing down a hill may cause rear tipover, which could result in serious injury or death.

Use caution when applying the auxiliary brake. Do not aggressively apply the auxiliary brake when going forward. The rear wheels may skid and slide sideways, causing loss of control and serious injury or death.

The auxiliary brake system is intended to be used as a backup for the main brake system. Should the main system fail, use the auxiliary foot brake.

The auxiliary foot brake is located on the inside of the right footrest. Operate this brake with your right foot.

If the rear wheels slide while using the auxiliary brake, *reduce* brake pedal pressure to brake the rear wheels without skidding.

Brake Fluid Level

Check the brake fluid level frequently for the auxiliary brake system. The reservoir is located under the front storage box. See page 36.

Maintain the fluid level between the maximum and minimum marks. Use DOT 4 brake fluid only.

NOTICE: Do not use ADC fluid in the brake fluid reservoir. ADC fluid will damage the rubber components of the brake system.

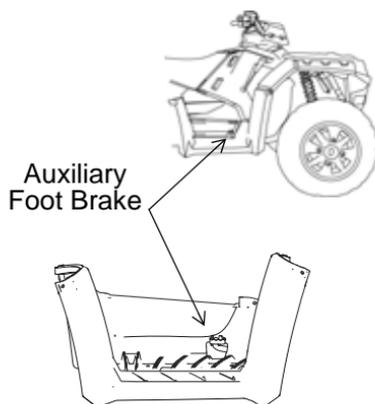

Brake Fluid Reservoir



FEATURES AND CONTROLS

Automatic Transmission Gear Selector

The transmission gear selector is located on the right side of the vehicle.

H: High Gear

L: Low Gear

N: Neutral

R: Reverse

P: Park

To shift gears, brake to a complete stop. When the engine is idling, move the lever to the desired gear.

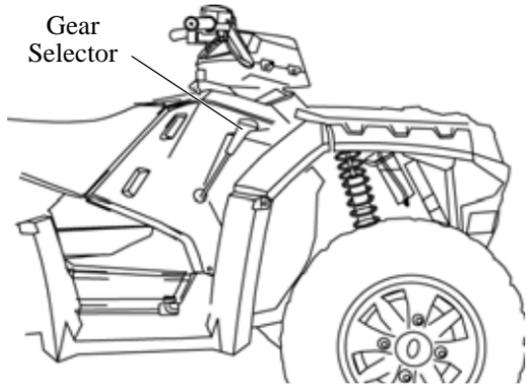

NOTICE: Shifting gears with the engine speed above idle or while the vehicle is moving could cause transmission damage.

Whenever the ATV is left unattended, always place the transmission in PARK and lock the parking brake.

Belt Life

To extend belt life, use low forward gear when pulling a heavy load at less than seven miles per hour for extended periods and when operating uphill at a slow speed.

FEATURES AND CONTROLS

Electronic Power Steering (EPS)

Electronic power steering engages when the ignition key is turned to the ON position. EPS remains engaged whether the vehicle is moving or idle. See page 41 for EPS Warning Indicator information.

Passenger Seat

Always make sure the passenger seat is installed and securely latched before operating with a passenger. Test the seat latch by attempting to pull the seat upward. *If the lock-out is not working properly, do not allow a passenger to ride the vehicle.* See your POLARIS dealer for service.

See pages 95-96 for passenger seat adjustment procedures.

See page 95 for passenger seat removal and installation procedures.

Beverage Holders

This vehicle is equipped with beverage holders on each side of the passenger seat. To secure a beverage or other container, remove the rubber retainer strap from one side of the holder. Place the container into the recess and reinstall the strap over the top of the container. Place one of the rubber cylinders through one of the holes to secure a strap.

When trailering the vehicle, and whenever a holder is not in use, always secure the rubber straps in one of the tighter positions to prevent loss of the retainer.



Tight Position



Less Tight Position

FEATURES AND CONTROLS

Fuel Tank

Always refuel with the engine stopped, and outdoors or in a well ventilated area. Refuel on a level surface.

Remove the fuel tank cap and add fuel. Use either leaded or unleaded gasoline with a minimum pump octane number of $87 = (R + M/2)$ octane. *Do not use fuel with ethanol content greater than 10%, such as E-85 fuel.*

The fuel tank is designed to allow for the normal expansion of fuel. Do not overfill. Do not fill the tank neck.



FEATURES AND CONTROLS

Front Storage Box

Open the front storage box to access the under-compartment area.

1. Release the front box cover latches and lift the cover.
2. Release the plunger latches that secure the box to the frame.
3. Close the cover and lift the unlatched edge of the box to disengage the plungers. Pivot the box forward.
4. To remove the box completely, disengage the plungers and slide the box rearward and upward.
5. *Always secure the plunger latches and the cover latches before operating the vehicle.*



Cover Latches



Plunger Latches

Access the following components under the front box:

- Radiator cap
- Brake fluid reservoir
- ADC fluid reservoir
- Coolant recovery bottle cap
- Electrical/fuse/relay components
- Battery

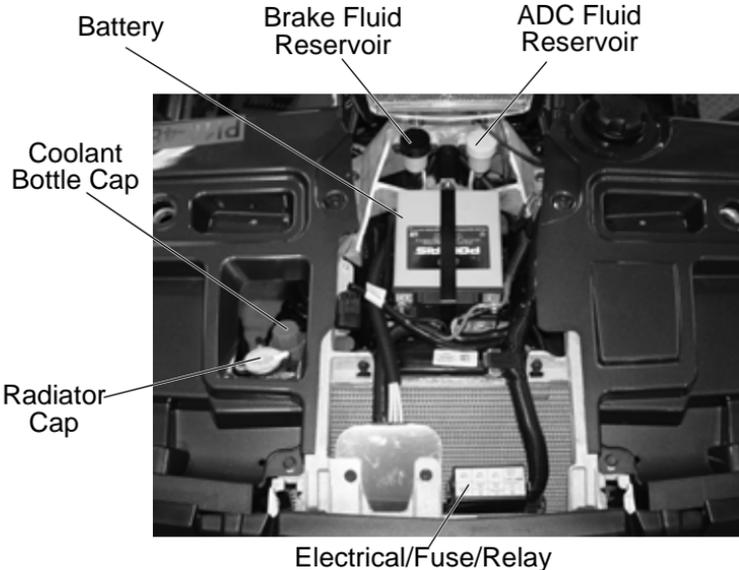

FEATURES AND CONTROLS

All Wheel Drive System

The All Wheel Drive system is controlled by the 4X4 switch.

ADC 4X4 Mode

When the switch is on ADC 4X4, the ADC system allows engine braking to all four wheels when the vehicle descends a hill or incline. Always move the 4X4 switch to ADC 4X4 before ascending or descending a hill. See page 39.

4X4 Mode

When the switch is on 4X4, the ATV is in 4X4, and the 4X4 indicator icon in the instrument cluster display will be visible.

When in 4X4, the demand drive unit will automatically engage any time the rear wheels lose traction. When the rear wheels regain traction, the demand drive unit will automatically disengage.

There is no limit to the length of time the vehicle may remain in 4X4. The vehicle automatically engages 4X4 when operating in reverse if the switch is set to either 4X4 position.

2X4 Mode

When the switch is on 2X4, the ATV is in two-wheel drive at all times.

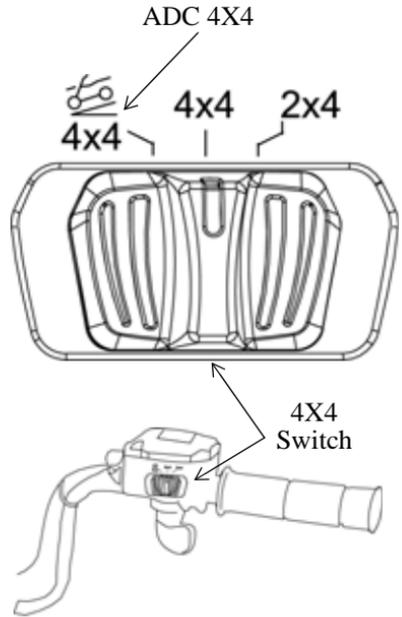

FEATURES AND CONTROLS

All Wheel Drive System

Engaging 4X4

The 4X4 switch may be turned on or off while the vehicle is moving. Initially, the vehicle's electronic system will not enable 4X4 until the engine RPM is below 3100. Once enabled, 4X4 remains enabled until the 4X4 switch is turned off. If the switch is turned off while the demand drive unit is moving, it will not disengage until the rear wheels regain traction.

Engage the 4X4 switch before getting into conditions where front wheel drive may be needed. If the rear wheels are spinning, release the throttle before switching to 4X4.

NOTICE: Switching to 4X4 or ADC 4X4 while the rear wheels are spinning may cause severe drive shaft and gearcase damage. Always switch to 4X4 or ADC 4X4 while the rear wheels have traction or are at rest.

FEATURES AND CONTROLS

Active Descent Control (ADC) System

The ADC system allows engine braking to all four wheels when the vehicle descends a hill or incline. Always move the 4X4 switch to ADC 4X4 before ascending or descending a hill.

Engaging Active Descent Control

The ADC system will automatically engage when *all four* of the following conditions occur:

- The 4X4 switch must be in the ADC 4X4 position
- Vehicle speed must be 15 mph (24 km/h) or less
- The throttle must be closed (throttle lever released)
- The transmission must be in gear (high, low or reverse)

Disengaging Active Descent Control

The ADC system will automatically disengage if *at least one* of the following conditions occur:

- The 4X4 switch is moved out of the ADC 4X4 position
- Vehicle speed exceeds 15 mph (24 km/h)
- The throttle is open (throttle is applied)
- The transmission is shifted to neutral or park

FEATURES AND CONTROLS

Instrument Cluster

NOTICE: High water pressure may damage ATV components. Wash the ATV by hand or with a garden hose using mild soap.

Certain products, including insect repellents and chemicals, will damage the speedometer lens and other plastic surfaces. Do not use alcohol to clean the instrument cluster. Do not allow insect sprays to contact the lens. Immediately clean off any gasoline that splashes on the instrument cluster.

Digital/Analog Gauge

Speedometer

The speedometer displays vehicle speed in either miles per hour (MPH) or kilometers per hour (km/h).

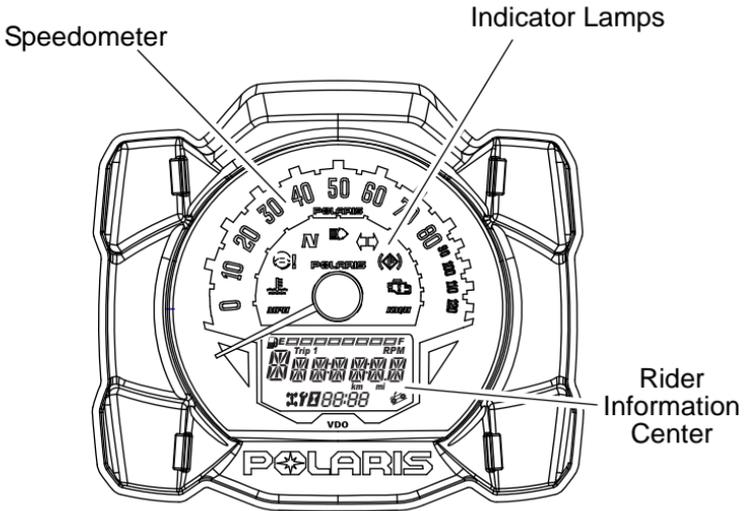

FEATURES AND CONTROLS

Instrument Cluster

Digital/Analog Gauge

Indicator Lamps

Lamp	Indicates	Condition
<i>MPH</i>	Vehicle Speed	When standard mode is selected, speed displays in miles per hour.
<i>KM/H</i>		When metric mode is selected, speed displays in kilometers per hour.
	Over Temperature	This lamp flashes to indicate an overheated engine. If the indicator stops flashing but remains illuminated, the overheating condition remains, and the system will automatically reduce engine power.
	EPS Warning	This indicator illuminates when the key is turned to the ON position and goes off when the engine is started. If the light remains on after starting the engine, the EPS system is inoperative. See your authorized POLARIS dealer for service.
<i>N</i>	Neutral	This lamp illuminates when the transmission is in neutral and the ignition key is in the ON position.
	High Beam	This lamp illuminates when the headlamp switch is set to high beam.
	Check Engine	This indicator appears if an EFI-related fault occurs. Do not operate the ATV if this warning appears. Serious engine damage could result. See your dealer.

FEATURES AND CONTROLS

Instrument Cluster

Digital/Analog Gauge

Rider Information Center

The rider information center is located in the instrument cluster. All segments will light up for one second at start-up. If the instrument cluster fails to illuminate, a battery over-voltage may have occurred and the instrument cluster may have shut off to protect the electronic speedometer. If this occurs, take the ATV to your POLARIS dealer for proper diagnosis.

The information center is set to display standard units of measurement and a 12-hour clock at the factory. To change to metric and/or a 24-hour clock, see page 45.

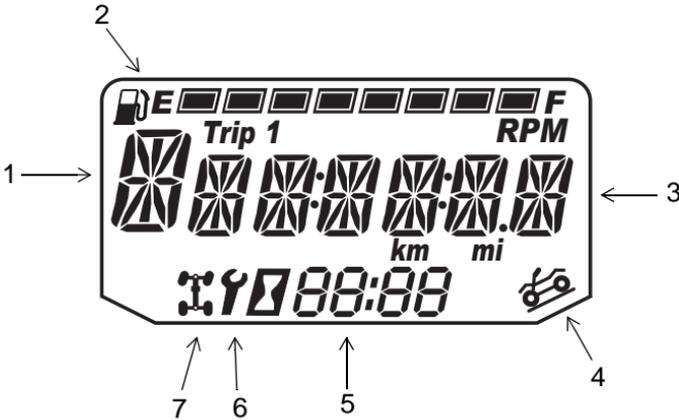

FEATURES AND CONTROLS

Instrument Cluster

Digital/Analog Gauge

Rider Information Center

1. **Gear Display** - This area displays gear shifter position.
H = High Gear
L = Low Gear
N = Neutral
R = Reverse Gear
P = Park
-- = Gear Signal Error (or shifter between gears)
2. **Fuel Gauge Display** - The segments of the fuel gauge show the level of fuel in the fuel tank. When the last segment clears, a low fuel warning is activated. All segments including the fuel icon will flash. Refuel immediately.
Tip: If the fuel icon fails to display, an open or short circuit has occurred in the fuel sensor circuit. See your dealer.
3. **Information Display** - This area displays odometer, trip meter, engine hour meter, engine speed and programmable service hour interval.
4. **Active Descent Control Display** - This icon displays when ADC is active. See page 39.
5. **Clock Display** - The clock displays time in a 12-hour or 24-hour format. If the engine is turned off, press the MODE button. The time will display for 5-10 seconds. See page 45 for resetting instructions.
6. **Service Reminder Display** - A flashing wrench symbol alerts the operator that the preset service interval has been reached. The vehicle should be brought to your dealer for scheduled maintenance. See page 45 for resetting instructions.
7. **4X4 Display** - This icon displays when the 4X4 system is engaged (switch is on either ADC 4X4 or 4X4).

FEATURES AND CONTROLS

Instrument Cluster

Digital/Analog Gauge

Rider Information Center

The reverse override button acts as the MODE button when pressed and released quickly. The transmission cannot be in reverse when using the override button as a MODE button. This feature does not contain a vehicle speed lockout function and can be used at any operating speed.

Display Units (Standard/Metric)

The display can be changed to display either standard or metric units of measurement.

Tip: To exit the set-up mode at any time, wait 10 seconds. The display automatically exits and returns to the odometer display.

	Standard Display	Metric Display
Distance	Miles	Kilometers
Fuel	U.S. Gallons	Liters, Imperial Gallons
Temperature	Fahrenheit	Celsius
Time	12-Hour Clock	24-Hour Clock

1. Turn the key to the OFF position.
2. Place the transmission in neutral.
3. Press and *hold* the MODE button while turning the key to the ON position.
4. When the display flashes the distance setting, tap the MODE button to advance to the desired setting.
5. Press and *hold* the MODE button to save the setting and advance to the next display option.
6. Repeat the procedure to change remaining display settings.

FEATURES AND CONTROLS

Instrument Cluster

Digital/Analog Gauge

Rider Information Center

Clock Mode

Tip: The clock must be reset any time the battery has been disconnected or discharged.

1. Turn the key to the ON position. Use the MODE button to toggle to the odometer display.
2. Press and *hold* the MODE button until the hour segment flashes. Release the button.
3. With the segment flashing, tap the MODE button to advance to the desired setting.
4. Press and *hold* the MODE button until the next segment flashes. Release the button.
5. Repeat steps 3-4 twice to set the 10-minute and 1-minute segments. After completing the 1-minute segment, step 4 will save the new settings and exit the clock mode.
6. Turn the key to the OFF position.

Odometer Mode

The odometer records and displays the distance traveled by the ATV.

Trip Meter Mode

The trip meter records the distance traveled by the ATV if reset before each trip. To reset, select the trip meter mode. Press and hold the MODE button until the meter resets to zero. In the Rider Information Center, the trip meter display contains a decimal point, but the odometer displays without a decimal point.

Hour Meter Mode

This mode logs the total hours the engine has been in operation.

FEATURES AND CONTROLS

Instrument Cluster

Digital/Analog Gauge

Rider Information Center

Programmable Service Interval

When the hours of engine operation equal the programmed service interval setting, the wrench icon will flash for 5 seconds each time the engine is started. When this feature is enabled, it provides a convenient reminder to perform routine maintenance. The service interval is programmed at 50 hours at the factory. Use the following procedure to change the service interval.

1. Press the MODE button until remaining service hours display.
2. Press and hold the MODE button.
3. When the service hours flash, press and release the MODE button to advance the hours to the desired setting (including OFF). Press and hold the MODE button to set the new service hour interval.

Diagnostic Display Mode

The EFI diagnostic display mode is for informational purposes only. Please see your POLARIS dealer for all major repairs.

The diagnostic mode is accessible only when the check engine warning indicator activates after the key has been turned on. Leave the key on if you want to view the active code (failure code).

The diagnostic mode becomes inaccessible if the key is turned off and on and the warning indicator is no longer active. This allows the determination of persistent as well as intermittent faults.

Inactive codes are stored in the history of the unit.

FEATURES AND CONTROLS

Instrument Cluster

Digital/Analog Gauge

Rider Information Center

Engine Error Codes

The error screen displays only when the CHECK ENGINE light is on or when it goes on and off during one ignition cycle. Error codes are not stored in the gauge when the key is turned off. The code and message is lost, but will reappear if the fault reoccurs after restarting the engine.

If the CHECK ENGINE light illuminates, retrieve the error codes from the display. Please see your Polaris dealer for all major repairs.

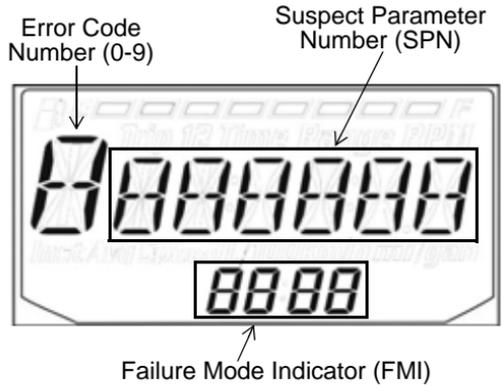

1. If the error codes are not displayed, use the MODE button to toggle until “Ck ENG” displays on the main line of the display.
2. Press and hold the MODE button to enter the diagnostics code menu.
3. Record the numbers displayed in the gear position (if any), clock and odometer displays.
4. Press the MODE button to advance to the next error code.
5. Press and hold the MODE button to exit the diagnostics code menu.
6. See pages 48-51 for code definitions and failure descriptions. Please see your Polaris dealer for all major repairs.

FEATURES AND CONTROLS

Instrument Cluster

Diagnostic Display Code Definitions

Open Load: There is a break in the wires that lead to the item listed in the chart (injector, fuel pump, etc.), or the item has failed.

Short-to-Ground: The wire is shorted to ground between the electronic control unit and the item listed in the chart.

Shorted Load: The wires leading to the item listed in the chart are shorted together, or the item has shorted internally.

Short-to-Battery: The wire leading from the item listed in the chart to the electronic control unit is shorted to a wire at battery voltage.

SPORTSMAN 550 Touring Diagnostic Codes			
Component	Condition	SPN	FMI
Throttle Position Sensor	Voltage Too High	51	3
	Voltage Too Low	51	4
Engine Temperature Sensor	Voltage Too High	110	3
	Voltage Too Low	110	4
	Temperature Too High	110	16
	Engine Overheat Shutdown	110	0
Intake Air Temperature Sensor	Voltage Too High	105	3
	Voltage Too Low	105	4
Manifold Absolute Pressure Sensor	Voltage Too High	102	3
	Voltage Too Low	102	4
Crankshaft Position Sensor	Circuit Fault	636	8
Gear Sensor Signal	Voltage Too Low (to Calibrate)	523	4
	Voltage Too High	523	3
	Signal Fault	523	2
Injector 1 (MAG)	Driver Circuit Open/Grounded	651	5
	Driver Circuit Short to B+	651	3
Ignition Coil Primary Driver 1 (MAG)	Driver Open/Grounded	1268	5
	Driver Circuit Short to B+	1268	3
Fuel Pump Driver Circuit	Driver Circuit Open/Grounded	1347	5
	Driver Circuit Short to B+	1347	3
Fan Relay Driver Circuit	Driver Circuit Open/Grounded	1071	5
	Driver Circuit Short to B+	1071	3

FEATURES AND CONTROLS

Instrument Cluster

Diagnostic Display Code Definitions

SPORTSMAN 550 Touring Diagnostic Codes			
Component	Condition	SPN	FMI
Idle Air Control	Driver Circuit Grounded	520193	5
	Shorted Load*	520193	11
Starter Enable Circuit	Driver Circuit Short to B+	1321	3
All Wheel Drive Control	Driver Circuit Short to B+	520207	3
System Power	Voltage Too High	168	3
	Voltage Too low	168	4
Throttle Safety Signal	Voltage Too High	520194	3
	Voltage Too Low	520194	4
	Signal Out of Range	520194	2
	Throttle Stuck	520194	7
Active Descent Control System	Driver Circuit Short to B+	520203	3
EPS Models Only			
Steering Over Current Shut Down	Current Above Normal or Grounded	520221	6
Steering Excessive Current Error	Current Above Normal or Grounded	520222	6
Steering Torque Sensor T1 Partial Failure	T1 Shorted to Ground	520223	4
	T1 Shorted to Bus	520223	3
Steering Torque Sensor T2 Partial Failure	T2 Shorted to Ground	520224	4
	T2 Shorted to Bus	520224	3
Steering Torque Sensor Full Failure	T1 and T2 Shorted to Ground	520225	4
	T1 and T2 Shorted to Bus	520225	3
	T1 Shorted to Ground & T2 Shorted to Bus	520225	16
	T2 Shorted to Ground & T1 Shorted to Bus	520225	17
	T1 and T2 are Shorted	520225	2
Steering Position Sensor P1 Partial Failure	P1 Shorted to Ground	520226	4
	P1 Shorted to Bus	520226	3
Steering Position Sensor P2 Partial Failure	P2 Shorted to Ground	520227	4
	P2 Shorted to Bus	520227	3
Steering Position Sensor Full Failure	P1 and P2 Shorted to Ground	520228	4
	P1 and P2 Shorted to bus	520228	3
EPAS Inverter Temperature	Greater than 110 Degrees C	520229	16
	Greater than 120 Degrees C	520229	0
EPAS CAN Communications Receive Error	No RX Message for 2 Seconds	520230	9
EPAS CAN Communications Transmit Error	No TX Message for 2 Seconds	520231	9

*Assumes unipolar configuration of stepper motor

FEATURES AND CONTROLS

Instrument Cluster

Diagnostic Display Code Definitions

SPORTSMAN 850 Touring Diagnostic Codes			
Component	Condition	SPN	FMI
Throttle Position Sensor	Voltage Too High	51	3
	Voltage Too Low	51	4
Engine Temperature Sensor	Voltage Too High	110	3
	Voltage Too Low	110	4
	Temperature Too High	110	16
	Engine Overheat Shutdown	110	0
Intake Air Temperature Sensor	Voltage Too High	105	3
	Voltage Too Low	105	4
Manifold Absolute Pressure Sensor	Voltage Too High	102	3
	Voltage Too Low	102	4
	Signal Out of Range	102	2
Crankshaft Position Sensor	Circuit Fault	636	8
	Plausibility Fault	636	2
Vehicle Speed Signal	Speed Too High	84	8
	Plausibility Fault	84	2
Gear Sensor Signal	Voltage Too Low	523	4
	Voltage too high	523	3
	Signal fault	523	2
Injector 1 (MAG) (SDI Part Load)	Driver Circuit Open/Grounded	651	5
	Driver Circuit Short to B+	651	3
	Driver Circuit Grounded	651	4
Injector 2 (PTO) (SDI Part Load)	Driver Circuit Open/Grounded	652	5
	Driver Circuit Short to B+	652	3
	Driver Circuit Grounded	652	4
Ignition Coil Primary Driver 1 (MAG)	Driver Circuit Short to B+	1268	3
Ignition Coil Primary Driver 2 (PTO)	Driver Circuit Short to B+	1269	3
Fuel Pump Driver Circuit	Driver Circuit Open/Grounded	1347	5
	Driver Circuit Short to B+	1347	3
	Driver Circuit Grounded	1347	4
Fan Relay Driver Circuit	Driver Circuit Open/Grounded	1071	5
	Driver Circuit Short to B+	1071	3
	Driver Circuit Grounded	1071	4
Idle Air Control	Driver Circuit Open/Grounded	634	5
	Driver Circuit Short to B+	634	3
	Driver Circuit Grounded	634	4
	Position Out of Range	634	7
Starter Enable Circuit	Driver Circuit Open/Grounded	1321	5
	Driver Circuit Short to B+	1321	3
	Driver Circuit Grounded	1321	4

FEATURES AND CONTROLS

Instrument Cluster

Diagnostic Display Code Definitions

SPORTSMAN 850 Touring Diagnostic Codes			
Component	Condition	SPN	FMI
Chassis Relay	Driver Circuit Open/Grounded	520208	5
	Driver Circuit Short to B+	520208	3
	Driver Circuit Grounded	520208	4
All Wheel Drive Control	Driver Circuit Open/Grounded	520207	5
	Driver Circuit Short to B+	520207	3
	Driver Circuit Grounded	520207	4
System Power	Voltage Too High	168	3
	Voltage Too low	168	4
Throttle Safety Signal	Voltage Too High	520194	3
	Voltage Too Low	520194	4
	Signal Out of Range	520194	2
	Throttle Stuck	520194	7
Active Descent Control System	Driver Circuit Open/Grounded	520203	5
	Driver Circuit Short to B+	520203	3
	Driver Circuit Grounded	520203	4
Idle Speed	Speed Too High	520211	3
	Speed Too Low	520211	4
EPS Models Only			
Steering Over Current Shutdown	Current Above Normal/Grounded	520221	6
Steering Excessive Current Error	Current Above Normal/Grounded	520222	6
Steering Torque Sensor T1 Partial Failure	T1 Shorted to Ground	520223	4
	T1 Shorted to Bus	520223	3
Steering Torque Sensor T2 Partial Failure	T2 Shorted to Ground	520224	4
	T2 Shorted to Bus	520224	3
Steering Torque Sensor Full Failure	T1 and T2 Shorted to Ground	520225	4
	T1 and T2 Shorted to Bus	520225	3
	T1 Short to Ground & T2 Short to Bus	520225	16
	T2 Short to Ground & T1 Short to Bus	520225	17
	T1 and T2 are Shorted	520225	2
Steering Position Sensor P1 Partial Failure	P1 Shorted to Ground	520226	4
	P1 Shorted to Bus	520226	3
Steering Position Sensor P2 Partial Failure	P2 Shorted to Ground	520227	4
	P2 Shorted to Bus	520227	3
Steering Position Sensor Full Failure	P1 and P2 Shorted to Ground	520228	4
	P1 and P2 Shorted to bus	520228	3
EPAS Inverter Temperature	Greater than 110 Degrees C	520229	16
	Greater than 120 Degrees C	520229	0
EPAS CAN Comm. Receive Err	No RX Message for 2 Seconds	520230	9
EPAS CAN Comm. Transmit Err	No TX Message for 2 Seconds	520231	9
IC CAN Comm. w/EPAS	EPAS Offline	520230	31

OPERATION

WARNING

Failure to operate the ATV properly can result in a collision, loss of control, accident or overturn, which may result in serious injury or death. Read and understand all safety warnings outlined in the safety section of this owner's manual.

Break-In Period

The break-in period for your new POLARIS ATV is the first ten hours of operation, or the time it takes to use the first two full tanks of gasoline. No single action on your part is as important as following the procedures for a proper break-in. Careful treatment of a new engine and drive components will result in more efficient performance and longer life for these components.

NOTICE: Excessive heat build-up during the first three hours of operation will damage close-fitted engine parts and drive components. Do not operate at full throttle or high speeds during the first three hours of use.

Break-In Period

Engine and Drivetrain Break-in

1. Fill the fuel tank with gasoline. See page 35. Always exercise extreme caution whenever handling gasoline.
2. Check the engine oil level on the dipstick. See page 81. Add oil if necessary to maintain the level between the safe and add marks.
3. Drive slowly at first. Select an open area that allows room to familiarize yourself with vehicle operation and handling.
4. Vary the throttle positions. Do not operate at sustained idle.
5. Perform regular checks on fluid levels, controls and areas outlined on the daily pre-ride inspection checklist. See page 54.
6. Pull only light loads.
7. Change both the oil and the filter at 20 hours, one month or 500 miles (800 km), whichever comes first.

PVT Break-in (Clutches/Belt)

A proper break-in of the clutches and drive belt will ensure a longer life and better performance. Break in the clutches and belt by operating at slower speeds during the break-in period as recommended. Pull only light loads. Avoid aggressive acceleration and high speed operation during the break-in period.

OPERATION

Pre-Ride Checklist

Failure to inspect and verify that the ATV is in safe operating condition before operating increases the risk of an accident. Always inspect the ATV before each use to make sure it's in safe operating condition.

Item	Remarks	Page
Passenger seat latch	Ensure latch is secure	34
Brake system/lever travel	Ensure proper operation	29 93
Brake fluid	Ensure proper level	30
Auxiliary brake	Ensure proper operation	32
Front suspension	Inspect, lubricate if necessary	80
Rear suspension	Inspect, lubricate if necessary	80
Steering	Ensure free operation	-
Tires	Inspect condition and pressure	98
Wheels/fasteners	Inspect, ensure fastener tightness	100
Frame nuts, bolts, fasteners	Inspect, ensure tightness	-
Fuel and oil	Ensure proper levels	35 81
Coolant level	Ensure proper level	91 92
Coolant hoses	Inspect for leaks	-
Throttle	Ensure proper operation	28 120
Indicator lights/switches	Ensure operation	26
Engine stop switch	Ensure proper operation	27
Air filter, pre-filter	Inspect, clean	101
Headlamp	Check operation	27 103
Brake light/taillight	Check operation	107
Riding gear	Wear approved helmet, goggles, and protective clothing	8
ADC Fluid	Ensure proper level	87

Safe Operation Practices

1. Complete the recommended safety training before operating this vehicle. See page 7.
2. Do not allow anyone under 16 years of age to operate this vehicle. Do not allow anyone with cognitive or physical disabilities to operate this vehicle.
3. Engine exhaust fumes are poisonous. Never start the engine or let it run in an enclosed area.
4. Before operating, learn how to use the auxiliary brake for emergency situations (if service brakes become inoperable).
5. Operate this vehicle off-road only. Never operate the vehicle on pavement or on any public street, road or highway, including dirt and gravel roads.
6. Use caution and drive at reduced speeds in conditions of reduced visibility such as fog, rain and darkness. Clean headlights frequently and replace burned out headlamps promptly.
7. Drive in a manner appropriate for your skills, your passenger's skills and operating conditions. Never operate at excessive speeds. Never attempt wheelies, jumps, or other stunts. Never remove your hands from the handlebars while operating, and always keep both feet on the footrests.
8. Never consume alcohol or drugs before or while operating an ATV.
9. Always use the size and type of tires specified for your vehicle. Always maintain proper tire pressure.
10. Never operate a damaged ATV. After any overturn or accident, have a qualified service dealer inspect the entire machine for possible damage.
11. Never operate the ATV on a frozen body of water unless you have independently verified that the ice is sufficiently thick to support the weight and moving force of the ATV, you and your cargo, together with any other vehicles in your party.
12. Do not touch hot exhaust system components. Always keep combustible materials away from the exhaust system.
13. Always remove the ignition key when the vehicle is not in use to prevent unauthorized use.

OPERATION

Know Your Riding Area/Tread Lightly

Familiarize yourself with all laws and regulations concerning the operation of this off-road vehicle in your area. Respect the environment in which you ride. Find out where the designated riding areas are by contacting your POLARIS dealer, a local riding club or local officials.

Help keep our trails open for recreational vehicle use. As an off-road enthusiast, you represent the sport and can set a good example (or a poor example) for others to follow. Tread lightly. Operate with respect for the terrain, avoid littering, and always stay on the designated trails.

Trail Etiquette

Always practice good etiquette when riding. Allow a safe distance between your vehicle and other vehicles operating in the same area. Communicate to oncoming operators by signaling the number of vehicles in your group. When stopping, move your vehicle to the edge of the trail as far as possible to allow others to pass safely.

Starting the Engine

1. Position the vehicle on a level surface outdoors or in a well-ventilated area.
2. Place the transmission in PARK.
3. Lock the parking brake.

Tip: The starter interlock will prevent the engine from starting if the transmission is in gear and the brake is not engaged.

4. Sit on the vehicle and move the engine stop switch to RUN.

Tip: Do not press the throttle while starting the engine.

5. Turn the ignition key past the ON position to engage the starter. Activate the starter for a maximum of five seconds, releasing the key when the engine starts.
6. If the engine does not start, return the key to the OFF position and wait five seconds before attempting to start again. Activate the starter for another five seconds if necessary. Repeat this procedure until the engine starts.

NOTICE: Operating the vehicle immediately after starting could cause engine damage. Allow the engine to warm up for several minutes before operating the vehicle.

Cold Weather Operation

If the ATV is used year-round, check the oil level frequently. A rising oil level could indicate the accumulation of contaminants such as water or excess fuel in the bottom of the crankcase. Water in the bottom of the crankcase can lead to engine damage and must be drained. Water accumulation increases as outside temperature decreases.

OPERATION

Driving Procedures



1. Wear protective riding gear. See page 8.
2. Perform the pre-ride inspection. See page 54.
3. Place the transmission in PARK.
4. Lock the parking brake.
5. Mount the vehicle from the left side.
6. Sit upright with both feet on the footrests and both hands on the handlebars.
7. Start the engine and allow it to warm up.
8. Shift the transmission into gear.
9. Check your surroundings and determine your path of travel.
10. Release the parking brake.
11. Slowly depress the throttle with your right thumb and begin driving.
12. Drive slowly. Practice maneuvering and using the throttle and brakes on level surfaces.

Turning the Vehicle

Both rear wheels drive equally at all times. This means that the outside wheel must travel a greater distance than the inside wheel when turning, and the inside tire must slip traction slightly.

1. Slow down.
2. Never turn quickly when carrying a passenger or cargo.
3. Steer in the direction of the turn.
4. Keep both feet on the footrests.
5. Lean your upper body to the inside of the turn while supporting your weight on the outer footrest. This technique alters the balance of traction between the rear wheels, allowing the turn to be made smoothly. The same leaning technique should be used for turning in reverse.
6. Practice making turns at slow speeds before attempting to turn at faster speeds.

WARNING! Turning improperly can result in vehicle overturn. Never turn abruptly or at sharp angles. Never turn at high speeds.



OPERATION

Driving with a Passenger

1. Never allow anyone under 12 years of age to ride as a passenger on this 2-up ATV. Make sure any passenger is tall enough to comfortably and safely reach the grab handles and footrests.
2. Do not carry a passenger until you have at least two hours of driving experience with this vehicle.
3. Make sure the passenger is wearing appropriate riding gear, including an approved helmet with a rigid chin guard. See page 8.
4. Perform the pre-ride inspection. See page 54.
5. Always make sure the passenger seat is installed and securely latched before operating with a passenger.
6. Lock the parking brake.
7. Mount the vehicle from the left side. After the operator is seated, the passenger should mount the vehicle from the left side. Always make sure the brake is engaged to ensure the vehicle remains motionless whenever a passenger mounts or dismounts.
8. Allow a passenger to ride only in the approved passenger seat.
9. Do not carry more than one passenger.
10. Slow down. Control may be more difficult with a passenger on board. Allow more time and distance for braking.



Driving with a Passenger

11. Ride to the ability of your passenger, instead of to your own ability. Avoid unexpected or aggressive maneuvers that could cause a passenger to fall from the vehicle.
12. Do not cross a hillside with a passenger on board. See page 64.
13. A passenger should always be seated in the passenger seat with both feet on the footrests and both hands on the passenger grab handles at all times. The passenger should never hold on to the operator. Never secure a passenger to the vehicle or to the operator with a belt, rope or similar device.
14. Make sure the passenger understands the importance of "active riding." When hill-climbing or performing maneuvers, a passenger should shift body weight in the same manner in which the driver shifts body weight. For example, the passenger should lean to the inside of a turn along with the operator and should always lean uphill when climbing and descending hills.

OPERATION

Driving on Slippery Surfaces

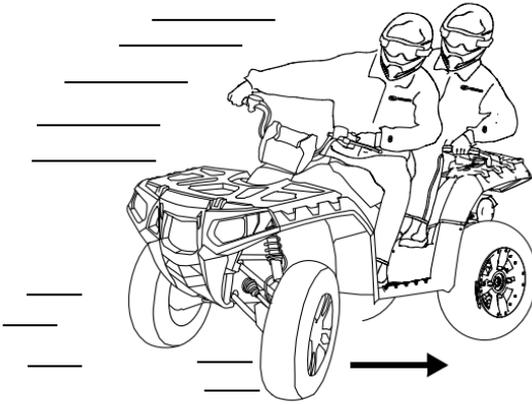

Whenever riding on slippery surfaces such as wet trails or loose gravel, or during freezing weather, follow these precautions:

1. Do not operate on excessively rough, slippery or loose terrain.
2. Slow down when entering slippery areas.
3. Engage 4X4 before wheels begin to lose traction.

NOTICE: Severe damage to drive train may occur if the 4X4 is engaged while the wheels are spinning. Allow the rear wheels to stop spinning before engaging 4X4, or engage 4X4 before wheels begin to lose traction.

4. Maintain a high level of alertness, reading the trail and avoiding quick, sharp turns, which can cause skids.
5. Never apply the brakes during a skid. Correct a skid by turning the handlebars in the direction of the skid and shifting your body weight forward.

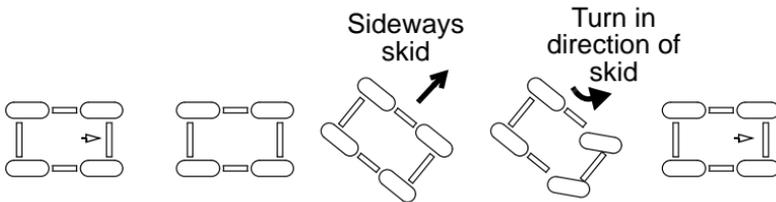

Driving Uphill

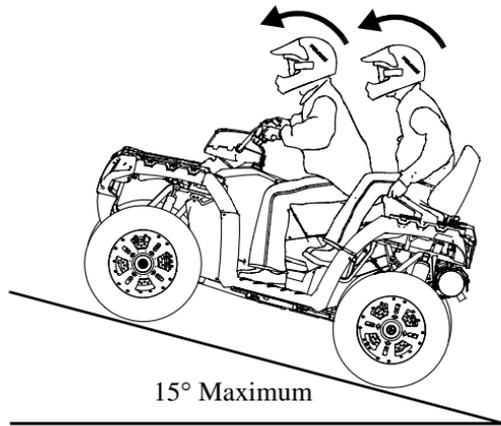

Braking and handling are greatly affected when operating in hilly terrain. Improper procedure could cause loss of control or overturn. Whenever traveling uphill, follow these precautions:

1. Always move the 4X4 switch to ADC 4X4 before ascending or descending a hill. See page 39.
2. Drive straight uphill.
3. Avoid steep hills (15° maximum).
4. Always check the terrain carefully before ascending any hill.
5. Never climb hills with excessively slippery or loose surfaces.
6. Keep both feet on the footrests.
7. Shift body weight uphill. A passenger should also shift body weight uphill.
8. Proceed at a steady rate of speed and throttle opening. Opening the throttle suddenly could cause the ATV to flip over backwards.
9. Never go over the top of any hill at high speed. An obstacle, a sharp drop, or another vehicle or person could be on the other side of the hill.
10. Remain alert and be prepared to take emergency action. This may include quick dismounting of the vehicle.

OPERATION

Driving on a Sidehill (Sidehilling)



Driving on a sidehill is not recommended. Improper procedure could cause loss of control or overturn. Avoid crossing the side of any hill unless absolutely necessary.

If crossing a sidehill is *unavoidable*, follow these precautions:

1. Slow down.
2. Avoid crossing the side of a steep hill.
3. Do not cross a hillside with a passenger on board. Ask the passenger to dismount and walk across the hillside before remounting the vehicle.
4. Lean into the hill, transferring your upper body weight toward the hill while keeping your feet on the footrests.
5. If the vehicle begins to tip, quickly turn the front wheel downhill, if possible, or dismount on the uphill side *immediately!*

Driving Downhill

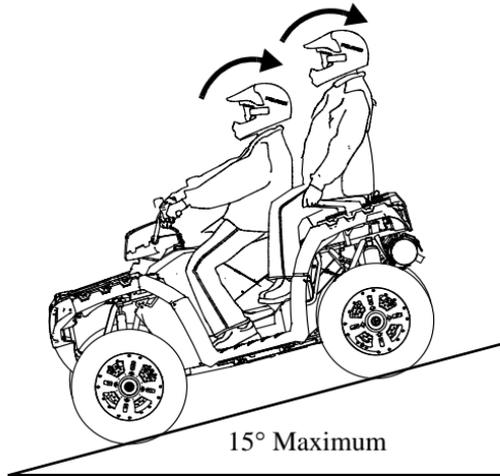

When driving downhill, follow these precautions:

1. Always check the terrain carefully before descending a hill.
2. Always move the 4X4 switch to ADC 4X4 before ascending or descending a hill. See page 39.
3. Always descend a hill with the transmission in forward gear. Do not descend a hill with the transmission in neutral.
4. Slow down. Never travel down a hill at high speed.
5. Drive straight downhill. Avoid traveling down a hill at an angle, which would cause the vehicle to lean sharply to one side.
6. Shift body weight uphill. A passenger should also shift body weight uphill.
7. Apply the brakes *slightly* to aid in slowing. Applying the brakes too firmly may cause the rear wheels to lock, which could result in loss of control.

OPERATION

Turning Around on a Hill (K-Turn)

If the vehicle stalls while climbing a hill, never back it down the hill!
Use the K-turn to turn around.

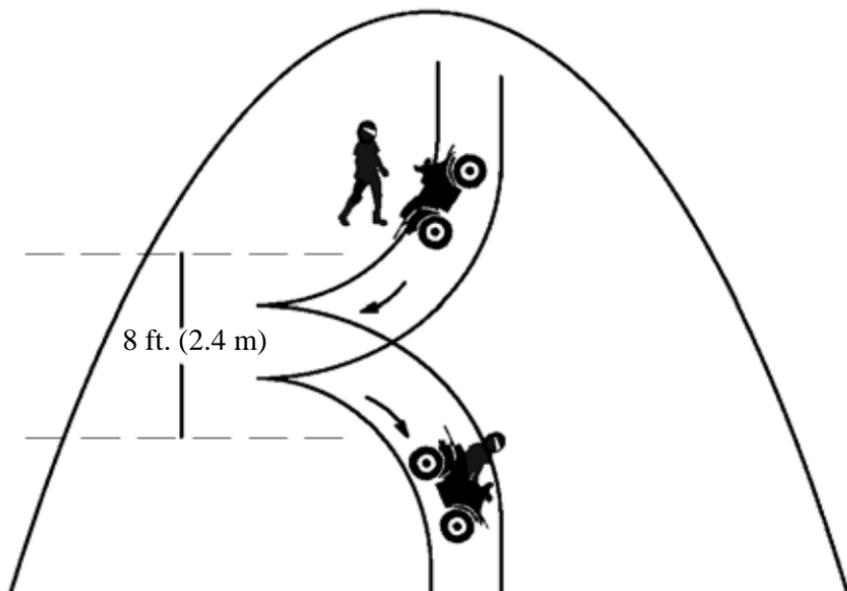

Turning Around on a Hill (K-Turn)

1. Stop and lock the parking brake while keeping body weight uphill.
2. Always move the 4X4 switch to ADC 4X4 before ascending or descending a hill. See page 39.
3. Leave the transmission in forward and shut off the engine.
4. If a passenger is on board, ask the passenger to dismount first, then the operator may dismount. Dismount on the uphill side of the vehicle, or on the left if the vehicle is pointing straight uphill. *A passenger should not remount until the vehicle returns to firm, level ground.*
5. Staying uphill of the vehicle, turn the handlebars full left.
6. While holding the brake lever, release the parking brake lock and slowly allow the vehicle to roll around to your right until it's pointing across the hill or slightly downward.
7. Lock the parking brake. Remount the vehicle from the uphill side, keeping body weight uphill. A passenger should not remount until the vehicle returns to firm, level ground.
8. Start the engine with the transmission still in forward.
9. Release the parking brake and proceed *slowly*, controlling speed with the brake lever, until the vehicle is on more level ground.

OPERATION

Driving Through Water

Your ATV can operate through water with a maximum recommended depth equal to the bottom of the footrests. Follow these procedures when operating through water:



1. Determine water depths and current before entering water.
2. Choose a crossing where both banks have gradual inclines.
3. Avoid operating through deep or fast-flowing water.

NOTICE: Major engine damage can result if the vehicle is not thoroughly inspected after operation in water. Perform the services outlined in the maintenance chart. See page 76. The following areas need special attention: engine oil, transmission oil, demand drive fluid and all grease fittings.

If the vehicle tips or overturns in water, or if the engine stops during or after operating in water, restarting can result in serious engine damage. Transport the vehicle to your dealer for service before restarting the engine. If this is not possible, follow the vehicle immersion inspection and drying procedures outlined on page 110, then see your dealer for service at the first opportunity.

4. After leaving water, test the brakes. Apply them lightly several times while driving slowly. The friction will help dry out the pads.

If it's unavoidable to enter water deeper than the footrest level:

- Proceed slowly. Avoid rocks and obstacles.
- Balance your weight carefully. Avoid sudden movements.
- Maintain a steady rate of speed. Do not make sudden turns or stops. Do not make sudden throttle changes.

Driving Over Obstacles

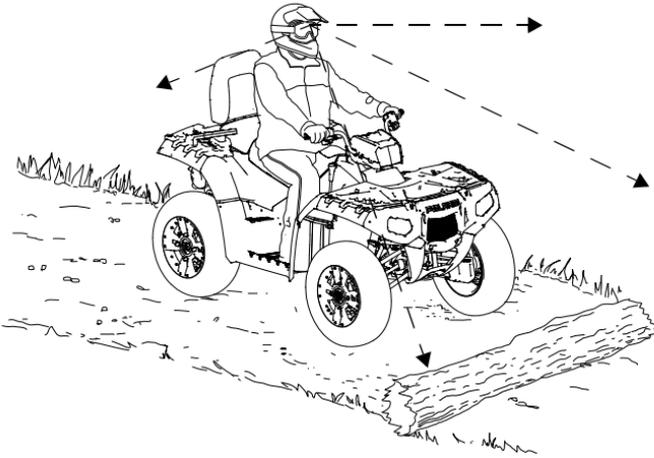

Follow these precautions when operating over obstacles:

1. Always check for obstacles before operating in a new area.
2. Look ahead and learn to read the terrain. Be constantly alert for hazards such as logs, rocks and low hanging branches.
3. Travel slowly and use extra caution when operating on unfamiliar terrain. Not all obstacles are immediately visible.
4. Never attempt to operate over large obstacles, such as rocks or fallen trees.
5. Always have a passenger dismount before operating over an obstacle that could cause a fall from the vehicle or vehicle tipover.

OPERATION

Driving in Reverse

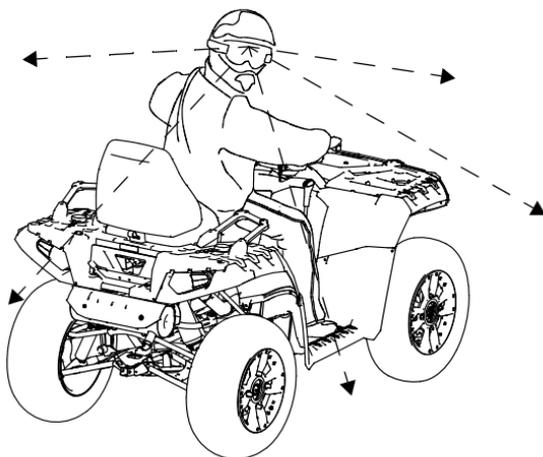

Follow these precautions when operating in reverse:

1. Always check for obstacles or people behind the vehicle. Be aware that a passenger can obstruct your view.
2. Always avoid backing downhill.
3. Back slowly.
4. Apply the brakes *lightly* for stopping.
5. Avoid turning at sharp angles.
6. Never open the throttle suddenly.
7. Do not use the override switch unless additional wheel speed is required for vehicle movement. Use the override with caution as rearward vehicle speed is greatly increased. Do not operate at wide open throttle. Operate the throttle just enough to maintain a desired speed.

NOTICE: Excessive throttle operation while in the speed limit mode may cause fuel to build in the exhaust, resulting in engine popping and/or engine damage.

Parking on an Incline

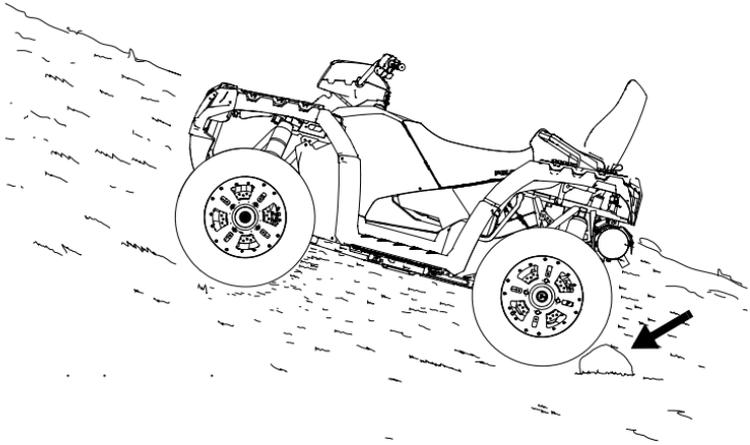

Avoid parking on an incline if possible. If it's unavoidable, follow these precautions:

1. Stop the engine.
2. Place the transmission in PARK.
3. Lock the parking brake.
4. Always block the rear wheels on the downhill side.

OPERATION

Hauling Cargo

WARNING

Overloading the vehicle or carrying or towing cargo improperly can alter vehicle handling and may cause loss of control or brake instability, which can result in serious injury or death. Always follow these precautions when hauling cargo:

Never carry cargo on the rear rack when operating the ATV in the 2-up mode with a passenger.

REDUCE SPEED AND ALLOW GREATER DISTANCES FOR BRAKING WHEN HAULING CARGO.

NEVER EXCEED THE MAXIMUM WEIGHT CAPACITY of the vehicle. When determining the weight you are adding to the vehicle, include the weight of the operator, passenger, accessories, loads in the rack or box and the load on the trailer tongue. The combined weight of these items must not exceed the maximum weight capacity.

CARGO WEIGHT DISTRIBUTION should be 1/3 on the front rack and 2/3 on the rear rack. When operating over rough or hilly terrain, reduce speed and cargo to maintain stable driving conditions. Carrying loads on only one rack increases the possibility of vehicle overturn.

CARRY LOADS AS LOW ON THE RACKS AS POSSIBLE. Carrying loads high on the racks raises the center of gravity of the vehicle and creates a less stable operating condition.

SECURE ALL LOADS BEFORE OPERATING. Unsecured loads can create unstable operating conditions, which could result in loss of control of the vehicle.

OPERATE ONLY WITH STABLE AND SAFELY ARRANGED LOADS. When handling off-centered loads that cannot be centered, securely fasten the load and operate with extra caution. Always attach the tow load to the hitch point designated for your vehicle.

HEAVY LOADS CAN CAUSE BRAKING AND CONTROL PROBLEMS. Use extreme caution when applying brakes with a loaded vehicle. Avoid terrain or situations that may require backing downhill.

USE EXTREME CAUTION when operating with loads that extend over the rack sides. Stability and maneuverability may be adversely affected, causing the vehicle to overturn.

DO NOT BLOCK THE FRONT HEADLIGHT BEAM when carrying loads on the front rack.

DO NOT TRAVEL FASTER THAN THE RECOMMENDED SPEEDS. The vehicle should never exceed 10 mph (16 kph) while towing a load on a level surface. Vehicle speed should never exceed 5 mph (8 kph) when towing loads in rough terrain, while cornering, or while ascending or descending a hill.

Hauling Cargo

Never exceed the weight capacities specified for your ATV on warning labels and in the specifications section of this manual.

1. Cargo weight should be evenly distributed ($\frac{1}{3}$ on the front rack and $\frac{2}{3}$ on the rear rack) and mounted as low as possible.
2. When operating over rough or hilly terrain, reduce speed and cargo weight to maintain stable driving conditions.
3. Do not obstruct the headlight beam with cargo.
4. Slow down.
5. Use low forward gear when hauling or towing heavy cargo to extend belt life.
6. Always operate the vehicle with extreme caution whenever hauling or towing loads. Balance, handling, and control may be affected.

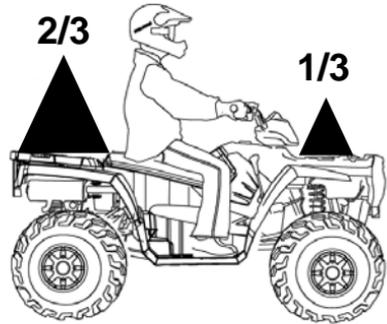

OPERATION

Hauling Cargo

Towing Loads

Always attach a towed load to the hitch point. Remove the hitch from the ATV when not towing a trailer. If towing a load, reduce rear rack cargo weight by the amount of tongue weight.

- The combination of rear rack cargo weight and tongue weight must not exceed the rear rack capacity.
- The total load (operator, passenger, accessories, cargo and weight on hitch) must not exceed the maximum weight capacity of the vehicle.

NOTICE: Using an improper hitch or exceeding the maximum tongue weight capacity can result in serious damage to the vehicle and will void your ATV warranty. Never install a hitch longer than 4" (10 cm). Never install automotive accessories on your POLARIS ATV. Always install POLARIS-approved (or equivalent) accessories designed for ATV use.

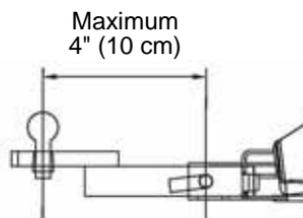

Maximum Towing Capacities

Do not exceed maximum towing capacities. Avoid towing on inclines.

	550	850
Maximum Towed Load (Level Ground)	1500 lbs. (680 kg)	1500 lbs. (680 kg)
Maximum Vertical Hitch Weight	150 lbs. (68 kg)	150 lbs. (68 kg)

EMISSION CONTROL SYSTEMS

Noise Emission Control System

Do not modify the engine, intake or exhaust components, as doing so may affect compliance with U.S.A. EPA noise control requirements (40 CFR 205) and local noise level requirements.

Operation on Public Lands in the U.S.A.

Your POLARIS vehicle has a spark arrestor that was tested and qualified to be in accordance with the USFS standard 5100-1c. Federal law requires that this spark arrestor be installed and functional when the vehicle is operated on public lands.

Operation of off-road vehicles on public lands in the U.S.A. is regulated by 43 CFR 420. Violations are subject to monetary penalties. Federal regulations can be viewed online at www.gpoaccess.gov/ecfr/.

Crankcase Emission Control System

This engine is equipped with a closed crankcase system. Blow-by gases are forced back to the combustion chamber by the intake system. All exhaust gases exit through the exhaust system.

Exhaust Emission Control System

Exhaust emissions are controlled by engine design. An electronic fuel injection (EFI) system controls fuel delivery. The engine and EFI components are set at the factory for optimal performance and are not adjustable.

The vehicle compliance labels can be found on the frame tubing of the vehicle.

Electromagnetic Interference

This spark ignition system complies with Canadian standard ICES-002.

This vehicle complies with the EMC requirements of European directives 97/24/EC and 2004/108/EC.

Non-ionizing Radiation: This vehicle emits some electromagnetic energy. People with active or non-active implantable medical devices (such as heart monitoring or controlling devices) should review the limitations of their device and the applicable electromagnetic standards and directives that apply to this vehicle.

MAINTENANCE

Periodic Maintenance Chart

Careful periodic maintenance will help keep your vehicle in safe, reliable condition. Inspect, clean, lubricate, adjust and replace parts as necessary. When inspection reveals the need for replacement parts, use genuine POLARIS parts available from your POLARIS dealer. Record maintenance and service in the Maintenance Log beginning on page 144.

Service and adjustments are important for proper vehicle operation. If you're not familiar with safe service and adjustment procedures, have a qualified dealer perform these operations.

Maintenance intervals in the following chart are based upon average riding conditions and an average vehicle speed of approximately 10 miles per hour. Vehicles subjected to severe use must be inspected and serviced more frequently.

Severe Use Definition

- Frequent immersion in mud, water or sand
- Racing or race-style high RPM use
- Prolonged low speed, heavy load operation
- Extended idle
- Short trip cold weather operation

Pay special attention to the oil level. A rise in oil level during cold weather can indicate contaminants collecting in the oil sump or crankcase. Change oil immediately if the oil level begins to rise. Monitor the oil level, and if it continues to rise, discontinue use and determine the cause or see your dealer.

Periodic Maintenance Chart

WARNING

Improperly performing the procedures marked with a **n** could result in component failure and cause an accident, which may result in serious injury or death. Always have an authorized POLARIS dealer perform these services.

Maintenance Chart Key

- ▶ Perform more often for vehicles subjected to severe use.
- E** Emission-related service (Failure to conduct this maintenance will not void the emissions warranty but may affect emissions.)
- n** Have an authorized POLARIS dealer perform these services.

MAINTENANCE

Periodic Maintenance Chart

Perform all services at whichever maintenance interval is reached first.

Item		Maintenance Interval (whichever comes first)			Remarks
		Hours	Calendar	Miles (Km)	
	Steering	-	Pre-Ride	-	Make adjustments as needed. See Pre-Ride Checklist on page 54.
	Front suspension	-	Pre-Ride	-	
	Rear suspension	-	Pre-Ride	-	
	Tires	-	Pre-Ride	-	
	Brake fluid level	-	Pre-Ride	-	
	Brake lever travel	-	Pre-Ride	-	
	Brake system	-	Pre-Ride	-	
	Passenger seat latch	-	Pre-Ride	-	
	Wheels/fasteners	-	Pre-Ride	-	
	Frame fasteners	-	Pre-Ride	-	
	Engine oil level	-	Pre-Ride	-	
▶ E	Air filter, pre-filter	-	Daily	-	Inspect; clean often; replace as needed
	Coolant	-	Daily	-	Check level daily, change coolant every 2 years
▶	ADC fluid	-	Daily	-	Check level, add as needed
▶	Power steering unit	-	Daily	-	Inspect daily; clean often
	Headlight/taillight	-	Daily	-	Check operation
▶ E	Air filter, main element	-	Weekly	-	Inspect; replace as needed
▶	Engine oil change	20 H	1 Month	500 (800)	Perform break-in oil and filter change (see page 52)
▶ n	Brake pad wear	10 H	Monthly	100 (160)	Inspect periodically
	Battery	20 H	Monthly	200 (320)	Check terminals; clean; test
▶	Rear gearcase oil	25 H	Monthly	250 (400)	Inspect level
▶	Transmission oil	25 H	Monthly	250 (400)	Inspect level
▶	Demand drive fluid	25 H	Monthly	250 (400)	Inspect level
▶	Demand drive fluid (extreme use)	25 H	1 M	250 (400)	Change fluid every 25 hours if ADC is subjected to extreme use. See page 86.
▶	General lubrication	50 H	3 M	500 (800)	Lubricate all fittings, pivots, cables, etc.
	Shift linkage	50 H	6 M	500 (800)	Inspect, lubricate
n	Steering	50 H	6 M	500 (800)	Lubricate
▶	Front suspension	50 H	6 M	500 (800)	Lubricate
▶	Rear suspension	50 H	6 M	500 (800)	Lubricate

▶ Perform these procedures more often for vehicles subjected to severe use.

E Emission-Related Service

n Have an authorized POLARIS dealer perform these services.

MAINTENANCE

Periodic Maintenance Chart

	Item	Maintenance Interval (whichever comes first)			Remarks
		Hours	Calendar	Miles (Km)	
nE	Throttle Cable/ ETC Switch	50 H	6 M	500 (800)	Inspect; adjust; lubricate; replace if necessary
E	Throttle Body Intake Duct	50 H	6 M	500 (800)	Inspect duct for proper seal- ing/air leaks
	Drive belt	50 H	6 M	500 (800)	Inspect; adjust; replace as needed
	Cooling system	50 H	6 M	1000 (1600)	Inspect coolant strength seasonally; pressure test system yearly
▶	Radiator	50 H	6 M	1000 (1600)	Inspect; clean external surfaces
▶	Cooling hoses	50 H	6 M	1000 (1600)	Inspect for leaks
▶	Engine oil change	100 H	6 M	1000 (1600)	Change the oil and filter
▶	Rear gearcase oil	100 H	12 M	1000 (1600)	Change fluid
▶	Transmission oil	100 H	12 M	1000 (1600)	Change fluid
▶	Demand drive fluid (normal use)	100 H	12 M	1000 (1600)	Change fluid
	Fuel system	100 H	12 M	1000 (1600)	Check for leaks at tank cap, lines, filter, pump; replace lines every two years
▶	Engine mounts	100 H	12 M	1000 (1600)	Inspect
	Exhaust muffler/ pipe	100 H	12 M	1000 (1600)	Inspect
nE	Spark plug	100 H	12 M	1000 (1600)	Inspect; replace as needed
▶	Wiring	100 H	12 M	1000 (1600)	Inspect for wear, routing, security; apply dielectric grease to connectors subjected to water, mud, etc.
n	Clutches (drive and driven)	100 H	12 M	1000 (1600)	Inspect; clean; replace worn parts
n	Front wheel bearings	100 H	12 M	1000 (1600)	Inspect; replace as needed
n	Brake fluid	200 H	24 M	2000 (3200)	Change every two years
▶ n	ADC fluid	200 H	24 M	2000 (3200)	Change every two years
	Spark arrestor	300 H	36 M	3000 (4800)	Clean out
nE	Valve clearance	1000 H	-	10000 (16000)	Inspect; adjust
n	Toe adjustment		-		Inspect periodically; adjust when parts are replaced
	Headlight aim		-		Adjust as needed

MAINTENANCE

Lubrication Guide

Check and lubricate all components at the intervals outlined in the Periodic Maintenance Chart beginning on page 76. Items not listed in the chart should be lubricated at the General Lubrication interval.

The a-arms and upper control arms are lubricated at the factory, and no additional lubrication will be needed. However, if these components are subjected to severe use, grease zerks have been provided for additional lubrication at the user's discretion.

Item	Recommended Lubricant	Capacity at Fluid Change	Fill Plug Torque	Drain Plug Torque	Inspection Procedure
550 Engine Oil	PS-4 PLUS Performance Synthetic 2W-50	2 qt. (1.9 l)	---	15-17 ft. lbs. (20-23 Nm)	Page 81.
850 Engine Oil	PS-4 PLUS Performance Synthetic 2W-50	2 qt. (1.9 l)	---	12 ft. lbs. (16 Nm)	Page 81.
Transmission Oil	AGL PLUS Transmission Fluid	32 oz. (946 ml)	10-14 ft. lbs. (14-19 Nm)	10-14 ft. lbs. (14-19 Nm)	Page 84.
Demand Drive Fluid (Front Gearcase)	Demand Drive PLUS Fluid	9.3 oz. (275 ml)	8-10 ft. lbs. (11-14 Nm)	11 ft. lbs. (15 Nm)	Page 86.
Rear Gearcase Oil	ATV Angle Drive Fluid (or GL5 80-90 weight gear lube)	7.1 oz. (210 ml)	10-14 ft. lbs. (14-19 Nm)	10-14 ft. lbs. (14-19 Nm)	Page 89.
Brake Fluid	DOT 4 Only	---	---	---	Page 30.
ADC Fluid	Demand Drive PLUS Fluid	---	---	---	Page 87.
Front Prop Shaft Yoke	POLARIS Premium U-Joint Lube	Grease fittings (3 pumps maximum) every 500 miles, before long periods of storage, or after pressure washing or submerging.			
A-Arms, Front and Rear	POLARIS Premium All-Season Grease	Grease fittings after extreme use or if suspension becomes squeaky.			

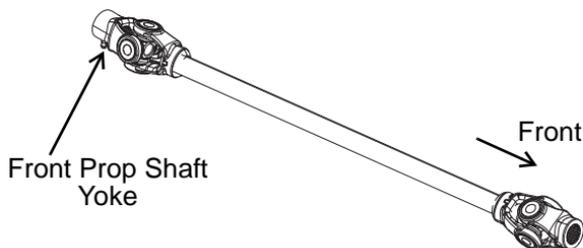

Engine Oil

Oil Recommendations

POLARIS recommends the use of POLARIS PS-4 PLUS Performance Synthetic 2W-50 4-cycle oil or a similar oil for this engine. See the table on page 80 for fluid recommendations, capacities and plug torques.

Oil may need to be changed more frequently if POLARIS oil is not used. Always use 2W-50 oil. Follow the manufacturer's recommendations for ambient temperature operation. See page 131 for the part numbers of POLARIS products.

NOTICE: Mixing brands or using a non-recommended oil may cause serious engine damage. Always use the recommended oil. Never substitute or mix oil brands.

Oil Level

Check the oil level when the engine is cold. *Never check the oil with the engine running.*

1. Position the vehicle on a level surface.
2. Access the oil dipstick and fill tube from the left side of the ATV. Remove the dipstick. Wipe it dry with a clean cloth.
3. Reinstall and tighten the dipstick.
4. Remove the dipstick and check the oil level.
5. Add the recommended fluid as needed. Maintain the oil level in the safe range between the FULL and ADD marks. Do not overfill.
6. Reinstall and tighten the dipstick.

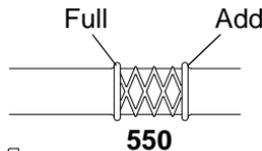
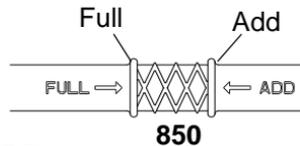
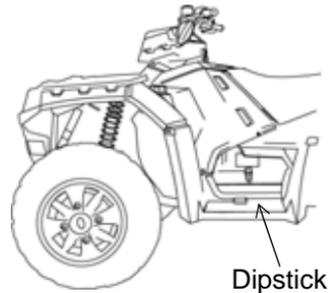

MAINTENANCE

Engine Oil

Oil and Filter Change

See the table on page 80 for fluid recommendations, capacities and plug torques. Always change the oil and filter at the intervals outlined in the Periodic Maintenance Chart beginning on page 76. Always change the oil filter whenever changing oil.

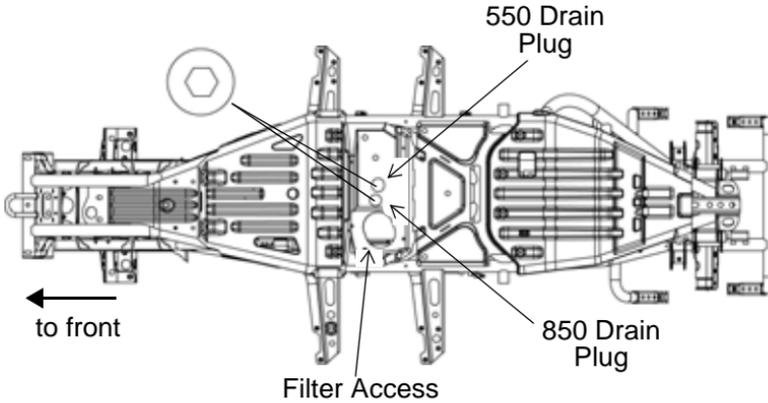

1. Position the vehicle on a level surface.
2. Start the engine. Allow it to warm up at idle for two to three minutes.
3. Stop the engine.
4. Clean the area around the drain plug.
5. Place a drain pan under the crankcase.
6. Remove the drain plug. Allow the oil to drain completely.

CAUTION! Hot oil can cause burns to skin. Do not allow hot oil to contact skin.

7. Install a new sealing washer on the drain plug. The sealing surfaces on drain plug and crankcase should be clean and free of burrs, nicks or scratches.
8. Reinstall the drain plug. Torque to specification.

Engine Oil Oil and Filter Change

9. Place shop towels beneath the oil filter. Using an oil filter wrench (available from your POLARIS dealer), turn the filter counter-clockwise to remove it.
10. Using a clean dry cloth, clean the filter sealing surface on the crankcase.
11. Lubricate the o-ring on the new filter with a film of fresh engine oil. Check to make sure the o-ring is in good condition.
12. Install the new filter and rotate it clockwise by hand until the filter gasket contacts the sealing surface, then turn it an additional 1/2 turn.
13. Remove the dipstick. Add the proper amount of the recommended oil. Do not overfill.
14. Reinstall the dipstick.
15. Place the transmission in PARK.
16. Lock the parking brake.
17. Start the engine. Allow it to idle for one to two minutes.
18. Stop the engine.
19. Check for leaks.
20. Check the oil level. Add oil as needed to bring the level to the upper mark on the dipstick.
21. Dispose of used filter and oil properly.

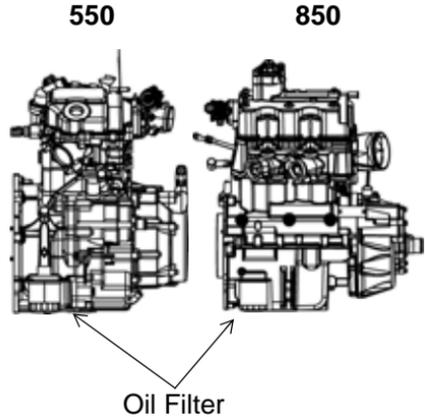

MAINTENANCE

Transmission Oil

POLARIS recommends the use of POLARIS AGL PLUS Transmission Fluid for this transmission. See the table on page 80 for fluid recommendations, capacities and plug torques. Always check and change the transmission oil at the intervals outlined in the Periodic Maintenance Chart beginning on page 76. See page 131 for the part numbers of POLARIS products.

Maintain the oil level at the bottom of the fill plug hole. The fill plug is located on the right side of the ATV behind the footwell. The drain plug is located on the bottom rear side of the gearcase.

Oil Check

1. Remove the footwell (see page 97).
2. Remove the fill plug. Check the oil level.
3. Add the recommended fluid as needed to bring the level to the bottom of the fill hole threads.
4. Reinstall the fill plug. Torque to specification.
5. Reinstall the footwell.

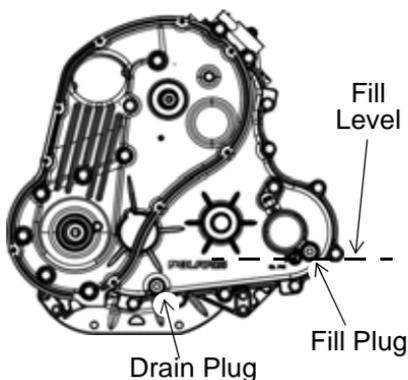

Transmission Oil Oil Change

1. Remove the footwell.
2. Place a drain pan under the gearcase. Remove the drain plug. Allow the oil to drain completely.
3. Clean and reinstall the drain plug. Torque to specification.
4. Remove the fill plug. Add the proper amount of the recommended oil.
5. Reinstall the fill plug. Torque to specification.
6. Check for leaks.
7. Reinstall the footwell.
8. Dispose of used oil properly.

MAINTENANCE

Front Gearcase (Demand Drive) Fluid

See the table on page 80 for fluid recommendations, capacities and plug torques. Always check and change the demand drive fluid at the intervals outlined in the Periodic Maintenance Chart beginning on page 76. See page 131 for the part numbers of POLARIS products.

Change the front gearcase fluid every 25 hours if the ADC unit is exposed to extreme use. Extreme use includes any of the following:

- operation in ADC mode for prolonged periods
- constant ADC operation on hilly or mountainous terrain
- ADC is the primary mode of all-wheel-drive operation

Tip: If the front gearcase makes excessive noise during ADC operation, change the demand drive fluid. If the noise continues, please see your POLARIS dealer for service.

Use the recommended fluid. Use of other fluids may result in improper operation of components. Maintain the fluid level at the bottom of the fill hole threads. The fill plug is located on the right side of the demand drive unit. The drain plug is located on the bottom right side of the unit.

Fluid Check

1. Position the vehicle on a level surface. Remove the fill plug. Check the fluid level.
2. Add the recommended fluid as needed to bring the level to the bottom of the fill hole threads.
3. Reinstall the fill plug. Torque to specification.

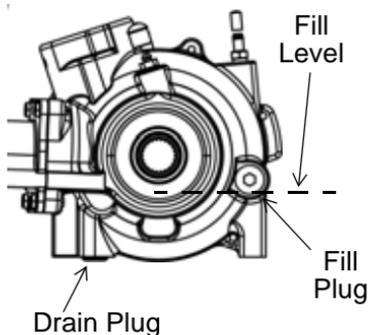

Fluid Change

1. Position the vehicle on a level surface. Remove the fill plug.
2. Place a drain pan under the demand drive unit. Remove the drain plug. Allow the fluid to drain completely.
3. Clean and reinstall the drain plug. Torque to specification.
4. Add the proper amount of the recommended fluid.
5. Reinstall the fill plug. Torque to specification.
6. Check for leaks. Dispose of used fluid properly.

MAINTENANCE

Active Descent Control (ADC) Fluid

Check and change the ADC fluid at the intervals outlined in the Periodic Maintenance Chart beginning on page 76.

We recommend the use of POLARIS Demand Drive Plus Fluid for the ADC unit. Maintain the fluid level between the minimum and maximum marks on the reservoir. See page 131 for the part numbers of POLARIS products.

NOTICE: Do not use brake fluid. Brake fluid will damage rubber components in the hydraulic system.

Fluid Check

1. Access the reservoir under the front box. See page 36.
2. View the fluid level in the reservoir.
3. If the level is below the minimum mark, remove the cap and add the recommended fluid.
4. Reinstall the cap.
5. Close and secure the front box and cover.

ADC Fluid Reservoir



MAINTENANCE

Active Descent Control (ADC) Fluid Fluid Change

1. Position the vehicle on a level surface. Before performing the fluid change, allow the vehicle to sit for at least 30 minutes.
2. Thoroughly clean the areas around and on the ADC reservoir and bleeder valves (one on each side of the differential).
3. Remove the reservoir cap and diaphragm assembly. Use a shop towel or suction tool to remove debris from the fluid and reservoir. Debris in the reservoir may result in inadequate bleeding and reduced performance of the system.

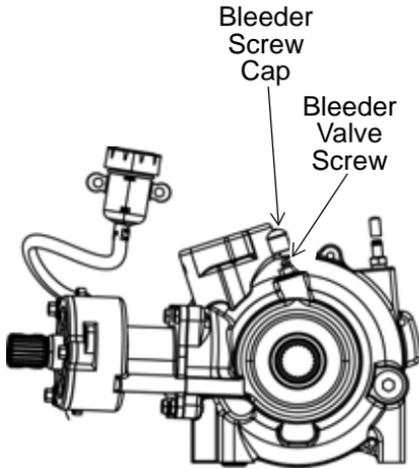

4. Fill the reservoir to the maximum line with fresh fluid.
5. Remove the protective caps from the bleeder valves.
6. Slowly loosen one of the bleeder valve screws (turn counter-clockwise) and allow fluid and trapped air to flow from the fitting. Tighten the screw when clean fluid begins to flow. Repeat this step for the remaining valve.

IMPORTANT: Close the bleeder valve screws before the reservoir fluid level drops below the minimum fill line. Adding fluid to an empty reservoir will result in trapped air. If the level drops below the minimum line, add fluid to the maximum line and repeat step 6 before proceeding.

7. Torque the bleeder valve screws to 80 in. lbs. (9 Nm). Reinstall the bleeder valve caps.
8. Add fresh ADC fluid to the reservoir until the level is between the minimum and maximum marks. Make sure the reservoir is free of debris.
9. Reinstall the cap securely. Clean up any drips or spills.

Rear Gearcase Oil

See the table on page 80 for fluid recommendations, capacities and plug torques. Always check and change the rear gearcase oil at the intervals outlined in the Periodic Maintenance Chart beginning on page 76. See page 131 for the part numbers of POLARIS products.

The fill plug is located on the rear of the gearcase. The drain plug is located on the bottom of the gearcase.

Maintain the fluid level at the bottom of the fill hole threads. Do not overfill.

Oil Check

1. Position the vehicle on a level surface.
2. Remove the fill plug. Check the oil level.
3. Add the recommended oil as needed to bring the level to the bottom of the fill hole threads. *Do not overfill.*
4. Reinstall the fill plug. Torque to specification.

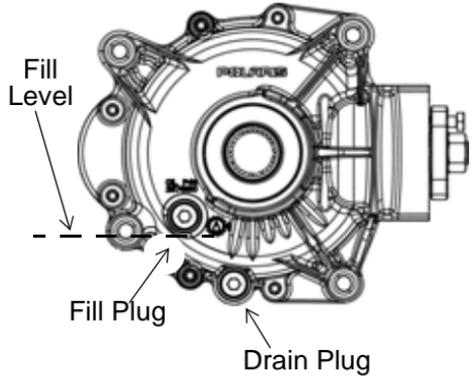

Oil Change

1. Position the vehicle on a level surface.
2. Place a drain pan under the drain hole.
3. Remove the drain plug. Allow the oil to drain completely.
4. Clean and reinstall the drain plug with a new sealing washer. Torque to specification.
5. Remove the fill plug. Add the proper amount of the recommended oil. *Do not overfill.*
6. Reinstall the fill plug. Torque to specification.
7. Check for leaks.
8. Dispose of used oil properly.

MAINTENANCE

Power Steering Unit

If your model is equipped with power steering, frequently clean the areas around and on the power steering unit to allow proper cooling. Clean these areas thoroughly.

Clean
Often



Steering Assembly

The steering assembly of the ATV should be checked periodically for loose nuts and bolts. If loose nuts and bolts are found, see your POLARIS dealer for service before operating the vehicle.

Cooling System

The engine coolant level is controlled, or maintained, by the recovery system. The recovery system components are the recovery bottle, the radiator filler neck, the radiator pressure cap and the connecting hose.

As coolant operating temperature increases, the expanding (heated) excess coolant is forced out of the engine, past the pressure cap, and into the recovery bottle. As engine coolant temperature decreases the contracting (cooled) coolant is drawn back up from the bottle, past the pressure cap, and into the radiator.

Some coolant level drop on new vehicles is normal as the system is purging itself of trapped air. Check the coolant level and maintain as recommended by adding coolant to the recovery bottle.

POLARIS recommends the use of POLARIS Premium 60/40 anti-freeze/coolant or a 50/50 mixture of high quality aluminum compatible anti-freeze/coolant and distilled water. POLARIS Premium 60/40 is already premixed and ready to use. Do not dilute with water. See page 131 for the part numbers of POLARIS products.

Always follow the manufacturer's mixing recommendations for the freeze protection required in your area.

Cooling System Recovery Bottle Coolant

The recovery bottle fluid level can be viewed from inside the front right wheel well. Access the recovery bottle cap under the front box. See page 36.

1. View the fluid level in the bottle.
2. If the level is low, remove the bottle cap and add coolant as needed. Maintain the coolant level between the minimum and maximum marks on the bottle (when the fluid is cool).
3. Reinstall the cap.
4. Close and secure the front box and cover.

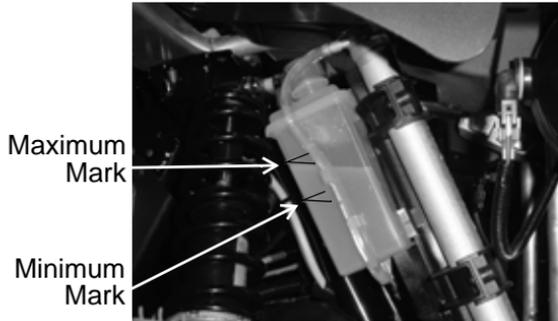

Recovery
Bottle Cap

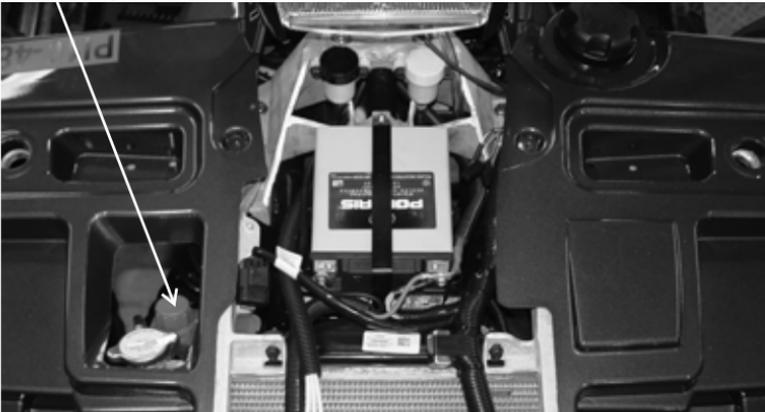

MAINTENANCE

Cooling System

Radiator Coolant

To ensure that the coolant maintains its ability to protect the engine, POLARIS recommends that you drain the system completely every two years and add a fresh mixture of antifreeze and water.

Replace the coolant any time the cooling system has been drained for maintenance or repair. If the recovery bottle has run dry, check the level in the radiator. Add coolant as needed.

CAUTION! Escaping steam can cause burns. Never remove the pressure cap while the engine is warm or hot. Always allow the engine to cool before removing the pressure cap.

1. Access the pressure cap under the front box. See page 36.
2. Remove the pressure cap.
3. Using a funnel, slowly add coolant through the radiator filler neck.
4. Reinstall the pressure cap. Use of a non-standard pressure cap will not allow the recovery system to function properly. Contact your dealer for the correct replacement part.
5. Close and secure the front box and cover.



Radiator
Cap

Brakes

Hand Brake

The front and rear brakes are hydraulic disc brakes, activated by moving the single brake lever toward the handlebar. These brakes are self-adjusting.

Under normal operation, the diaphragm extends into the reservoir as fluid level drops. If the fluid level is low and the diaphragm is not extended, a leak is likely and the diaphragm should be replaced. To ensure proper diaphragm operation, always fill the reservoir as needed whenever the cover is loosened or removed. Do not overfill.

WARNING! An over-full master cylinder may cause brake drag or brake lock-up, which could result in serious injury or death. Maintain brake fluid at the recommended level. Do not overfill.

The following checks are recommended to keep the brake system in good operating condition. Check more often if brakes are used heavily under normal operation.

1. Always keep brake fluid at an adequate level. See page 30.
2. Check the brake system for fluid leaks.
3. Check the brakes for excessive travel or spongy feel.
4. Check the friction pads for wear, damage and looseness. Replace brake pads when they are worn to $3/64"$ (1 mm).
5. Check the security and surface condition of the disc.

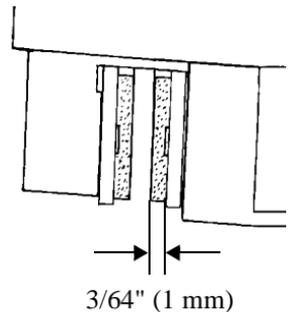

Auxiliary Foot Brake

The hydraulic auxiliary brake system requires no adjustment. Check the brake fluid level frequently for the auxiliary brake system. See page 32.

MAINTENANCE

Toe Alignment

Use the following procedure to check the toe alignment of the vehicle. The recommended toe alignment is 0" to 1/8" (0-3 mm).

WARNING! Severe injury or death can result from improper toe alignment and adjustment. Do not attempt to adjust tie rod alignment. All tie rod adjustments should be performed by an authorized POLARIS dealer.

1. Position the vehicle on a level surface.
2. Place the handlebars in a straight-ahead position.
3. Tie a length of string between two stands as shown in the illustration. Position the stands so that the string is flush with the side of the rear tire. If available, you may use a long straight-edge instead of string.
4. Measure the distance from the string to the rim at the front (1) and rear (2) of the front rim.

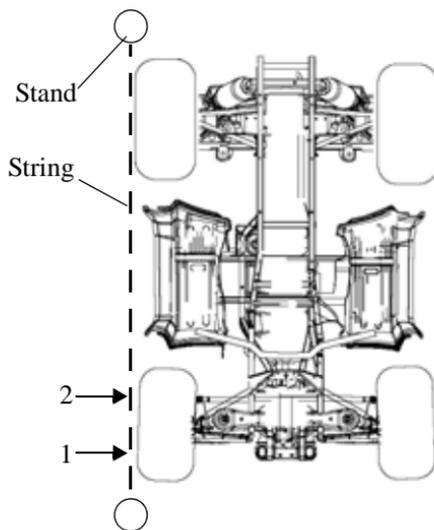

The rear measurement should be 1.5 mm more than the front measurement on each side of the vehicle to obtain the recommended 0" to 1/8" (0-3 mm) toe out alignment.

5. Repeat the measurement procedure on the other side of the vehicle.
6. If you discover improper alignment, see your POLARIS dealer for service.

Seats

Passenger Seat Removal

1. Pull the latch at the rear of the seat.
2. Pivot the rear of the seat upward and remove the front legs of the seat base from the frame.
3. To reinstall the seat, position the front legs of the seat base under the frame. Pivot the rear of the seat downward onto the latch. Press down firmly on the seat pad until the latch clicks. Test the seat latch by attempting to pull the seat upward.



Passenger Seat Backrest Adjustments

The passenger backrest can be adjusted horizontally and vertically.

1. Unzip the two zippers at the bottom of the backrest pad. Lift the pad upward to remove it from the backrest frame.
2. To adjust the backrest forward or rearward, loosen the top adjuster bolt. Pivot the adjuster forward or rearward to one of the three adjustment positions and tighten the bolt.
3. To adjust the backrest upward or downward, loosen the four vertical adjustment screws on the front side of the backrest frame. Slide the backrest upward or downward to the desired position and tighten the screws.
4. Reinstall the backrest pad.



MAINTENANCE

Seats

Passenger Seat Suspension

1. Remove the passenger seat.
2. Remove the fastener retaining the passenger seat shock to the passenger seat support.
3. Pivot the seat support upward to access the lower shock fastener. Remove the lower shock fastener.
4. Remove the shock from the vehicle. If adjustment is necessary, use a suitable pliers or spanner wrench. Adjust the shock to the desired spring preload. Rotate the adjustment cam to the left to increase preload.
5. Reinstall the shock.
6. Torque the upper and lower shock fasteners to 38 ft. lbs. (51 Nm).
7. Reinstall the passenger seat.

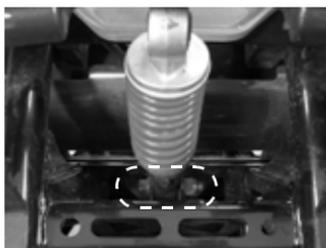
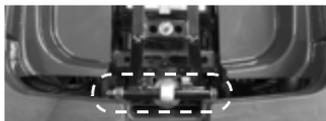

Operator Seat Removal

1. Remove the passenger seat. See page 95.
2. Grasp one side of the operator's seat near the rear edge.
3. Pull upward abruptly to disengage the under-seat fasteners.
4. Remove the seat.



Side Panel/Footwell Removal

1. Remove the seat before removing a side panel.
2. To remove a side panel or footwell, remove the fasteners securing it to the frame. Lift the right side panel upward while removing it to clear the shifter knob

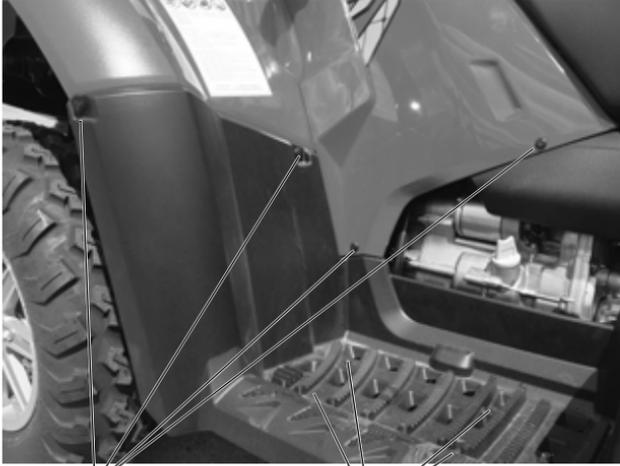

Plastic Rivet

Hex Head Screw



Plastic Rivet

MAINTENANCE

Tires

⚠ WARNING

Operating your ATV with worn tires, improperly inflated tires, non-standard tires or improperly installed tires will affect vehicle handling and could cause an accident resulting in serious injury or death. Always follow all tire maintenance procedures as outlined in this manual and on the labels on the vehicle. Always use original equipment size and type when replacing tires.

Refer to the specifications section beginning on page 132 for recommended tire type, size and pressure.

Tire Tread Depth

Always replace tires when tread depth is worn to 1/8" (3 mm) or less.

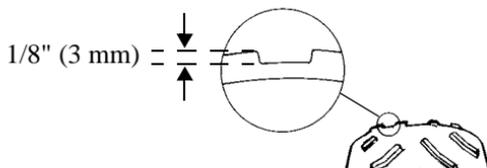

Tires

Front Wheel Hub Tightening

Front wheel bearing tightness and spindle nut retention are critical component operations. All service must be performed by your authorized POLARIS dealer.

Wheel Removal

1. Stop the engine.
2. Place the transmission in PARK.
3. Lock the parking brake.
4. Loosen the wheel nuts slightly.

WARNING! Do not service axle nuts that have a cotter pin installed. See your POLARIS dealer.

5. Elevate the side of the vehicle by placing a suitable stand under the footrest frame.
6. Remove the wheel nuts.
7. Remove the wheel.

MAINTENANCE

Tires

Wheel Installation

1. Place the transmission in PARK.
2. Lock the parking brake.
3. Place the wheel on the hub with the valve stem toward the outside and rotation arrows on the tire pointing toward forward rotation.
4. Install the wheel nuts and finger-tighten them.
5. Lower the vehicle to the ground.
6. Torque the wheel nuts to specification.

WARNING! Loose nuts could cause a tire to come off during operation, which could result in an accident or overturn. Always ensure that all nuts are torqued to specification.



75 ft. lbs.
(102 Nm)

Cast Aluminum



45 ft. lbs.
(61 Nm)

Steel

Wheel Nut Torque Specifications

Check the wheel nut torques occasionally and when they've been loosened for service.

Wheel Type	Nut Type	Nut Torque
Aluminum	Lug Nut	75 ft. lbs. (102 Nm)
Steel	Lug Nut	45 ft. lbs. (61 Nm)

Air Filter

1. Remove the seat.
2. Remove the air box cover screws, and remove the air box cover.
3. Remove the filter.
4. Remove the fabric type pre-filter from the main filter. Wash the pre-filter in soapy water, then rinse and let dry.
5. Reinstall the pre-filter over the main filter. Install a new main filter if needed.
6. Reinstall the filter into the air box.
7. Reinstall the air box cover and the seat.

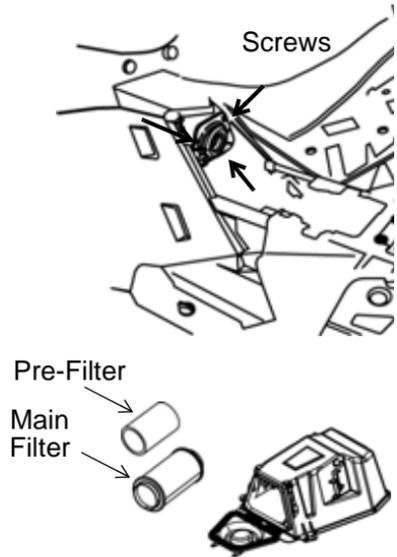

MAINTENANCE

Fuse Replacement

If the engine stops or will not start, or if you experience other electrical failures, a fuse may need replacement. Locate and correct any short circuits that may have caused the blown fuse, then replace the fuse. Spare fuses are provided in the fuse box.

1. Access the fuses under the front box. See page 36.
2. Remove the fuse box cover.
3. Remove the suspect fuse from the fuse panel. If the fuse is blown, install a new fuse with the same amperage rating.
4. Reinstall the fuse box cover.
5. Close and secure the front box and cover.



Fuse Box

ECU RELAY	FAN RELAY	EFI RELAY	BUMPER LIGHTS RELAY	SPARE
			WIRES →	
CHASSIS RELAY	LIGHTS 20A	DRIVE 20A	ACCESSORY 20A	SPARE
	EFI 20A	UNSWITCH 10A	EPAS 30A	

550

START SOLENOID RELAY	FAN RELAY	EFI RELAY	BUMPER LIGHTS RELAY	SPARE
			WIRES →	
CHASSIS RELAY	LIGHTS 20A	DRIVE 20A	ACCESSORY 20A	SPARE
	EFI 20A	UNSWITCH 10A	EPAS 30A	

850

Lights

Poor lighting can result in reduced visibility when driving. Headlight and taillight lenses become dirty during normal operation. Clean headlights frequently and replace burned out headlamps promptly. Always make sure lights are adjusted properly for best visibility.

Headlight Lamp Replacement

When servicing a halogen lamp, avoid touching the lamp with bare fingers. Oil from your skin leaves a residue, causing a hot spot that will shorten the life of the lamp. If fingers do touch a lamp, clean it with denatured alcohol.

1. Remove the five (5) headlight pod screws.
2. Lift the pod cover and disconnect the speedometer harnesses from the speedometer.

CAUTION! Hot components can cause burns to skin. Allow lamps to cool before servicing.

3. Unplug the headlamp from the wiring harness. Be sure to pull on the connector, not on the wiring.
4. Turn the lamp counter-clockwise to remove it.
5. Install the new lamp. Make sure the tab on the lamp locates properly in the housing.
6. Reassemble the pod.

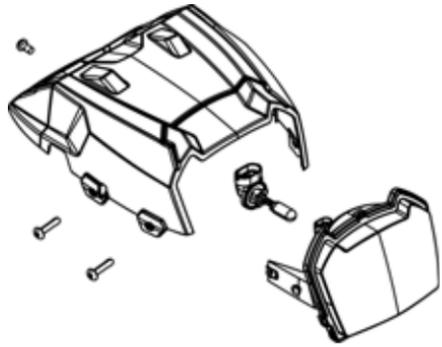

MAINTENANCE

Lights

High Beam Adjustment

The headlight beam can be adjusted slightly upward or downward. Use the following procedure to make the adjustment.

1. Position the vehicle on a level surface with the headlight approximately 25 ft. (7.6 m) from a wall. Place the transmission in PARK.

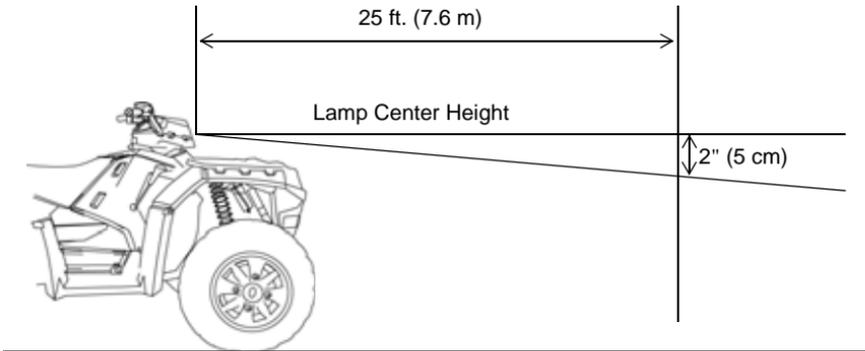

2. Measure the distance from the floor to the center of the headlight and make a mark on the wall at the same height.
3. Start the engine. Turn the headlight switch to high beam.
4. Observe the headlight aim on the wall. The most intense part of the headlight beam should be two inches (5 cm) below the mark on the wall. Include rider weight on the seat when measuring.
5. The adjustment knob is located on the right side of the headlight pod. Adjust the beam to the desired position by turning the knob either clockwise or counter-clockwise.

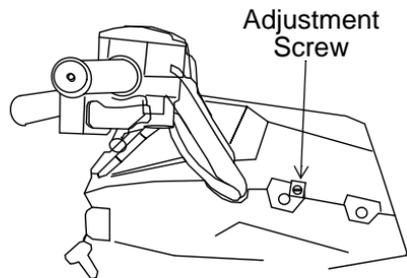

Lights

Low Beam Adjustment

The low beam can be adjusted slightly upward or downward.

1. Loosen the phillips screw located at the rear of the headlamp.
2. Tilt the headlamp upward or downward.
3. Tighten the screw.

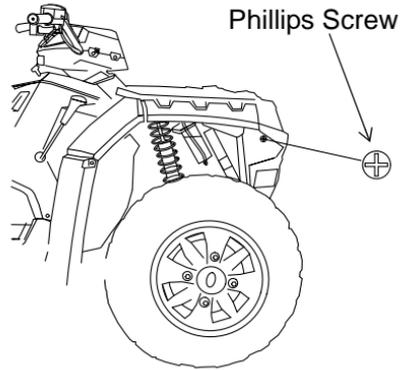

MAINTENANCE

Lights

Headlight Housing Replacement

1. Remove the five (5) headlight pod screws.
2. Lift the pod cover and disconnect the speedometer harnesses from the speedometer.
3. Unplug the headlamp from the wiring harness.
4. Use a small screwdriver to remove the o-rings from the headlight mounting tabs.
5. Pull the headlight housing up to release it from the locking tabs.
6. Carefully pull the assembly up and out of the pod.
7. Reverse the steps to install the new housing and reassemble the pod.

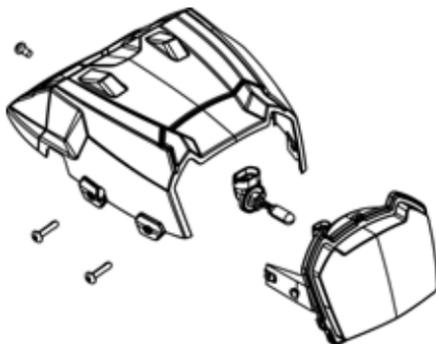

Lights

Lower Headlamp Replacement

1. Turn the back of the headlight harness counter-clockwise and pull the harness assembly away from the headlight assembly.
2. Remove the headlamp and install the new headlamp.
3. Reinstall the harness assembly into the headlight assembly.
4. Turn the headlight harness clockwise to secure the headlamp.

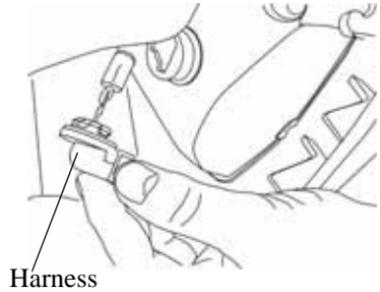

Taillight/Brakelight Lamp Replacement

1. Remove the harness connector from the back of the light assembly.
2. Turn the lamp counter-clockwise to remove it.
3. Install the new lamp.
4. Reinstall the harness connector.
5. Test the light for proper operation.

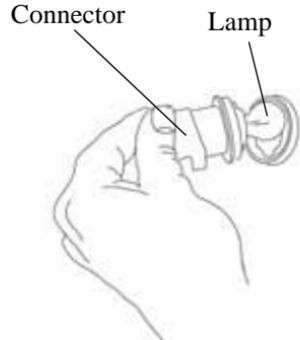

MAINTENANCE

Spark Plugs

Spark Plug Recommendations

Refer to the specifications section beginning on page 132 for the recommended spark plug type and gap for your vehicle. Torque spark plugs to specification.

NOTICE: Using non-recommended spark plugs can result in serious engine damage. Always use POLARIS-recommended spark plugs.

Plug Condition	Torque Specification	
	550	850
New Spark Plug	9-11 ft. lbs. (12-15 Nm)	18-20 ft. lbs. (24-27 Nm)
Previously Installed Spark Plug	17-20 ft. lbs. (23-27 Nm)	18-20 ft. lbs. (24-27 Nm)

Spark Plug Inspection

Spark plug condition is indicative of engine operation. Check the spark plug firing end condition after the engine has been warmed up and the vehicle has been driven at higher speeds. Immediately check the spark plug for correct color. See page 109.

CAUTION! A hot exhaust system and engine can cause burns. Wear protective gloves when removing a spark plug for inspection.

1. Rotate the spark plug cap 1/4 turn and pull it off the spark plug.
2. Rotate the spark plug counter-clockwise to remove it.
3. Reverse the procedure for spark plug installation. Torque to specification.

Spark Plugs

Spark Plug Inspection

Normal Spark Plug

The normal insulator tip is gray, tan or light brown. There will be few combustion deposits. The electrodes are not burned or eroded. This indicates the proper type and heat range for the engine and the service.

The tip should not be flaky and white. A white insulator tip indicates overheating, caused by use of an improper spark plug or incorrect fuel.

Wet Fouled Spark Plug

The wet fouled insulator tip is black. A damp oil film covers the firing end. There may be a carbon layer over the entire nose. Generally, the electrodes are not worn. General causes of fouling are excessive oil, use of non-recommended oil or incorrect throttle body adjustments.

MAINTENANCE

Vehicle Immersion

If your vehicle becomes immersed, major engine damage can result if the machine is not thoroughly inspected. Take the vehicle to your dealer before starting the engine. If it's impossible to take your ATV to a dealer before starting it, follow the steps outlined below.

1. Move the ATV to dry land or at the very least, to water below the footrests.
2. Check the air box. If water is present, dry the air box and replace the filter with a new filter.
3. Remove the spark plug.
4. Turn the engine over several times using the electric start.
5. Dry the spark plugs. Reinstall the plugs or install new plugs.
6. Attempt to start the engine. If necessary, repeat the drying procedure.

NOTICE: Serious damage can occur after immersion if fluids are not changed promptly. See your dealer as recommended.

7. Take the ATV to your dealer for service as soon as possible, whether you succeed in starting it or not.
8. If water has been ingested into the PVT, follow the procedure on page 114 for drying out the PVT.

Spark Arrestor

▲ WARNING

Failure to heed the following warnings while servicing the spark arrestor could result in serious injury or death. Never run the engine in an enclosed area. Remove any combustible materials from the area. Wear eye protection and leather work gloves. Do not stand behind or in front of the vehicle while purging. Never go under the vehicle while it's inclined.

The exhaust system can get extremely hot. Do not perform service on the spark arrestor while the system is hot. Allow components to cool sufficiently before proceeding.

Use the following procedure to periodically purge accumulated carbon from the exhaust pipe/muffler.

1. Remove the arrestor clean-out plug from the bottom of the muffler.
2. Place the transmission in PARK.
3. Start the engine.
4. Quickly squeeze and release the throttle lever several times to purge carbon from the system.
5. If carbon comes out of the exhaust, cover or plug the exhaust outlet(s). Wear protective gloves.
6. Lightly tap on the exhaust pipe with a rubber mallet while repeating step 4.
7. If particles are still suspected to be in the muffler, elevate the rear of the vehicle one foot (30 cm) higher than the front. Block the wheels.
8. Repeat steps 4 to 6 until no more particles are expelled.
9. Stop the engine. Allow the arrestor to cool.
10. Reinstall the arrestor plug and remove the exhaust outlet cover or plug.

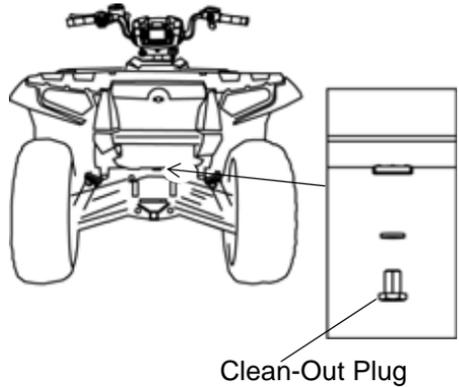

MAINTENANCE

PVT System

WARNING

Failure to comply with the instructions in this warning can result in severe injury or death.

Do not modify any component of the PVT system. Doing so may reduce its strength so that a failure may occur at a high speed. The PVT system has been precision balanced. Any modification will cause the system to be out of balance, creating vibration and additional loads on components.

The PVT system rotates at high speeds, creating large amounts of force on clutch components. Extensive engineering and testing has been conducted to ensure the safety of this product. However, as the owner, you have the following responsibilities to make sure this system remains safe:

- Always follow all recommended maintenance procedures. See your dealer as outlined in the owner's manual.
- This PVT system is intended for use on POLARIS products only. Do not install it in any other product.
- Always make sure the PVT housing is securely in place during operation.

PVT System

The basic operation of the POLARIS PVT system is dependent on engine speed and vehicle torque requirements. As engine speed increases, the force exerted on the movable drive sheave by the flyweights also increases. This, in turn, increases the amount of pinch applied to the drive belt. Similarly, if the engine speed decreases, the amount of centrifugal force decreases, reducing the amount of belt pinch.

On POLARIS ATVs, the approximate gear ratio difference between high and low range is 1:2.25. This difference in gearing affects the operation of the PVT, especially at speeds less than 7 MPH (11 km/h), due to the system's dependence on engine speed.

For example, when operating at a ground speed of 3 MPH (5 km/h) in low range, the engine speed would be around 3000 RPM. This is well above the engagement speed of 1600 - 1800 RPM. However, in high range at 3 MPH (5 km/h), the engine would be running at only 1500 RPM. Whenever operating this close to the engagement speed, the engine may be running at a speed too low to provide the pinch needed to prevent belt slip. Belt slip is responsible for creating the excessive heat that destroys belts, wears clutch components and causes outer clutch covers to fail.

The air temperature in the clutch cover is substantially reduced by using low range while operating at low ground speeds. Reducing the temperature inside the clutch cover greatly extends the life of the PVT components (belt, cover, etc.).

MAINTENANCE

PVT System

When To Use Low Range and High Range

Condition	Range to Use
Operating at speeds less than 7 MPH (11 km/h)	Low
Towing heavy loads	Low
Operating in rough terrain (swamps, mountains, etc.)	Low
Operating at speeds greater than 7 MPH (11 km/h)	High

PVT Drying

There may be some instances when water is accidentally ingested into the PVT system. Use the following instructions to dry it out before operating.

1. Position the vehicle on a level surface.
2. Remove the drain plug. Allow the water to drain completely. Reinstall the drain plug.
3. Start the engine. Place the transmission in PARK.
4. Apply varying throttle for 10-15 seconds to expel the moisture and air-dry the belt and clutches. Do not hold the throttle wide open for more than 5 seconds.
5. Allow the engine RPM to settle to idle speed, then shift the transmission to low range.
6. Test for belt slippage. If the belt slips, repeat the process.
7. Take the vehicle to your dealer for service as soon as possible.

Battery

WARNING

Improperly connecting or disconnecting battery cables can result in an explosion and cause serious injury or death. When removing the battery, always disconnect the negative (black) cable first. When reinstalling the battery, always connect the negative (black) cable last.

Your ATV is equipped with a sealed battery, which requires little maintenance. POLARIS does not recommend using a conventional battery in this vehicle. The orientation of the battery could result in electrolyte leakage, which would shorten the life of the battery considerably.

Always keep battery terminals and connections free of corrosion. If cleaning is necessary, remove corrosion with a stiff wire brush. Wash with a solution of one tablespoon baking soda and one cup water. Rinse well with tap water and dry off with clean shop towels. Coat the terminals with dielectric grease or petroleum jelly.

Battery Removal

1. Access the battery under the front box. See page 36.
2. Disconnect the black (negative) battery cable first.
3. Disconnect the red (positive) battery cable last.
4. Disconnect the battery hold-down strap.
5. Lift the battery out of the ATV.

MAINTENANCE

Battery

Battery Installation

Using a new battery that has not been fully charged can damage the battery and result in a shorter life. It can also hinder vehicle performance. Follow the battery charging instructions on page 117 before installing the battery.

1. Ensure that the battery is fully charged.
2. Place the battery in the battery holder.
3. Coat the terminals with dielectric grease or petroleum jelly.
4. Secure the battery hold-down strap.
5. Connect and tighten the red (positive) cable first.
6. Connect and tighten the black (negative) cable last.
7. Verify that cables are properly routed. Cables should be safely tucked away at the front and rear of the battery.
8. Close and secure the front box and cover.

Battery Storage

Whenever the vehicle is not used for a period of three months or more, remove the battery from the vehicle, ensure that it's fully charged, and store it out of the sun in a cool, dry place. Check battery voltage each month during storage and recharge as needed to maintain a full charge.

POLARIS recommends maintaining battery charge by using a POLARIS Battery Tender charger or by charging about once a month to make up for normal self-discharge. Battery Tender can be left connected during the storage period, and will automatically charge the battery if the voltage drops below a pre-determined point. See page 131 for the part numbers of POLARIS products.

Battery

Battery Charging

The following battery charging instructions apply only to the installation of a sealed battery. Read all instructions before proceeding with the installation of this battery.

The sealed battery is already filled with electrolyte and has been sealed and *fully charged* at the factory. *Never* pry the sealing strip off or add any other fluid to this battery.

The single most important thing about maintaining a sealed battery is to keep it fully charged. Since the battery is sealed and the sealing strip cannot be removed, you must use a voltmeter or multimeter to measure DC voltage.

WARNING! An overheated battery may explode, causing severe injury or death. Always watch charging times carefully. Stop charging if the battery becomes very warm to the touch. Allow it to cool before resuming charging.

For a refresh charge, follow all instructions carefully.

1. The battery should be disconnected from a load or charger for at least two hours before checking voltage. Check the battery voltage with a voltmeter or multimeter. A fully charged battery will register 12.8 V or higher.
2. If the voltage is less than 12.8 volts, recharge the battery at 1.2 amps or less until battery voltage is 12.8 or greater.
3. When using an automatic charger, refer to the charger manufacturer's instructions for recharging. When using a constant current charger, use the guidelines on the next page for recharging.

MAINTENANCE

Battery

Battery Charging (Sealed Battery)

Always verify battery condition before and 1-2 hours after the end of charging.

State of Charge	Voltage	Action	Charge Time (Using constant current charger @ standard amps specified on top of battery)
100%	12.8-13.0 volts	None, check at 3 mos. from date of manufacture	None required
75%-100%	12.5-12.8 volts	May need slight charge, if no charge given, check in 3 months	3-6 hours
50%-75%	12.0-12.5 volts	Needs charge	5-11 hours
25%-50%	11.5-12.0 volts	Needs charge	At least 13 hours, verify state of charge
0%-25%	11.5 volts or less	Needs charge with desulfating charger	At least 20 hours

Camber and Caster

The camber and caster are non-adjustable.

Rear Spring

The rear shock absorber spring is adjusted by rotating the adjuster either clockwise or counter-clockwise to increase or decrease spring tension. Accessory springs are available through your POLARIS dealer.

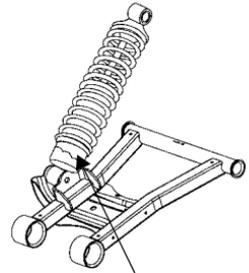

Adjuster

Handlebars

The handlebars can be adjusted for rider preference.

WARNING! Improper adjustment of the handlebars or incorrect torquing of the adjuster block tightening bolts can cause limited steering or loosening of the handlebars, resulting in loss of control and serious injury or death. Follow the adjustment procedures exactly, or see your POLARIS dealer for service.

1. Remove the upper headlight pod.
2. Loosen the four handlebar bolts.
3. Adjust the handlebar to the desired height. Be sure the handlebars do not contact the gas tank or any other part of the machine when turned fully to the left or right.
4. Torque the front two bolts to 10-12 ft. lbs. (14-17 Nm), then torque the rear two bolts. A gap of up to 1/8" (3 mm) will remain at the rear of the clamp blocks.

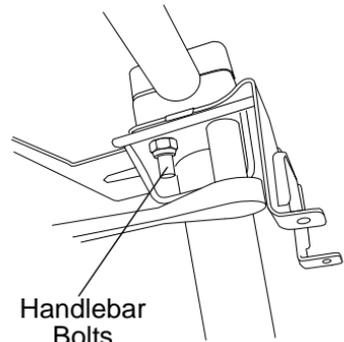

Handlebar Bolts

MAINTENANCE

Throttle Body/Idle RPM

Idle RPM is preset by the manufacturer. If the engine idle speed is not satisfactory, please see your POLARIS dealer for adjustment.

Throttle Cable Freeplay

1. Remove the four cover screws from the right handlebar control and remove the cover.
2. With the handlebars straight ahead, place very light pressure on the throttle lever. A gap of 2-3 mm should be visible between the throttle arm stop pin and the throttle arm.

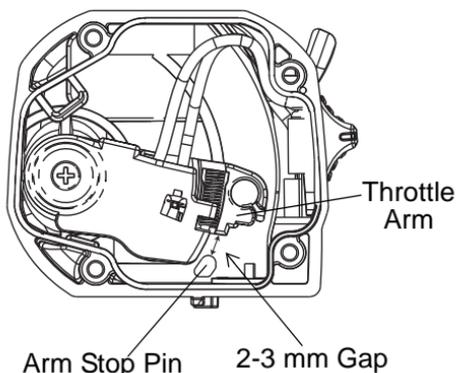

If adjustment is needed:

1. Locate the throttle cable adjuster. Squeeze the end of the rubber boot and slide it back far enough to expose the inline cable adjuster locknut.
2. Loosen the adjuster lock nut.
3. Rotate the boot to turn the adjuster until 2-3 mm of freeplay is achieved between the stop pin and the throttle arm. *While adjusting freeplay, flip the throttle lever back and forth repeatedly.*

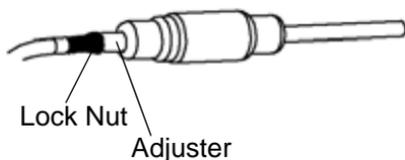
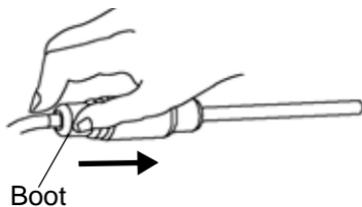
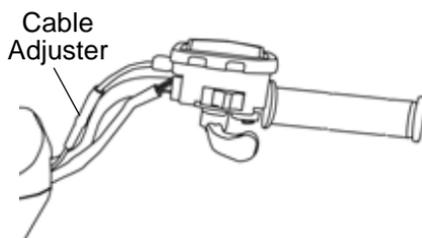

(continued on next page)

Throttle Cable Freeplay

4. Place the transmission in PARK. Lock the parking brake.
5. Start the engine and allow the idle to stabilize. If necessary, tap the throttle lever to ensure the idle speed settles.
6. If idle speed remains above or below the recommended setting (see specification pages), verify the correct gap. If gap is correct and idle speed is still not satisfactory, please see your POLARIS dealer for service.
7. With the engine running, turn the handlebars fully to the left and right. Tap the throttle lever at each turn, verifying that idle RPM returns to the recommended setting. If idle speed increases, it may be necessary to increase the gap between the stop pin and throttle arm, but do not exceed the recommended 2-3 mm gap.
8. When adjustments are complete, tighten the locknut.
9. Squeeze the end of the rubber boot and slide it over the cable adjuster to its original position.
10. Ensure the control cover seal is in place, then reinstall the cover and screws.

MAINTENANCE

Cleaning and Storage

Washing the Vehicle

Keeping your POLARIS vehicle clean will not only improve its appearance but it can also extend the life of various components.

NOTICE: High water pressure may damage components. POLARIS recommends washing the vehicle by hand or with a garden hose, using mild soap.

Certain products, including insect repellents and chemicals, will damage plastic surfaces. Do not allow these types of products to contact the vehicle.

The best and safest way to clean your POLARIS vehicle is with a garden hose and a pail of mild soap and water.

1. Use a professional-type washing cloth, cleaning the upper body first and the lower parts last.
2. Rinse with clean water frequently.
3. Dry surfaces with a chamois to prevent water spots.

Washing Tips

- Avoid the use of harsh cleaners, which can scratch the finish.
- Do not use a power washer to clean the vehicle.
- Do not use medium to heavy duty compounds on the finish.
- Always use clean cloths and pads for cleaning and polishing. Old or reused cloths and pads may contain dirt particles that will scratch the finish.

Cleaning and Storage

Washing the Vehicle

If a high pressure water system is used for cleaning (not recommended), exercise extreme caution. The water may damage components and could remove paint and decals. Avoid directing the water stream at the following items:

- Wheel bearings
- Radiator
- Transmission seals
- Cab and body panels
- Electrical components
- Switches and controls
- Fuel system components
- Labels and decals

If an informational or graphic label becomes illegible or comes off, contact your POLARIS dealer to purchase a replacement. Replacement *safety* labels are provided by POLARIS at no charge.

Grease all zerk fittings immediately after washing. Allow the engine to run for a while to evaporate any water that may have entered the engine or exhaust system.

Polishing the Vehicle

POLARIS recommends the use of common household aerosol furniture polish for polishing the finish on your POLARIS vehicle. Follow the instructions on the container.

Polishing Tips

- Avoid the use of automotive products, some of which can scratch the finish of your vehicle.
- Always use clean cloths and pads for cleaning and polishing. Old or reused cloths and pads may contain dirt particles that will scratch the finish.

MAINTENANCE

Cleaning and Storage

Storage Tips

NOTICE: Starting the engine during the storage period will disturb the protective film created by fogging and damage could occur. Never start the engine during the storage period.

Clean the Exterior

Make any necessary repairs and clean the vehicle as recommended. See page 122.

Stabilize the Fuel

1. Fill the fuel tank.
2. Add POLARIS Carbon Clean Fuel Treatment or POLARIS Fuel Stabilizer. Follow the instructions on the container for the recommended amount. Carbon Clean removes water from fuel systems, stabilizes fuel and removes carbon deposits from pistons, rings, valves and exhaust systems.
3. Allow the engine to run for 15-20 minutes to allow the stabilizer to disperse through the entire fuel delivery system.

Oil and Filter

Change the oil and filter. See page 82.

Air Filter / Air Box

1. Inspect and clean (or replace) the pre-cleaner and air filter. See page 101.
2. Clean the air box.

Fluid Levels

Inspect the fluid levels. Add or change fluids as recommended in the Periodic Maintenance Chart beginning on page 76.

- Demand drive unit (front gearcase)
- ADC fluid (ADC models) (change every two years)
- Rear gearcase
- Transmission
- Brake fluid (change every two years and any time the fluid looks dark or contaminated)
- Coolant (test strength/fill)

Cleaning and Storage

Storage Tips

Fog the Engine

1. After stabilizing the fuel, remove the spark plug and add 2-3 tablespoons of engine oil. To access the plug hole, use a section of clear 1/4" hose and a small plastic squeeze bottle filled with the pre-measured amount of oil.
2. Reinstall the spark plug. Torque to specification.
3. Apply dielectric grease to the inside of each spark plug cap and reinstall the caps onto the plugs.
4. Turn the engine over several times using electric start. Oil will be forced in and around the piston rings and ring lands, coating the cylinder with a protective film of fresh oil.
5. If POLARIS fuel system additive is not used, the fuel tank, fuel lines, and injectors should be completely drained of gasoline.

Inspect and Lubricate

Inspect all cables and lubricate all areas of the vehicle as recommended in the Periodic Maintenance Chart beginning on page 76.

Battery Storage

See pages 116-117 for storage and charging procedures. Store the battery in a cool, dry place.

Storage Area/Covers

Set the tire pressure and safely support the ATV with the tires slightly off the ground. Be sure the storage area is well ventilated. Cover the vehicle with a genuine POLARIS cover. Do not use plastic or coated materials. They do not allow enough ventilation to prevent condensation, and may promote corrosion and oxidation.

MAINTENANCE

Cleaning and Storage Accessories

Auxiliary power outlets provide 12-volt power for operating accessories. Accessory outlets are available for all models. POLARIS also has a wide range of additional accessories available for your ATV. Always install accessories that are approved for ATV use. Please see your POLARIS dealer.

Transporting the ATV

Follow these procedures when transporting the vehicle.

1. Stop the engine.
2. Place the transmission in PARK.
3. Lock the parking brake.
4. Secure the fuel cap, oil cap and seats.
5. Always tie the frame of the ATV to the transporting unit securely with suitable straps or rope. Do not attach tie straps to the front A-arm bolt pockets, racks or handlebars.
6. Remove the key to prevent loss during transporting.

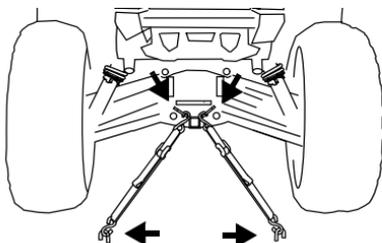
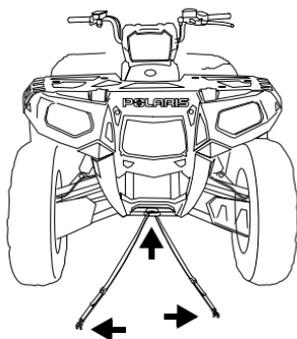

TROUBLESHOOTING

Drive Belt Wear/Burn

Possible Cause	Solution
Driving onto a pickup or tall trailer in high range	Use low range during loading.
Starting out going up a steep incline	Use low range or turn around using the K-turn (see page 66).
Driving at low RPM or ground speed (3-7 MPH)	Drive at a higher speed or use low range more frequently. See page 114.
Insufficient warm-up at low ambient temperatures	Warm the engine at least 5 minutes. With the transmission in neutral, advance the throttle to about 1/8 throttle in short bursts, 5 to 7 times. The belt will become more flexible and prevent belt burning.
Slow/easy clutch engagement	Use the throttle quickly and effectively.
Towing/pushing at low RPM/low ground speed	Use low range only.
Utility use/plowing	Use low range only.
Stuck in mud or snow	Shift the transmission to low range and carefully use fast, aggressive throttle application to engage clutch. WARNING! Excessive throttle may cause loss of control and vehicle overturn.
Climbing over large objects from a stopped position	Shift the transmission to low range and carefully use fast, brief, aggressive throttle application to engage clutch. WARNING! Excessive throttle may cause loss of control and vehicle overturn.
Belt slippage from water or snow ingestion into the PVT system	Dry out the PVT. See page 114. Inspect clutch seals for damage if repeated leaking occurs.
Clutch malfunction	See your POLARIS dealer.
Poor engine performance	Check for fouled plugs or foreign material in gas tank or fuel lines. See your dealer.
Slippage from failure to warm up belt	Always warm up the belt by operating below 30 mph for one mile (5 miles or more when temperature is below freezing).
Wrong or missing belt	Install the recommended belt.
Improper break-in	Always break in a new belt and/or clutch. See page 53.

TROUBLESHOOTING

Engine Doesn't Turn Over

Possible Cause	Solution
Low battery voltage	Recharge the battery to 12.8 VDC
Loose battery connections	Check all connections and tighten
Loose solenoid connections	Check all connections and tighten

Engine Turns Over, Fails to Start

Possible Cause	Solution
Out of fuel	Refuel, cycle key to ON position three times for 5 seconds each, then start
Water is present in fuel	Drain the fuel system and refuel
Old or non-recommended fuel	Replace with fresh recommended fuel
Fouled or defective spark plug(s)	Inspect plugs and replace if necessary
No spark to spark plug	Inspect plugs, verify stop switch is on
Water or fuel in crankcase	Immediately see your POLARIS dealer
Low battery voltage	Recharge the battery to 12.8 VDC
Mechanical failure	See your dealer

Engine Backfires

Possible Cause	Solution
Weak spark from spark plug	Inspect, clean and/or replace spark plug(s)
Incorrect spark plug gap or heat range	Set gap to specs or replace plugs
Old or non-recommended fuel	Replace with fresh recommended fuel
Incorrectly installed spark plug wires	See your dealer
Incorrect ignition timing	See your dealer
Mechanical failure	See your dealer
Loose ignition connections	Check all connections and tighten
Water present in fuel	Replace with fresh recommended fuel
Leaking exhaust components	See your dealer

TROUBLESHOOTING

Engine Pings or Knocks

Possible Cause	Solution
Poor quality or low octane fuel	Replace with recommended fuel
Incorrect ignition timing	See your dealer
Incorrect spark plug gap or heat range	Set gap to specs or replace plugs

Engine Runs Irregularly, Stalls or Misfires

Possible Cause	Solution
Fouled or defective spark plug(s)	Inspect, clean and/or replace spark plugs
Worn or defective spark plug wires	See your dealer
Incorrect spark plug gap or heat range	Set gap to specs or replace plugs
Loose ignition connections	Check all connections and tighten
Water present in fuel	Replace with new fuel
Low battery voltage	Recharge battery to 12.8 VDC
Kinked or plugged fuel tank vent line	Inspect and replace
Incorrect fuel	Replace with recommended fuel
Clogged air filter	Inspect and clean or replace
Reverse speed limiter malfunction	See your dealer
Electronic throttle control malfunction	See your dealer
Other mechanical failure	See your dealer

Possible Lean Fuel Cause	Solution
Low or contaminated fuel	Add or change fuel, clean the fuel system
Kinked or plugged fuel tank vent line	Inspect and replace
Low octane fuel	Replace with recommended fuel
Incorrect fuel	Replace with recommended fuel

Possible Rich Fuel Cause	Solution
Fuel is very high octane	Replace with lower octane fuel
Stopping/starting without adequate warm-up	Allow engine to warm up before operating and/or stopping
Incorrect fuel	Replace with recommended fuel
Clogged air filter	Inspect and clean or replace

TROUBLESHOOTING

Engine Stops or Loses Power

Possible Cause	Solution
Out of fuel	Refuel, cycle key to ON position three times for 5 seconds each, then start
Kinked or plugged fuel vent line	Inspect and replace
Water is present in fuel	Replace with new fuel
Fouled or defective spark plug(s)	Inspect, clean and/or replace spark plugs
Worn or defective spark plug wires	See your dealer
Incorrect spark plug gap or heat range	Set gap to specs or replace plug
Loose ignition connections	Check all connections and tighten
Low battery voltage	Recharge the battery to 12.8 VDC
Incorrect fuel	Replace with fresh recommended fuel
Clogged air filter	Inspect and clean or replace
Reverse speed limiter malfunction	See your dealer
Electronic throttle control malfunction	See your dealer
Other mechanical failure	See your dealer
Overheated engine	Clean radiator screen and core, clean engine exterior, see your dealer

Engine Overheating

Possible Cause	Solution
Debris lodged in screen	Clean the screen.
Plugged Radiator	Use a garden hose to flush any debris from the radiator fins. NOTICE: High pressure washers can deform the radiator fins and reduce cooling efficiency.

POLARIS PRODUCTS

Part Number	Description
Engine Lubricant	
2870791	Fogging Oil (12 oz./355 ml Aerosol)
2876244	PS-4 PLUS Performance Synthetic 2W-50 4-Cycle Oil (qt./.95 l)
2876245	PS-4 PLUS Performance Synthetic 2W-50 4-Cycle Oil (gal./3.8 l)
Gearcase / Transmission Lubricants	
2878068	AGL PLUS Transmission Fluid (qt./.95 l)
2878069	AGL PLUS Transmission Fluid (gal./3.8 l)
2877922	Demand Drive Plus Fluid (qt./.95 l)
2877923	Demand Drive Plus Fluid (gal./3.8 l)
2871653	Premium ATV Angle Drive Fluid (8 oz./237 ml)
2872276	Premium ATV Angle Drive Fluid (2.5 gal./9.5 l)
2870465	Pump for Gallon (3.8 l) Jug
Coolant	
2871323	60/40 Coolant (gal./3.8 l)
2871534	60/40 Coolant (qt./.95 l)
Grease / Specialized Lubricants	
2871312	Grease Gun Kit, Premium All Season
2871322	Premium All Season Grease (3 oz./89 ml cartridge)
2871423	Premium All Season Grease (14 oz./414 ml cartridge)
2871460	Starter Drive Grease
2871515	Premium U-Joint Lube (3 oz./89 ml cartridge)
2871551	Premium U-Joint Lube (14 oz./414 ml cartridge)
2871329	Dielectric Grease (Nyogel™)
Additives / Miscellaneous	
2871326	Carbon Clean Plus
2870652	Fuel Stabilizer
2872189	DOT 4 Brake Fluid
2871956	Loctite™ 565 Thread Sealant
2859044	POLARIS Battery Tender™ Charger

SPECIFICATIONS

SPORTSMAN 550 Touring

Maximum Weight Capacity	735 lbs. (333 kg) (includes operator, passenger, cargo, accessories)
Dry Weight	765 lbs. (347 kg)
Front Rack/Storage Box Capacity	120 lbs. (54 kg)
Rear Rack Capacity	240 lbs. (109 kg)
Hitch Tongue Weight	150 lbs. (68 kg) (Rear rack capacity and tongue weight not to exceed 240 lbs./109 kg)
Hitch Towing Rating	1500 lbs. (680 kg) on level ground
Unbraked Trailer Towing Capacity*	1995 lbs. (905 kg)
Overall Length	86.5 in. (219.7 cm)
Overall Width	47.6 in. (121 cm)
Overall Height	58.25 in. (148 cm)
Wheelbase	57 in. (145 cm)
Ground Clearance	11.6 in. (29.5 cm)
Minimum Turning Radius	96 in. (244 cm) unloaded
Fuel Capacity	5.25 gal. (20 l)
Engine Oil Capacity	2 qts. (1.9 l)
Coolant Capacity	2 qts. (1.9 l)
Demand Drive Fluid Capacity	9.3 oz. (275 ml)
Transmission Fluid Capacity	32 oz. (946 ml)
Rear Gearcase Fluid Capacity	7.1 oz. (210 ml)
Fuel System	Visteon Electronic Fuel Injection
Fuel Delivery	Electronic Fuel Pump (in tank)
Engine	ES550PLE011
Displacement	549 cc
Bore x Stroke	96.6 x 75 mm
Alternator Output	490w @ 1350 RPM/Peak 630w
Compression Ratio	9.6:1
Starting System	Electric
Ignition System	Visteon EFI (ECU Controlled)
Ignition Timing	13° +/- 3° BTDC @ 1650 RPM
Idle RPM**	1750 +/- 50
Throttle Body/Size	Mikuni/42 mm
Spark Plug / Gap	NGK BKR6E / .035 in. (0.9 mm)

* Based on EU Directive 76/432/EC

**A higher initial idle speed of 1800 RPM will occur for the first few minutes of operation.

SPECIFICATIONS

SPORTSMAN 550 Touring

Lubrication System	Pressurized Wet Sump
Transmission Type	Automatic PVT (POLARIS Variable Transmission) In-Line H-L-N-R-P
Front Suspension	Dual a-arm, 9" (22.9 cm) travel
Rear Suspension	Dual a-arm with Rolled IRS, 10" (25.4 cm) travel
Gear Reduction, Low	5.034:1
Gear Reduction, Reverse	4.508:1
Gear Reduction, High	2.693:1
Drive Ratio, Front	3.818:1
Drive Ratio, Rear	3.7:1
Tire Type/Pressure, Front	Maxxis AT 26 x 8 - 14 / 7 psi (48.3 kPa)
Tire Type/Pressure, Rear	Maxxis AT 26 x 10 - 14 / 5 psi (34.5 kPa)
Brakes, Front/Rear	Single-Control Hydraulic Disc, All-Wheel
Brake, Auxiliary	Foot-Activated Hydraulic Disc, Rear Wheel
Brake, Parking	Hydraulic lock, all wheel
Headlight	1 Single Beam on Headlight Pod (50 watt) 2 Single Beam on Bumper (50 watt)
Taillight	12v/7 watts
Brake Light	12v/27 watts
Instrumentation	Digital/Analog

Clutching

Altitude		Shift Weight	Drive Clutch Spring	Driven Clutch Spring	Helix*
Meters (Feet)	0-1800 (0-6000)	23-58 PN 1322911	Red/Black PN 7043500	Red/White PN 3235088	105-165 BA3 PN 3235092
	1800-3700 (6000-12000)	23-54 PN 1322914	Red/Black PN 7043500	Red/White PN 3235088	105-165 BA3 PN 3235092

*EBS models require no helix/spring adjustment

SPECIFICATIONS

SPORTSMAN 850 Touring

Maximum Weight Capacity	735 lbs. (333 kg) (includes operator, passenger, cargo, accessories)
Dry Weight	798 lbs. (362 kg)
Front Rack/Storage Box Capacity	120 lbs. (54 kg)
Rear Rack Capacity	240 lbs. (109 kg)
Hitch Tongue Weight	150 lbs. (55 kg) (Rear rack capacity and tongue weight not to exceed 240 lbs./55 kg)
Hitch Towing Rating	1500 lbs. (680 kg) on level ground
Unbraked Trailer Towing Capacity*	1995 lbs. (905 kg)
Overall Length	86.5 in. (219.7 cm)
Overall Width	47.6 in. (121 cm)
Overall Height	58.25 in. (148 cm)
Wheelbase	57 in. (145 cm)
Ground Clearance	11.6 in. (29.5 cm)
Minimum Turning Radius	96 in. (244 cm) unloaded
Fuel Capacity	5.25 gal. (20 l)
Engine Oil Capacity	2 qts. (1.9 l)
Coolant Capacity	2 qts. (1.9 l)
Demand Drive Fluid Capacity	9.3 oz. (275 ml)
Transmission Fluid Capacity	32 oz. (946 ml)
Rear Gearcase Fluid Capacity	7.1 oz. (210 ml)
Fuel System	Bosch Multi-Port Sequential Electronic Fuel Injection
Fuel Delivery	Electronic Fuel Pump (in tank)
Engine	EH085OLE013
Displacement	850 cc
Bore x Stroke	87 x 71.5 mm
Alternator Output	475w @ 1200 RPM/Peak 630w
Compression Ratio	11.0:1
Starting System	Electric
Ignition System	Bosch EFI (ECU Controlled)
Ignition Timing	6° +/- 5° BTDC @ 1200 RPM
Idle RPM	1200 +/- 50
Throttle Body/Size	Mikuni Dual Bore/40 mm
Spark Plug / Gap	REA8MCX / .035 in. (0.9 mm)

* Based on EU Directive 76/432/EC

SPECIFICATIONS

SPORTSMAN 850 Touring

Lubrication System	Pressurized Wet Sump
Transmission Type	Automatic PVT (POLARIS Variable Transmission) In-Line H-L-N-R-P
Front Suspension	Dual a-arm, 9" (22.9 cm) travel
Rear Suspension	Dual a-arm with Rolled IRS, 10" (25.4 cm) travel
Gear Reduction, Low	5.034:1
Gear Reduction, Reverse	4.508:1
Gear Reduction, High	2.367:1
Drive Ratio, Front	3.818:1
Drive Ratio, Rear	3.7:1
Tire Type/Pressure, Front	Maxxis AT 26 x 8 - 14 / 7 psi (48 kPa)
Tire Type/Pressure, Rear	Maxxis AT 26 x 10 - 14 / 5 psi (34.5 kPa)
Brakes, Front/Rear	Single-Control Hydraulic Disc, All-Wheel
Brake, Auxiliary	Foot-Activated Hydraulic Disc, Rear Wheel
Brake, Parking	Hydraulic lock, all wheel
Headlight	1 Single Beam on Headlight Pod (50 watt) 2 Single Beam on Bumper (50 watt)
Taillight	12v/7 watts
Brake Light	12v/27 watts
Instrumentation	Digital/Analog

Clutching

Altitude		Shift Weight	Drive Clutch Spring	Driven Clutch Spring	Helix*
Meters (Feet)	0-1800 (0-6000)	24-68 PN5632418	Red/Green PN 7043382	Red/White PN 3235088	105-165 BA3 PN 3235092
	1800-3700 (6000-12000)	24-63 PN 5632215	Red/White PN 7043349	Red/White PN 3235088	105-165 BA3 PN 3235092

*EBS models require no helix/spring adjustment

DECLARATION OF CONFORMITY

Polaris Industries Inc.,
2100 Hwy 55, Medina, MN 55340 U.S.A.
Telephone 763-542-0500
April 22, 2010



We, Polaris Industries Inc., declare that the vehicles listed below conform to the essential health and safety requirements applicable to off-road all-terrain vehicles.

APPLICABLE EUROPEAN DIRECTIVES	TEST / EVALUATION METHODS	
2006/42/EC as amended (Machinery Directive)	EN 1050 hazard analysis prEN 15997 driver-perceived noise level prEN 15997 vibration	
2004/108/EC as amended (EMC Directive)	CISPR 12:2009 CAN/CSA-C108.4-M92	EN 55012:2007 EN 61000-6-2:2005

PRODUCT IDENTIFICATION

VEHICLE SERIES	TRADE NAME	MODEL YEARS
__KA05__ / __KA09__	OUTLAW 50 / 90	2008, 2009, 2010, 2011
__FA09__	SPORTSMAN 90	2008, 2009, 2010, 2011
__VA17__	RZR 170	2009, 2010, 2011
__PB20__	PHOENIX 200	2008, 2009, 2010, 2011
__BA32__ , __NA32__	TRAIL BLAZER 330	2008, 2009, 2010, 2011
__CA32__ , __EA32__	TRAIL BOSS 330	2008, 2009, 2010, 2011
__BA50__ , __BG50__	SCRAMBLER 500	2008, 2009, 2010, 2011
__GJ45__	OUTLAW 450	2008, 2009, 2010, 2011
__GJ52__ , __GP52__	OUTLAW 525 / 525 S	2008, 2009, 2010, 2011
__LH46__	SPORTSMAN 400	2008, 2009, 2010, 2011
__MH50__	SPORTSMAN 500 HO	2008, 2009, 2010, 2011
__DH50__	SPORTSMAN 500 HO TOURING	2010, 2011
__ZN55__ , __ZX55__	SPORTSMAN 550 EFI	2009, 2010, 2011
__TN55__ , __TX55__	SPORTSMAN 550 X2	2010, 2011
__DN55__ , __DX55__	SPORTSMAN 550 TOURING	2010, 2011
__MN76__	SPORTSMAN 800	2008, 2009, 2010, 2011
__CL76__ , __CF76__	SPORTSMAN 800 6X6	2009, 2010, 2011
__ZN85__ , __ZX85__	SPORTSMAN 850 EFI	2009, 2010, 2011
__TN85__ , __TX85__	SPORTSMAN 850 X2	2010, 2011
__DN85__ , __DX85__	SPORTSMAN 850 TOURING	2010, 2011
__RH45__	RANGER 400	2010, 2011
__WH45__	RANGER 400 CREW	2011
__RH50__	RANGER 500 4X4	2010, 2011
__TH76__	RANGER 800 EFI 4X4	2010, 2011
__WH76__	RANGER 800 EFI CREW	2010, 2011
__HR76__	RANGER 800 6X6	2010, 2011
__HY76__ , __TY76__	RANGER HD 800 4X4	2010, 2011
__TH90__	RANGER DIESEL	2011
__WH90__	RANGER DIESEL CREW	2011
__VH76__ , __VY76__	RANGER RZR / RZR S	2008, 2009, 2010, 2011
__XH76__	RANGER RZR 4	2011

European Community Person Authorized to Compile the Technical File: Ross Clifford, General Manager Polaris Britain Ltd Forge Mills Park, Station Road Coleshill, Warwickshire B46 1HT	Authorized Manufacturer Signatory Empowered to Draw up the EC Declaration of Conformity: Lawrence E. Keller, Product Compliance Manager 7290 East Viking Blvd. Wyoming, MN 55092
--	---

WARRANTY

LIMITED WARRANTY

POLARIS Sales Inc., 2100 Highway 55, Medina, MN 55340, gives a SIX MONTH LIMITED WARRANTY on all components of the POLARIS All Terrain Vehicle (ATV) against defects in material or workmanship. POLARIS also gives a one year limited warranty on the final drive chain (if equipped) for failure due to defects. This warranty covers the parts and labor charges for repair or replacement of defective parts which are covered by this warranty. This warranty begins on the date of purchase. This warranty is transferable to another consumer during the warranty period through a POLARIS dealer.

REGISTRATION

At the time of sale, the Warranty Registration Form must be completed by your dealer and submitted to POLARIS within ten days. Upon receipt of this registration, POLARIS will record the registration for warranty. No verification of registration will be sent to the purchaser as the copy of the Warranty Registration Form will be the warranty entitlement. If you have not signed the original registration and received the customer copy, please contact your dealer immediately. **NO WARRANTY COVERAGE WILL BE ALLOWED UNLESS YOUR ATV IS REGISTERED WITH POLARIS.**

Initial dealer preparation and set-up of your ATV is very important in ensuring trouble-free operation. Purchasing a machine in the crate or without proper dealer set-up will void your warranty coverage.

WARRANTY COVERAGE AND EXCLUSIONS: LIMITATIONS OF WARRANTIES AND REMEDIES

The POLARIS limited warranty excludes any failures that are not caused by a defect in material or workmanship. This warranty does not cover accidental damage, normal wear and tear, abuse or improper handling. This warranty also does not cover any ATV that has been altered structurally, modified, neglected, improperly maintained, used for racing, or used for purposes other than for which it was manufactured, or for any damages which occur during trailer transit or as a result of unauthorized service or the use of unauthorized parts. In addition, this warranty does not cover physical damage to paint or finish, stress cracks, tearing or puncturing of upholstery material, corrosion, or defects in parts, components or the ATV due to fire, explosions or any other cause beyond POLARIS' control.

Warranty does not apply to parts exposed to friction surfaces, stresses, environmental conditions and/or contamination for which they were not designed or not intended, including but not limited to the following items:

- Wheels and tires
- Suspension components
- Brake components
- Seat components
- Clutches and components
- Steering components
- Batteries
- Light bulbs/Sealed beam lamps
- Finished and unfinished surfaces
- Carburetor/Throttle body components
- Engine components
- Drive belts
- Hydraulic components
- Circuit breakers/Fuses
- Electronic components

WARRANTY

LIMITATIONS OF WARRANTIES AND REMEDIES

Warranty applies to the product only and does not allow for coverage of personal loss. Some items are considered “consumable,” meaning they are considered part of normal maintenance or part of completing an effective repair. The following items are excluded from warranty coverage in the event of a warranty claim:

- Spark Plugs
- Filters
- Fuel
- Sealants
- Hotel fees
- Towing charges
- Mileage
- Rentals/Loss of product use
- Lubricants such as oil, grease, etc.
- Batteries (unless defective)
- Cosmetic damage/repair
- Coolants
- Meals
- Shipping/ handling fees
- Product pick-up/delivery
- Loss of vacation/personal time

This warranty also excludes failures resulting from improper lubrication; improper engine timing; improper fuel; surface imperfections caused by external stress, heat, cold or contamination; operator error or abuse; improper component alignment, tension, adjustment or altitude compensation; failure due to snow, water, dirt or other foreign substance ingestion/contamination; improper maintenance; modified components; use of aftermarket components resulting in failure; unauthorized repairs; repairs made after the warranty period expires or by an unauthorized repair center; use of the product in competition or for commercial purposes. Warranty will not apply to any product which has been damaged by abuse, accident, fire or any other casualty not determined a defect of materials or workmanship.

This warranty does not cover the use of unauthorized lubricants, chemicals, or fuels that are not compatible with the ATV. The exclusive remedy for breach of this warranty shall be, at POLARIS' exclusive option, repair or replacement of any defective materials, or components or products. **THE REMEDIES SET FORTH IN THIS WARRANTY ARE THE ONLY REMEDIES AVAILABLE TO ANY PERSON FOR BREACH OF THIS WARRANTY. POLARIS SHALL HAVE NO LIABILITY TO ANY PERSON FOR INCIDENTAL, CONSEQUENTIAL OR SPECIAL DAMAGES OF ANY DESCRIPTION, WHETHER ARISING OUT OF EXPRESS OR IMPLIED WARRANTY OR ANY OTHER CONTRACT, NEGLIGENCE, OR OTHER TORT OR OTHERWISE. THIS EXCLUSION OF CONSEQUENTIAL, INCIDENTAL, AND SPECIAL DAMAGES IS INDEPENDENT FROM AND SHALL SURVIVE ANY FINDING THAT THE EXCLUSIVE REMEDY FAILED OF ITS ESSENTIAL PURPOSE.** Some states do not permit the exclusion or limitation of incidental or consequential damages or implied warranties, so the above limitations or exclusions may not apply to you if inconsistent with controlling state law.

WARRANTY

ALL IMPLIED WARRANTIES (INCLUDING BUT NOT LIMITED TO THE IMPLIED WARRANTIES OF MERCHANTABILITY AND FITNESS FOR A PARTICULAR PURPOSE) ARE LIMITED IN DURATION TO THE ABOVE SIX MONTH WARRANTY PERIOD. POLARIS FURTHER DISCLAIMS ALL EXPRESS WARRANTIES NOT STATED IN THIS WARRANTY. Some states do not allow limitations on how long an implied warranty lasts, so the above limitation may not apply to you if inconsistent with controlling state law.

HOW TO OBTAIN WARRANTY SERVICE

If your ATV requires warranty service, you must take it to a POLARIS dealer authorized to repair POLARIS ATVs. When requesting warranty service you must present your copy of the Warranty Registration form to the dealer. (THE COST OF TRANSPORTATION TO AND FROM THE DEALER IS YOUR RESPONSIBILITY). POLARIS suggests that you use your original selling dealer; however, you may use any POLARIS Servicing Dealer to perform warranty service.

Please work with your dealer to resolve any warranty issues. Should your dealer require any additional assistance they will contact the appropriate person at POLARIS.

This warranty gives you specific legal rights, and you may also have other rights which vary from state to state.

If any of the above terms are void because of state or federal law, all other warranty terms will remain in effect.

Engine Oil

1. Mixing oil brands or using non-recommended oil may cause engine damage. We recommend the use of POLARIS engine oil for your ATV.
2. Damage resulting from the use of non-recommended lubricants may not be covered by warranty.

SPARK ARRESTOR

POLARIS warrants that the spark arrestor in this vehicle will meet the efficiency requirements of USFS standard 5100-1c for at least 1000 hours when subjected to normal use and when maintenance and installation are in accordance with POLARIS recommendations.

WARRANTY

Exported Vehicles

EXCEPT WHERE SPECIFICALLY REQUIRED BY LAW, THERE IS NO WARRANTY OR SERVICE BULLETIN COVERAGE ON THIS VEHICLE IF IT IS SOLD OUTSIDE THE COUNTRY OF THE SELLING DEALER'S AUTHORIZED LOCATION.

This policy does not apply to vehicles that have received authorization for export from POLARIS Industries. Dealers may not give authorization for export. You should consult an authorized dealer to determine this vehicle's warranty or service bulletin coverage if you have any questions.

This policy does not apply to vehicles registered to government officials or military personnel on assignment outside the country of the selling dealer's authorized location.

This policy does not apply to Safety Bulletins.

How to Get Service

In the Country where your vehicle was purchased:

Warranty or Service Bulletin repairs must be done by an authorized POLARIS dealer. If you move or are traveling within the country where your vehicle was purchased, Warranty or Service Bulletin repairs may be requested from any authorized POLARIS dealer who sells the same line as your vehicle.

Outside the Country where your vehicle was purchased:

If you are traveling temporarily outside the country where your vehicle was purchased, you should take your vehicle to an authorized POLARIS dealer. You must show the dealer photo identification from the country of the selling dealer's authorized location as proof of residence. Upon residence verification, the servicing dealer will be authorized to perform the warranty repair.

If You Move:

If you move to another country, be sure to contact POLARIS Customer Assistance and the customs department of the destination country before you move. Vehicles importation rules vary considerably from country to country. You may be required to present documentation of your move to POLARIS Industries in order to continue your warranty coverage. You may also be required to obtain documentation from POLARIS Industries in order to register your vehicle in your new country. You should warranty register your vehicle at a local POLARIS dealer in your new country immediately after you move to continue your warranty coverage and to ensure that you receive safety information and notices regarding your vehicle.

Exported Vehicles

How to Get Service

If Purchased From A Private Party:

If you purchase a POLARIS product from a private citizen, to be kept and used outside of the country in which the vehicle was originally purchased, all warranty coverage will be denied. You must nonetheless warranty register your vehicle under your name and address with a local POLARIS dealer in your country to ensure that you receive safety information and notices regarding your vehicle.

Notice

If your vehicle is registered outside of the country where it was purchased, and you have not followed the procedure set out above, your vehicle will no longer be eligible for warranty or service bulletin coverage of any kind, other than *safety* bulletins. (Vehicles registered to Government officials or military personnel on assignment outside of the country where the vehicle was purchased will continue to be covered by the basic warranty.)

For questions call POLARIS Customer Assistance:

United States: 1-888-704-5290

Canada: 1-204-925-7100

WARRANTY

U.S.A. EPA Emissions Limited Warranty

This emissions limited warranty is in addition to the POLARIS standard limited warranty for your vehicle. POLARIS Industries Inc. warrants that at the time it is first purchased, this emissions-certified vehicle is designed, built and equipped so it conforms with applicable U.S. Environmental Protection Agency emission regulations. POLARIS warrants that the vehicle is free from defects in materials and workmanship that would cause it to fail to meet these regulations.

The warranty period for this emissions-certified vehicle starts on the date the vehicle is first purchased and continues for a period of 500 hours of engine operation, 5000 kilometers (3100 miles) of vehicle travel, or 30 calendar months from the date of purchase, whichever comes first.

This emissions limited warranty covers components whose failure increases the vehicle's regulated emissions, and it covers components of systems whose only purpose is to control emissions. Repairing or replacing other components not covered by this warranty is the responsibility of the vehicle owner. This emissions limited warranty does not cover components whose failure does not increase the vehicle's regulated emissions.

For exhaust emissions, emission-related components include any engine parts related to the following systems:

- Air-induction system
- Fuel system
- Ignition system
- Exhaust gas recirculation systems

The following parts are also considered emission-related components for exhaust emissions:

- Aftertreatment devices
- Crankcase ventilation valves
- Sensors
- Electronic control units

The following parts are considered emission-related components for evaporative emissions:

- Fuel Tank
- Fuel Cap
- Fuel Line
- Fuel Line Fittings
- Clamps*
- Pressure Relief Valves*
- Control Valves*
- Control Solenoids*
- Electronic Controls*
- Vacuum Control Diaphragms*
- Control Cables*
- Control Linkages*
- Purge Valves
- Vapor Hoses
- Liquid/Vapor Separator
- Carbon Canister
- Canister Mounting Brackets
- Carburetor Purge Port Connector

*As related to the evaporative emission control system.

WARRANTY

U.S.A. EPA Emissions Limited Warranty

The exclusive remedy for breach of this limited warranty shall be, at the exclusive option of POLARIS, repair or replacement of any defective materials, components or products. THE REMEDIES SET FORTH IN THIS LIMITED WARRANTY ARE THE ONLY REMEDIES AVAILABLE TO ANY PERSON FOR BREACH OF THIS WARRANTY. POLARIS SHALL HAVE NO LIABILITY TO ANY PERSON FOR INCIDENTAL, CONSEQUENTIAL OR SPECIAL DAMAGES OF ANY DESCRIPTION, WHETHER ARISING OUT OF EXPRESS OR IMPLIED WARRANTY OR ANY OTHER CONTRACT, NEGLIGENCE OR OTHER TORT OR OTHERWISE. THIS EXCLUSION OF CONSEQUENTIAL, INCIDENTAL, AND SPECIAL DAMAGES IS INDEPENDENT FROM AND SHALL SURVIVE ANY FINDING THAT THE EXCLUSIVE REMEDY FAILED OF ITS ESSENTIAL PURPOSE.

ALL IMPLIED WARRANTIES (INCLUDING BUT NOT LIMITED TO ANY IMPLIED WARRANTIES OF MERCHANTABILITY AND FITNESS FOR A PARTICULAR PURPOSE) ARE LIMITED IN DURATION TO THE WARRANTY PERIOD DESCRIBED HEREIN. POLARIS DISCLAIMS ALL EXPRESS WARRANTIES NOT STATED IN THIS WARRANTY. Some states do not allow limitations on how long an implied warranty lasts, so the above limitation may not apply if it is inconsistent with the controlling state law.

This limited warranty excludes failures not caused by a defect in material or workmanship. This limited warranty does not cover damage due to accidents, abuse or improper handling, maintenance or use. This limited warranty also does not cover any engine that has been structurally altered, or when the vehicle has been used in racing competition. This limited warranty also does not cover physical damage, corrosion or defects caused by fire, explosions or other similar causes beyond the control of POLARIS.

Owners are responsible for performing the scheduled maintenance identified in the owner's manual. POLARIS may deny warranty claims for failures that have been caused by the owner's or operator's improper maintenance or use, by accidents for which POLARIS has no responsibility, or by acts of God.

Any qualified repair shop or person may maintain, replace, or repair the emission control devices or systems on your vehicle. POLARIS recommends that you contact an authorized POLARIS dealer to perform any service that may be necessary for your vehicle. POLARIS also recommends that you use only Pure POLARIS parts. It is a potential violation of the Clean Air Act if a part supplied by an aftermarket parts manufacturer reduces the effectiveness of the vehicle's emission controls. Tampering with emission controls is prohibited by federal law.

If you have any questions regarding your warranty rights and responsibilities, please contact the POLARIS Warranty Department at 1-888-704-5290.

INDEX

0-9

4X4 Switch 26, 37

A

Accessories 126
Active Descent Control Fluid . . . 87-88
Active Descent Control System . . . 39
ADC System 39
Air Filter 101
All Wheel Drive System 37-38
Auxiliary Foot Brake 93

B

Battery 115-118
 Charging 117-118
 Installation 116
 Removal 115
 Storage 116
Belt Life 33
Beverage Holders 34
Boots 9
Box, Front 36
Brake Fluid, Auxiliary Foot Brake . . 32
Brake Fluid, Main Brake System . . . 30
Brake Lever 29
Brake, Foot 32, 93
Brake, Hand Lever 93
Brake, Parking 31
Brakelight Lamp Replacement . . . 107
Brakes 93
Break-In Period 52-53

C

Camber Adjustment 119
Cargo 73-74
Cargo Loading 72
Caster Adjustment 119
Check Engine Indicator 47
Cleaning and Storage 122-126
Clothing 9
Clutching (550) 133
Clutching (850) 135

C

Cold Weather Operation 57
Consumer Product Safety 7
Coolant Bottle 91
Coolant, Radiator 92
Cooling System 90-92
Crankcase Emission Control System . 75

D

Demand Drive Fluid 86
Diagnostic Codes, 550 48-49
Diagnostic Codes, 850 50-51
Disengaging Active Descent Control . 39
Display Units, Standard/Metric . . . 44
Drink Holders 34
Drive Belt Wear/Burn 127
Drivetrain Break-In 53
Driving Downhill 65
Driving in Reverse 70
Driving on a Sidehill 64
Driving on Slippery Surfaces 62
Driving Over Obstacles 69
Driving Procedures 58
Driving Through Water 68
Driving Uphill 63
Driving with a Passenger 60-61

E

Electromagnetic Interference 75
Electronic Power Steering 34
Emissions Limited Warranty . . . 142-143
Engaging 4X4 38
Engaging Active Descent Control . . . 39
Engine Break-In 53
Engine Fogging 125
Engine Oil 81-83
Engine Stop Switch 27
EPS 34
Equipment Modifications 9
Error Codes, Engine 47
Etiquette, Trail Riding 56
Exhaust Emission Control System . . 75
Eye Protection 9

INDEX

F

Fluid

Active Descent Control	87
ADC	87-88
Brake	30
Demand Drive	86
Engine Oil	81-83
Front Gearcase	86
Rear Gearcase Oil	89
Transmission	84-85

Fluid Change

ADC	88
Demand Drive	86
Engine Oil	82-83
Rear Gearcase	89
Transmission	85

Fluid Level

ADC	87
Brake	30
Brake (Auxiliary)	32
Brake Fluid	30
Coolant (Bottle)	91
Coolant (Radiator)	92
Demand Drive	86
Engine Oil	81
Rear Gearcase	89
Transmission	84
Foot Brake, Auxiliary	32
Footwell Removal	97
Front Box	36
Front Gearcase Fluid	86
Fuel Recommendations	35
Fuel Safety	11
Fuel Tank Cap	35
Fuse Replacement	102

G

Gasoline Handling	11
Gauge, Code Definitions	48-51
Gauge, Digital/Analog	40-47
Gear Selector	33
Gearcase Oil, Front	86
Gearcase Oil, Rear	89
Gloves	9

H

Hand Brake	93
Handlebar Adjustment	119
Hauling Cargo	72-74
Headlight Housing Replacement	106
Headlight Lamp Replacement	103
Headlight Switch	27
Helmet	8
High Beam Adjustment	104
High Range Use	114
Hub Tightening	99

I

Idle RPM Adjustment	120
Immersion Maintenance	110
Indicator Lamps	41
Instrument Cluster	40-51

K

Key Switch	27
K-Turn	66-67

L

Lights	103-107
Headlight Housing	106
Headlight Lamp	103
High Beam Adjustment	104
Low Beam Adjustment	105
Lower Headlamp Replacement	107
Taillight/Brakelight/Worklight	107
Low Beam Adjustment	105
Low Range Use	114
Lower Headlamp Replacement	107
Lubrication Guide	80

M

Maintenance Chart	76-79
Master Cylinder	30
Metric Display	44
Mode Switch	26
Modifications	9

N

Noise Emission Control System	75
-------------------------------	----

INDEX

O

Oil	
Engine	81-83
Rear Gearcase	89
Transmission	84-85
Oil Change	
Engine	82-83
Rear Gearcase	89
Transmission	85
Oil Level	
Engine	81
Rear Gearcase	89
Transmission	84
Oil Recommendations	81
Operation on Public Lands	75
Override Switch	26

P

Parking Brake	31
Parking on an Incline	71
Passenger Seat	34
Periodic Maintenance Chart	76-79
Polaris Product List	131
Polishing the Vehicle	123
Power Steering	34
Power Steering Unit (Cleaning)	90
Pre-Ride Checklist	54
PVT Break-In	53
PVT Drying	114
PVT System	112-114

R

Rear Gearcase Oil	89
Reverse Operation	70
Reverse Override Switch	26
Rider Information Center	42-47
Riding Area	56
Riding Gear	8-9

S

Safe Operation Practices	55
Safety Labels	22-25
Safety Training	7
Safety Warnings	10-21
Age Restrictions	10
Carrying a Passenger	12
Carrying Multiple Passengers	12
Crossing Hillsides	15
Deep Water	19
Descending Hills Improperly	15
Excessive Speeds	13
Exhaust Exposure	11
Failure to Inspect	11
Frozen Bodies of Water	20
Handling Gasoline	11
Hot Exhaust Systems	21
Improper Cargo Loading	19
Improper Hill Climbing	15
Improper Tire Maintenance	18
Jumps and Stunts	14
Operating a Damaged ATV	21
Operating on Pavement	13
Operating on Public Roads	13
Operating on Steep Hills	16
Operating Over Obstacles	18
Operating Without Instruction	10
Physical Control of the ATV	14
Physical Skills	21
Poor Visibility	20
Protective Apparel	12
Reverse Operation	17
Skidding or Sliding	18
Slippery Terrain	17
Stalling While Climbing a Hill	16
Turning Improperly	14
Unauthorized Use	21
Unfamiliar Terrain	17
Using Alcohol or Drugs	12
Seats	95-96

INDEX

S

Severe Use	76
Side Panel Removal	97
Sidehilling	64
Signal Words.....	4
Spark Arrestor.....	111
Spark Plug Inspection	108-109
Spark Plug Recommendations	108
Spark Plug Torque Specification ..	108
Spark Plugs	108-109
Specifications	132-135
Speedometer	40
Spring Adjustment, Rear Shock ...	119
Starting the Engine	57
Steering Assembly	90
Storage	122-126
Storage Box, Front	36
Storage Tips	124-125
Suspension, Passenger Seat	96
Switches	26-27
4X4 Switch	26, 37
Engine Stop Switch.....	27
Headlight Switch.....	27
Main Key Switch	27
Mode/Reverse Override Switch	26

T

Taillight Lamp Replacement	107
Throttle Body Adjustment	120
Throttle Cable Freeplay Adjustment ..	120, 121
Throttle Lever	28
Tire Tread Depth.....	98
Tires	98-100
Wheel Installation.....	100
Wheel Nut Torque	100
Wheel Removal	99
Toe Alignment	94
Towing Capacities	74
Towing Loads.....	74
Trail Etiquette.....	56
Training.....	7
Transmission.....	33
Transmission Oil.....	84-85
Transporting the ATV.....	126
Tread Lightly	56
Turning Around on a Hill	66-67
Turning the Vehicle	59

V

Vehicle Identification Numbers	6
Vehicle Immersion	110
VIN.....	6

W

Warning Symbols	4
Washing the Vehicle.....	122-123
Wheel Installation.....	100
Wheel Nut Torque Specifications..	100
Wheel Removal	99