

POLARIS[®]
The Way Out.

RANGER[®]

500 EFI 4X4
500 EFI CREW[®]

Owner's Manual
for Maintenance and Safety

⚠ WARNING

Read, understand, and follow all of the instructions and safety precautions in this manual and on all product labels.

Failure to follow the safety precautions could result in serious injury or death.

⚠ WARNING

The engine exhaust from this product contains chemicals known to the State of California to cause cancer, birth defects or other reproductive harm.



The text is printed on 100% recycled
with 40% post-consumer waste (PCW).

WARNING

Improper vehicle use can result in SEVERE INJURY or DEATH.

NEVER Operate:

- At speeds too fast for your skills or the conditions.
- After or while using Alcohol or Drugs.
- On hills steeper than 15 degrees $\leq 15^\circ$
- On public roads. A collision can occur with another vehicle.
- With more than ONE passenger on the 4X4, with more than THREE passengers on the CREW, or with passengers under age twelve or who cannot comfortably reach the floor and hand holds.
- On paved surfaces - pavement may seriously affect handling and control.
- With non-Polaris approved accessories - they may seriously affect stability.

ALWAYS:

- Wear your seat belt. Vehicle rollover could cause severe injury or death.
- Wear a helmet and eye protection and keep hands and feet in vehicle at all times. Use the cab nets.
- Reduce speed and use extra caution when carrying passengers.
- Avoid sharp turns or turns while applying heavy throttle.
- Operate slowly in reverse - avoid sharp turns or sudden braking.
- Make sure passenger reads and understands all safety labels.
- Watch for branches or other hazards that could enter vehicle.

**READ OWNER'S MANUAL.
FOLLOW ALL INSTRUCTIONS AND WARNINGS.**



POLARIS
The Way Out.

For your nearest Polaris dealer,
call 1-800-POLARIS
or visit www.polarisindustries.com
Polaris Sales Inc.,
2100 Hwy. 55, Medina, MN 55340
Phone 1-888-704-5290
Part No. 9923135 Rev 01
Printed in USA



WELCOME

Thank you for purchasing a POLARIS vehicle, and welcome to our world-wide family of POLARIS owners. We proudly produce an exciting line of utility and recreational products.

- Snowmobiles
- All-terrain vehicles (ATVs)
- *RANGER*® utility vehicles
- Victory Motorcycles®
- Low Emission Vehicles (LEVs)

We believe POLARIS sets a standard of excellence for all utility and recreational vehicles manufactured in the world today. Many years of experience have gone into the engineering, design, and development of your POLARIS vehicle, making it the finest machine we've ever produced.

For safe and enjoyable operation of your vehicle, be sure to follow the instructions and recommendations in this owner's manual. Your manual contains instructions for minor maintenance, but information about major repairs is outlined in the POLARIS Service Manual and should be performed only by a factory certified Master Service Dealer® (MSD) technician.

Your POLARIS dealer knows your vehicle best and is interested in your total satisfaction. Be sure to return to your dealership for all of your service needs during, and after, the warranty period.

We also take great pride in our complete line of apparel, parts and accessories, available through our online store at www.purepolaris.com. Have your accessories and clothing delivered right to your door!



POLARIS®
The Way Out.

POLARIS, THE WAY OUT, *RANGER* and *RANGER CREW* are registered trademarks of POLARIS Industries Inc.

Copyright 2010 POLARIS Sales Inc. All information contained within this publication is based on the latest product information at the time of publication. Due to constant improvements in the design and quality of production components, some minor discrepancies may result between the actual vehicle and the information presented in this publication. Depictions and/or procedures in this publication are intended for reference use only. No liability can be accepted for omissions or inaccuracies. Any reprinting or reuse of the depictions and/or procedures contained within, whether whole or in part, is expressly prohibited.

The original instructions for this vehicle are in English. Other languages are provided as translations of the original instructions.

Printed in U.S.A.

2011 *RANGER* 500 EFI 4X4 / *RANGER* 500 EFI CREW Owner's Manual

P/N 9923135

TABLE OF CONTENTS

Vehicle Identification Numbers	4
Safety	7
Features and Controls	20
Operation	39
Emission Control Systems	58
Maintenance	59
Specifications	104
POLARIS Products	106
Troubleshooting	107
Declaration of Conformity	111
Warranty	112
Maintenance Log	119
Index	122

INTRODUCTION

The *RANGER* is an off-road vehicle. Familiarize yourself with all laws and regulations concerning the operation of this vehicle in your area.

The following signal words and symbols appear throughout this manual and on your vehicle. Your safety is involved when these words and symbols are used. Become familiar with their meanings before reading the manual.



The safety alert symbol indicates a potential personal injury hazard.

WARNING

A WARNING indicates a hazardous situation which, if not avoided, may result in death or serious injury.

CAUTION

A CAUTION indicates a hazardous situation which, if not avoided, may result in minor or moderate injury.

NOTICE

A NOTICE indicates a situation that may result in property damage.



The Prohibition Safety Sign indicates an action NOT to take in order to avoid a hazard.



The Mandatory Action Sign indicates an action that NEEDS to be taken to avoid a hazard.

INTRODUCTION

WARNING

Failure to follow the warnings contained in this manual can result in severe injury or death.

A POLARIS *RANGER* is not a toy and can be hazardous to operate. This vehicle handles differently than other vehicles, such as motorcycles and cars. A collision or rollover can occur quickly, even during routine maneuvers like turning, or driving on hills or over obstacles, if you fail to take proper precautions.

- Read this owner's manual. Understand all safety warnings, precautions and operating procedures before operating the vehicle. Keep this manual with the vehicle.
- This vehicle is an **ADULT VEHICLE ONLY**. NEVER operate this vehicle if you are under age 16 and NEVER operate without a valid driver's license.
- No person under the age of 12 may ride as a passenger in this vehicle. Any passenger must be able to comfortably reach the floor and hand holds.
- Never permit a guest to operate this vehicle unless the guest has read this manual and all product labels.
- Always use the cab nets while riding in this vehicle.
- Always keep hands and feet inside the vehicle at all times.

INTRODUCTION

Vehicle Identification Numbers

Record your vehicle's identification numbers and key number in the spaces provided. Remove the spare key and store it in a safe place. An ignition key can be duplicated only by ordering a POLARIS key blank (using your key number) and mating it with one of your existing keys. The ignition switch must be replaced if all keys are lost.



VIN (4X4)



VIN (Crew)

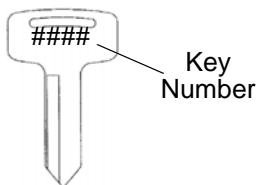

Vehicle Model Number: _____

Frame VIN: _____

Engine Serial Number: _____
(label on side of engine)

Key Number _____

Safety Labels and Locations

Warning labels have been placed on the vehicle for your protection. Read and follow the instructions of the labels on the vehicle carefully. If any of the labels depicted in this manual differ from the labels on your vehicle, always read and follow the instructions of the labels *on the vehicle*.

If any label becomes illegible or comes off, contact your POLARIS dealer to purchase a replacement. Replacement *safety* labels are provided by POLARIS at no charge. The part number is printed on the label.

Passenger/Tire Pressure Warning (4X4)

WARNING

- Passengers can be thrown off. This can cause serious injury or death.
- Never carry passengers in cargo box.

Maximum Box Load 500 lbs. (227 kg)

IMPROPER TIRE PRESSURE OR OVERLOADING can cause loss of control resulting in SEVERE INJURY OR DEATH.

TIRE PRESSURE IN PSI (KPa):

FRONT TIRE - INFLATE TO 10 psi (68.9 kPa)

REAR TIRE - INFLATE TO 12 psi (82.7 kPa)

MAXIMUM WEIGHT CAPACITY INCLUDES WEIGHT OF OPERATOR, PASSENGER, CARGO, AND ACCESSORIES. 1000 LBS. (455 kg)

Reduce speed and allow greater distance for braking when carrying cargo. Overloading or carrying tall, off-center, or unsecured loads will increase your risk of losing control. Loads should be centered and carried as low as possible in box. For stability on rough or hilly terrain, reduce speed and cargo. Be careful if load extends over the side of the box.

Read Owner's Manual for more detailed loading information.

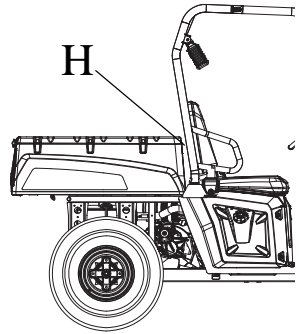

7177073

SAFETY

Safety Labels and Locations

Passenger/Tire Pressure Warning (Crew)

WARNING

- Passengers can be thrown off. This can cause serious injury or death.
- Never carry passengers in cargo box.

WARNING

Maximum Box Load 500 lbs. (227 kg)

WARNING

IMPROPER TIRE PRESSURE OR OVERLOADING can cause loss of control resulting in SEVERE INJURY OR DEATH.

TIRE PRESSURE IN PSI (KPa):

FRONT TIRE - INFLATE TO 14 psi (96.5 kPa)

REAR TIRE - INFLATE TO 16 psi (110 kPa)

MAXIMUM WEIGHT CAPACITY INCLUDES WEIGHT OF OPERATOR, PASSENGERS, CARGO, AND ACCESSORIES. 1250 LBS. (567 kg)

Reduce speed and allow greater distance for braking when carrying cargo. Overloading or carrying tall, off-center, or unsecured loads will increase your risk of losing control. Loads should be centered and carried as low as possible in box. For stability on rough or hilly terrain, reduce speed and cargo. Be careful if load extends over the side of the box.

Read Owner's Manual for more detailed loading information.

7176959

Safety Labels and Locations

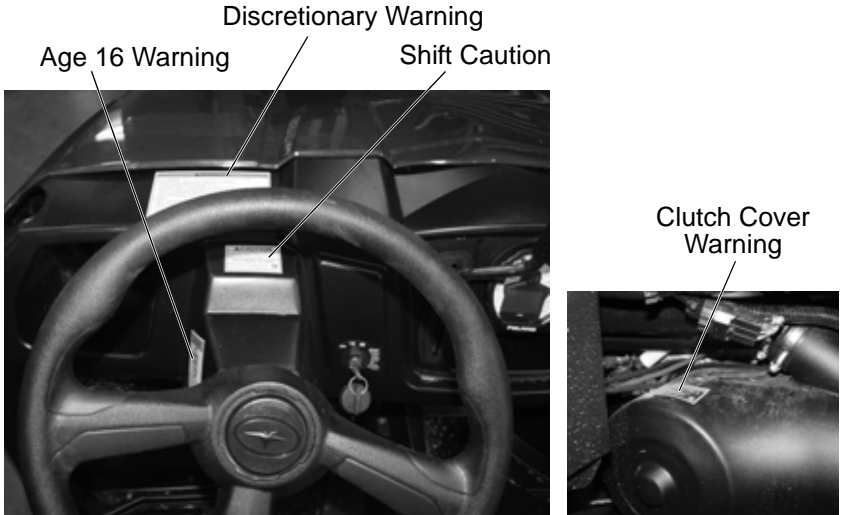

Clutch Cover Warning

WARNING

- Moving parts hazard under belt-clutch guard. To prevent serious injury, do not operate vehicle with guard removed.
- Do not modify engine or clutch. Doing so can cause part failure, possible imbalance, and excessive engine RPM which can result in serious injury or death.

7175488

Age 16 Warning

Operating this vehicle if you are under the age of 16 increases your chance of severe injury or death.

NEVER operate this vehicle if you are under age 16 and NEVER operate this vehicle without a valid driver's license.

7175566

Shift Caution

CAUTION

To avoid transmission damage, shift only when vehicle is stationary and at idle. APPLY BRAKE TO START. When this vehicle is not in operation, or unattended, place shift in the park position.

7176170

SAFETY

Safety Labels and Locations

Discretionary Warning (4X4)

WARNING

Improper vehicle use can result in Severe Injury or Death.

NEVER Operate:

- At speeds too fast for your skills or the conditions.
- After or while using Alcohol or Drugs.
- On hills steeper than 15 degrees $\leq 15^\circ$.
- On public roads, a collision can occur with a another vehicle.
- With more than one passenger, or a passenger under age twelve or who cannot comfortably reach the floor and hand holds.
- On paved surfaces - pavement may seriously affect handling and control.
- With non-POLARIS approved accessories - they may seriously affect stability.

ALWAYS:

- Wear your seat belt. Vehicle rollover could cause severe injury or death.
- Wear a helmet and eye protection and keep hands and feet in vehicle at all times.
- Reduce speed and use extra caution when carrying passengers.
- Avoid sharp turns or turns while applying heavy throttle.
- Operate slowly in reverse - avoid sharp turns or sudden braking.
- Make sure passenger reads and understands all safety labels.
- Watch for branches or other hazards that could enter vehicle.

LOCATE AND READ OWNER'S MANUAL. FOLLOW ALL INSTRUCTIONS AND WARNINGS.

7176169

Safety Labels and Locations Discretionary Warning (Crew)

WARNING

Improper vehicle use can result in SEVERE INJURY or DEATH.

NEVER Operate:

- At speeds too fast for your skills or the conditions.
- After or while using Alcohol or Drugs.
- On hills steeper than 15 degrees $\leq 15^\circ$.
- On public roads, a collision can occur with a another vehicle.
- With more than three passengers, or passengers under age twelve or who cannot comfortably reach the floor and hand holds.
- On paved surfaces - pavement may seriously affect handling and control.
- With non-POLARIS approved accessories - they may seriously affect stability.

ALWAYS:

- Wear your seat belt. Vehicle rollover could cause severe injury or death.
- Wear a helmet and eye protection and keep hands and feet in vehicle at all times.
- Reduce speed and use extra caution when carrying passengers.
- Avoid sharp turns or turns while applying heavy throttle.
- Operate slowly in reverse - avoid sharp turns or sudden braking.
- Make sure passengers read and understand all safety labels.
- Watch for branches or other hazards that could enter vehicle.

LOCATE AND READ OWNER'S MANUAL. FOLLOW ALL INSTRUCTIONS AND WARNINGS

7176958

SAFETY

Operator Safety

WARNING

Serious injury or death can result if you do not follow these instructions and procedures, which are outlined in further detail within your owner's manual.

- Read this manual and all labels carefully. Follow the operating procedures described.
- Never allow anyone under age 16 to operate this vehicle and never allow anyone without a valid driver's license to operate this vehicle.
- Do not carry a passenger until you have at least two hours of driving experience with this vehicle.
- No person under the age of 12 may ride as a passenger in this vehicle. Any passenger must be able to comfortably reach the floor and hand holds.
- The driver and all passengers must wear helmet, eye protection and seat belt at all times.
- Always use the cab nets while riding in this vehicle.
- Always keep hands and feet inside the vehicle at all times.
- Always keep both hands on the steering wheel and both feet on the floorboards of the vehicle during operation.
- Never permit a guest to operate this vehicle unless the guest has read this manual and all product labels.
- To reduce tipover risk, be especially careful when encountering obstacles and slopes and when braking on hills or during turns.
- This vehicle is for off road use only. Never operate on public roads. Always avoid paved surfaces.
- Never consume alcohol or drugs before or while operating this vehicle.
- Never operate at excessive speeds. Always travel at a speed proper for the terrain, visibility and operating conditions, and your experience.
- Never attempt jumps or other stunts.

Operator Safety

- Always inspect your vehicle each time you use it to make sure it's in safe operating condition. Always follow the inspection and maintenance procedures and schedules described in this manual.
- Always travel slowly and use extra caution when operating on unfamiliar terrain. Be alert to changing terrain.
- Never operate on excessively rough, slippery or loose terrain.
- Always follow proper procedures for turning. Practice turning at slow speeds before attempting to turn at faster speeds. Never turn at excessive speeds.
- Always have this vehicle checked by an authorized POLARIS dealer if it has been involved in an accident.
- Never operate this vehicle on hills too steep for the vehicle or for your abilities. Practice on smaller hills before attempting larger hills.
- Always follow proper procedures for climbing hills as described in this manual. Check the terrain carefully before attempting to climb a hill. Never climb hills with excessively slippery or loose surfaces. Never open the throttle suddenly or make sudden gear changes. Never go over the top of a hill at high speed.
- Always follow the proper procedures outlined in this manual for traveling downhill and for braking on hills. Check the terrain carefully before descending a hill. Never travel downhill at high speed. Avoid going downhill at an angle, which would cause the vehicle to lean sharply to one side. Travel straight down the hill where possible.
- Always check for obstacles before operating in a new area. Never attempt to operate over large obstacles such as rocks or fallen trees. Always follow the proper procedures outlined in this manual when operating over obstacles.
- Always be careful of skidding or sliding. On slippery surfaces such as ice, travel slowly and exercise caution to reduce the chance of skidding or sliding out of control.

SAFETY

Operator Safety

- Never operate your vehicle in fast-flowing water or in water deeper than that specified in this manual. Wet brakes may have reduced stopping ability. Test your brakes after leaving water. If necessary, apply them lightly several times to let friction dry out the pads.
- Always be sure there are no obstacles or people behind your vehicle when operating in reverse. When it's safe to proceed in reverse, move slowly. Avoid turning at sharp angles in reverse.
- Always use the proper size and type of tires specified in this manual. Always maintain proper tire pressure as specified on safety labels.
- Never modify this vehicle through improper installation or use of accessories.
- Never exceed the stated load capacity for this vehicle. Cargo should be properly distributed and securely attached. Reduce speed and follow the instructions in this manual for hauling cargo or pulling a trailer. Allow a greater distance for braking.
- Always place the transmission in PARK before getting out of the vehicle.
- Always stop the engine before refueling. Remove flammable material containers from the box before filling them with fuel. Make sure the refueling area is well ventilated and free of any source of flame or sparks. Gasoline is extremely flammable. See page 17 for fuel safety warnings.
- Always remove the ignition key when the vehicle is not in use to prevent unauthorized use or accidental starting.

FOR MORE INFORMATION ABOUT SAFETY, call POLARIS at 1-800-342-3764.

Operator Safety

Equipment Modifications

We strongly recommend that consumers do not install on a POLARIS *RANGER* any equipment that may increase the speed or power of the vehicle, or make any other modifications to the vehicle for these purposes. Any modifications to the original equipment of the vehicle create a substantial safety hazard and increase the risk of bodily injury.

The warranty on your POLARIS *RANGER* is terminated if any equipment has been added to the vehicle, or if any modifications have been made to the vehicle, that increase its speed or power.

The addition of certain accessories, including (but not limited to) mowers, blades, tires, sprayers, or large racks, may change the handling characteristics of the vehicle. Use only POLARIS-approved accessories, and familiarize yourself with their function and effect on the vehicle.

SAFETY

Operator Safety

⚠ WARNING

Failure to operate the *RANGER* properly can result in a collision, loss of control, accident or overturn, which may result in serious injury or death. Heed all safety warnings outlined in this section of the owner's manual. See the OPERATION section of the owner's manual for proper operating procedures.

Age Restrictions

This vehicle is an **ADULT VEHICLE ONLY**. NEVER operate this vehicle if you are under age 16 and NEVER operate without a valid driver's license.

No person under the age of 12 may ride as a passenger in this vehicle. Any passenger must be able to comfortably reach the floor and hand holds.

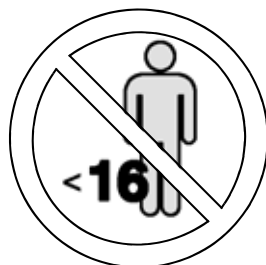

Operating Without Instruction

Operating this vehicle without proper instruction increases the risk of an accident. The operator must understand how to operate the vehicle properly in different situations and on different types of terrain.

All operators must read and understand the Owner's Manual and all warning and instruction labels before operating the vehicle.

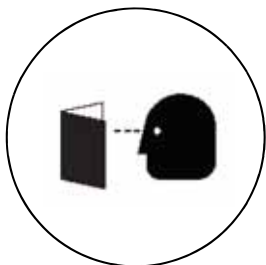

Seat Belts

Riding in this vehicle without wearing the seat belt increases the risk of serious injury in the event of an accident or sudden stop. Riders *must* wear seat belts at all times. Always make sure the seat belts are secured for both the operator and all passengers before riding.

Using Alcohol or Drugs

Operating the vehicle after consuming alcohol or drugs could adversely affect operator judgment, reaction time, balance and perception.

Never drink alcohol or use drugs or medications before or while operating this vehicle.



Operator Safety

Cab Nets

Riding in this vehicle without using the cab nets increases the risk of serious injury or death in the event of an accident or overturn. Always use the cab nets while riding in this vehicle.

Always keep hands and feet inside the vehicle at all times.

Failure to Inspect Before Operating

Failure to inspect and verify that the vehicle is in safe operating condition before operating increases the risk of an accident.

Always inspect your *RANGER* before each use to make sure it's in safe operating condition. Always follow all inspection and maintenance procedures and schedules described in the owner's manual.

Handling Gasoline

Gasoline is highly flammable and explosive under certain conditions.

- Always exercise extreme caution whenever handling gasoline.
- Always stop the engine when refueling.
- Remove flammable material containers from the box before filling them with fuel.
- Always refuel outdoors or in a well ventilated area.
- Do not smoke or allow open flames or sparks in or near the area where refueling is performed or where gasoline is stored.
- Do not overfill the tank. Do not fill the tank neck.
- If gasoline spills on your skin or clothing, immediately wash it off with soap and water and change clothing.

Exposure to Exhaust

Engine exhaust fumes are poisonous and can cause loss of consciousness or death in a short time. Never start the engine or let it run in an enclosed area.

The engine exhaust from this product contains chemicals known to cause cancer, birth defects or other reproductive harm. Operate this vehicle only outdoors or in well-ventilated areas.

Operating a Damaged Vehicle

Operating a damaged vehicle can result in an accident. After any overturn or accident, have a qualified service dealer inspect the entire machine for possible damage, including (but not limited to) brakes, throttle and steering systems.

Operating at Excessive Speeds

Operating this vehicle at excessive speeds increases the operator's risk of losing control. Always operate at a speed that's appropriate for the terrain, the visibility and operating conditions, and your experience.

SAFETY

Operator Safety

Operating on Pavement

This vehicle's tires are designed for off-road use only, not for use on pavement. Operating this vehicle on paved surfaces (including sidewalks, paths, parking lots and driveways) may adversely affect the handling of the vehicle and could result in loss of control and accident or overturn.

Avoid operating the vehicle on pavement. If it's unavoidable, travel slowly and avoid sudden turns or stops.

Operating on Public Roads

Operating this vehicle on public streets, roads or highways could result in a collision with another vehicle.

Never operate this vehicle on any public street, road or highway, including dirt and gravel roads. In some areas it's unlawful to operate this vehicle on public streets, roads and highways.

Turning Improperly

Turning improperly could cause loss of traction, loss of control, accident or overturn. Always follow proper procedures for turning. Never turn abruptly or at sharp angles. Never turn at high speeds. Practice turning at slow speeds before attempting to turn at faster speeds.

Jumps and Stunts

Attempting wheelies, jumps and other stunts increases the risk of an accident or overturn. Never attempt wheelies, jumps, or other stunts. Avoid exhibition driving.

Operating in Unfamiliar Terrain

Failure to use extra caution when operating on unfamiliar terrain could result in an accident or overturn. Unfamiliar terrain may contain hidden rocks, bumps, or holes that could cause loss of control or overturn.

Travel slowly and use extra caution when operating on unfamiliar terrain. Always be alert to changing terrain conditions.

Operating on Slippery Terrain

Failure to use extra caution when operating on excessively rough, slippery or loose terrain could cause loss of traction, loss of control, accident or overturn.

Do not operate on excessively slippery surfaces. Always reduce speed and use additional caution when operating on slippery surfaces.

Operator Safety

Improper Hill Climbing

Climbing hills improperly can cause loss of control or vehicle overturn. Always follow proper procedures for climbing hills as described in the owner's manual. See page 46.

Stalling While Climbing a Hill

Stalling or rolling backwards while climbing a hill could cause an overturn. Always maintain a steady speed when climbing a hill.

If all forward speed is lost:

- Apply the brakes.
- Place the transmission in reverse and slowly allow the vehicle to roll straight downhill while applying light brake pressure to control speed.

If you begin rolling downhill:

- Never apply engine power.
- Apply the brakes gradually until the vehicle is fully stopped.
- Place the transmission in reverse and slowly allow the vehicle to roll straight downhill while applying light brake pressure to control speed.

Improper Tire Maintenance

Operating this vehicle with improper tires or with improper or uneven tire pressure could cause loss of control or accident. Always use the size and type of tires specified for your vehicle. Always maintain proper tire pressure as described in the owner's manual and on safety labels.

Operating on Frozen Bodies of Water

Severe injury or death can result if the vehicle and/or the operator fall through the ice. Never operate the vehicle on a frozen body of water unless you have first verified that the ice is sufficiently thick to support the weight and moving force of the vehicle, you and your passengers, and your cargo, together with any other vehicles in your party. Always check with local authorities and residents to confirm ice conditions and thickness over your entire route. Vehicle operators assume all risk associated with ice conditions on frozen bodies of water.

Unauthorized Use of the Vehicle

Leaving the keys in the ignition can lead to unauthorized use of the vehicle, which could result in an accident or overturn. Always remove the ignition key when the vehicle is not in use.

Hot Exhaust Systems

Exhaust system components are very hot during and after use of the vehicle. Hot components can cause burns and fire. Do not touch hot exhaust system components. Always keep combustible materials away from the exhaust system. Use caution when traveling through tall grass, especially dry grass.

FEATURES AND CONTROLS

Component Locations

Your vehicle is equipped with cab nets on both sides of the vehicle. Cab nets must be used by both operator and passengers at all times. The vehicle illustrated below is shown without cab nets only to allow component identification. Always use the cab nets.

Not all models come with all features. Refer to the specifications section beginning on page 104.

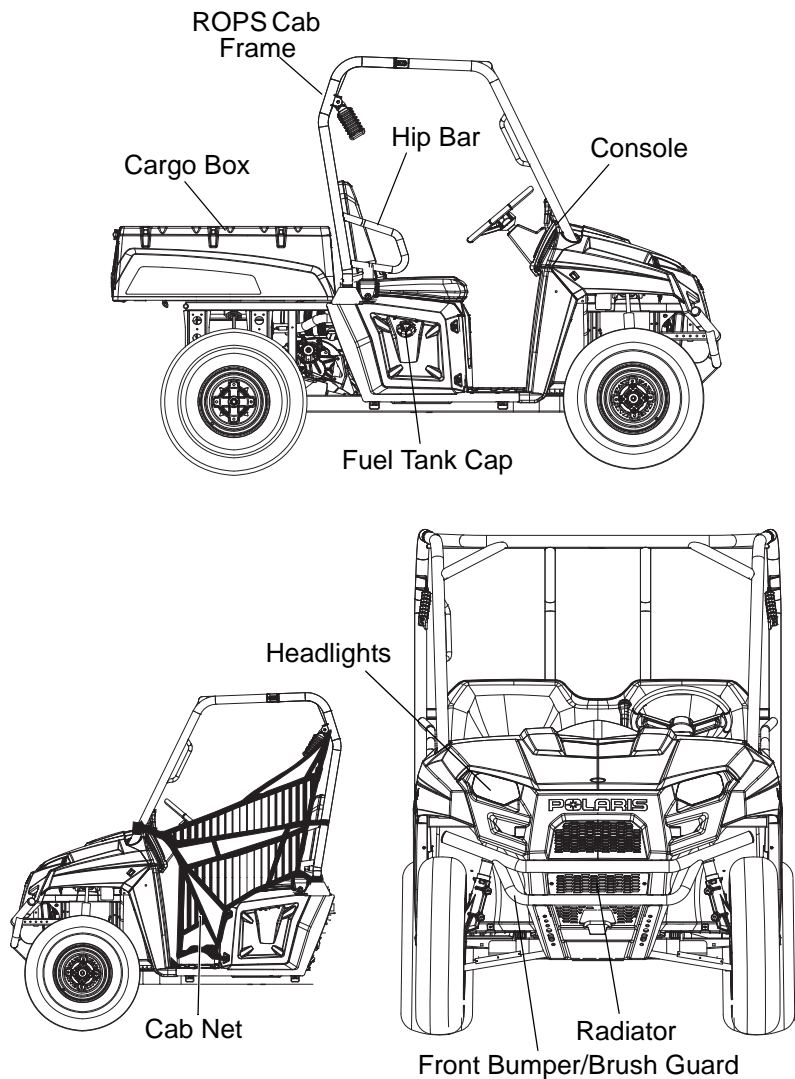

FEATURES AND CONTROLS

Component Locations

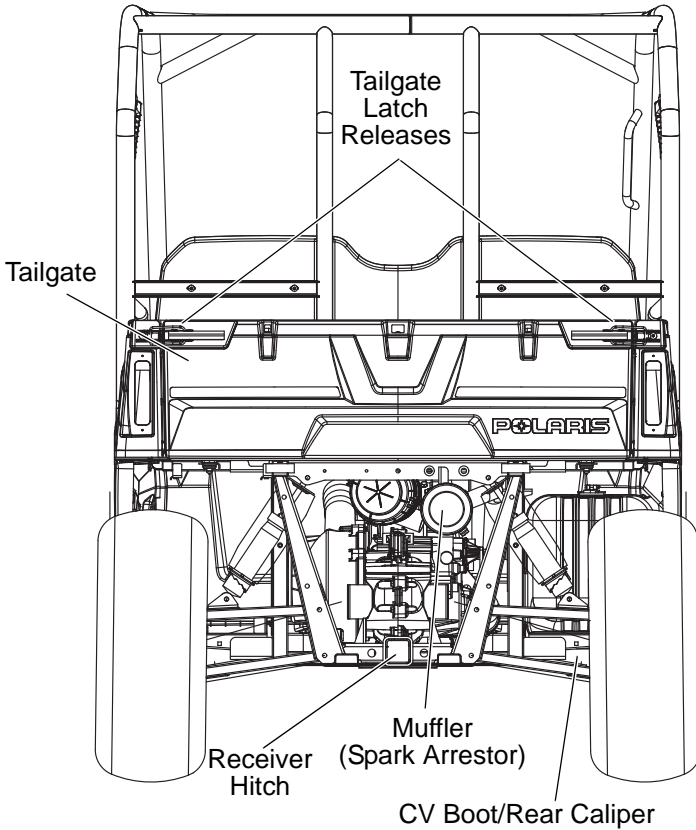

Trailer Hitch Bracket

This vehicle is equipped with a receiver hitch bracket for a trailer hitch. Trailer towing equipment is not supplied with this vehicle.

To avoid injury and property damage, always heed the warnings and towing capacities outlined on pages 52-55.

FEATURES AND CONTROLS

Console

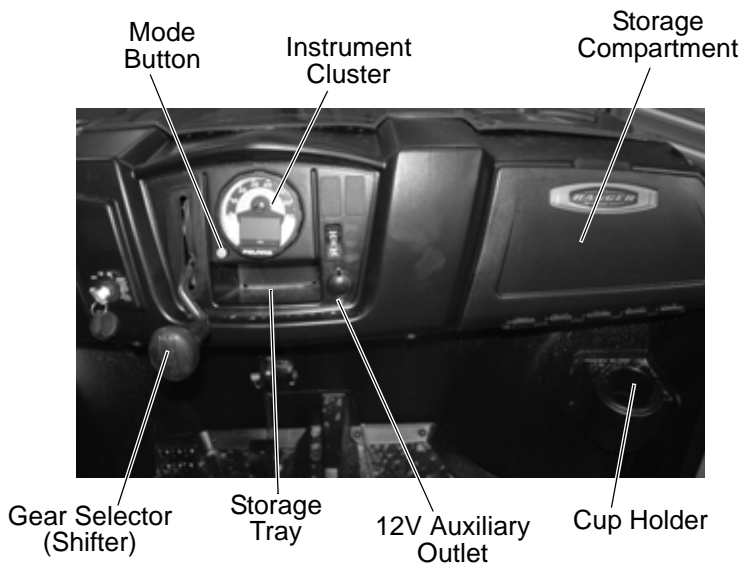

Auxiliary Outlet

The 12-volt receptacle has spade connections on the back that may be used to power an auxiliary light or other optional accessories or lights. The connections are behind the console, under the hood.

FEATURES AND CONTROLS

Console

Mode Button

The yellow button located near the instrument cluster is used to toggle through mode options available. See pages 33-36.

Gear Selector

H: High Gear

L: Low Gear

N: Neutral

R: Reverse

P: Park

Low gear is the primary driving range for the *RANGER*. High gear is intended for use on hard-packed surfaces with light loads.

Whenever the vehicle is left unattended, always place the transmission in **PARK**.

To change gears, stop the vehicle, and with the engine idling, move the lever to the desired gear. Do not attempt to shift gears with engine speed above idle or while the vehicle is moving.

Tip: Maintaining shift linkage adjustment is important to assure proper transmission function. See your dealer if you experience any shifting problems.

NOTICE: Do not attempt to shift the transmission while the vehicle is moving or damage to the transmission could result. Always shift when the vehicle is stationary and the engine is at idle.

Gear Selector



FEATURES AND CONTROLS

Switches



Ignition Switch
Light Switch

AWD/Differential
Switch

Ignition Switch/Light Switch

The ignition switch is a four-position, key-operated switch. The key can be removed from the switch when it is in the OFF position.



OFF	The engine is off. Electrical circuits are off, except Acc, 12V.
LIGHTS ON	Lights are on. Electrical circuits are on. Electrical equipment can be used.
LIGHTS OFF	Lights are off. Electrical circuits are on. Electrical equipment can be used.
START	Turn the key to the START position to engage the electric starter. Turn the key to the LIGHTS ON position after starting the engine.

FEATURES AND CONTROLS

Switches

AWD/Differential Lock Switch

The AWD/Differential Switch has three positions: All Wheel Drive (AWD), Differential Lock/Two Wheel Drive (2WD) and Off (1WD/Turf Mode).

Press the top of the rocker switch to engage All Wheel Drive (AWD). See page 57 for AWD operating instructions.

Move the rocker switch to the center position to lock the differential and operate in two wheel drive (2WD). See page 56 for Differential Lock operating instructions.

Press the bottom of the switch to unlock the differential and allow the rear drive wheels to operate independently (1WD). This mode of operation is well suited to turf driving or when active traction is not needed.

Brake Pedal

Depress the brake pedal to slow or stop the vehicle. Apply the brakes while starting the engine.

Throttle Pedal

Push the pedal down to increase engine speed. Spring pressure returns the pedal to the rest position when released. Always check that the throttle pedal returns normally before starting the engine. Make sure there's adequate throttle pedal freeplay. See page 85 for throttle pedal adjustment procedures.

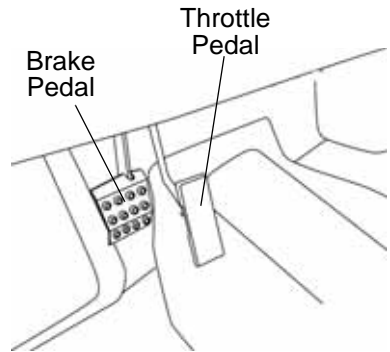

FEATURES AND CONTROLS

Seat Belts

This POLARIS vehicle is equipped with three-point lap and diagonal seat belts on all external seats. The center seat is equipped with a lap-style seat belt. Always make sure the seat belts are secured for all riders before operating.

WARNING! Falling from a moving vehicle could result in serious injury or death. Always fasten your seat belt securely before operating or riding in the *RANGER*.

To wear the seat belt properly, follow this procedure:

1. For 3-point belts, pull the seat belt latch downward and across your chest toward the buckle at the inner edge of the seat. The belt should fit snugly across your hips and diagonally across your chest. Make sure the belt is not twisted. For lap style belts, place the belt across your lap as low on your hips as possible. Make sure that the belt is not twisted.
2. Push the latch plate into the buckle until it clicks.
3. Release the strap, it will self tighten.

Tip: The center belt must be tightened manually by pulling on the strap.

4. To release the seat belt, press the square red button in the buckle's center.

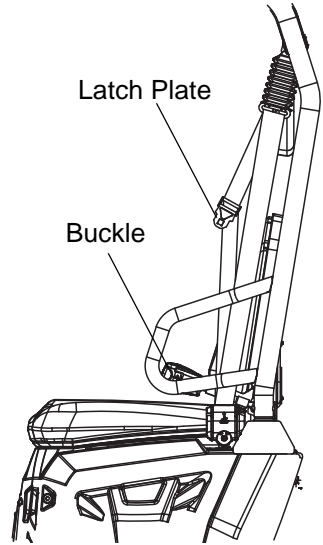

FEATURES AND CONTROLS

Seat Belts

Seat Belt Inspection

Inspect all seat belts for proper operation before each use of the vehicle.

1. Push the latch plate into the buckle until it clicks. The latch plate must slide smoothly into the buckle. A click indicates that it's securely latched.
2. Push the red release latch in the middle of the buckle to make sure it releases freely.
3. Pull each seat belt completely out and inspect the full length for any damage, including cuts, wear, fraying or stiffness. If any damage is found, or if the seat belt does not operate properly, have the seat belt system checked and/or replaced by an authorized POLARIS dealer.
4. To clean dirt or debris from the seat belts, sponge the straps with mild soap and water. Do not use bleach, dye or household detergents.

FEATURES AND CONTROLS

Cab Nets

Riding in this vehicle without using the cab nets increases the risk of serious injury or death in the event of an accident or overturn. Cab nets must be used by both operator and passengers at all times. Make sure all latches are secure before operating the vehicle.

Always inspect cab nets for tightness, wear and damage before each use of the vehicle. Use the strap adjusters to tighten any loose straps.

Promptly replace worn or damaged cab nets with new cab nets, available from your authorized Polaris dealer.

Securing a Net

1. After entering the vehicle, insert the lower net rod into the net mount on the floor. Make sure the ball at the end of the rod is properly secured in the slot at the base of the mount.
2. Connect the latch at the top edge of the net to the receiver latch mounted on the front frame.

Opening a Net

1. To exit the vehicle, release the top front latch.
2. Rotate the net rearward and slide the lower net rod out of the mount to remove it.
3. Allow the net to hang freely outside the vehicle while dismantling.

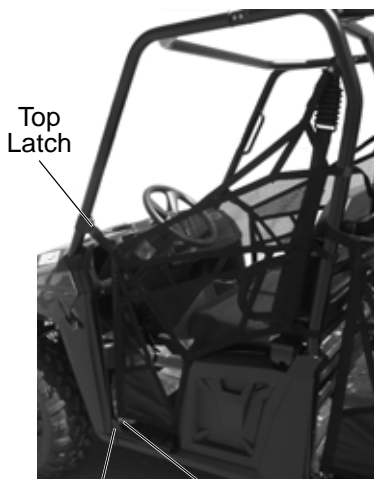

Rod Mount

Net Rod



Net Rod

FEATURES AND CONTROLS

Seat Removal

Pull up on the front of the seat and slide it toward the front of the vehicle. Install the seat by sliding the tabs into the rear of the seat base. Push down firmly on the front of the seat until the pins are fully seated into the grommets.

Fuel Cap

The fuel tank filler cap is located on the right-hand side of the vehicle near the passenger seat. When refueling, always use either leaded or unleaded gasoline with a minimum pump octane number of 87 R+M/2 octane. *Do not use fuel with ethanol content greater than 10 percent, such as E-85 fuel.*

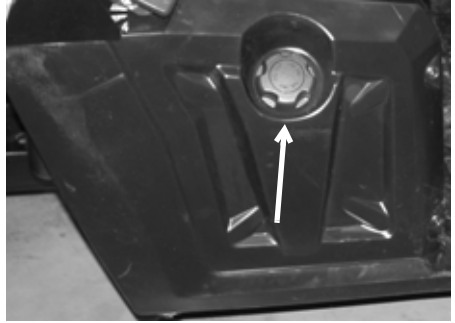

FEATURES AND CONTROLS

Rollover Protective Structure (ROPS)

The Rollover Protective Structure (ROPS) on this vehicle meets OSHA 1928.53 rollover performance requirements. Always have your authorized POLARIS dealer thoroughly inspect the ROPS if it ever becomes damaged in any way.

No device can assure occupant protection in the event of a rollover.

Always follow all safe operating practices outlined in this manual to avoid vehicle rollover.

WARNING! Vehicle rollover could cause severe injury or death. Always avoid operating in a manner that could result in vehicle rollover.

Storage Compartments

A storage compartment is located under the driver's seat on Crew models.

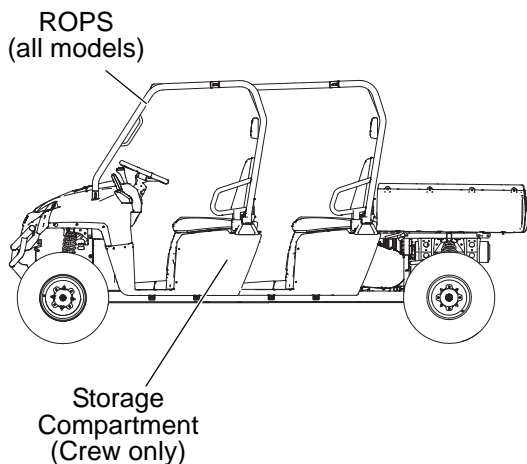

FEATURES AND CONTROLS

Instrument Cluster

The instrument cluster measures distance traveled by the vehicle, as well as time, hours of operation and engine RPM.

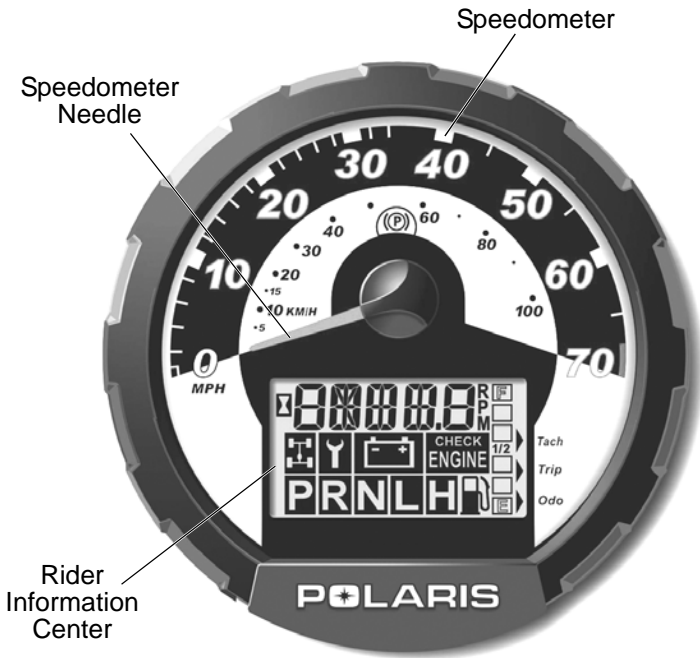

Tip: In addition to showing vehicle speed, the speedometer needle flashes when a low fuel condition exists.

FEATURES AND CONTROLS

Instrument Cluster

Rider Information Center

The rider information center is located in the instrument cluster. All segments will light up for 2.5 seconds at start-up.

Tip: If the instrument cluster fails to illuminate, a battery over-voltage may have occurred and the instrument cluster may have shut off to protect the electronic speedometer. If this occurs, take the vehicle to your Polaris dealer for proper diagnosis.

1. **Gear Indicator** - This indicator displays gear shifter position.
H = High Gear
L = Low Gear
N = Neutral
R = Reverse Gear
P = Park

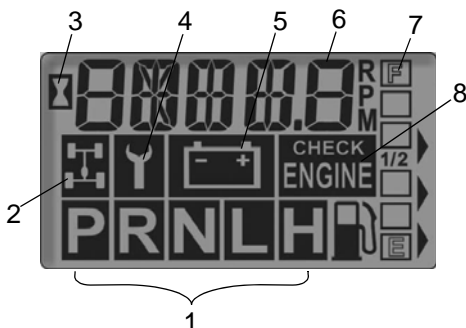

2. **AWD Indicator** - This indicator illuminates when the AWD switch is in the AWD position.
3. **Engine Hour Display Indicator**
4. **Service Interval/Diagnostic Mode Indicator**
5. **Low Battery and Over Voltage** - This warning usually indicates that the vehicle is operating at an RPM too low to keep the battery charged. It may also occur when the engine is at idle and high electrical load (lights, cooling fan, accessories) is applied. Drive at a higher RPM or recharge the battery to clear the warning.
6. **Odometer/Tachometer/Tripmeter/ Hour Meter**
7. **Fuel Gauge** - The segments of the fuel gauge show the level of fuel in the fuel tank. When the last segment clears, a low fuel warning is activated. All segments will flash, FUEL will display in the LCD, and the speedometer needle will blink. Refuel immediately.
8. **Check Engine Warning Indicator** - This indicator serves two purposes. The word HOT displays if the engine overheats. It also appears if an EFI-related fault occurs. Do not operate the vehicle if this warning appears. Serious engine damage could result.

FEATURES AND CONTROLS

Instrument Cluster

Rider Information Center

Standard Modes

Use the yellow mode button located under the speedometer to toggle through the mode options. See page 22.

Odometer Mode

The odometer records the miles traveled by the vehicle.

Trip Meter Mode

The trip meter records the miles traveled by the vehicle on each trip if it's reset before each trip. To reset the trip meter, select the trip meter mode. Press and hold the mode button until the total changes to 0.

Tip: In the Rider Information Center, the trip meter display contains a decimal point, but the odometer displays without a decimal point.

Hour Meter Mode

This mode logs the total hours the engine has been in operation.

Tachometer Mode

The engine RPM is displayed digitally. Small fluctuations in the RPM from day to day may be normal because of changes in humidity, temperature and elevation.

FEATURES AND CONTROLS

Instrument Cluster

Rider Information Center

Diagnostic Mode

The wrench icon will display when the gauge is in the diagnostic mode. To exit the diagnostic mode, turn the key switch off and on. Any movement of the tires will also cause the gauge to exit the diagnostic mode.

To enter the diagnostics mode:

1. Turn the key switch off and wait 10 seconds.
2. Place the transmission in PARK.
3. Hold the mode button and turn the key switch on. Release the switch as soon as the display is activated.
4. Use the mode button to toggle through the diagnostic screens.

FEATURES AND CONTROLS

Instrument Cluster

Rider Information Center

Diagnostic Mode

Battery Voltage Screen

View this screen to check battery voltage level.

Tachometer Screen

View the tachometer to check engine speed.

AWD Diagnostic Screen

The gauge indicates whether or not current is flowing through the AWD coil (only on models with switchable AWD). This screen is for informational purposes only. Please see your dealer for all major repairs.

Gear Circuit Diagnostic Screen

This screen displays the resistance value (in ohms) being read at the gear switch input of the gauge. This screen is for informational purposes only. Please see your dealer for all major repairs.

Programmable service interval

When the hours of engine operation equal the programmed service interval setting, the wrench icon will flash for 5 seconds each time the engine is started. When this feature is enabled, it provides a convenient reminder to perform routine maintenance. See page 36.

The service interval is programmed at 50 hours at the factory.

FEATURES AND CONTROLS

Instrument Cluster

Rider Information Center

Diagnostic Mode

Programmable service interval

To enable or disable the service interval:

1. Enter the diagnostic mode.
2. Toggle to the service interval screen.
3. Press and hold the mode button for about seven (7) seconds, until either ON or OFF appears in the Rider Information Center, depending on your preference.

To reset the service interval:

1. Enter the diagnostic mode.
2. Toggle to the service interval screen.
3. Press and hold the mode button for 2-3 seconds, until the wrench icon flashes. Release the button.
4. Press and release the mode button once to advance the setting by one hour. Press and *hold* the mode button to advance the hours quickly. If you scroll past the intended number, press and hold the button until the hours cycle back to zero.
5. When the desired setting is displayed, wait until the wrench icon stops flashing. The new service interval is now programmed.

Miles/Kilometers toggle

The display in the tripmeter and odometer can be changed to display either standard or metric units of measurement.

1. Enter the diagnostic mode.
2. Toggle to the screen that displays either kilometers (KM) or miles (MP).
3. Press and hold the mode button until the letters flash, then press and release the button once. When the display stops flashing, the mode has been set.

FEATURES AND CONTROLS

Instrument Cluster

Rider Information Center

Accessing Blink Codes

The EFI diagnostic mode is for informational purposes only. Please see your Polaris dealer for all major repairs.

See page 38 for Blink Codes and Failure Descriptions. Use the following procedure to access blink codes (failure codes) from the EFI module.

1. Apply the brakes.
2. Place the transmission in PARK.
3. Stop the engine.
4. Turn the key switch to the ON position.
5. Turn the key switch off and on three times in less than five seconds, then leave the switch on. Any blink code numbers stored in the EFI module will display, one at a time, on the screen. The number “61” and the word “END” displays after all codes have been transmitted.

FEATURES AND CONTROLS

Instrument Cluster

Rider Information Center

Blink Code Descriptions

Blink Code	Failure Description
--	No RPM Signal
21	Loss of Synchronization
45	Barometric Pressure Sensor: Circuit Low Input
46	Barometric Pressure Sensor: Circuit High Input
22	TPS: Open or Short Circuit to Ground
22	TPS: Short Circuit to Battery
23	RAM Error: Defective ECU
42	Engine Temp Sensor Circuit: Short to Ground
42	Engine Temp Sensor Circuit: Open or Short to Battery
51	Injector 1: Open Load
51	Injector 1: Short Circuit to Ground
51	Injector 1: Short Circuit to Battery
52	Injector 2: Open Load
52	Injector 2: Short Circuit to Ground
52	Injector 2: Short Circuit to Battery
53	Rear Differential: Open Load (<i>RANGER 4X4</i> only)
53	Rear Differential: Short Circuit to Ground (<i>RANGER 4X4</i> only)
53	Rear Differential: Short Circuit to Battery (<i>RANGER 4X4</i> only)
54	Engine Temp Lamp: Open Load
54	Engine Temp Lamp: Short Circuit to Ground
54	Engine Temp Lamp: Short Circuit to Battery
55	Diag Lamp: Open Load
55	Diag Lamp: Short Circuit to Ground
55	Diag Lamp: Short Circuit to Battery
56	Pump Relay: Open Load
56	Pump Relay: Short Circuit to Ground
56	Pump Relay: Short Circuit to Battery
57	Reverse Beeper: Open Load
57	Reverse Beeper: Short Circuit to Ground
57	Reverse Beeper: Short Circuit to Battery
58	Cooling Fan: Open Load
58	Cooling Fan: Short Circuit to Ground
58	Cooling Fan: Short Circuit to Battery
41	Intake Air Temp Sensor: Open or Short Circuit to +Sensor Voltage
41	Intake Air Temp Sensor: Short Circuit to Ground
61	END

WARNING

Failure to operate the vehicle properly can result in a collision, loss of control, accident or overturn, which may result in serious injury or death. Read and understand all safety warnings outlined in the safety section of this owner's manual.

Break-In Period

The break-in period for your new POLARIS *RANGER* is the first twenty hours of operation, or the time it takes to use the first two tanks full of gasoline. No single action on your part is as important as a proper break-in period. Careful treatment of a new engine will result in more efficient performance and longer life for the engine. Perform the following procedures carefully.

NOTICE: Excessive heat build-up during the first three hours of operation will damage close-fitted engine parts. Do not operate at full throttle or high speeds for extended periods during the first three hours of use.

OPERATION

Break-In Period

Engine and Drivetrain Break-in

1. Fill the fuel tank with gasoline. Heed the gasoline warnings on page 17.
2. Check the oil level. See page 65. Add the recommended oil as needed to maintain the oil level in the normal (safe) operating range.
3. Drive slowly at first. Select an open area that allows room to familiarize yourself with vehicle operation and handling.
4. Vary throttle positions. Do not operate at sustained idle.
5. Perform regular checks on fluid levels, controls and areas outlined on the daily pre-ride inspection checklist. See page 41.
6. Pull only light loads.
7. During the break-in period, change both the oil and the filter at 25 hours.

PVT Break-in (Clutches/Belt)

A proper break-in of the clutches and drive belt will ensure a longer life and better performance. Break in the clutches and belt by operating at slower speeds during the break-in period as recommended. Pull only light loads. Avoid aggressive acceleration and high speed operation during the break-in period.

Pre-Ride Inspection

Failure to inspect and verify that the vehicle is in safe operating condition before operating increases the risk of an accident. Always inspect the vehicle before each use to make sure it's in safe operating condition.

Item	Remarks	Page
Brake system/pedal travel	Ensure proper operation	25 86
Brake fluid	Ensure proper level	86
Park gear	Ensure vehicle does not roll when in PARK. Ensure PARK light illuminates.	-
Front suspension	Inspect, lubricate if necessary	63
Rear suspension	Inspect, lubricate if necessary	63
Steering	Ensure free operation	87
Tires	Inspect condition and pressure	7 88
Wheels/fasteners	Inspect, ensure fastener tightness	88
Frame nuts, bolts, fasteners	Inspect, ensure tightness	-
Fuel and oil	Ensure proper levels	29 65
Coolant level	Ensure proper level	75 76
Coolant hoses	Inspect for leaks	-
Throttle	Ensure proper operation	84
Indicator lights/switches	Ensure operation	24
Air filter, pre-filter	Inspect, clean	80
Air box sediment tube	Drain deposits whenever visible	80
Headlamp	Check operation, apply POLARIS dielectric grease when lamp is replaced	90
Brake light/tail lamp	Check operation, apply POLARIS dielectric grease when lamp is replaced	91
Seat Belts	Check length of belt for damage, check latches for proper operation	27
Cab Nets	Check for wear or damage, ensure proper installation	28

OPERATION

Starting Engine

1. Always start the engine outdoors or in a well-ventilated area.
2. Sit in the driver's seat and fasten the seat belt. Secure the cab nets.
3. Apply the brakes. Place the transmission in PARK.
4. Do not press the throttle pedal while starting the engine. Turn the ignition key past the ON/RUN position to START. Engage the starter for a maximum of five seconds. Release the key when the engine starts.
5. If the engine does not start within five seconds, release the ignition switch and wait five seconds. Repeat steps 4 and 5 until the engine starts.
6. Vary the engine RPM slightly with the throttle to aid in warm up until the engine idles smoothly.

NOTICE: Operating the vehicle immediately after starting could cause engine damage. Allow the engine to warm up for several minutes before operating the vehicle.

Stopping the Engine

1. Release the throttle pedal completely and brake to a complete stop.
2. Turn the engine off.
3. Place the transmission in PARK.

WARNING! A rolling vehicle can cause serious injury. Always place the transmission in PARK when stopping the engine.

Braking

1. Release the throttle pedal completely.
2. Press on the brake pedal evenly and firmly.
3. Practice starting and stopping (using the brakes) until you're familiar with the controls.

Tip: When the throttle pedal is released completely and the engine speed drops near an idle, the vehicle has no engine braking.

Driving Procedure

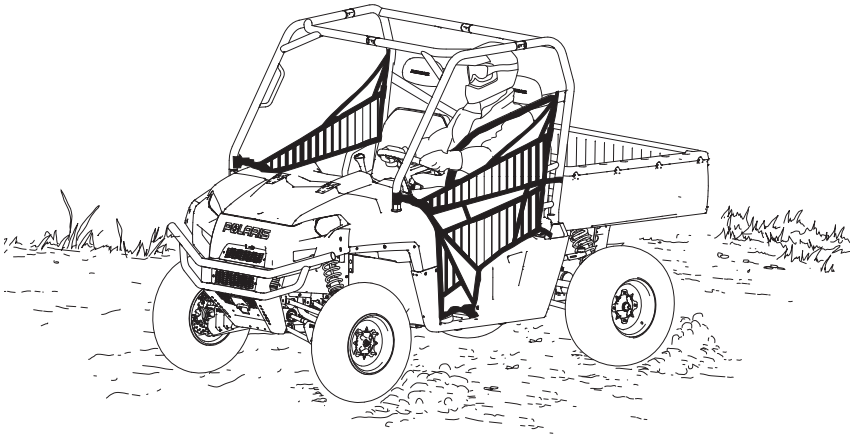

1. Wear a helmet and eye protection.
2. Sit in the driver's seat and fasten the seat belt.
3. Start the engine and allow it to warm up.
4. Always use the cab nets while riding in this vehicle.
5. Apply the service brakes and shift the transmission into gear.
6. Check your surroundings and determine your path of travel.
7. Keeping both hands on the steering wheel, slowly release the brakes and depress the throttle with your right foot to begin driving.
8. Drive slowly. Practice maneuvering and using the throttle and brakes on level surfaces.
9. Do not carry a passenger until you have at least two hours of driving experience with this vehicle.

OPERATION

Driving with a Passenger

1. Perform the pre-ride inspection. See page 41.
2. Make sure all passengers are at least 12 years of age and tall enough to comfortably and safely sit in a passenger seat with the seat belt secured, put both feet on the floor and grasp the hand hold.
3. Make sure all passengers are wearing an approved helmet and eye protection.
4. Make sure all passengers secure their seat belt.
5. Make sure all cab nets are properly secured.
6. Do not carry more than the recommended number of passengers for your vehicle. See pages 10-11.
7. Allow a passenger to ride only in a passenger seat.
8. Slow down. Always travel at a speed appropriate for your skills, your passengers' skills, and operating conditions. Avoid unexpected or aggressive maneuvers that could cause discomfort or injury to a passenger.
9. Vehicle handling may change with a passenger and/or cargo on board. Allow more time and distance for braking.
10. Always follow all operating guidelines as outlined on safety labels and in this manual.

Driving On Slippery Surfaces

⚠ WARNING

Skidding or sliding can cause loss of control or overturn (if tires regain traction unexpectedly). When operating on slippery surfaces such as ice or loose gravel, reduce speed and use extra caution to reduce the chance of skidding or sliding out of control. Do not operate on excessively slippery surfaces.

Whenever riding on slippery surfaces such as wet trails or loose gravel, or during freezing weather, follow these precautions:

1. Do not operate on excessively rough, slippery or loose terrain.
2. Slow down before entering slippery areas.
3. Maintain a high level of alertness, reading the trail and avoiding quick, sharp turns, which can cause skids.
4. Engage all-wheel drive before wheels begin to lose traction.

NOTICE: Severe damage to the drive train may occur if the AWD is engaged while the wheels are spinning. Always allow the wheels to stop spinning before engaging AWD.

5. Correct a skid by turning the steering wheel in the direction of the skid. *Never apply the brakes during a skid.*

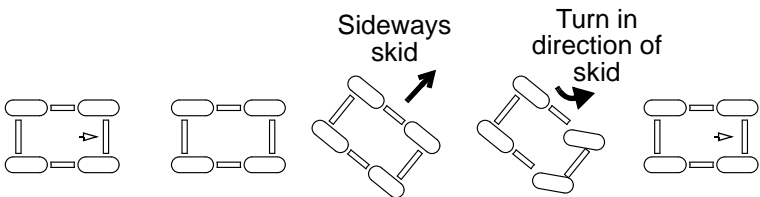

OPERATION

Driving Uphill

Whenever traveling uphill, follow these precautions:

1. Always travel straight uphill.
2. Avoid steep hills (15° maximum).
3. Keep both feet on the floor.
4. Always check the terrain carefully before ascending any hill.
5. Never climb hills with excessively slippery or loose surfaces.
6. Proceed at a steady rate of speed and throttle opening. Never open the throttle suddenly.
7. Never go over the crest of a hill at high speed. An obstacle, a sharp drop, or another vehicle or person could be on the other side of the hill.

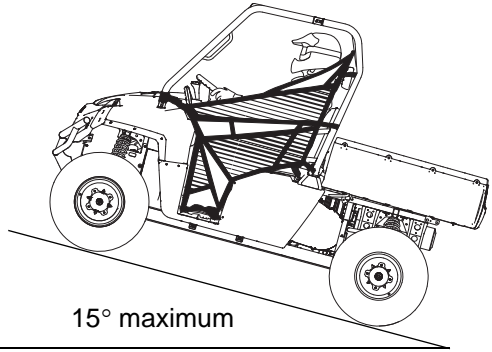

Driving on a Sidehill (Sidehilling)

Driving on a sidehill is not recommended. Improper procedure could cause loss of control or overturn. Avoid crossing the side of any hill unless absolutely necessary.

If crossing a sidehill is *unavoidable*, follow these precautions:

1. Slow down.
2. Exercise extreme caution.
3. Avoid crossing the side of a steep hill (15° maximum).

Driving Downhill

When driving downhill, follow these precautions:

1. Avoid steep hills (15° maximum).
2. Drive straight downhill. Avoid descending a hill at an angle, which would cause the vehicle to lean sharply to one side. Travel straight downhill when possible.
3. Slow down.
4. Apply the brakes *slightly* to aid in slowing.

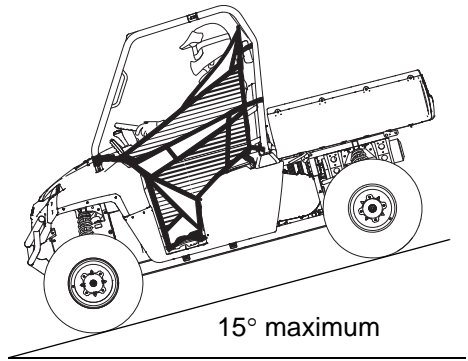

OPERATION

Driving Through Water

Your POLARIS *RANGER* can operate through water up to a maximum recommended depth equal to the floorboards.

NOTICE: Immersion can result in major damage if the vehicle isn't serviced correctly and promptly. After immersion, always take the vehicle to your dealer service. Do not start the engine! If it's impossible to bring the vehicle to your dealer before starting the engine, perform the service outlined on page 79, and take the vehicle to your dealer at the first opportunity.

Follow these procedures when operating through water:

1. Determine water depths and current before entering water.
2. Choose a crossing where both banks have gradual inclines.
3. Proceed slowly, avoiding rocks and obstacles.
4. Avoid operating through deep or fast-flowing water.

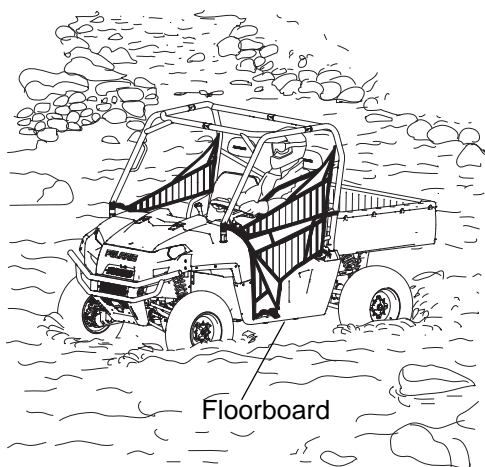

WARNING! The large tires on your *RANGER* may cause the vehicle to float in deep or fast-flowing water, which could result in loss of control and lead to serious injury or death. Never cross deep or fast-flowing water with your *RANGER*.

5. After leaving water, always dry the brakes by applying light pressure to the pedal repeatedly until braking action is normal.

NOTICE: After running your vehicle in water, it's critical that you perform the services outlined in the Periodic Maintenance Chart beginning on page 59. Give special attention to engine oil, transmission oil, front and rear gearcases (if equipped), and all grease fittings.

Driving Over Obstacles

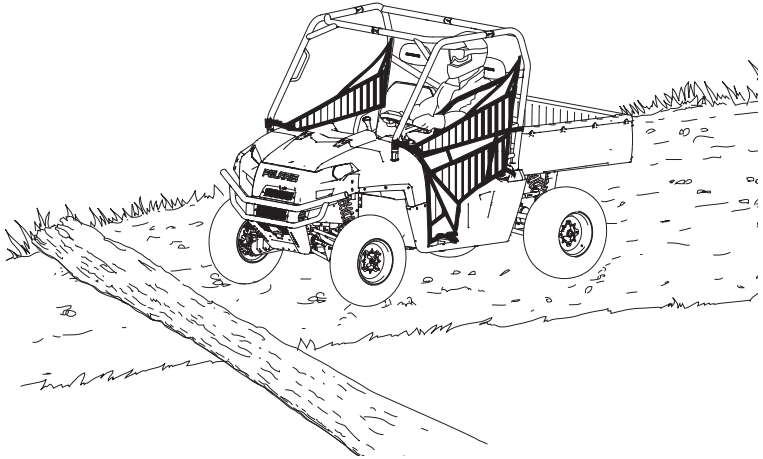

Follow these precautions when operating over obstacles:

1. Always check for obstacles before operating in a new area.
2. Look ahead and learn to read the terrain. Be constantly alert for hazards such as logs, rocks and low hanging branches.
3. Travel slowly and use extra caution when operating on unfamiliar terrain. Not all obstacles are immediately visible.

OPERATION

Driving in Reverse

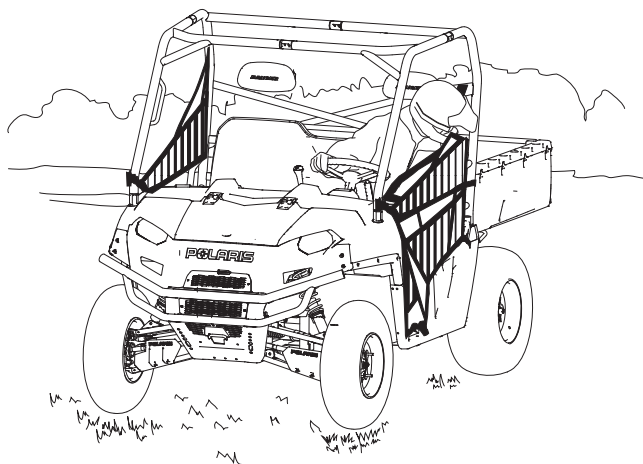

Follow these precautions when operating in reverse:

1. Always check for obstacles or people behind the vehicle. Always inspect left and right fields of vision before backing.
2. Always avoid backing downhill.
3. Back slowly.
4. Apply the brakes *lightly* for stopping.
5. Avoid turning at sharp angles.
6. Never open the throttle suddenly.

Parking the Vehicle

1. Apply the brakes. Stop the vehicle on a level surface.
2. When parking inside a garage or other structure, be sure that the structure is well ventilated and that the vehicle is not close to any source of flame or sparks, including any appliance with pilot lights.
3. Place the transmission in PARK.
4. Turn the engine off.
5. Remove the ignition switch key to prevent unauthorized use.

Parking on an Incline

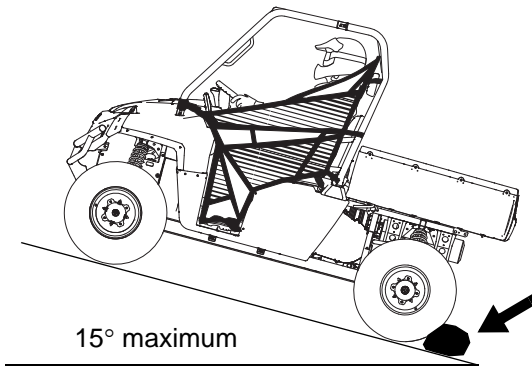

Avoid parking on an incline if possible. If it's unavoidable, follow these precautions:

1. Apply the brakes.
2. Place the transmission in PARK.
3. Turn the engine off.
4. Block the rear wheels on the downhill side.

OPERATION

Hauling Cargo

WARNING

Hauling cargo improperly can alter vehicle handling and may cause loss of control or brake instability, which can result in serious injury or death. Always follow these precautions when hauling cargo:

Never exceed the maximum weight capacity of the vehicle. When determining the weight you are adding to the vehicle, include the weight of the operator, passenger, accessories, loads in the rack or box and the load on the trailer tongue. The combined weight of these items must not exceed the maximum weight capacity.

REDUCE SPEED AND ALLOW GREATER DISTANCES FOR BRAKING WHEN HAULING CARGO.

Always load the cargo box with the load as far forward and as low as possible.

When operating over rough or hilly terrain, reduce speed and cargo to maintain stable driving conditions.

Always operate the vehicle with extreme care when hauling or towing loads.

Slow down and drive in the lowest gear available.

SECURE ALL LOADS BEFORE OPERATING. Unsecured loads can create unstable operating conditions, which could result in loss of control of the vehicle.

OPERATE ONLY WITH STABLE AND SAFELY ARRANGED LOADS. When handling off-centered loads that cannot be centered, securely fasten the load and operate with extra caution. Always attach the tow load to the hitch point designated for your vehicle.

HEAVY LOADS CAN CAUSE BRAKING AND CONTROL PROBLEMS. Use extreme caution when applying brakes with a loaded vehicle. Avoid terrain or situations that may require backing downhill.

USE EXTREME CAUTION when operating with loads that extend over the rack sides. Stability and maneuverability may be adversely affected, causing the vehicle to overturn.

DO NOT TRAVEL FASTER THAN THE RECOMMENDED SPEEDS. Vehicle should never exceed 10 mph (16 kph) while towing a load on a level grass surface. Vehicle speed should never exceed 5 mph (8 kph) when towing loads in rough terrain, while cornering, or while ascending or descending a hill.

Hauling Cargo

The *RANGER* has been designed to carry or tow specific capacities. Always read and understand the load distribution warnings listed on the warning labels. The total load (operator, passenger, accessories, cargo and weight on hitch) must not exceed the maximum weight capacity of the vehicle. Never exceed the following capacities.

Model	Maximum Capacities (Level Ground)	Cargo Box
4X4	1000 lbs. (455 kg)	500 lbs. (227 kg)
CREW	1250 lbs. (567 kg)	500 lbs. (227 kg)

WARNING! Driving with passengers in the cargo box can result in severe injury or death. Never allow passengers to ride in the cargo box. Passengers must always ride in the cab with seat belts fastened securely.

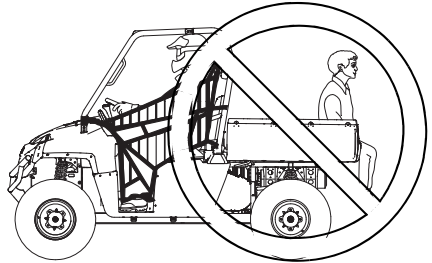

OPERATION

Dumping the Cargo Box

1. Select a level site to dump the cargo box. Do not attempt to dump or unload the vehicle while parked on an incline.
2. Apply the brakes.
3. Place the transmission in PARK.
4. Dismount the vehicle.
5. Ensure that the cargo is positioned evenly or toward the front of the cargo box.
6. Release the tailgate latches.



WARNING! If the weight distribution on the box is located toward the rear of the box when the release lever is pulled forward, the box may dump unexpectedly and cause serious injury to the operator or bystanders. Never operate the dump lever without ensuring that the load is positioned evenly or at the front of the box.

7. Stand clear and pull up on the cargo box release lever.
8. Lift the front of the cargo box to dump the cargo.
9. Lower the cargo box and push down securely to latch.
10. Close the tailgate and secure both tailgate latches.

WARNING! Operating the vehicle while the cargo box is raised could result in severe injury. The box could close unexpectedly and cause injury to the driver or passenger. The rear tires will also catch the rear of a raised box, damaging the vehicle and creating hazardous driving conditions. Never operate this vehicle with the cargo box in the raised position.

Towing Loads

Towing improperly can alter vehicle handling and may cause loss of control or brake instability. Always follow these precautions when towing:

1. Never load more than 150 lbs. (68.1 kg) tongue weight on the towing bracket.
2. Do not operate the vehicle faster than 10 mph (16 km/h) when towing. See page 52. Towing a trailer increases braking distance.
3. Do not tow more than the recommended weight for the vehicle. See the towing capacity chart below and the specifications charts beginning on page 104.
4. Attach a trailer to the trailer hitch bracket only. Do not attach a trailer to any other location or you may lose control of the vehicle.
5. Never tow a trailer on a grade steeper than 15°.

Model	Total Towed Load Weight (Level Ground)	Total Towed Load Weight (15° grade)	Total Hitch Vertical Weight	Maximum Towing Speed
<i>RANGER 4X4</i>	1250 lbs. (567 kg)	850 lbs. (386 kg)	150 lbs. (68.1 kg)	10 mph (16 kph)
<i>RANGER CREW</i>	1250 lbs. (567 kg)	850 lbs. (386 kg)	150 lbs. (68.1 kg)	10 mph (16 kph)

Belt Life

To extend belt life, use the lowest gear possible when hauling or towing heavy cargo.

OPERATION

Differential Operation Modes

The 4X4 rear axle is equipped with a lockable differential that allows the operator to choose between an open differential or a closed differential.

AWD

Press the top of the rocker switch to engage All Wheel Drive (AWD). When in AWD, the rear wheels rotate at the same speed. The front wheels also rotate at the same speed. See page 57 for AWD operating instructions.

2WD/Rear Differential Locked

Move the rocker switch to the center position to lock the differential and operate in two wheel drive (2WD). Locking the differential in slippery or low traction conditions helps improve traction. When the rear differential is locked, both rear wheels rotate at the same speed.

OFF/Differential Unlocked

Press the bottom of the switch to unlock the differential and allow the rear drive wheels to operate independently (1WD). When the rear differential is unlocked, the rear wheels can rotate at different speeds. Unlock the differential to make maneuvering easier and minimize damage to turf.

NOTICE: Damage to the differential can occur if it is engaged while the vehicle is traveling at high speeds or while the rear wheels are spinning. Slow the vehicle to nearly stopped before engaging the differential.

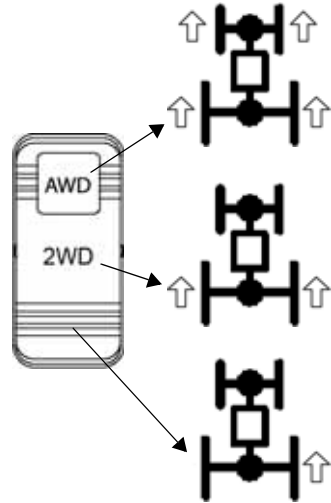

All Wheel Drive (AWD)

The illuminated amber AWD switch indicates that the vehicle is in AWD.

When the AWD switch is on, the front gearcase will automatically engage any time the rear wheels lose traction. When the rear wheels regain traction, the front gearcase will automatically disengage.

There is no limit to the length of time the vehicle may remain in AWD.

Initially, the vehicle's electronic system will not enable the AWD until the engine RPM is below 3100. Once enabled, the AWD remains enabled until the AWD switch is turned off. If the switch is turned off while the front gearcase is moving, it will not disengage until the rear wheels regain traction.

Engage the AWD before getting into conditions where front wheel drive may be needed. If the rear wheels are spinning, release the throttle before switching to AWD.

NOTICE: Switching to AWD while the rear wheels are spinning may cause severe drive shaft and clutch damage. Always switch to AWD while the rear wheels have traction or are at rest.

Disengaging AWD

Under certain conditions, it may be possible for the front gearcase to remain locked unnecessarily. This condition causes increased steering effort and some vehicle speed restriction. If the front gearcase remains locked after following these instructions, return the vehicle to your dealer for service.

1. Stop the vehicle.
2. Operate in reverse for at least 10 feet.
3. Stop completely.
4. Shift into low gear and drive forward.

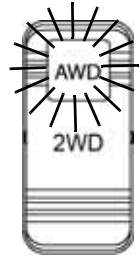

EMISSION CONTROL SYSTEMS

Noise Emission Control System

Do not modify the engine, intake or exhaust components, as doing so may affect compliance with U.S.A. EPA noise control requirements (40 CFR 205) and local noise level requirements.

Operation on Public Lands in the U.S.A.

Your POLARIS vehicle has a spark arrestor that was tested and qualified to be in accordance with the USFS standard 5100-1c. Federal law requires that this spark arrestor be installed and functional when the vehicle is operated on public lands.

Operation of off-road vehicles on public lands in the U.S.A. is regulated by 43 CFR 420. Violations are subject to monetary penalties. Federal regulations can be viewed online at www.gpoaccess.gov/ecfr/.

Crankcase Emission Control System

This engine is equipped with a closed crankcase system. Blow-by gases are forced back to the combustion chamber by the intake system. All exhaust gases exit through the exhaust system.

Exhaust Emission Control System

Exhaust emissions are controlled by engine design. An electronic fuel injection (EFI) system controls fuel delivery. The engine and EFI components are set at the factory for optimal performance and are not adjustable.

The emissions label is located on the frame under the seat.

Electromagnetic Interference

This spark ignition system complies with Canadian ICES-002.

This vehicle complies with the EMC requirements of European directives 97/24/EC and 2004/108/EC.

Non-ionizing Radiation: This vehicle emits some electromagnetic energy. People with active or non-active implantable medical devices (such as heart monitoring or controlling devices) should review the limitations of their device and the applicable electromagnetic standards and directives that apply to this vehicle.

Periodic Maintenance Chart

Careful periodic maintenance will help keep your vehicle in the safest, most reliable condition. Inspection, adjustment and lubrication of important components are explained in the periodic maintenance chart.

Inspect, clean, lubricate, adjust and replace parts as necessary. When inspection reveals the need for replacement parts, use genuine POLARIS parts available from your POLARIS dealer.

Record maintenance and service in the Maintenance Log beginning on page 119.

Tip: Service and adjustments are important for proper vehicle operation. If you're not familiar with safe service and adjustment procedures, have a qualified dealer perform these operations.

Maintenance intervals in the following chart are based upon average riding conditions and an average vehicle speed of approximately ten (10) miles per hour. Vehicles subjected to severe use must be inspected and serviced more frequently.

Severe Use Definition

- Frequent immersion in mud, water or sand
- Racing or race-style high RPM use
- Prolonged low speed, heavy load operation
- Extended idle
- Short trip cold weather operation

Pay special attention to the oil level. A rise in oil level during cold weather can indicate contaminants collecting in the oil sump or crankcase. Change oil immediately if the oil level begins to rise. Monitor the oil level, and if it continues to rise, discontinue use and determine the cause or see your dealer.

MAINTENANCE

Periodic Maintenance Chart

Maintenance Chart Key

► Perform these operations more often for vehicles subjected to severe use.

E Emission-related service (Failure to conduct this maintenance will not void the emissions warranty but may affect emissions.)

n Have an authorized POLARIS dealer perform these services.

WARNING! Improperly performing the procedures marked with a **n** could result in component failure and lead to serious injury or death. Have an authorized POLARIS dealer perform these services.

Perform all services at whichever maintenance interval is reached first.

Item		Maintenance Interval (whichever comes first)			Remarks
		Hours	Calendar	Miles (Km)	
n	Steering	-	Pre-Ride	-	Make adjustments as needed. See Pre-Ride Checklist on page 41.
►	Front suspension	-	Pre-Ride	-	
►	Rear suspension	-	Pre-Ride	-	
	Tires	-	Pre-Ride	-	
►	Brake fluid level	-	Pre-Ride	-	
►	Brake pedal travel				
	Brake system	-	Pre-Ride	-	
	Wheels/fasteners	-	Pre-Ride	-	
	Frame fasteners	-	Pre-Ride	-	
►	Engine oil level	-	Pre-Ride	-	
► E	Air filter, pre-filter	-	Daily	-	
► E	Air box sediment tube	-	Daily	-	Drain deposits when visible
	Coolant (if applicable)	-	Daily	-	Check level daily, change coolant every 2 years
	Headlamp/tail lamp	-	Daily	-	Check operation; apply dielectric grease if replacing
► E	Air filter, main element	-	Weekly	-	Inspect; replace as needed

► Perform these procedures more often for vehicles subjected to severe use.

E Emission-Related Service.

n Have an authorized POLARIS dealer perform these services.

MAINTENANCE

Periodic Maintenance Chart

Item		Maintenance Interval (whichever comes first)			Remarks
		Hours	Calendar	Miles (Km)	
▶ n	Brake pad wear	10 H	Monthly	-	Inspect periodically
	Battery	20 H	Monthly	-	Check terminals; clean; test
▶	Front Gearcase Oil (if equipped)	25 H	Monthly	-	Inspect level; change yearly
▶	Middle Gearcase Oil (if equipped)	25 H	Monthly	-	Inspect level; change yearly
▶	Rear gearcase oil (if equipped)	25 H	Monthly	-	Inspect level; change yearly
▶	Transmission oil	25 H	Monthly	-	Inspect level; change yearly
▶ E	Engine breather filter (if equipped)	25 H	Monthly	-	Inspect; replace if necessary
▶	Engine oil change (break-in)	25 H	1 M	-	Perform a break-in oil change at one month
▶	General lubrication	50 H	3 M	-	Lubricate all fittings, pivots, cables, etc.
	Shift Linkage	50 H	6 M	-	Inspect, lubricate, adjust
n	Steering	50H	6 M	-	Lubricate
▶	Front Suspension	50 H	6 M	-	Lubricate
▶	Rear Suspension	50 H	6 M	-	Lubricate
nE	Throttle cable	50 H	6 M	-	Inspect; adjust; lubricate; replace if necessary
E	Throttle body air intake ducts/flange	50 H	6 M	-	Inspect duct for proper sealing/air leaks
	Drive belt	50 H	6 M	-	Inspect; adjust; replace as needed
	Cooling system (if applicable)	50 H	6 M	-	Inspect coolant strength seasonally; pressure test system yearly
▶	Engine oil change	100 H	6 M	-	Perform a break-in oil change at one month
▶	Oil filter change	100 H	6 M	-	Replace with oil change

▶ Perform these procedures more often for vehicles subjected to severe use.

E Emission-Related Service.

n Have an authorized POLARIS dealer perform these services.

MAINTENANCE

Periodic Maintenance Chart

Item		Maintenance Interval (whichever comes first)			Remarks
		Hours	Calendar	Miles (Km)	
n	E Fuel system	100 H	12 M	-	Check for leaks at tank cap, lines, fuel valve, pump, throttle body; replace lines every 2 years
▶	Radiator (in applicable)	100 H	12 M	-	Inspect; clean external surfaces
▶	Cooling Hoses	100 H	12 M	-	Inspect for leaks
▶	Engine mounts	100 H	12 M	-	Inspect
	Exhaust muffler/pipe	100 H	12 M	-	Inspect
▶	E Spark plug	100 H	12 M	-	Inspect; replace as needed
n	Ignition timing	100 H	12 M	-	Inspect
▶	Wiring	100 H	12 M	-	Inspect for wear, routing, security; apply dielectric grease to connectors subjected to water, mud, etc.
n	Clutches (drive and driven)	100 H	12 M	-	Inspect; clean; replace worn parts
n	Front wheel bearings	100 H	12 M	-	Inspect; replace as needed
n	Brake fluid	200 H	24 M	-	Change every two years
	Spark arrestor	300 H	36 M	-	Clean out
	Idle speed	-			Adjust as needed
n	Toe adjustment	-			Inspect periodically; adjust when parts are replaced
n	▶ Auxiliary brake (if equipped)	-			Inspect daily; adjust as needed
	Headlight aim	-			Adjust as needed

▶ Perform these procedures more often for vehicles subjected to severe use.

E Emission-Related Service.

n Have an authorized POLARIS dealer perform these services.

MAINTENANCE

Lubrication Recommendations

Check and lubricate all components at the intervals outlined in the Periodic Maintenance Chart beginning on page 59, or more often under severe use, such as wet or dusty conditions. Items not listed in the chart should be lubricated at the general lubrication interval.

Item	Lube	Method
Engine Oil	POLARIS PS-4 <i>PLUS Performance</i> Synthetic 2W-50 4-cycle Oil	See page 65.
Brake Fluid	DOT 4	See page 86.
Main Gearcase Oil (Transmission)	Premium AGL Synthetic Gearcase Lube	See page 69.
Front Gearcase Oil	Demand Drive Plus Fluid	See page 70.
Front Prop Shaft Yoke	POLARIS Premium U-Joint Lube	Locate fittings and grease (3 pumps maximum).

MAINTENANCE

Engine Oil

Always check and change the engine oil at the intervals outlined in the Periodic Maintenance Chart beginning on page 59. Always change the oil filter whenever changing oil.

WARNING! Vehicle operation with insufficient, deteriorated, or contaminated engine oil will cause accelerated wear and may result in engine seizure, accident, and injury. Always perform the maintenance procedures as outlined in the Periodic Maintenance Chart.

Oil Recommendations

POLARIS recommends the use of POLARIS PS-4 *PLUS Performance* Synthetic 2W-50 4-cycle oil or a similar oil. See page 106 for the part numbers of POLARIS products.

NOTICE: Mixing brands or using a non-recommended oil may cause serious engine damage. Always use the recommended oil. Never substitute or mix oil brands.

Engine Oil

Always check and change the oil at the intervals outlined in the Periodic Maintenance Chart beginning on page 59. See page 64 for oil recommendations.

Oil Check

The oil tank is located under the seat.

1. Position the vehicle on a level surface. Place the transmission in PARK.
2. Start the engine and allow it to idle for 20-30 seconds. Stop the engine.
3. Remove the seat. See page 29.
4. Remove the dipstick. Wipe it dry with a clean cloth.
5. Reinstall the dipstick. Screw it in completely.
6. Remove the dipstick. Make sure that the oil level is in the safe range. Add oil if necessary. Do not overfill.

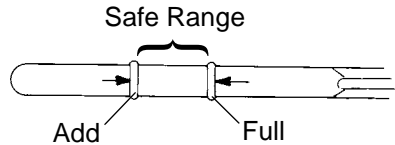
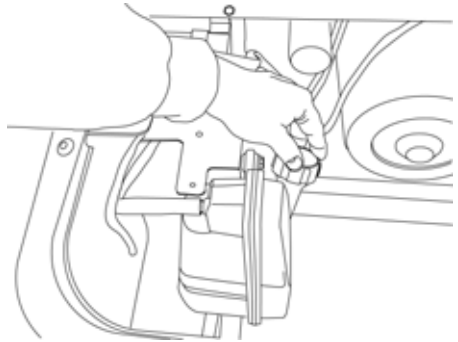

Tip: A rising oil level between checks in cool weather driving can indicate moisture collecting in the oil reservoir. If the oil level is above the full mark, change the oil.

MAINTENANCE

Engine Oil

Oil and Filter Change

Always change the oil and filter at the intervals outlined in the Periodic Maintenance Chart beginning on page 59. Always change the oil filter whenever changing oil.

1. Position the vehicle on a level surface.
2. Place the transmission in PARK.
3. Start the engine. Allow it to idle for two to three minutes. Stop the engine.
4. Clean the area around the drain plug.
5. Place a drain pan beneath oil tank.

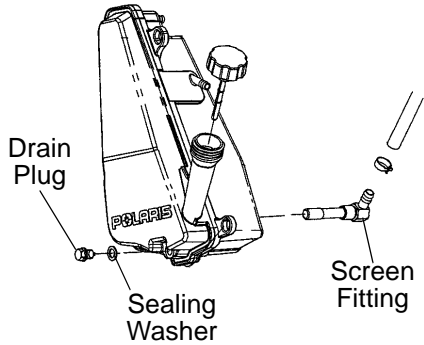

CAUTION! Hot oil can cause burns to skin. Do not allow hot oil to contact skin.

6. Remove the drain plug. Allow the oil to drain completely.
7. Install a new sealing washer on the drain plug. The sealing surfaces on drain plug and oil tank should be clean and free of burrs, nicks or scratches.
8. Reinstall the drain plug. Torque to 14 ft. lbs. (19 Nm).
9. Disconnect the lower oil delivery hose and remove the screen fitting from the oil tank. Clean the fitting.

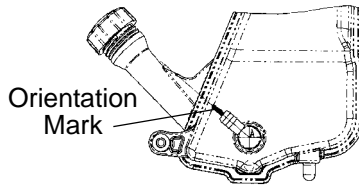

- Tip:** The fitting threads must be sealed with LOCTITE PST 505 or PTFE seal tape.
10. Reinstall the screen fitting and rotate the fitting clockwise a minimum of 2 1/2 turns into the tank threads. Continue to rotate the fitting until the nipple of the fitting aligns with the mark on the tank.
- Tip:** Do not over-tighten. Maximum torque for the screen fitting is 25 ft. lbs. (34 Nm).

Engine Oil Oil and Filter Change

11. Reattach the oil line.
 12. Place shop towels beneath the oil filter. Using an oil filter wrench, turn the filter counterclockwise to remove it.
 13. Using a clean dry cloth, clean the filter sealing surface on the crankcase.
 14. Lubricate the gasket on the new filter with a film of new engine oil. Make sure the gasket is in good condition. Make sure the gasket from the old filter is not still on the engine.
 15. Install the new filter and turn by hand until the filter gasket contacts the sealing surface, then turn an additional 1/2 turn.
 16. Approximately one cup of engine oil will remain in the crankcase. To drain, remove the drain plug on the lower right side of the crankcase.
- Tip:** The sealing surfaces on the drain plug and crankcase should be clean and free of burrs, nicks or scratches.
17. Reinstall the drain plug. Torque to 14 ft. lbs. (19 Nm).
 18. Remove the dipstick and fill the tank with two quarts (1.9 l) of the recommended oil.
 19. **Prime the oil pump using the procedure on page 68.** Then stop the engine and inspect for leaks.
 20. Check the oil level on the dipstick. Add oil as necessary to bring the level to the upper mark on the dipstick.
 21. Dispose of used filter and oil properly.



MAINTENANCE

Engine Oil

Oil and Filter Change

Oil Pump Priming

This priming procedure must be performed whenever the oil hose connection between the oil tank and pump inlet has been disconnected.

1. Clamp or pinch off the vent line approximately 2" (5 cm) from the oil tank, between the end of the oil tank vent fitting and the vent line's pressure relief slit.
2. Start the engine. Allow it to idle for 10-20 seconds.
3. Remove the vent line clamp. If the line is bled properly, you should hear a rush of air, indicating that the line is properly primed and ready for operation.

Tip: If you do not hear air, the line has not bled. Repeat the priming procedure.

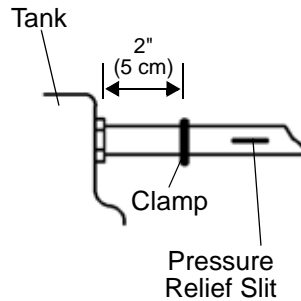

Gearcases

Gearcase Specification Chart

Gearcase	Lubricant	Capacity	Fill Plug Torque	Drain Plug Torque
Main Gearcase (Transmission)	Premium AGL Synthetic Gearcase Lube	34 oz. (1000 ml)	12 ft. lbs. (16.3 Nm)	12 ft. lbs. (16.3 Nm)
Front Gearcase	Demand Drive Plus Fluid	9.3 oz. (275 ml)	8-10 ft. lbs. (11-13.6 Nm)	11 ft. lbs. (15 Nm)

Gearcases

Transmission (Main Gearcase)

Always check and change the transmission oil at the intervals outlined in the Periodic Maintenance Chart beginning on page 59. Maintain the oil level even with the bottom of the fill plug hole threads.

Refer to the Gearcase Specifications Chart for recommended lubricants, capacities and torque specifications. See page 106 for the part numbers of POLARIS products.

Oil Check

The fill plug is located on the side of the gearcase.

1. Position the vehicle on a level surface.
2. Remove the fill plug.
3. Check the oil level. Add the recommended oil as needed.
4. Reinstall the fill plug. Torque to specification.

Oil Change

The drain plug is located near the bottom of the gearcase.

1. Remove the fill plug.
2. Place a drain pan under the gearcase.
3. Remove the drain plug. Allow the oil to drain completely.
4. Clean and reinstall the drain plug. Torque to specification.
5. Add the recommended oil.
6. Reinstall the fill plug. Torque to specification.
7. Check for leaks. Dispose of used oil properly.

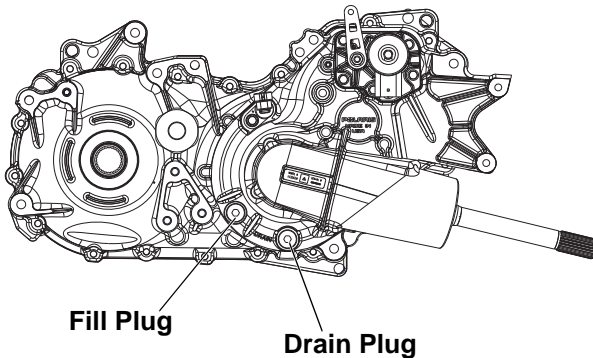

MAINTENANCE

Gearcases

Front Gearcase

Always check and change the front gearcase oil at the intervals outlined in the Periodic Maintenance Chart beginning on page 59. Maintain the oil level even with the bottom thread of the fill plug hole.

Refer to the Gearcase Specifications Chart on page 68 for recommended lubricants, capacities and torque specifications. See page 106 for the part numbers of POLARIS products.

Oil Check

The front gearcase fill plug is located on the right side of the front gearcase.

1. Position the vehicle on a level surface.
2. Remove the fill plug. Check the oil level.
3. Add the recommended oil as needed.
4. Reinstall the fill plug. Torque to specification.

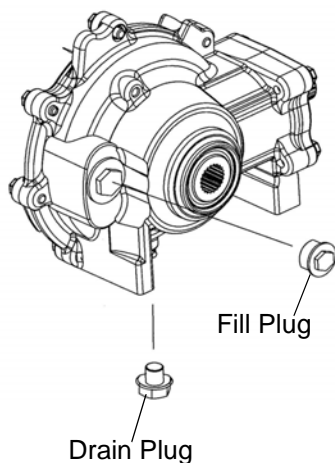

Gearcases

Front Gearcase

Oil Change

1. Support the vehicle securely with a jackstand.
2. Remove the front tire on the driver's side.
3. Remove the fill plug.
4. Place a drain pan under the drain plug on the bottom right-hand side.
5. Remove the drain plug. Drain the oil.
6. Clean the drain plug. Reinstall the drain plug. Torque to specification.
7. Add the recommended oil.
8. Reinstall the fill plug. Torque to specification.
9. Check for leaks.
10. Discard used oil properly.

MAINTENANCE

Spark Plugs

Spark Plug Recommendations

Refer to the specifications section beginning on page 104 for the recommended spark plug type for your vehicle. Always torque spark plugs to specification.

NOTICE: Using non-recommended spark plugs can result in serious engine damage. Always use POLARIS-recommended spark plugs.

Spark Plug Gap/Torque

Model	Electrode Gap	New Plug Torque	Used Plug Torque
4X4	.036" (.9 mm)	9-11 ft. lbs. (12-15 Nm)	9-11 ft. lbs. (12-15 Nm)
CREW	.036" (.9 mm)	9-11 ft. lbs. (12-15 Nm)	9-11 ft. lbs. (12-15 Nm)

Spark Plug Inspection

Spark plug condition is indicative of engine operation. The spark plug firing end condition should be read after the engine is warmed up and the vehicle is driven at higher speeds. Immediately check the spark plug for correct color. See page 72.

CAUTION! A hot exhaust system and engine can cause burns. Wear protective gloves when removing a spark plug for inspection.

1. Remove the seat to access the engine compartment.
2. Remove the spark plug cap. Using the spark plug wrench provided in the tool kit, remove the plug by rotating it counterclockwise.
3. Reverse the procedure for spark plug installation. Torque to specification.

Spark Plugs

Spark Plug Inspection

Normal Plug

The normal insulator tip is gray, tan or light brown. There will be few combustion deposits. The electrodes are not burned or eroded. This indicates the proper type and heat range for the engine and the service.

The tip should not be white. A white insulator tip indicates overheating, caused by use of an improper spark plug or incorrect throttle body adjustments.

Wet Fouled Plug

The wet fouled insulator tip is black. A damp oil film covers the firing end. There may be a carbon layer over the entire nose. Generally, the electrodes are not worn. General causes of fouling are excessive oil, use of non-recommended injection oil or incorrect throttle body adjustments.

MAINTENANCE

Cooling System

The engine coolant level is controlled or maintained by the recovery system. The recovery system components are the overflow bottle, radiator filler neck, radiator pressure cap and connecting hose.

As coolant operating temperature increases, the expanding (heated) excess coolant is forced out of the radiator, past the pressure cap, and into the overflow bottle. As engine coolant temperature decreases, the contracting (cooled) coolant is drawn back up from the tank, past the pressure cap, and into the radiator.

Some coolant level drop on new vehicles is normal as the system is purging itself of trapped air. Observe coolant levels and maintain as recommended by adding coolant to the overflow bottle.

Adding or Changing Coolant

To ensure that the coolant maintains its ability to protect the engine, we recommend that the system be completely drained every two years and a fresh mixture of antifreeze and water added. POLARIS recommends the use of POLARIS Premium 60/40 anti-freeze/coolant or a 50/50 mixture of high quality aluminum compatible anti-freeze/coolant and distilled water. POLARIS Premium 60/40 is already premixed and ready to use. Do not dilute with water. See page 106 for the part numbers of POLARIS products.

Always follow the manufacturer's mixing recommendations for the freeze protection required in your area.

Any time the cooling system has been drained for maintenance or repair, replace the coolant. If the recovery bottle has run dry, the level in the radiator should be inspected. Add coolant as needed.

Cooling System Radiator and Cooling Fan

Always check and clean the screen and radiator fins at the intervals outlined in the Periodic Maintenance Chart beginning on page 59. Do not obstruct or deflect air flow through the radiator by installing unauthorized accessories in front of the radiator or behind the cooling fan. Interference with the radiator air flow can lead to overheating and consequent engine damage.

NOTICE: Washing the vehicle with a high-pressure hose could damage the radiator fins and impair the radiator's effectiveness. Using a high-pressure system is not recommended.

Overflow Bottle Coolant Level

Always check and change the coolant at the intervals outlined in the Periodic Maintenance Chart beginning on page 59. Maintain the coolant level between the minimum and maximum marks on the bottle (when the fluid is cool).

1. Position the vehicle on a level surface.
2. Lift the hood. View the coolant level in the overflow bottle.
3. If the coolant level is below the safe operating range, lift the hood and locate the overflow bottle lid. Remove the cap and use a funnel to add coolant through the filler opening. Reinstall the cap.

Tip: If coolant must be added often, or if the overflow bottle runs completely dry, there may be a leak in the system. Have the cooling system inspected by your POLARIS dealer.

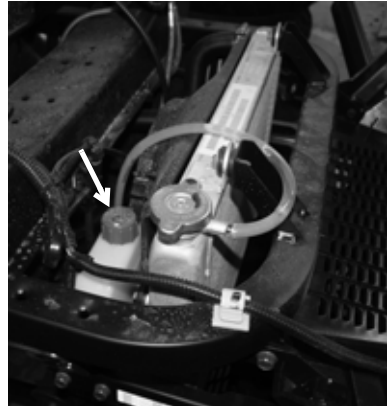

MAINTENANCE

Cooling System

Radiator Coolant Level

Always check and clean the screen and radiator fins at the intervals outlined in the Periodic Maintenance Chart beginning on page 59. Do not obstruct or deflect air flow through the radiator by installing unauthorized accessories in front of the radiator or behind the cooling fan. Interference with the radiator air flow can lead to overheating and consequentially, engine damage.

1. Lift the hood.

CAUTION! Escaping steam can cause burns. Never remove the pressure cap while the engine is warm or hot. Always allow the engine to cool before removing the pressure cap.

2. Slowly remove the radiator cap.
3. View the coolant level through the opening.
4. Use a funnel and slowly add coolant as needed.

Tip: This procedure is required only if the cooling system has been drained for maintenance and/or repair. But if the overflow bottle has run dry, the level in the radiator should also be inspected.

5. Reinstall the pressure cap. Use of a non-standard pressure cap will not allow the recovery system to function properly. See your dealer for the correct replacement part.



MAINTENANCE

POLARIS Variable Transmission (PVT) System

⚠ WARNING

Failure to comply with the instructions in this warning can result in severe injury or death.

Do not modify any component of the PVT system. Doing so may reduce its strength so that a failure may occur at a high speed. The PVT system has been precision balanced. Any modification will cause the system to be out of balance, creating vibration and additional loads on components.

The PVT system rotates at high speeds, creating large amounts of force on clutch components. Extensive engineering and testing has been conducted to ensure the safety of this product. However, as the owner, you have the following responsibilities to make sure this system remains safe:

- Always follow all recommended maintenance procedures. See your dealer as outlined in the owner's manual.
- This PVT system is intended for use on POLARIS products only. Do not install it in any other product.
- Always make sure the PVT housing is securely in place during operation.

When To Use Low Range vs. High Range

Belt slip is responsible for creating excessive heat that destroys belts, wears clutch components and causes outer clutch covers to fail. Switch to low range while operating at slower speeds to extend the life of the PVT components (belt, cover, etc.).

Condition	Range to Use
Operating at speeds less than 7 MPH (11 km/h)	Low
Towing heavy loads	Low
Operating in rough terrain (swamps, mountains, etc.)	Low
Operating at speeds greater than 7 MPH (11 km/h)	High

MAINTENANCE

PVT System

PVT Drying

There may be some instances when water is ingested into the PVT system. Use the following instructions to dry it out before operating.

1. Position the vehicle on a level surface.
2. Remove the drain plug. Allow the water to drain completely. Reinstall the drain plug.
3. Place the transmission in PARK.
4. Start the engine.
5. Apply varying throttle for 10-15 seconds to expel the moisture and air-dry the belt and clutches. Do not hold the throttle wide open for more than 10 seconds.
6. Allow the engine RPM to settle to idle speed. Apply the brakes. Shift the transmission to the lowest available range.
7. Test for belt slippage. If the belt slips, repeat the process.
8. Take the vehicle to your dealer for service as soon as possible.

Vehicle Immersion

NOTICE: If your vehicle becomes immersed, major engine damage can result if the machine is not thoroughly inspected. Take the vehicle to your dealer before starting the engine.

If it's impossible to take your *RANGER* to a dealer before starting it, follow the steps outlined below.

1. Move the vehicle to dry land or at the very least, to water below the footrests.
2. Dry any water present in the air box. Filter replacement is required if water is present.
3. Thoroughly dry the air pre-cleaner located under the hood.
4. Remove the spark plugs. Turn the engine over several times using the electric start.
5. Dry the spark plugs and reinstall, or replace with new plugs.
6. Attempt to start the engine. If necessary, repeat the drying procedure.
7. Take the vehicle to your dealer for service as soon as possible, whether you succeed in starting it or not.
8. If water has been ingested into the PVT follow the procedure on page 78 for drying.

MAINTENANCE

Filter Systems

Air Filter

Always change the air filter at the intervals outlined in the Periodic Maintenance Chart beginning on page 59. Service the air filter more frequently if the vehicle is operated in wet conditions or at high throttle openings for extended periods.

1. Lift the cargo box to access the air box.
2. Remove the air box cover and inspect the gasket. It should adhere tightly to the cover and seal all the way around.

Tip: Grasp the filter end to prevent damage to the filter paper.

3. Remove the air filter.
4. Do not attempt to clean the main element.
Install a new air filter.

Tip: Apply a small amount of general purpose grease to the sealing edges of the filter before installing.

5. Inspect the air box for oil or water deposits. If present, drain them into a suitable container.

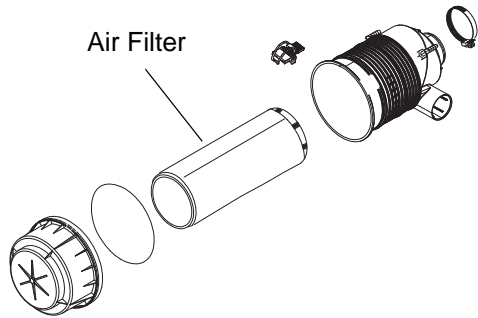

Filter Systems

Breather Filter and Hoses

1. Lift the cargo box and locate the air box.
2. Follow the right-hand breather line out the side of the air box and locate the filter.
3. Remove and inspect the filter for debris. Blow gently through the filter in the direction of the arrow to check for clogging. Replace as needed.
4. Check hoses for cracks, deterioration, abrasion, or leaks. Replace as needed.
5. Reinstall the filter with the arrow pointing toward the engine. Secure the clamps.

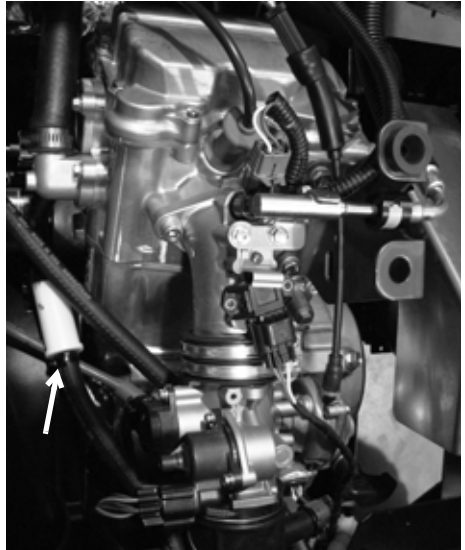

NOTICE: Operation of the vehicle without a breather filter can cause engine damage. Always reinstall the breather filter after removing it for service.

MAINTENANCE

Spark Arrestor

WARNING

Failure to heed the following warnings while servicing the spark arrestor could result in serious injury or death.

Do not perform service on the spark arrestor while the system is hot. Exhaust system temperatures can reach 1000° F. Allow components to cool sufficiently before proceeding.

Remove any combustible materials from the area.

Wear eye protection and gloves.

Do not stand behind or in front of the vehicle while purging.

Never run the engine in an enclosed area. Exhaust contains poisonous carbon monoxide gas that can cause loss of consciousness or death in a very short time.

Never go under the vehicle while it's inclined.

Spark Arrestor

Use the following procedure to periodically purge accumulated carbon from the exhaust pipe.

1. Remove the arrestor clean-out plug located on the bottom of the muffler.
2. Place the transmission in PARK.
3. Start the engine.
4. Purge accumulated carbon from the system by momentarily revving the engine several times.
5. If carbon is expelled, cover or plug the exhaust outlet and rap on the pipe around the clean-out plug while revving the engine several more times.
6. If particles are still suspected to be in the muffler, elevate the rear of the vehicle one foot higher than the front. Block the wheels.
7. Repeat steps 4 and 5 until no more particles are expelled when the engine is revved.
8. Stop the engine. Allow the arrestor to cool.
9. Reinstall the arrestor plug and remove the outlet cover or plug.

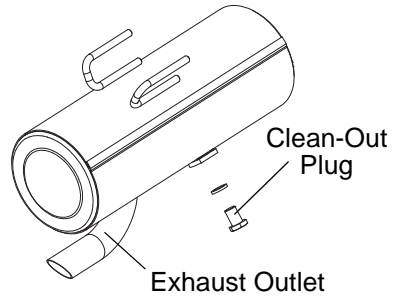

MAINTENANCE

Throttle System

⚠ WARNING

Failure to check or maintain proper operation of the throttle system can result in an accident and lead to serious injury or death if the throttle pedal sticks during operation.

Always check the pedal for free movement and return before starting the engine and occasionally during operation. Never start or operate this vehicle if it has a sticking or improperly operating throttle pedal. Immediately contact your dealer for service if throttle problems arise.

Throttle Freeplay

If the throttle pedal has excessive play due to cable stretch or mis-adjustment, it will cause a delay in throttle response, especially at low engine speed. The throttle may also not open fully. If the throttle pedal has no freeplay, the throttle may be hard to control, and the idle speed may be erratic.

Check the throttle pedal freeplay at the intervals outlined in the Periodic Maintenance Chart beginning on page 59. Adjust the freeplay if necessary.

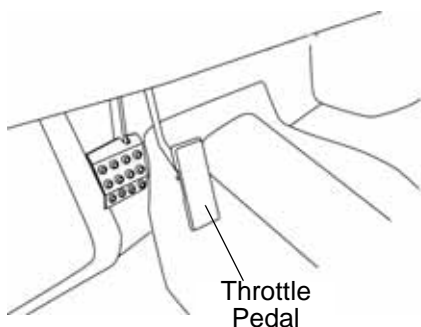

Throttle Freeplay Inspection

1. Place the transmission in PARK.
2. Start the engine. Allow it to warm up thoroughly.
3. Measure the distance the throttle pedal moves before the engine begins to pick up speed. Freeplay should be 1/16 to 1/8 inches (1.6-3.2 mm).

Throttle System

Throttle Body/Idle RPM

Idle RPM is preset by the manufacturer. If the engine idle speed is not satisfactory, please see your POLARIS dealer for adjustment.

Throttle Freeplay Adjustment

1. Remove the seat.
2. Locate the throttle cable adjuster.
3. Squeeze the end of the rubber boot and slide it far enough to expose the end of the inline cable adjuster.
4. Loosen the adjuster lock nut.
5. Rotate the boot to turn the adjuster until $1/16''$ to $1/8''$ (1.5-3 mm) of freeplay is achieved at the throttle pedal. See page 84.

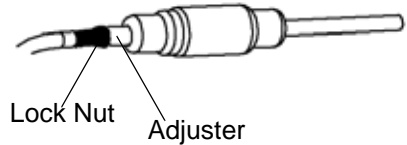
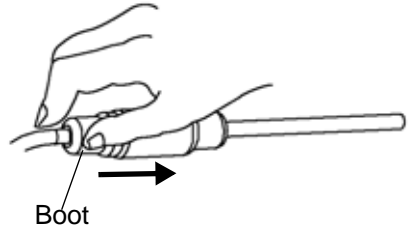

Tip: While adjusting, lightly flip the throttle pedal up and down.

6. Tighten the lock nut.
7. Squeeze the end of the rubber boot and slide it over the cable adjuster to its original position.

Cylinder Head/Cylinder Base Fastener Torque

Have your dealer check the cylinder head and cylinder base fasteners for proper torque at the first service or after 25 hours.

MAINTENANCE

Brakes

The front and rear brakes are hydraulic disc type brakes. Press down on the brake pedal to engage the brakes. See page 25.

Brake Fluid

Inspect the brake system routinely. Inspect the level of the brake fluid before each operation.

WARNING! After opening a bottle of brake fluid, always discard any unused portion. Never store or use a partial bottle. Brake fluid is hygroscopic, meaning it rapidly absorbs moisture from the air. The moisture causes the boiling temperature of the brake fluid to drop, which can lead to early brake fade and the possibility of accident or severe injury.

Change the brake fluid every two years and any time the fluid becomes contaminated, the fluid level is below the minimum, or if the type and brand of the fluid in the reservoir are unknown. See page 63 for fluid recommendations.

1. Position the vehicle on a level surface.
2. View the brake fluid level at the reservoir in the driver's side wheel well. The level should be between the upper (MAX) and lower (MIN) level lines.
3. If the fluid level is lower than the upper level line, add brake fluid to the upper (MAX) line.
4. Apply the brake forcefully for a few seconds and check for fluid leakage around the fittings.

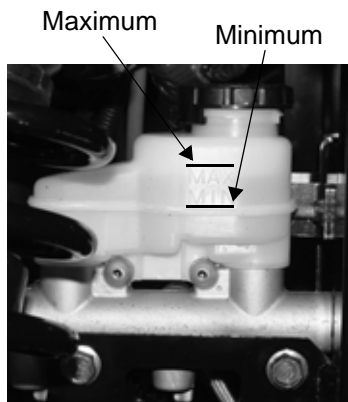

Brakes

Brake Inspection

1. Check the brake system for fluid leaks.
2. Check the brake pedal for excessive travel or a spongy feel.
3. Check the friction pads for wear, damage and looseness.
4. Inspect the brake disc spline and pad wear surface for excessive wear.
5. Change pads when worn to 3/64" (1 mm).

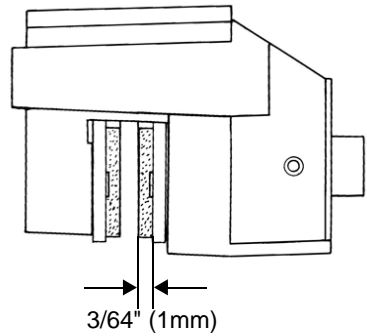

Steering Wheel Inspection

Check the steering wheel for specified freeplay and smooth operation at the intervals outlined in the Periodic Maintenance Chart beginning on page 59.

1. Position the vehicle on a level surface.
2. Lightly turn the steering wheel left and right.
3. There should be 0.8"-1.0" (20-25 mm) of freeplay.
4. If there is excessive freeplay or strange noises, or the steering feels rough or "catchy," have the steering system inspected by an authorized POLARIS dealer.

Spring Adjustment

Adjust the front and rear shock absorber springs by rotating the adjustment cam either clockwise or counterclockwise to increase or decrease spring tension.

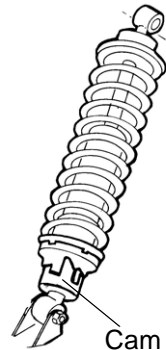

MAINTENANCE

Tires

⚠ WARNING

Operating your vehicle with worn tires, improperly inflated tires, non-standard tires or improperly installed tires will affect vehicle handling and could cause an accident resulting in serious injury or death. Always follow all tire maintenance procedures as outlined in this manual and on the labels on the vehicle. Always use original equipment size and type when replacing tires.

Tire Tread Depth

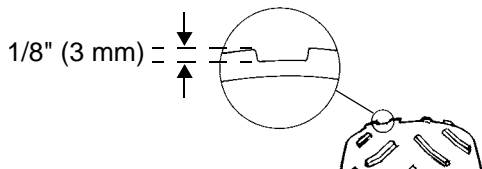

Always replace tires when tread depth is worn to 1/8" (3 mm) or less.



Axle and Wheel Nut Torque Specifications

Inspect the following items occasionally for tightness, and if they've been loosened for maintenance service.

Do not lubricate the stud or the lug nut.

Nut Type	Location	Nut Torque
Lug Nut (Aluminum Wheels) 	Front and Rear	30 ft. lbs. (41 Nm) PLUS 1/4 TURN
Nut and Washer (Steel Wheels) 	Front and Rear	35 ft. lbs. (47 Nm)
Spindle Nut	Front	70 ft. lbs. (95 Nm)
Hub Retaining Nuts	Center and Rear	110 ft. lbs. (150 Nm)

Tires

Wheel Removal

1. Apply the brakes.
2. Place the transmission in PARK.
3. Stop the engine.
4. Loosen the wheel nuts slightly.
5. Elevate the side of the vehicle by placing a suitable stand under the frame.
6. Remove the wheel nuts and washers. Remove the wheel.

Wheel Installation

1. Place the transmission in PARK.
2. Place the wheel in the correct position on the wheel hub. Be sure the valve stem is toward the outside and rotation arrows on the tire point toward forward rotation.

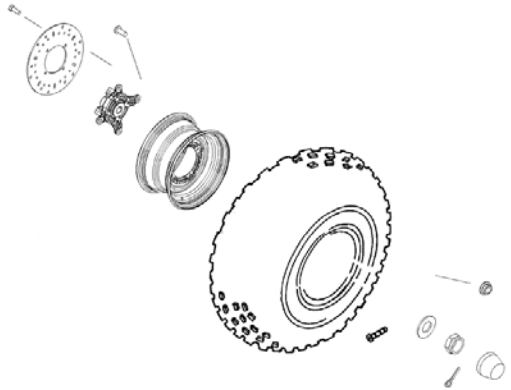

WARNING! Improperly installed wheels can adversely affect tire wear and vehicle handling, which can result in serious injury or death. Always ensure that all nuts are torqued to specification. Do not service axle nuts that have a cotter pin installed. See your POLARIS dealer.

3. Attach the wheel nuts and washers and finger tighten.
4. Carefully lower the vehicle to the ground.
5. Torque the wheel nuts to specification. See page 88.

MAINTENANCE

Lights

Poor lighting can result in reduced visibility when driving. Headlight and taillight lenses become dirty during normal operation. Clean lights frequently and replace burned out lamps promptly. Always make sure lights are adjusted properly for best visibility.

When servicing a halogen lamp, don't touch the lamp with bare fingers. Oil from your skin leaves a residue, causing a hot spot that will shorten the life of the lamp.

Headlight Lamp Replacement

1. Open the hood.

CAUTION! Hot components can cause burns to skin. Allow lamps to cool before servicing.

2. Unplug the headlamp from the wiring harness. Be sure to pull on the connector, not on the wiring.
3. Turn the lamp counter-clockwise to remove it.
4. Install the new lamp.

Tip: Make sure the tab on the lamp locates properly in the housing.

5. Reinstall the harness assembly into the headlight assembly.



Lights

Headlight Beam Adjustment

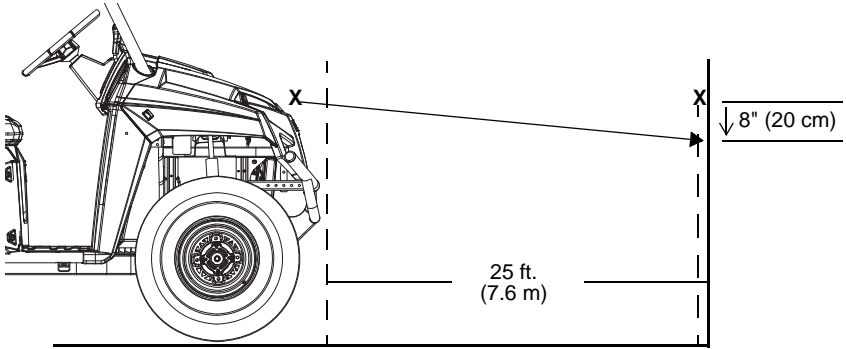

1. Place the vehicle on a level surface with the headlight approximately 25 ft. (7.6 m) from a wall.
2. Measure the distance from the floor to the center of the headlight and make a mark on the wall at the same height.
3. Apply the brakes. Start the engine. Turn on the headlights.
4. Observe the headlight aim. The most intense part of the headlight beam should be aimed 8" (20 cm) below the mark placed on the wall. Include the weight of a rider on the seat while performing this step.
5. If a headlight needs adjustment, locate the adjustment screw at the back of the headlight.
6. Loosen the screw, adjust the headlight, and tighten the screw.
7. Repeat steps 4-6 until the lamp is properly adjusted.

Brake Lights

When the brake pedal is depressed, the console brake light comes on. Check the brake light before each ride.

1. Turn the ignition switch to the ON position.
2. Depress the brake pedal. The brake light should come on after about 10mm (0.4 in.) of pedal travel. If the light doesn't come on, check the bulb.

MAINTENANCE

Battery

WARNING

Battery electrolyte is poisonous. It contains sulfuric acid. Serious burns can result from contact with skin, eyes or clothing.

Antidote:

External: Flush with water.

Internal: Drink large quantities of water or milk. Follow with milk of magnesia, beaten egg, or vegetable oil. Call physician immediately.

Eyes: Flush with water for 15 minutes and get prompt medical attention.

Batteries produce explosive gases. Keep sparks, flame, cigarettes, etc. away. Ventilate when charging or using in an enclosed space. Always shield eyes when working near batteries. KEEP OUT OF REACH OF CHILDREN.

Your vehicle may have either a sealed battery, which requires little maintenance, or a conventional battery. A sealed battery can be identified by its flat covers on the top of the battery. A conventional battery has six filler caps on the top of the battery.

Always keep battery terminals and connections free of corrosion. If cleaning is necessary, remove the corrosion with a stiff wire brush. Wash with a solution of one tablespoon baking soda and one cup water. Rinse well with tap water and dry off with clean shop towels. Coat the terminals with dielectric grease or petroleum jelly. Be careful not to allow cleaning solution or tap water into the battery.

Battery

Battery Removal

▲ WARNING

Improperly connecting or disconnecting battery cables can result in an explosion and cause serious injury or death. When removing the battery, always disconnect the negative (black) cable first. When reinstalling the battery, always connect the negative (black) cable last.

1. Remove the front seat.
2. On conventional batteries, remove the battery vent tube.
3. Disconnect the black (-) battery cable first. Disconnect the red (+) battery cable last.
4. Remove the battery hold-down strap.
5. Lift the battery out of the vehicle.
Be careful not to tip a conventional battery sideways, which could spill electrolyte.



NOTICE: If electrolyte spills, immediately wash it off with a solution of one tablespoon baking soda and one cup water to prevent damage to the vehicle.

MAINTENANCE

Battery

Battery Installation

Using a new battery that has not been fully charged can damage the battery and result in a shorter life. It can also hinder vehicle performance. Follow the battery charging instructions on page 95 before installing the battery.

1. Ensure that the battery is fully charged.
2. Place the fully charged battery in the battery holder.
3. With conventional batteries, install the battery vent tube (sealed batteries do not have a vent tube). The vent tube must be free of obstructions and securely installed. Route the tube away from the frame and vehicle body to prevent contact with electrolyte.

WARNING! Battery gases could accumulate in an improperly installed vent tube and cause an explosion, resulting in serious injury or death. Always ensure that the vent tube is free of obstructions and is securely installed as recommended.

4. Coat the terminals with dielectric grease or petroleum jelly.
5. Connect and tighten the red (+) cable first. Connect and tighten the black (-) cable last.
6. Verify that cables are properly routed. Cables should be safely tucked away at the front and rear of the battery.
7. Install the battery hold-down strap.

Battery

Battery Storage

Whenever the vehicle is not used for a period of three months or more, remove the battery from the vehicle, ensure that it's fully charged, and store it out of the sun in a cool, dry place. Check battery voltage each month during storage and recharge as needed to maintain a full charge. See page 95.

POLARIS recommends maintaining battery charge by using a POLARIS Battery Tender charger or by charging about once a month to make up for normal self-discharge. Battery Tender can be left connected during the storage period, and will automatically charge the battery if the voltage drops below a pre-determined point. See page 106 for the part numbers of POLARIS products.

Battery Fluid (Conventional Battery)

A poorly maintained battery will deteriorate rapidly. Check the battery fluid level often. Maintain the fluid level between the upper and lower level marks.

Add only distilled water. Tap water contains minerals that are harmful to a battery.

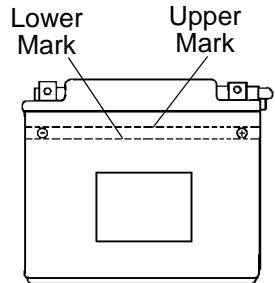

Battery Charging (Conventional Battery)

1. Remove the battery from the vehicle to prevent damage from leaking or spilled electrolyte during charging. See page 93.
2. Charge the battery with a charging output no larger than 1/10 of the battery's amp/hr rating. Charge as needed to raise the specific gravity to 1.270 or greater.
3. Reinstall the battery. See page 94. Make sure the positive terminal is toward the driver's side of the vehicle.

MAINTENANCE

Battery

Battery Charging (Sealed Battery)

The following battery charging instructions apply only to the installation of a sealed battery. Read all instructions before proceeding with the installation of this battery.

The sealed battery is already filled with electrolyte and has been sealed and *fully charged* at the factory. *Never* pry the sealing strip off or add any other fluid to this battery.

The single most important thing about maintaining a sealed battery is to keep it fully charged. Since the battery is sealed and the sealing strip cannot be removed, you must use a voltmeter or multimeter to measure DC voltage.

WARNING! An overheated battery may explode, causing severe injury or death. Always watch charging times carefully. Stop charging if the battery becomes very warm to the touch. Allow it to cool before resuming charging.

For a refresh charge, follow all instructions carefully.

1. Check the battery voltage with a voltmeter or multimeter. A fully charged battery will register 12.8 V or higher. If the voltage is less than 12.8 volts, recharge the battery at 1.2 amps or less until battery voltage is 12.8 or greater.
2. When using an automatic charger, refer to the charger manufacturer's instructions for recharging. When using a constant current charger, use the guidelines on the next page for recharging.

Always verify battery condition before and 1-2 hours after the end of charging.

State of Charge	Voltage	Action	Charge Time (Using constant current charger @ standard amps specified on top of battery)
100%	12.8-13.0 volts	None, check at 3 mos. from date of manufacture	None required
75%-100%	12.5-12.8 volts	May need slight charge, if no charge given, check in 3 months	3-6 hours
50%-75%	12.0-12.5 volts	Needs charge	5-11 hours
25%-50%	11.5-12.0 volts	Needs charge	At least 13 hours, verify state of charge
0%-25%	11.5 volts or less	Needs charge with desulfating charger	At least 20 hours

Fuses

Fuse	Feature Supported
10A	Accessories, 12V Power Receptacle
10A	Headlight
10A	Taillight
20A	Chassis

If the engine stops or will not start, or if you experience other electrical failures, a fuse may need replacement. Locate and correct any short circuits that may have caused the blown fuse, then replace the fuse. Spare fuses are provided in the fuse box.

If you suspect that a fuse or relay may not be working properly, please see your POLARIS dealer.

NEUTRAL RELAY	FAN RELAY	ACS RELAY	
	HEADLIGHT 10A	SPARE 20A	SPARE 10A
	TAILLIGHT 10A	ACCESSORY 10A	CHASSIS 20A

7176306

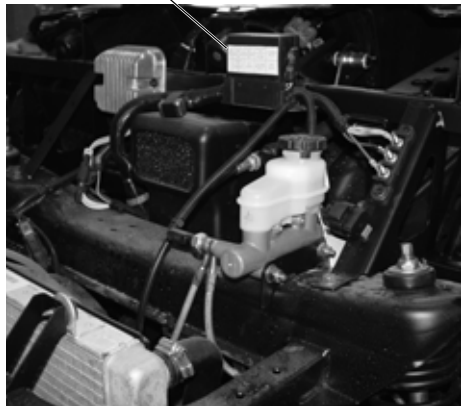

MAINTENANCE

Cleaning and Storage

Washing the Vehicle

Keeping your POLARIS vehicle clean will not only improve its appearance but it can also extend the life of various components.

NOTICE: High water pressure may damage components. POLARIS recommends washing the vehicle by hand or with a garden hose, using mild soap.

NOTICE: Certain products, including insect repellents and chemicals, will damage plastic surfaces. Do not allow these types of products to contact the vehicle.

The best and safest way to clean your POLARIS vehicle is with a garden hose and a pail of mild soap and water.

1. Use a professional-type washing cloth, cleaning the upper body first and the lower parts last.
2. Rinse with clean water frequently.
3. Dry surfaces with a chamois to prevent water spots.

Washing Tips

- Avoid the use of harsh cleaners, which can scratch the finish.
- Do not use a power washer to clean the vehicle.
- Do not use medium to heavy duty compounds on the finish.
- Always use clean cloths and pads for cleaning and polishing. Old or reused cloths and pads may contain dirt particles that will scratch the finish.

Cleaning and Storage

Washing the Vehicle

If a high pressure water system is used for cleaning (not recommended), exercise extreme caution. The water may damage components and could remove paint and labels. Avoid directing the water stream at the following items:

- Wheel bearings
- Radiator
- Transmission seals
- Brakes
- Cab and body panels
- Labels and decals
- Switches and controls
- Electrical components and wiring

If an informational or graphic label becomes illegible or comes off, contact your POLARIS dealer to purchase a replacement. Replacement *safety* labels are provided by POLARIS at no charge.

Grease all zerk fittings immediately after washing. Allow the engine to run for a while to evaporate any water that may have entered the engine or exhaust system.

Polishing the Vehicle

POLARIS recommends the use of common household aerosol furniture polish for polishing the finish on your POLARIS vehicle. Follow the instructions on the container.

Polishing Tips

- Avoid the use of automotive products, some of which can scratch the finish of your vehicle.
- Always use clean cloths and pads for cleaning and polishing. Old or reused cloths and pads may contain dirt particles that will scratch the finish.

MAINTENANCE

Cleaning and Storage

Chrome Wheel Care (if equipped)

Proper maintenance will protect chrome wheels from corrosion, preserve wheel life and ensure a “like new” appearance for many years. Chrome wheels exposed to road salt (or salt in the air in coastal areas) are more susceptible to corrosion if not properly cleaned. Clean chrome wheels more often if they're exposed to salt or other corrosive elements.

1. Wash chrome wheels frequently. Use a mild detergent. Never use abrasive cleaners on plated or painted surfaces.
2. Rinse well with clear water. Soap, detergents, salt, dirt, mud and other elements can cause corrosion.
3. Polish the clean chrome wheels periodically. Use an automotive grade chrome polish.
4. Routinely and liberally apply a weather resistant wax to each polished chrome wheel. Choose a product suitable for chrome finishes. Read and follow the product labels and instructions.

Removing Corrosion

If light rust is found on the chrome finish, use steel wool (#0000-OTT grade) to remove it. Gently rub the affected areas with the steel wool until the corrosion has been removed. Clean and polish the wheel as outlined above.

Cleaning and Storage

Storage Tips

NOTICE: Starting the engine during the storage period will disturb the protective film created by fogging and damage could occur. Never start the engine during the storage period.

Clean the Exterior

Make any necessary repairs and clean the vehicle as recommended. See page 98.

Stabilize the Fuel

1. Fill the fuel tank.
2. Add POLARIS Carbon Clean Fuel Treatment or POLARIS Fuel Stabilizer. Follow the instructions on the container for the recommended amount. Carbon Clean removes water from fuel systems, stabilizes fuel and removes carbon deposits from pistons, rings, valves and exhaust systems.
3. Allow the engine to run for 15-20 minutes to allow the stabilizer to disperse through the entire fuel delivery system.

Oil and Filter

Change the oil and filter. See page 66.

Air Filter / Air Box

1. Inspect and clean or replace the pre-cleaner and air filter. See page 80.
2. Clean the air box.
3. Drain the sediment tube.

Inspect and Lubricate

Inspect all cables and lubricate all areas of the vehicle as recommended in the Periodic Maintenance Chart beginning on page 59.

Battery Maintenance

See pages 95-96 for storage and charging procedures.

MAINTENANCE

Cleaning and Storage

Storage Tips

Fluid Levels

Inspect the fluid levels. Add or change fluids as recommended in the Periodic Maintenance Chart beginning on page 59.

- Front and rear gearcase fluid (if equipped)
- Transmission fluid
- Brake fluid (change every two years and any time the fluid looks dark or contaminated)
- Coolant (test strength/fill)

Fog the Engine

1. Treat the fuel system with POLARIS Carbon Clean. Follow the instructions on the container. Start the engine. Allow it to idle for several minutes so the Carbon Clean reaches the injectors. Stop the engine.
2. Remove the spark plugs and add 2-3 tablespoons of engine oil. To access the plug holes, use a section of clear 1/4" hose and a small plastic squeeze bottle filled with the pre-measured amount of oil. *Do this carefully!* If you miss the plug holes, oil will drain from the spark plug cavities into the hole at the front of the cylinder head, and appear to be an oil leak.
3. Reinstall the spark plugs. Torque to specification. See page 72.
4. Apply dielectric grease to the inside of each spark plug cap and reinstall the caps onto the plugs.
5. Turn the engine over several times. Oil will be forced in and around the piston rings and ring lands, coating the cylinder with a protective film of fresh oil.
6. If POLARIS fuel system additive is not used, fuel tank, fuel lines, and injectors should be completely drained of gasoline.

Storage Area/Covers

Be sure the storage area is well ventilated. Cover the vehicle with a genuine POLARIS cover. Do not use plastic or coated materials. They do not allow enough ventilation to prevent condensation, and may promote corrosion and oxidation.

Removal from Storage

1. Check the battery electrolyte level and charge the battery if necessary. Install it in the vehicle. Make sure the battery vent hose is routed properly and that it's not pinched or restricted in any way.
2. Make sure the spark plug is tight.
3. Fill the fuel tank with fuel.
4. Check all the points listed in the Daily Pre-Ride Inspection section on page 41. *Tightness of the bolts, nuts and other fasteners should be checked by an authorized POLARIS dealer.*
5. Lubricate at the intervals outlined in the Periodic Maintenance Chart beginning on page 59.

Transporting the **RANGER**

Follow these procedures when transporting the vehicle.

1. Apply the brakes.
2. Place the transmission in PARK.
3. Stop the engine.
4. Secure the fuel cap, oil cap and seat.
5. Always tie the frame of the **RANGER** to the transporting unit securely with suitable straps or rope. Do not attach tie straps to the front A-arm bolt pockets.
6. Remove the key to prevent loss during transporting.

SPECIFICATIONS

	RANGER 500 EFI 4X4	RANGER 500 EFI CREW
Maximum Weight Capacity (includes weight of operator, passenger, cargo, accessories)	1000 lbs. (454 kg)	1250 lbs. (567 kg)
Dry Weight	1055 lbs. (478.5 kg)	1300 lbs. (589.7 kg)
Fuel Capacity	8.8 gal. (33.3 l)	8.8 gal. (33.3 l)
Engine Oil Capacity	2 qts. (1.9 l)	2 qts. (1.9 l)
Coolant Capacity	120 oz. (3.5 l)	170 oz. (5 l)
Overall Length	108 in. (274.3 cm)	140 in. (355.6 cm)
Overall Width	56.5 in. (143.5 cm)	58 in. (147.3 cm)
Overall Height	73 in. (185 cm)	73 in. (185 cm)
Wheelbase	72 in. (183 cm)	104 in. (264 cm)
Cargo Box Dimensions (Inside)	32 x 42 x 11.5 in. (81 x 107 x 29 cm)	32 x 42 x 11.5 in. (81 x 107 x 29 cm)
Ground Clearance	10 in. (25.4 cm)	10 in. (25.4 cm)
Min. Turning Radius	150 in. (381 cm)	237 in. (602 cm)
Towing Capacity	1250 lbs. (567 kg)	1250 lbs. (567 kg)
Hitch Tongue Capacity	150 lbs. (68 kg)	150 lbs. (68 kg)
Max. Cargo Box Load	500 lbs. (227 kg)	500 lbs. (227 kg)
Engine	4 valve 4 stroke single cylinder with counter balance	
Displacement	498 cc	498 cc
Bore x Stroke (mm)	92 x 75	92 x 75
Alternator Output	350 W	350 W
Compression Ratio	10.2:1	10.2:1
Starting System	Electric	Electric
Fuel System	Electronic Fuel Injection	Electronic Fuel Injection
Ignition Timing	30° @5000 RPM	30° @5000 RPM
Spark Plug	NGK BKR6E	NGK BKR6E
Lubrication System	Dry Sump	Dry Sump
Cooling	Liquid	Liquid
Front Suspension	Dual A-arm w/9.6 in. (24.4 cm) of travel	Dual A-arm w/9.6 in. (24.4 cm) of travel
Rear Suspension	Independent w/9 in. (23 cm) of travel	Independent w/9 in. (23 cm) of travel

SPECIFICATIONS

	RANGER 500 EFI 4X4	RANGER 500 EFI CREW
Driving System Type	PVT	PVT
Shift Type	Single Lever (console)	Single Lever (console)
Gear Reduction - Low	7.70:1	7.70:1
Gear Reduction - Reverse	7.00:1	7.00:1
Gear Reduction - High	4.12:1	4.12:1
Drive Ratio - Front	3.818:1	3.818:1
Tire Size - Front	25 x 8 - 12	25 x 10 - 12
Tire Size - Rear	25 x 11 - 12	25 x 11 - 12
Tire Pressure - Front	10 psi (68.9 kPa)	14 psi (96.5 kPa)
Tire Pressure - Rear	12 psi (82.7 kPa)	16 psi (110 kPa)
Brakes, Front/Rear	Foot Activated, 4 wheel hydraulic disc	Foot Activated, 4 wheel hydraulic disc
Hood Headlights	2 single beam, 50W, quartz/halogen	2 single beam, 50W, quartz/halogen
Taillights	10 L.E.D. (.28W)	10 L.E.D. (.28W)
Brake Light	10 L.E.D. (3.1W)	10 L.E.D. (3.1W)
Indicator Light	1.0 W	1.0 W

Clutching

See your POLARIS dealer for clutching specifications.

POLARIS PRODUCTS

Part Number	Description
Engine Lubricant	
2870791	Fogging Oil (12 oz./355 ml Aerosol)
2876244	PS-4 PLUS Performance Synthetic 2W-50 4-Cycle Oil (qt./95 l)
2876245	PS-4 PLUS Performance Synthetic 2W-50 4-Cycle Oil (gal./3.8 l)
Gearcase / Transmission Lubricants	
2878068	AGL PLUS Transmission Fluid (qt./95 l)
2878069	AGL PLUS Transmission Fluid (gal./3.8 l)
2877922	Demand Drive Plus Fluid (qt./95 l)
2877923	Demand Drive Plus Fluid (gal./3.8 l)
2871653	Premium ATV Angle Drive Fluid (8 oz./237 ml)
2872276	Premium ATV Angle Drive Fluid (2.5 gal./9.5 l)
2870465	Pump for Gallon (3.8 l) Jug
Coolant	
2871323	60/40 Coolant (gal.)
2871534	60/40 Coolant (qt.)
Grease / Specialized Lubricants	
2871312	Grease Gun Kit, Premium All Season
2871322	Premium All Season Grease (3 oz./89 ml cartridge)
2871423	Premium All Season Grease (14 oz./414 ml cartridge)
2871460	Starter Drive Grease
2871515	Premium U-Joint Lube (3 oz./89 ml cartridge)
2871551	Premium U-Joint Lube (14 oz./414 ml cartridge)
2871329	Dielectric Grease (Nyogel™)
2872073	Chain Lube, Aerosol (6.25 oz.)
2872348	Chain Lube, Aerosol (16 oz.)
Additives / Miscellaneous	
2871326	Carbon Clean Plus
2872189	DOT 4 Brake Fluid
2871956	Loctite™ 565 Thread Sealant
2871076	POLARIS Battery Tender™ Charger

TROUBLESHOOTING

Drive Belt Wear/Burn

Possible Cause	Solution
Driving onto a pickup or tall trailer in high range	Use low range during loading.
Starting out going up a steep incline	Use low range. See warnings on page 46.
Driving at low RPM or ground speed (3-7 MPH)	Drive at a higher speed or use low range more frequently. See page 77.
Insufficient warm-up at low ambient temperatures	Warm the engine at least 5 minutes. With the transmission in neutral, advance the throttle to about 1/8 throttle in short bursts, 5 to 7 times. The belt will become more flexible and prevent belt burning.
Slow/easy clutch engagement	Use the throttle quickly and effectively.
Towing/pushing at low RPM/low ground speed	Use low range only.
Utility use/plowing	Use low range only.
Stuck in mud or snow	Shift the transmission to low range and carefully use fast, aggressive throttle application to engage clutch. WARNING: Excessive throttle may cause loss of control and vehicle overturn.
Climbing over large objects from a stopped position	Shift the transmission to low range and carefully use fast, brief, aggressive throttle application to engage clutch. WARNING: Excessive throttle may cause loss of control and vehicle overturn.
Belt slippage from water or snow ingestion into the PVT system	Dry out the PVT. See page 78. Inspect clutch seals for damage if repeated leaking occurs.
Clutch malfunction	See your POLARIS dealer.
Poor engine performance	Check for fouled plugs or foreign material in fuel tank or fuel lines. See your dealer.
Slippage from failure to warm up belt	Always warm up the belt by operating below 30 mph for one mile (5 miles or more when temperature is below freezing).
Wrong or missing belt	Install the recommended belt.
Improper break-in	Always break in a new belt and/or clutch. See pages 39 and 77.

TROUBLESHOOTING

Engine Doesn't Turn Over

Possible Cause	Solution
Low battery voltage	Recharge the battery to 12.8 VDC
Loose battery connections	Check all connections and tighten
Loose solenoid connections	Check all connections and tighten
Loose electronic control box connections	Inspect, clean, reinstall connectors

Engine Turns Over, Fails to Start

Possible Cause	Solution
Out of fuel	Refuel
Water is present in fuel	Drain the fuel system and refuel
Old or non-recommended fuel	Replace with fresh recommended fuel
Fouled or defective spark plugs	Inspect plugs and replace if necessary
No spark to spark plug	Inspect plugs and replace if necessary
Water or fuel in crankcase	Immediately see your POLARIS dealer
Low battery voltage	Recharge the battery to 12.8 VDC
Mechanical failure	See your dealer

Engine Backfires

Possible Cause	Solution
Weak spark from spark plug	Inspect, clean and/or replace spark plugs
Incorrect spark plug gap or heat range	Set gap to specs or replace plugs
Old or non-recommended fuel	Replace with fresh recommended fuel
Incorrectly installed spark plug wires	See your dealer
Incorrect ignition timing	See your dealer
Mechanical failure	See your dealer
Loose ignition connections	Check all connections and tighten
Water present in fuel	Replace with fresh recommended fuel

TROUBLESHOOTING

Engine Pings or Knocks

Possible Cause	Solution
Poor quality or low octane fuel	Replace with recommended fuel
Incorrect ignition timing	See your dealer
Incorrect spark plug gap or heat range	Set gap to specs or replace plugs

Engine Runs Irregularly, Stalls or Misfires

Possible Cause	Solution
Fouled or defective spark plugs	Inspect, clean and/or replace spark plugs
Worn or defective spark plug wires	See your dealer
Incorrect spark plug gap or heat range	Set gap to specs or replace plugs
Loose ignition connections	Check all connections and tighten
Water present in fuel	Replace with new fuel
Low battery voltage	Recharge battery to 12.8 VDC
Kinked or plugged fuel tank vent line	Inspect and replace
Incorrect fuel	Replace with recommended fuel
Clogged air filter	Inspect and clean or replace
Other mechanical failure	See your dealer
Possible Lean Fuel Cause	Solution
Low or contaminated fuel	Add or change fuel, clean the fuel system
Low octane fuel	Replace with recommended fuel
Possible Rich Fuel Cause	Solution
Fuel is very high octane	Replace with lower octane fuel

TROUBLESHOOTING

Engine Stops or Loses Power

Possible Cause	Solution
Out of fuel	Refuel
Kinked or plugged fuel vent line	Inspect and replace
Water is present in fuel	Replace with new fuel
Fouled or defective spark plugs	Inspect, clean and/or replace spark plug
Worn or defective spark plug wires	See your dealer
Incorrect spark plug gap or heat range	Set gap to specs or replace plug
Loose ignition connections	Check all connections and tighten
Low battery voltage	Recharge the battery to 12.8 VDC
Incorrect fuel	Replace with fresh recommended fuel
Clogged air filter	Inspect and clean or replace
Other mechanical failure	See your dealer
Overheated engine	Clean radiator screen and core, clean engine exterior, see your dealer

DECLARATION OF CONFORMITY

POLARIS Industries Inc.,
2100 Hwy 55, Medina, MN 55340 U.S.A.
Telephone 763-542-0500
April 22, 2010



We, Polaris Industries Inc., declare that the vehicles listed below conform to the essential health and safety requirements applicable to off-road all-terrain vehicles.

APPLICABLE EUROPEAN DIRECTIVES	TEST / EVALUATION METHODS	
2006/42/EC as amended (Machinery Directive)	EN 1050 hazard analysis prEN 15997 driver-perceived noise level prEN 15997 vibration	
2004/108/EC as amended (EMC Directive)	CISPR 12:2009 CAN/CSA-C108.4-M92	EN 55012:2007 EN 61000-6-2:2005

PRODUCT IDENTIFICATION

VEHICLE SERIES	TRADE NAME	MODEL YEARS
KA05 / KA09	OUTLAW 50 / 90	2008, 2009, 2010, 2011
FA09	SPORTSMAN 90	2008, 2009, 2010, 2011
VA17	RZR 170	2009, 2010, 2011
PB20	PHOENIX 200	2008, 2009, 2010, 2011
BA32, NA32	TRAIL BLAZER 330	2008, 2009, 2010, 2011
CA32, EA32	TRAIL BOSS 330	2008, 2009, 2010, 2011
BA50, BG50	SCRAMBLER 500	2008, 2009, 2010, 2011
GJ45	OUTLAW 450	2008, 2009, 2010, 2011
GJ52, GP52	OUTLAW 525 / 525 S	2008, 2009, 2010, 2011
LH46	SPORTSMAN 400	2008, 2009, 2010, 2011
MH50	SPORTSMAN 500 HO	2008, 2009, 2010, 2011
DH50	SPORTSMAN 500 HO TOURING	2010, 2011
ZN55, ZX55	SPORTSMAN 550 EFI	2009, 2010, 2011
TN55, TX55	SPORTSMAN 550 X2	2010, 2011
DN55, DX55	SPORTSMAN 550 TOURING	2010, 2011
MN76	SPORTSMAN 800	2008, 2009, 2010, 2011
CL76, CF76	SPORTSMAN 800 6X6	2009, 2010, 2011
ZN85, ZX85	SPORTSMAN 850 EFI	2009, 2010, 2011
TN85, TX85	SPORTSMAN 850 X2	2010, 2011
DN85, DX85	SPORTSMAN 850 TOURING	2010, 2011
RH45	RANGER 400 / 450	2010, 2011
RH50	RANGER 500 4X4	2010, 2011
TH76	RANGER 800 EFI 4X4	2010, 2011
WH50	RANGER 500 CREW	2011
WH76	RANGER 800 EFI CREW	2010, 2011
HR76	RANGER 800 6X6	2010, 2011
HY76, TY76	RANGER HD 800 4X4	2010, 2011
TH90	RANGER DIESEL	2011
WH90	RANGER DIESEL CREW	2011
VH76, VY76	RANGER RZR / RZR S	2008, 2009, 2010, 2011
XH76	RANGER RZR 4	2011

European Community Person Authorized to Compile the Technical File: Ross Clifford, General Manager Polaris Britain Ltd Forge Mills Park, Station Road Coleshill, Warwickshire B46 1HT	Authorized Manufacturer Signatory Empowered to Draw up the EC Declaration of Conformity: Lawrence E. Keller, Product Compliance Manager 7290 East Viking Blvd. Wyoming, MN 55092
--	---

WARRANTY

LIMITED WARRANTY

POLARIS Sales Inc., 2100 Highway 55, Medina, MN 55340, gives a SIX MONTH LIMITED WARRANTY on all components of the POLARIS *RANGER* against defects in material or workmanship. POLARIS also gives a one year limited warranty on the final drive chain for failure due to defects. This warranty covers the parts and labor charges for repair or replacement of defective parts which are covered by this warranty. This warranty begins on the date of purchase. This warranty is transferable to another consumer during the warranty period through a POLARIS dealer.

REGISTRATION

At the time of sale, the Warranty Registration Form must be completed by your dealer and submitted to POLARIS within ten days. Upon receipt of this registration, POLARIS will record the registration for warranty. No verification of registration will be sent to the purchaser as the copy of the Warranty Registration Form will be the warranty entitlement. If you have not signed the original registration and received the customer copy, please contact your dealer immediately. **NO WARRANTY COVERAGE WILL BE ALLOWED UNLESS YOUR VEHICLE IS REGISTERED WITH POLARIS.**

Initial dealer preparation and set-up of your vehicle is very important in ensuring trouble-free operation. Purchasing a machine in the crate or without proper dealer set-up will void your warranty coverage.

WARRANTY COVERAGE AND EXCLUSIONS: LIMITATIONS OF WARRANTIES AND REMEDIES

The POLARIS limited warranty excludes any failures that are not caused by a defect in material or workmanship. This warranty does not cover accidental damage, normal wear and tear, abuse or improper handling. This warranty also does not cover any vehicle that has been altered structurally, modified, neglected, improperly maintained, used for racing, or used for purposes other than for which it was manufactured, or for any damages which occur during trailer transit or as a result of unauthorized service or the use of unauthorized parts. In addition, this warranty does not cover physical damage to paint or finish, stress cracks, tearing or puncturing of upholstery material, corrosion, or defects in parts, components or the vehicle due to fire, explosions or any other cause beyond POLARIS' control.

Warranty does not apply to parts exposed to friction surfaces, stresses, environmental conditions and/or contamination for which they were not designed or not intended, including but not limited to the following items:

- Wheels and tires
- Suspension components
- Brake components
- Seat components
- Clutches and components
- Steering components
- Batteries
- Light bulbs/Sealed beam lamps
- Finished and unfinished surfaces
- Carburetor/Throttle body components
- Engine components
- Drive belts
- Hydraulic components
- Circuit breakers/Fuses
- Electronic components

WARRANTY

LIMITATIONS OF WARRANTIES AND REMEDIES

Warranty applies to the product only and does not allow for coverage of personal loss. Some items are considered "consumable," meaning they are considered part of normal maintenance or part of completing an effective repair. The following items are excluded from warranty coverage in the event of a warranty claim:

- Spark Plugs
- Filters
- Fuel
- Sealants
- Hotel fees
- Towing charges
- Mileage
- Rentals/Loss of product use
- Lubricants such as oil, grease, etc.
- Batteries (unless defective)
- Cosmetic damage/repair
- Coolants
- Meals
- Shipping/ handling fees
- Product pick-up/delivery
- Loss of vacation/personal time

This warranty also excludes failures resulting from improper lubrication; improper engine timing; improper fuel; surface imperfections caused by external stress, heat, cold or contamination; operator error or abuse; improper component alignment, tension, adjustment or altitude compensation; failure due to snow, water, dirt or other foreign substance ingestion/contamination; improper maintenance; modified components; use of aftermarket components resulting in failure; unauthorized repairs; repairs made after the warranty period expires or by an unauthorized repair center; use of the product in competition or for commercial purposes. Warranty will not apply to any product which has been damaged by abuse, accident, fire or any other casualty not determined a defect of materials or workmanship.

This warranty does not cover the use of unauthorized lubricants, chemicals, or fuels that are not compatible with the vehicle. The exclusive remedy for breach of this warranty shall be, at POLARIS' exclusive option, repair or replacement of any defective materials, or components or products. **THE REMEDIES SET FORTH IN THIS WARRANTY ARE THE ONLY REMEDIES AVAILABLE TO ANY PERSON FOR BREACH OF THIS WARRANTY. POLARIS SHALL HAVE NO LIABILITY TO ANY PERSON FOR INCIDENTAL, CONSEQUENTIAL OR SPECIAL DAMAGES OF ANY DESCRIPTION, WHETHER ARISING OUT OF EXPRESS OR IMPLIED WARRANTY OR ANY OTHER CONTRACT, NEGLIGENCE, OR OTHER TORT OR OTHERWISE. THIS EXCLUSION OF CONSEQUENTIAL, INCIDENTAL, AND SPECIAL DAMAGES IS INDEPENDENT FROM AND SHALL SURVIVE ANY FINDING THAT THE EXCLUSIVE REMEDY FAILED OF ITS ESSENTIAL PURPOSE.** Some states do not permit the exclusion or limitation of incidental or consequential damages or implied warranties, so the above limitations or exclusions may not apply to you if inconsistent with controlling state law.

WARRANTY

LIMITATIONS OF WARRANTIES AND REMEDIES

ALL IMPLIED WARRANTIES (INCLUDING BUT NOT LIMITED TO THE IMPLIED WARRANTIES OF MERCHANTABILITY AND FITNESS FOR A PARTICULAR PURPOSE) ARE LIMITED IN DURATION TO THE ABOVE SIX MONTH WARRANTY PERIOD. POLARIS FURTHER DISCLAIMS ALL EXPRESS WARRANTIES NOT STATED IN THIS WARRANTY. Some states do not allow limitations on how long an implied warranty lasts, so the above limitation may not apply to you if inconsistent with controlling state law.

HOW TO OBTAIN WARRANTY SERVICE

If your vehicle requires warranty service, you must take it to a POLARIS Servicing Dealer. When requesting warranty service you must present your copy of the Warranty Registration form to the dealer. (THE COST OF TRANSPORTATION TO AND FROM THE DEALER IS YOUR RESPONSIBILITY). POLARIS suggests that you use your original selling dealer; however, you may use any POLARIS Servicing Dealer to perform warranty service.

Please work with your dealer to resolve any warranty issues. Should your dealer require any additional assistance they will contact the appropriate person at POLARIS.

This warranty gives you specific legal rights, and you may also have other rights which vary from state to state.

If any of the above terms are void because of state or federal law, all other warranty terms will remain in effect.

Lubricants

1. Mixing oil brands or using non-recommended oil may cause engine damage. We recommend the use of POLARIS engine oil.
2. Damage resulting from the use of non-recommended lubricants may not be covered by warranty.

SPARK ARRESTOR

POLARIS warrants that the spark arrestor in this vehicle will meet the efficiency requirements of USFS standard 5100-1c for at least 1000 hours when subjected to normal use and when maintenance and installation are in accordance with POLARIS recommendations.

Exported Vehicles

EXCEPT WHERE SPECIFICALLY REQUIRED BY LAW, THERE IS NO WARRANTY OR SERVICE BULLETIN COVERAGE ON THIS VEHICLE IF IT IS SOLD OUTSIDE THE COUNTRY OF THE SELLING DEALER'S AUTHORIZED LOCATION.

This policy does not apply to vehicles that have received authorization for export from POLARIS Industries. Dealers may not give authorization for export. You should consult an authorized dealer to determine this vehicle's warranty or service bulletin coverage if you have any questions.

This policy does not apply to vehicles registered to government officials or military personnel on assignment outside the country of the selling dealer's authorized location.

This policy does not apply to Safety Bulletins.

How to Get Service

In the Country where your vehicle was purchased:

Warranty or Service Bulletin repairs must be done by an authorized POLARIS dealer. If you move or are traveling within the country where your vehicle was purchased, Warranty or Service Bulletin repairs may be requested from any authorized POLARIS dealer who sells the same line as your vehicle.

Outside the Country where your vehicle was purchased:

If you are traveling temporarily outside the country where your vehicle was purchased, you should take your vehicle to an authorized POLARIS dealer. You must show the dealer photo identification from the country of the selling dealer's authorized location as proof of residence. Upon residence verification, the servicing dealer will be authorized to perform the warranty repair.

If You Move:

If you move to another country, be sure to contact POLARIS Customer Assistance and the customs department of the destination country before you move. Vehicles importation rules vary considerably from country to country. You may be required to present documentation of your move to POLARIS Industries in order to continue your warranty coverage. You may also be required to obtain documentation from POLARIS Industries in order to register your vehicle in your new country. You should warranty register your vehicle at a local POLARIS dealer in your new country immediately after you move to continue your warranty coverage and to ensure that you receive safety information and notices regarding your vehicle.

WARRANTY

How to Get Service

If Purchased From A Private Party:

If you purchase a POLARIS product from a private citizen, to be kept and used outside of the country in which the vehicle was originally purchased, all warranty coverage will be denied. You must nonetheless warranty register your vehicle under your name and address with a local POLARIS dealer in your country to ensure that you receive safety information and notices regarding your vehicle.

Notice

If your vehicle is registered outside of the country where it was purchased, and you have not followed the procedure set out above, your vehicle will no longer be eligible for warranty or service bulletin coverage of any kind, other than *safety* bulletins. (Vehicles registered to Government officials or military personnel on assignment outside of the country where the vehicle was purchased will continue to be covered by the basic warranty.)

For questions call POLARIS Customer Assistance:

United States: 1-888-704-5290

Canada: 1-204-925-7100

WARRANTY

U.S.A. EPA Emissions Limited Warranty

This emissions limited warranty is in addition to the POLARIS standard limited warranty for your vehicle. POLARIS Industries Inc. warrants that at the time it is first purchased, this emissions-certified vehicle is designed, built and equipped so it conforms with applicable U.S. Environmental Protection Agency emission regulations. POLARIS warrants that the vehicle is free from defects in materials and workmanship that would cause it to fail to meet these regulations.

The warranty period for this emissions-certified vehicle starts on the date the vehicle is first purchased and continues for a period of 500 hours of engine operation, 5000 kilometers (3100 miles) of vehicle travel, or 30 calendar months from the date of purchase, whichever comes first.

This emissions limited warranty covers components whose failure increases the vehicle's regulated emissions, and it covers components of systems whose only purpose is to control emissions. Repairing or replacing other components not covered by this warranty is the responsibility of the vehicle owner. This emissions limited warranty does not cover components whose failure does not increase the vehicle's regulated emissions.

For exhaust emissions, emission-related components include any engine parts related to the following systems:

- Air-induction system
- Fuel system
- Ignition system
- Exhaust gas recirculation systems

The following parts are also considered emission-related components for exhaust emissions:

- Aftertreatment devices
- Crankcase ventilation valves
- Sensors
- Electronic control units

The following parts are considered emission-related components for evaporative emissions:

- Fuel Tank
- Fuel Cap
- Fuel Line
- Fuel Line Fittings
- Clamps*
- Pressure Relief Valves*
- Control Valves*
- Control Solenoids*
- Electronic Controls*
- Vacuum Control Diaphragms*
- Control Cables*
- Control Linkages*
- Purge Valves
- Vapor Hoses
- Liquid/Vapor Separator
- Carbon Canister
- Canister Mounting Brackets
- Carburetor Purge Port Connector

*As related to the evaporative emission control system.

WARRANTY

U.S.A. EPA Emissions Limited Warranty

The exclusive remedy for breach of this limited warranty shall be, at the exclusive option of POLARIS, repair or replacement of any defective materials, components or products. THE REMEDIES SET FORTH IN THIS LIMITED WARRANTY ARE THE ONLY REMEDIES AVAILABLE TO ANY PERSON FOR BREACH OF THIS WARRANTY. POLARIS SHALL HAVE NO LIABILITY TO ANY PERSON FOR INCIDENTAL, CONSEQUENTIAL OR SPECIAL DAMAGES OF ANY DESCRIPTION, WHETHER ARISING OUT OF EXPRESS OR IMPLIED WARRANTY OR ANY OTHER CONTRACT, NEGLIGENCE OR OTHER TORT OR OTHERWISE. THIS EXCLUSION OF CONSEQUENTIAL, INCIDENTAL, AND SPECIAL DAMAGES IS INDEPENDENT FROM AND SHALL SURVIVE ANY FINDING THAT THE EXCLUSIVE REMEDY FAILED OF ITS ESSENTIAL PURPOSE.

ALL IMPLIED WARRANTIES (INCLUDING BUT NOT LIMITED TO ANY IMPLIED WARRANTIES OF MERCHANTABILITY AND FITNESS FOR A PARTICULAR PURPOSE) ARE LIMITED IN DURATION TO THE WARRANTY PERIOD DESCRIBED HEREIN. POLARIS DISCLAIMS ALL EXPRESS WARRANTIES NOT STATED IN THIS WARRANTY. Some states do not allow limitations on how long an implied warranty lasts, so the above limitation may not apply if it is inconsistent with the controlling state law.

This limited warranty excludes failures not caused by a defect in material or workmanship. This limited warranty does not cover damage due to accidents, abuse or improper handling, maintenance or use. This limited warranty also does not cover any engine that has been structurally altered, or when the vehicle has been used in racing competition. This limited warranty also does not cover physical damage, corrosion or defects caused by fire, explosions or other similar causes beyond the control of POLARIS.

Owners are responsible for performing the scheduled maintenance identified in the owner's manual. POLARIS may deny warranty claims for failures that have been caused by the owner's or operator's improper maintenance or use, by accidents for which POLARIS has no responsibility, or by acts of God.

Any qualified repair shop or person may maintain, replace, or repair the emission control devices or systems on your vehicle. POLARIS recommends that you contact an authorized POLARIS dealer to perform any service that may be necessary for your vehicle. POLARIS also recommends that you use only Pure POLARIS parts. It is a potential violation of the Clean Air Act if a part supplied by an aftermarket parts manufacturer reduces the effectiveness of the vehicle's emission controls. Tampering with emission controls is prohibited by federal law.

If you have any questions regarding your warranty rights and responsibilities, please contact the POLARIS Warranty Department at 1-888-704-5290.

INDEX

A

Accessory Outlets	22
Air Filter	80
All Wheel Drive	57
All Wheel Drive Switch	25
Auxiliary Outlets	22
AWD Diagnostics	35
Axle Nut Torque	88

B

Battery	92-96
Charging (Conventional)	95
Charging (Sealed)	96
Fluid (Conventional)	95
Installation	94
Removal	93
Storage	95
Warnings	92
Belt Burning	107
Belt Life	55
Belt Wear	107
Blink Codes	37-38
Brake Fluid	86
Brake Inspection	87
Brake Lights	91
Brake Pedal	25
Brakes	86-87
Braking	42
Break-In Period	39-40
Breather Filter	81

C

Cab Frame, ROPS	30
Cab Nets	28
Cargo	52-53
Cargo Box, Dumping	54
Chart, Periodic Maintenance	59-62
Chrome Wheel Care	100
Cleaning and Storage	98-102

C

Cleaning the Exhaust System	82-83
Cleaning the Spark Arrestor	82-83
Clutching	105
Component Locations	20-21
Console	22-23
Coolant Level, Overflow Bottle	75
Coolant Level, Radiator	76
Coolant, Adding or Changing	74
Cooling Fan	75
Cooling System	74-76
Corrosion Removal, Chrome	100
Crankcase Emission Control System	58
Cylinder Head	85

D

Diagnostic Mode	34-36
Diagnostics, AWD	35
Diagnostics, EFI Blink Codes	38
Diagnostics, Gear Circuit	35
Differential Lock Switch	25
Differential Operation	56
Disengaging AWD	57
Drive Belt Wear	107
Drivetrain Break-In	40
Driving Downhill	47
Driving in Reverse	50
Driving on a Sidehill	47
Driving on Slippery Surfaces	45
Driving Over Obstacles	49
Driving Procedure	43
Driving Through Water	48
Driving Uphill	46
Driving with a Passenger	44
Driving, After Driving in Water	78
Drying the Transmission	78
Dumping the Cargo Box	54

INDEX

E

Emissions Limited Warranty	117-118
Engaging AWD	57
Engine Break-In	40
Engine Fogging	102
Engine Idle Speed	85
Engine Oil	64-68
Engine Speed Display	35
Engine Starting	42
Engine Stopping	42
Equipment Modifications	15
Exhaust Cleaning	82-83
Exhaust Emission Control System	58
Exhaust System Warning	82

F

Filter Systems	80-81
Filter, Air	80
Filter, Breather	81
Fluid, Battery	95

Fluid Change

Engine Oil	66-68
Front Gearcase	71
Main Gearcase	69
Transmission	69

Fluid Level

Coolant (Overflow Bottle)	75
Coolant (Radiator)	76
Engine Oil	65
Front Gearcase	70
Main Gearcase	69
Transmission	69

Fluid Levels During Storage	102
---------------------------------------	-----

Fluid Recommendation

Coolant	74
Engine Oil	64
Gearcases	68
Fluid, Brake	86
Fogging the Engine	102

F

Fouled Plugs	73
Freeplay Adjustment, Throttle	85
Freeplay, Throttle	84
Front Gearcase	70-71
Fuel Cap	29
Fuel Safety	17
Fuel Stabilizer	101
Fuel Tank Filler Cap	29
Fuses	97

G

Gap, Spark Plug	72
Gasoline Handling	17
Gear Circuit Diagnostics	35
Gear Selector	23
Gearcase Specification Chart	68
Gearcase, Front	70-71
Gearcase, Main	69
Gearcases	68-71
Gears, Shifting	23

H

Hauling Cargo	52-53
Headlight Beam Adjustment	91
Headlight Lamp Replacement	90
Hitch Bracket	21
Hitch Weight	55
Hour Meter	33

I

Idle Speed	85
Ignition Switch	24
Immersion of Vehicle	79
Instrument Cluster	31-38

K

Key, Periodic Maintenance Chart	60
Kilometers to Miles Toggle	36

INDEX

L

Light Switch	24
Lights	90-91
Brake Lights	91
Headlight Beam Adjustment	91
Headlight Lamp Replacement	90
Load Capacity	53
Lubricants, Gearcase	68
Lubrication Recommendations	63

M

Main Gearcase	69
Maintenance Log	119-121
Maintenance, Periodic	59, 60-62
Miles to Kilometers Toggle	36
Mode Button	23
Modifications	15

N

Noise Emission Control System	58
---	----

O

Obstacles	49
Odometer	33
Oil, Engine	64-68
Oil Change	
Engine	66-68
Front Gearcase	71
Main Gearcase	69
Transmission	69
Oil Level	
Engine	65
Front Gearcase	70
Main Gearcase	69
Transmission	69
Oil Pump Priming	68
Oil Recommendation	
Engine Oil	64
Gearcases	68
Operation on Public Lands	58
Operator Safety	12-19
Outlets, Auxiliary	22

P

Parking on an Incline	51
Parking the Vehicle	51
Periodic Maintenance Chart	59-62
Plug Gap	72
Plug Torque	72
Plug, Accessory	22
Plugs, Fouled	73
Polaris Products	106
Polishing the Vehicle	99
Pre-Ride Inspection	41
Programmable Service Interval	35
PVT Break-In	40
PVT Drying	78
PVT System	78
PVT System Operation	77
PVT Warning	77

R

Radiator	75
Radiator Coolant Level	76
Removing the Vehicle from Storage	103
Reverse Operation	50
Rider Information Center	32-38
Rollover Protective Structure	30
ROPS Cab Frame	30

S

Safety Labels	7-11
Safety Symbols	4
Seat Belt Inspection	27
Seat Belts	26-27
Seat Removal	29
Service Interval Indicator	35
Service Interval, Programming	36
Severe Use Definition	59
Shifter	23
Shifting Gears	23
Shock Spring Adjustment	87
Signal Words	4
Spark Arrestor Warning	82
Spark Arrestor, Cleaning	82-83

INDEX

S

Spark Plug Gap	72
Spark Plug Inspection	72-73
Spark Plug Recommendations	72
Spark Plug Torque	72
Spark Plugs	72-73
Spark Plugs, Fouled	73
Specifications	104-105
Specifications, Gearcase	68
Speed, Towing	55
Speedometer	31
Starting the Engine	42
Steering Wheel Inspection	87
Stopping the Engine	42
Storage	98-102
Storage Area	102
Storage Compartments	30
Storage Tips	101
Storage, Battery	95
Storage, Covers	102
Storage, Removal from	103
Switches	24-25
AWD Switch	25
Differential Lock Switch	25
Ignition Switch	24
Light Switch	24

T

Tachometer	33, 35
Throttle Freeplay	84
Throttle Freeplay Adjustment	85
Throttle Freeplay Inspection	84
Throttle Pedal	25
Throttle System	84-85
Tires	88-89
Nut Torque	88
Tread Depth	88
Wheel Installation	89
Wheel Removal	89
Torque, Spark Plug	72
Towing Loads	55
Towing Speed	55
Trailer Hitch Bracket	21
Transmission	69
Transmission Operation	77
Transmission System	78
Transmission Warning	77
Transmission, Drying	78
Transporting the Vehicle	103
Trip Meter	33

V

Vehicle Identification Numbers	6
Vehicle Immersion	79
Vehicle Transport	103

W

Warning Symbols	4
Washing the Vehicle	98-99
Weight Capacity	53
Wheel Installation	89
Wheel Nut Torque	88
Wheel Removal	89