

POLARIS[®]
The Way Out.



RANGER
RZR XP™ 900
RZR XP™ 4 900

Owner's Manual
for Maintenance and Safety

 WARNING

Read, understand, and follow all of the instructions and safety precautions in this manual and on all product labels.

Failure to follow the safety precautions could result in serious injury or death.

 WARNING

The engine exhaust from this product contains chemicals known to the State of California to cause cancer, birth defects or other reproductive harm.

WELCOME

Thank you for purchasing a POLARIS vehicle, and welcome to our world-wide family of POLARIS owners. We proudly produce an exciting line of utility and recreational products.

- Snowmobiles
- All-terrain vehicles (ATVs)
- *RANGER*® utility vehicles
- Victory Motorcycles®
- Low Emission Vehicles (LEVs)

We believe POLARIS sets a standard of excellence for all utility and recreational vehicles manufactured in the world today. Many years of experience have gone into the engineering, design, and development of your POLARIS vehicle, making it the finest machine we've ever produced.

For safe and enjoyable operation of your vehicle, be sure to follow the instructions and recommendations in this owner's manual. Visit the Recreational Off-Highway Vehicle Association web site (rohva.org) and take the free on-line training course.

Your owner's manual contains instructions for minor maintenance, but information about major repairs is outlined in the POLARIS Service Manual and should be performed only by a factory certified Master Service Dealer® (MSD) Technician.

Your POLARIS dealer knows your vehicle best and is interested in your total satisfaction. Be sure to return to your dealership for all of your service needs during, and after, the warranty period.

We also take great pride in our complete line of apparel, parts and accessories, available through our online store at www.purepolaris.com. Have your accessories and clothing delivered right to your door!



POLARIS[®]
The Way Out.

POLARIS, THE WAY OUT, *RANGER* and *RANGER RZR* are registered trademarks of POLARIS Industries Inc.

RANGER RZR XP is a trademark of POLARIS Industries Inc.

Copyright 2011 POLARIS Sales Inc. All information contained within this publication is based on the latest product information at the time of publication. Due to constant improvements in the design and quality of production components, some minor discrepancies may result between the actual vehicle and the information presented in this publication. Depictions and/or procedures in this publication are intended for reference use only. No liability can be accepted for omissions or inaccuracies. Any reprinting or reuse of the depictions and/or procedures contained within, whether whole or in part, is expressly prohibited.

The original instructions for this vehicle are in English. Other languages are provided as translations of the original instructions.

Printed in U.S.A.

2012 *RANGER RZR XP 900* / *RANGER RZR XP 4 900* Owner's Manual

P/N 9923625

TABLE OF CONTENTS

Introduction	4
Safety	7
Features and Controls	28
Operation	50
Emission Control Systems	68
Maintenance	69
Specifications	120
POLARIS Products	124
Troubleshooting	125
Warranty	129
Maintenance Log	137
Index	140

INTRODUCTION

The following signal words and symbols appear throughout this manual and on your vehicle. Your safety is involved when these words and symbols are used. Become familiar with their meanings before reading the manual.



The safety alert symbol indicates a potential personal injury hazard.

WARNING

A **WARNING** indicates a hazardous situation which, if not avoided, may result in death or serious injury.

CAUTION

A **CAUTION** indicates a hazardous situation which, if not avoided, may result in minor or moderate injury.

NOTICE

A **NOTICE** indicates a situation that may result in property damage.



The Prohibition Safety Sign indicates an action **NOT** to take in order to avoid a hazard.



The Mandatory Action Sign indicates an action that **NEEDS** to be taken to avoid a hazard.

⚠ WARNING

Failure to heed the warnings and safety precautions contained in this manual can result in severe injury or death. Your POLARIS vehicle is not a toy and can be hazardous to operate. This vehicle handles differently than cars, trucks or other off-road vehicles. A collision or rollover can occur quickly, even during routine maneuvers like turning, or driving on hills or over obstacles, if you fail to take proper precautions.

- Read this owner's manual. Understand all safety warnings, precautions and operating procedures before operating the vehicle. Keep this manual with the vehicle.
- Visit the Recreational Off-Highway Vehicle Association web site (rohva.org) and take the free on-line training course.
- Complete the New Operator Driving Procedures outlined on pages 56-57. Never allow a guest to operate this vehicle until the guest has completed the New Operator Driving Procedures.
- This vehicle is an ADULT VEHICLE ONLY. Operation is prohibited for anyone under 16 years of age or anyone without a valid driver's license.

European Vibration and Noise

The driver-perceived noise and hand/arm and whole body vibration levels of this machinery is measured per prEN 15997.

The operating conditions of the machinery during testing:

The vehicles were in like-new condition. The environment was controlled as indicated by the test procedure(s).

The uncertainty of vibration exposure measurement is dependent on many factors, including:

- Instrument and calibration uncertainty
- Variations in the machine such as wear of components
- Variation of machine operators such as experience or physique
- Ability of the worker to reproduce typical work during measurements
- Environmental factors such as ambient noise or temperature

INTRODUCTION

Vehicle Identification Numbers

Record your vehicle's identification numbers and key number in the spaces provided. Remove the spare key and store it in a safe place. An ignition key can be duplicated only by ordering a POLARIS key blank (using your key number) and mating it with one of your existing keys. The ignition switch must be replaced if all keys are lost.

Vehicle Identification Number

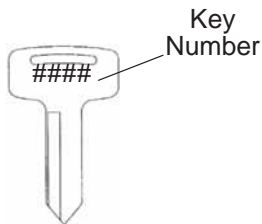

Engine Serial Number

Vehicle Model Number: _____

Vehicle Identification Number: _____

Engine Serial Number: _____

Key Number _____

Equipment Modifications

Your POLARIS vehicle is designed to provide safe operation when used as directed. Modifications to your vehicle may negatively impact vehicle stability. Failure of critical machine components may result from operation with any modifications, especially those that increase speed or power. This vehicle may become less stable at speeds higher than those for which it is designed. Loss of control may occur at higher speeds.

Do not install on a POLARIS vehicle any equipment that may increase the speed or power of the vehicle, or make any other modifications to the vehicle for these purposes. Any modifications to the original equipment of the vehicle create a substantial safety hazard and increase the risk of bodily injury.

The warranty on your POLARIS vehicle is terminated if any equipment has been added to the vehicle, or if any modifications have been made to the vehicle, that increase its speed or power.

The addition of certain accessories, including (but not limited to) mowers, blades, tires, sprayers, or large racks, may change the handling characteristics of the vehicle. Use only POLARIS-approved accessories, and familiarize yourself with their function and effect on the vehicle.

SAFETY

Safe Riding Gear

Always wear appropriate clothing when riding a POLARIS vehicle. Wear protective clothing for comfort and to reduce the chance of injury.

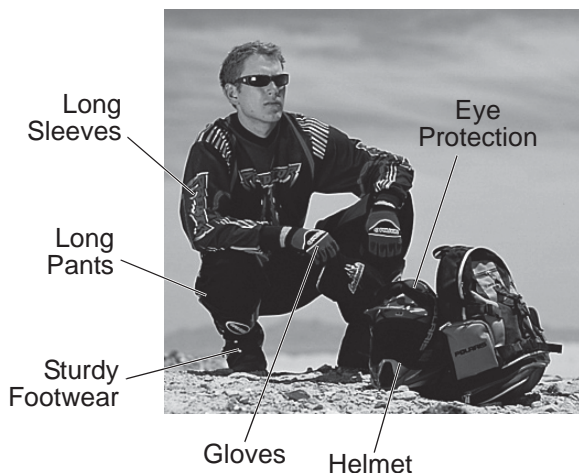

Helmet

Wearing a helmet can prevent a severe head injury. Whenever riding this POLARIS vehicle, always wear a helmet that meets or exceeds established safety standards.

Approved helmets in the USA and Canada bear a U.S. Department of Transportation (DOT) label.

Approved helmets in Europe, Asia and Oceania bear the ECE 22.05 label. The ECE mark consists of a circle surrounding the letter E, followed by the distinguishing number of the country which has granted approval. The approval number and serial number will also be displayed on the label.

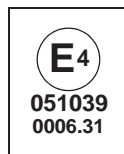

Safe Riding Gear

Eye Protection

Do not depend on eyeglasses or sunglasses for eye protection. Whenever riding a POLARIS vehicle, always wear shatterproof goggles or use a shatterproof helmet face shield. POLARIS recommends wearing approved Personal Protective Equipment (PPE) bearing markings such as VESC 8, V-8, Z87.1, or CE. Make sure protective eye wear is kept clean.

Gloves

Wear gloves for comfort and for protection from sun, cold weather and other elements.

Boots

Wear sturdy footwear. Do not ride a POLARIS vehicle with bare feet.

Clothing

Wear long sleeves and long pants to protect arms and legs.

SAFETY

Safety Warnings

⚠ WARNING

Failure to operate this vehicle properly can result in a collision, loss of control, accident or overturn, which may result in serious injury or death. Heed all safety warnings outlined in this section of the owner's manual. See the OPERATION section of the owner's manual for proper operating procedures.

Operating Without Instruction

Operating this vehicle without proper instruction increases the risk of an accident. The operator must understand how to operate the vehicle properly in different situations and on different types of terrain. Take a training course and complete the New Operator Driving Procedures outlined on pages 56-57.

All operators must read and understand the owner's manual and all warning and instruction labels before operating the vehicle. Never allow a guest to operate this vehicle until the guest has completed the New Operator Driving Procedures outlined on pages 56-57.

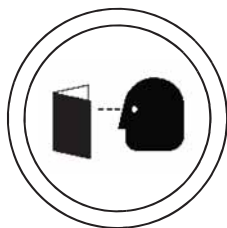

Operator Restrictions/Age Restrictions

This vehicle is an ADULT VEHICLE ONLY. Operation is prohibited for anyone under 16 years of age or anyone without a valid driver's license. Never operate with a passenger under the age of 12. Make sure all passengers are tall enough to comfortably and safely reach the hand holds and place both feet on the floor.

Accessories

Non-approved accessories may seriously affect vehicle stability. Using accessories not approved by POLARIS for use on this vehicle could cause loss of control or an accident. Never operate with accessories not approved by POLARIS for use on this vehicle.

Using Alcohol or Drugs

Riding in this vehicle after consuming alcohol or drugs could adversely affect operator judgment, reaction time, balance and perception.

Never consume alcohol or drugs before or while operating or riding in this vehicle.



Safety Warnings

Failure to Inspect Before Operating

Failure to inspect and verify that the vehicle is in safe operating condition before operating increases the risk of an accident.

Always inspect the vehicle before each use to make sure it's in safe operating condition.

Always follow the inspection and maintenance procedures and schedules described in the owner's manual.

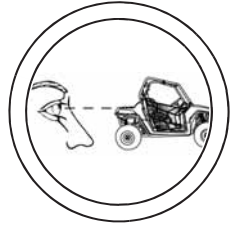

Protective Apparel

Riding in this vehicle without wearing an approved helmet and protective eyewear increases the risk of a serious injuries in the event of an accident.

Operator and all passengers must always wear an approved helmet that fits properly and eye protection (goggles or face shield).



Seat Belts

Riding in this vehicle without wearing the seat belt increases the risk of serious injury in the event of an accident or sudden stop. Riders *must* wear seat belts at all times. Seat belts reduce the severity of injury in the event of a sudden stop or accident. Always make sure the seat belts are secured for both the operator and all passengers before riding.

Cab Nets

Riding in this vehicle without using the cab nets increases the risk of serious injury or death in the event of an accident or overturn. Always use the cab nets while riding in this vehicle.

Always keep hands and feet inside the vehicle at all times.

Carrying Passengers (RZR XP 4)

Never carry a passenger until you have operated this vehicle for at least two hours and have completed the New Operator Driving Procedures outlined on pages 56-57.

A passenger must always be seated in a passenger seat with seat belt secured.

Never carry more than three passengers in a 4-seat vehicle.

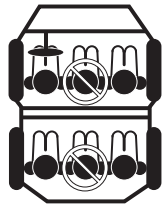

SAFETY

Safety Warnings

Carrying Multiple Passengers (RZR XP)

Never carry a passenger until you have operated this vehicle for at least two hours and have completed the New Operator Driving Procedures outlined on pages 56-57.

A passenger must always be seated in a passenger seat with seat belt secured. Carrying more than one passenger in a 2-seat vehicle can affect the operator's ability to steer and operate the controls, which increases the risk of loss of control and accident or overturn. Never carry more than one passenger in a 2-seat vehicle.



Operating With a Load on the Vehicle

The weight of both cargo and passengers impacts vehicle operation. For your safety and the safety of others, carefully consider how your vehicle is loaded and how to safely operate the vehicle. Follow the instructions in this manual for loading, tire pressure, gear selection and speed.

- **Do not exceed vehicle weight capacities.** The vehicle's maximum weight capacity is listed in the specifications section of this manual and on a label on the vehicle. When more passenger weight is added, cargo weight may need to be reduced accordingly.
- The recommended tire pressures are listed in the specifications section of this manual and on a label on the vehicle.

Always follow these guidelines:

Under ANY of these conditions:	Do ALL of these steps:
Passenger and/or cargo exceeds half the maximum weight capacity	1. Slow down. 2. Verify tire pressure. 3. Use extra caution when operating.
Operating in rough terrain	
Operating over obstacles	
Climbing an incline	
Towing	

Safety Warnings

Passengers in the Cargo Box

Carrying a passenger in the cargo box could result in a fall from the vehicle or contact with moving components. Never allow a passenger to ride in the cargo box. A passenger must always be seated in the passenger seat with seat belt secured.

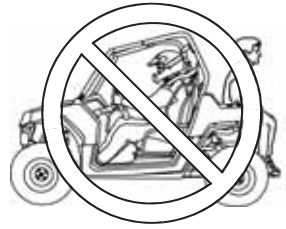

Operating on Pavement

Operating this vehicle on paved surfaces (including sidewalks, paths, parking lots, and driveways) may seriously affect handling and control of the vehicle, and may cause the vehicle to go out of control. This vehicle's tires are designed for off-road use only, not for use on pavement.

Avoid operating the vehicle on pavement. If you must operate on a paved surface, travel slowly and do not make sudden turns or stops.

Operating on Public Roads

Operating this vehicle on public streets, roads or highways could result in a collision with another vehicle.

Never operate this vehicle on any public street, road or highway, including dirt and gravel roads.

In many areas it's illegal to operate vehicles of this type on public streets, roads and highways.



Operating at Excessive Speeds

Operating this vehicle at excessive speeds increases the operator's risk of losing control.

Always operate at a speed that's appropriate for the terrain, the visibility and operating conditions, your skills and your passenger's skills.

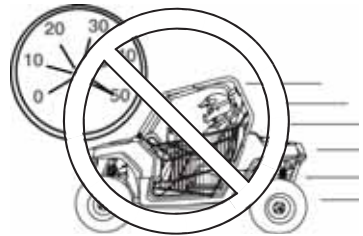

SAFETY

Safety Warnings

Turning Improperly

Turning improperly could cause loss of traction, loss of control, accident or overturn. Always follow proper procedures for turning as described in the owner's manual.

Avoid sharp turns. Never turn while applying heavy throttle. Never make abrupt steering maneuvers. Practice turning at slow speeds before attempting to turn at faster speeds.

Physical Control of the Vehicle

Removing hands from the steering wheel or hand hold or removing feet from the floor while riding increases the risk of loss of control and accident or overturn.

The operator should always keep both hands on the steering wheel during operation. Passengers should always be seated in a passenger seat with seat belt secured, with both feet on the floor and with both hands securely grasping the passenger hand hold or grab bar.

Always keep hands and feet inside the vehicle at all times.

Jumps and Stunts

Exhibition driving increases the risk of an accident or overturn. **DO NOT** do power slides, "donuts", jumps or other driving stunts. Avoid exhibition driving.

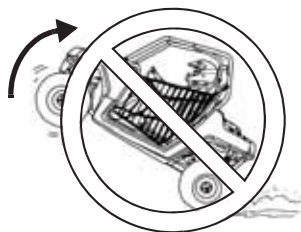

Descending Hills Improperly

Improperly descending a hill could cause loss of control or overturn. Always follow proper procedures for traveling down hills as described in the owner's manual.

- Always descend a hill with the transmission in forward gear. Never descend a hill with the transmission in neutral.
- Always check the terrain carefully before descending a hill.
- Never travel down a hill at high speed.
- Avoid traveling down a hill at an angle, which would cause the vehicle to lean sharply to one side. Travel straight downhill.

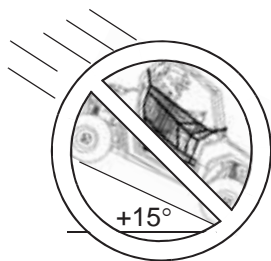

Safety Warnings

Improper Hill Climbing

Improper hill climbing could cause loss of control or overturn. Use extreme caution when operating on hills. Always follow proper procedures for hill climbing as described in the owner's manual. See page 60.

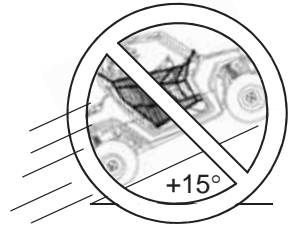

Crossing Hillsides

Driving on a sidehill is not recommended. Improper procedure could cause loss of control or overturn. Avoid crossing the side of any hill unless absolutely necessary.

If crossing a hillside is unavoidable, always follow proper procedures as described in the owner's manual. See page 61.

Stalling While Climbing a Hill

Stalling or rolling backwards while climbing a hill could cause an overturn. Maintain a steady speed when climbing a hill.

If you lose all forward speed:

Apply the brakes gradually until the vehicle is fully stopped. Place the transmission in reverse and slowly allow the vehicle to roll straight downhill while applying light brake pressure to control speed.



Operating in Unfamiliar Terrain

Failure to use extra caution when operating on unfamiliar terrain could result in an accident or overturn.

Unfamiliar terrain may contain hidden rocks, bumps, or holes that could cause loss of control or overturn.

Travel slowly and use extra caution when operating on unfamiliar terrain. Always be alert to changing terrain conditions.



SAFETY

Safety Warnings

Operating Improperly in Reverse

Improperly operating in reverse could result in a collision with an obstacle or person. Always follow proper operating procedures as outlined in this manual. See page 64.

Before shifting into reverse gear, always check for obstacles or people behind the vehicle. When it's safe to proceed, back slowly.

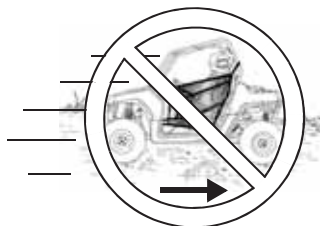

Improper Tire Maintenance

Operating this vehicle with improper tires or with improper or uneven tire pressure could cause loss of control, accident or overturn.

Always use the size and type of tires specified for your vehicle. Always maintain proper tire pressure as described in the owner's manual and on safety labels.

Operating on Slippery Terrain

Operating on excessively rough, slippery or loose terrain could cause loss of traction, loss of control, accident or overturn.

Do not operate on excessively rough, slippery or loose terrain. Always use extra caution on rough, slippery or loose terrain.

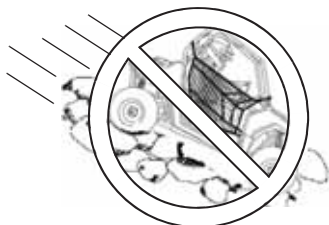

Safety Warnings

Operating Over Obstacles

Improperly operating over obstacles could cause loss of control or overturn.

Before operating in a new area, check for obstacles. Never attempt to operate over large obstacles such as rocks or fallen trees. Always follow the proper procedures outlined in this manual when operating over obstacles.



Skidding or Sliding

Skidding or sliding can cause loss of control or overturn (if tires regain traction unexpectedly). Always follow proper procedures for operating on slippery surfaces as described in the owner's manual.

When operating on slippery surfaces such as ice or loose gravel, reduce speed and use extra caution to reduce the chance of skidding or sliding.

Do not operate on excessively slippery surfaces.

Operating Through Water

Operating through deep or fast-flowing water can cause loss of traction, loss of control, overturn or accident. Never operate in fast-flowing water or in water that exceeds the recommended maximum depth.

Always follow proper procedures for operating in water as described in the owner's manual.

Wet brakes may have reduced stopping ability. After leaving water, test the brakes. Apply them lightly several times while driving slowly. The friction will help dry out the pads.



SAFETY

Safety Warnings

Improper Cargo Loading

Overloading the vehicle or carrying cargo improperly may cause changes in stability and handling, which could cause loss of control or an accident.

- Always follow the instructions in the owner's manual for carrying cargo.
- Never exceed the stated load capacity for this vehicle.
- Cargo should be properly distributed and securely attached.
- Reduce speed when carrying cargo. Allow a greater distance for braking.

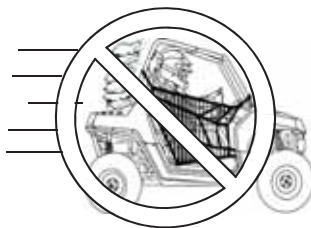

Operating on Frozen Bodies of Water

Severe injury or death can result if the vehicle and/or the operator fall through the ice. Never operate the vehicle on a frozen body of water unless you have first verified that the ice is sufficiently thick to support the weight and moving force of the vehicle, you and your passengers, and your cargo, together with any other vehicles in your party. Always check with local authorities and residents to confirm ice conditions and thickness over your entire route. Vehicle operators assume all risk associated with ice conditions on frozen bodies of water.



Operating a Damaged Vehicle

Operating a damaged vehicle can result in an accident with serious injury or death. After any overturn or accident, have a qualified service dealer inspect the entire vehicle for possible damage, including (but not limited to) brakes, throttle and steering systems.

Safety Warnings

Handling Gasoline

Gasoline is highly flammable and is explosive under certain conditions. Always exercise extreme caution whenever handling gasoline.

- Always stop the engine when refueling.
- Always refuel outdoors or in a well ventilated area.
- Remove flammable material containers from the box before filling.
- Do not smoke or allow open flames or sparks in or near the refueling area or where gasoline is stored.
- Never refuel while a person is in the vehicle.
- Do not over fill the tank. Do not fill the tank neck.
- If gasoline spills on your skin or clothing, immediately wash it off with soap and water and change clothing.

Refueling

Always turn off the engine before refueling. Make sure the refueling area is well ventilated and free of any source of flame or sparks. Gasoline is extremely flammable.

Remove flammable material containers from the box before filling.

Exposure to Exhaust

Engine exhaust fumes are poisonous and can cause loss of consciousness or death in a short time. Never start the engine or let it run in an enclosed area.

Operate this vehicle only outdoors or in well-ventilated areas.

Hot Exhaust Systems

Exhaust system components are very hot during and after use of the vehicle. Hot components can cause burns and fire. Do not touch hot exhaust system components. Always keep combustible materials away from the exhaust system. Use caution when traveling through tall grass, especially dry grass.

Unauthorized Use of the Vehicle

Leaving the keys in the ignition can lead to unauthorized use of the vehicle, which could result in an accident or overturn. Always remove the ignition key when the vehicle is not in use.

**FOR MORE INFORMATION ABOUT SAFETY
call POLARIS at 1-800-342-3764.**

SAFETY

Safety Labels and Locations

Warning labels have been placed on the vehicle for your protection. Read and follow the instructions of the labels on the vehicle carefully. If any of the labels depicted in this manual differ from the labels on your vehicle, always read and follow the instructions of the *labels on the vehicle*.

If an informational or graphic label becomes illegible or comes off, contact your POLARIS dealer to purchase a replacement. Replacement *safety* labels are provided by POLARIS at no charge. The part number is printed on the label.

Load/Passenger/Tire Pressure Warning

WARNING

- Passengers can be thrown off. This can cause serious injury or death.
- Never carry passengers in cargo box.

WARNING

IMPROPER TIRE PRESSURE OR OVERLOADING CAN CAUSE LOSS OF CONTROL RESULTING IN SERIOUS INJURY OR DEATH.

- Reduce speed and allow greater distance for braking when carrying cargo.
- Overloading or carrying tall, off-center, or unsecured loads will increase your risk of losing control. Loads should be centered and carried as low as possible in box.
- For stability on rough or hilly terrain, reduce speed and cargo.
- Be careful if load extends over the side of the box.

Load/Passenger/Tire Pressure Warning



<i>RANGER</i>	RZR	RZR 4	RZR XP	RZR XP 4
MAXIMUM CARGO BOX LOAD	300 lbs. (136 kg)	300 lbs. (136 kg)	300 lbs. (136 kg)	300 lbs. (136 kg)
TIRE PRESSURE IN PSI (KPa)	FRONT 8 (55) REAR 8 (55)	FRONT 10 (69) REAR 12 (83)	FRONT 12 (83) REAR 14 (97)	FRONT 14 (97) REAR 16 (110)
MAXIMUM WEIGHT CAPACITY INCLUDES WEIGHT OF OPERATOR, PASSENGER, CARGO AND ACCESSORIES	740 lbs. (336 kg)	900 lbs. (408 kg)	740 lbs. (336 kg)	900 lbs. (408 kg)
Read Operation and Maintenance Manual for more detailed loading information.				

Safety Labels and Locations



Passenger
Safety
Warning

Passenger Safety Warning (RZR XP)

WARNING

NEVER CARRY A PASSENGER UNDER AGE 12
NEVER CARRY MORE THAN ONE PASSENGER
NEVER RIDE AFTER USING DRUGS OR ALCOHOL

To reduce the risk of SEVERE INJURY or DEATH,
NEVER carry a passenger under age 12 or too small to
firmly plant feet on the floor and securely grasp hand hold.

THE PASSENGER MUST ALWAYS:

- wear seat belt.
- use an approved helmet and protective gear.
- securely grasp hand hold and plant feet firmly on the floor.
- tell operator to slow down or stop if uncomfortable - get off and walk if conditions require.
- keep hands and feet inside vehicle at all times.
- watch for branches, brush, and other hazards that could enter vehicle.



7175102

SAFETY

Safety Labels and Locations

Passenger Safety Warning (RZR XP 4)

WARNING

NEVER CARRY PASSENGERS UNDER AGE 12

NEVER CARRY MORE THAN THREE PASSENGERS

NEVER RIDE AFTER USING DRUGS OR ALCOHOL

To reduce the risk of SEVERE INJURY or DEATH,
NEVER carry passengers under age 12 or too small to firmly plant feet on the floor and securely grasp hand holds.

THE PASSENGERS MUST ALWAYS:

- wear seat belts.
- use approved helmets and protective gear.
- securely grasp hand holds and plant feet firmly on the floor.
- tell operator to slow down or stop if uncomfortable - get off and walk if conditions require.
- keep hands and feet inside vehicle at all times.
- avoid branches, brush and other hazards that could enter vehicle.



7176608

Safety Labels and Locations

Rear Passenger Cab Frame Warning (RZR XP 4)

WARNING

Do NOT hold onto this bar. Hands and arms could be crushed or seriously injured in event of rollover.

ALWAYS keep hands on passenger grab bar.
7176700

Rear Passenger Grab Bar Warning (RZR XP 4)

Always use seat belt, helmet and eye protection.

Always use passenger grab bar and side nets to keep hands and feet in vehicle at all times.
7176701

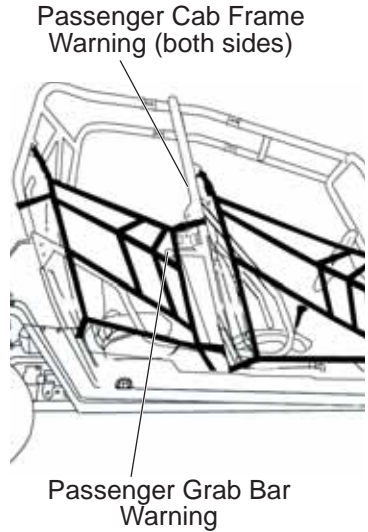

SAFETY

Safety Labels and Locations

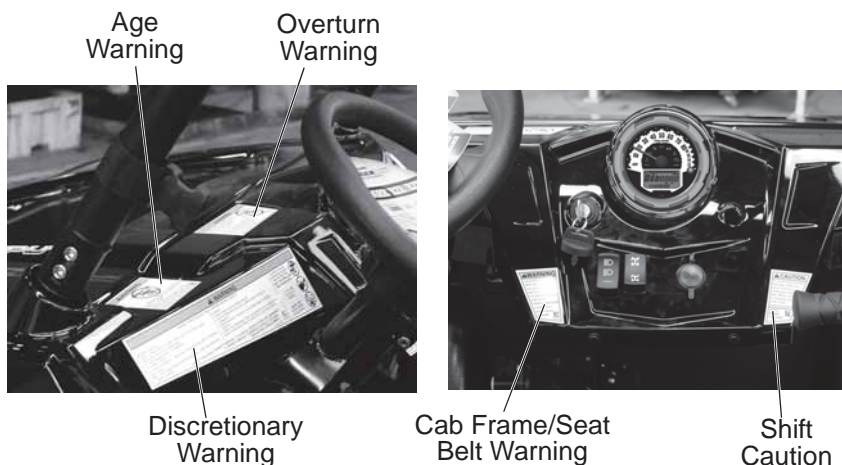

Cab Frame/Seat Belt Warning

WARNING

- ALWAYS WEAR YOUR SEAT BELT and make sure passenger wears seat belt.
- ALWAYS SECURE CAB NETS.
- VEHICLE OVERTURN could cause severe injury or death.

Shift Caution

CAUTION

To avoid transmission damage, shift only when vehicle is stationary and at idle. When vehicle is stopped, place shift in the parked position.

APPLY BRAKE TO START

7174843

Safety Labels and Locations

Age Warning

WARNING

Operating this vehicle if you are under the age of 16 increases your chance of severe injury or death.

NEVER operate this vehicle if you are under age 16 or without a valid driver's license.



Overturn Warning

WARNING

Improper operation can cause this vehicle to overturn and lead to serious injury or death.

This vehicle handles differently than cars, trucks or other off-road vehicles. In order to avoid overturns:

- avoid sharp turns.
- never turn while applying heavy throttle.
- never make abrupt steering maneuvers.
- operate at speeds appropriate for your skills, the conditions and the terrain.
- DO NOT do power slides, "donuts", jumps or other driving stunts.



7175105

Belt Debris Warning

WARNING

Improper service or maintenance of this PVT system can result in vehicle damage, SEVERE INJURY or DEATH.

Always look for and remove debris inside and around the clutch and vent system when replacing the belt.

Read owner's manual or see authorized POLARIS dealer.

7177469

SAFETY

Safety Labels and Locations

Discretionary Warning (RZR XP)

WARNING

Improper vehicle use can result in SEVERE INJURY or DEATH

NEVER operate:

- without first viewing safety video and quick start guide.
- with more than one passenger.
- on hills steeper than 15 degrees.
- on public roads.
- on paved surfaces - pavement may seriously affect handling and control.
- with non-POLARIS approved accessories - they may seriously affect stability.

ALWAYS:

- keep hands and feet inside vehicle. Use the cab nets.
- reduce speed and use extra caution when carrying a passenger.
- operate slowly in reverse - avoid sharp turns or sudden braking.
- make sure passenger reads and understands all safety labels.
- watch for branches or other hazards that could enter vehicle.

ALWAYS USE AN APPROVED HELMET AND PROTECTIVE GEAR FOR OPERATOR AND PASSENGER

NEVER USE ON PUBLIC ROADS

NEVER USE WITH DRUGS OR ALCOHOL

LOCATE AND READ OWNER'S MANUAL. FOLLOW ALL INSTRUCTIONS AND WARNINGS. IF OWNER'S MANUAL IS MISSING, CONTACT A POLARIS DEALER FOR A REPLACEMENT.



Discretionary Warning



7175104

Safety Labels and Locations Discretionary Warning (RZR XP 4)

WARNING

Improper vehicle use can result in SEVERE INJURY or DEATH

NEVER operate:

- without first viewing safety video and quick start guide.
- with more than three passengers.
- on hills steeper than 15 degrees.
- on public roads.
- on paved surfaces - pavement may seriously affect handling and control.
- with non-POLARIS approved accessories - they may seriously affect stability.

ALWAYS:

- keep hands and feet inside vehicle.
- reduce speed and use extra caution when carrying passengers.
- operate slowly in reverse - avoid sharp turns or sudden braking.
- make sure passengers read and understand all safety labels.
- avoid branches or other hazards that could enter vehicle.

ALWAYS USE AN APPROVED HELMET AND PROTECTIVE GEAR FOR OPERATOR AND PASSENGERS

NEVER USE ON PUBLIC ROADS

NEVER USE WITH DRUGS OR ALCOHOL

LOCATE AND READ OWNER'S MANUAL. FOLLOW ALL INSTRUCTIONS AND WARNINGS. IF OWNER'S MANUAL IS MISSING, CONTACT A POLARIS DEALER FOR A REPLACEMENT.



7176607

FEATURES AND CONTROLS

Component Locations

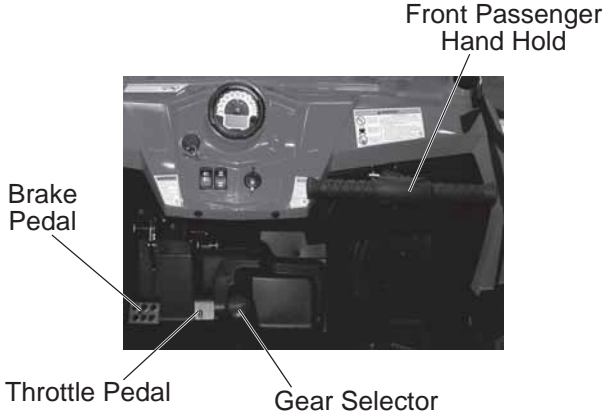

FEATURES AND CONTROLS

Component Locations

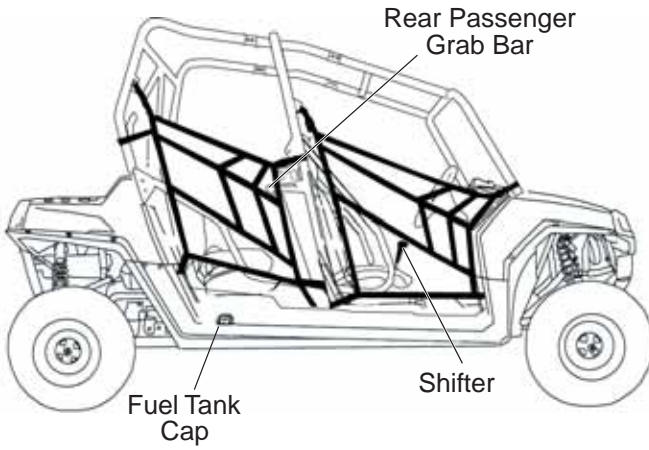

Cargo Box
Tie-Down
Points

FEATURES AND CONTROLS

Switches

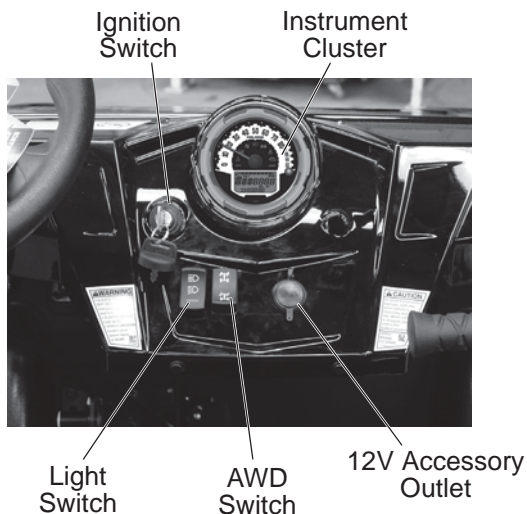

Auxiliary Outlets

The vehicle is equipped with one or more 12-volt accessory outlets. One outlet is on the dash, a second outlet (if equipped) is in the rear passenger area. Use the outlets to power an auxiliary light or other optional accessories or lights. For service, the dash outlet connection is under the dash. The rear outlet connection is under the rear passenger seats.

Ignition Switch

The ignition switch is a three-position, key-operated switch. Use the ignition switch to start the engine. See page 54 for starting procedures.

The key can be removed from the switch when it is in the OFF position.

OFF	The engine is off. Electrical circuits are off, except accessory 12V.
ON	Electrical circuits are on. Electrical equipment can be used.
START	Turn the key to the START position to engage the electric starter. The key returns to the ON position when released.

FEATURES AND CONTROLS

Switches

Headlight Switch

Use the headlight switch to turn the lights on and off and to change the lights from high beam to low beam. The ignition switch must be in the ON position to operate the headlights.

Press the top of the rocker switch toward the dash to place the headlights on high beam. Move the rocker switch to the center position to place the headlights on low beam. Press the bottom of the rocker switch to turn off the headlights.

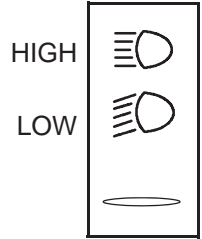

All Wheel Drive (AWD) Switch

The AWD Switch has two positions:

- All Wheel Drive (AWD)
- Two Wheel Drive (2WD).

Press the top of the rocker switch to engage All Wheel Drive. Press the bottom of the switch to operate in two wheel drive.

See page 40 for AWD operating instructions.

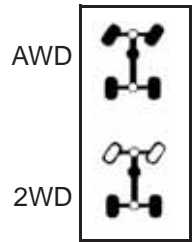

FEATURES AND CONTROLS

Seats

Before operating the vehicle, always push down on all seat backs to ensure the latches are secure.

Seat Adjustments

Loosen (do not remove) the four screws located on the seat bottom. Slide the seat forward or rearward to the desired position. Tighten the screws to 4 ft. lbs. (5.4 Nm). Do not overtighten.

Seat Removal

1. Pull up on the seat latch lever located under the rear edge of the seat.
2. Tilt the seat forward.
3. Lift the seat upward to remove it from the vehicle.
4. Reverse this procedure to reinstall the seat. Make sure the seat tabs at the front edge of the seat slide under the seat retainer bar.
5. Press down firmly at the rear of the seat to engage the rear latch.



Front Seat Retainer

Seat Latch

Steering Wheel

The steering wheel can be tilted upward or downward for rider preference.

Lift and hold the steering wheel adjustment lever while moving the steering wheel upward or downward. Release the lever when the steering wheel is at the desired position.



Adjustment Lever

FEATURES AND CONTROLS

Passenger Hand Hold

Always adjust the hand hold to a comfortable position for your front-seat passenger before operating. Make sure the adjustment pin and retainer are securely installed after making adjustments.

1. Remove the retainer from the end of the adjustment pin.
2. Remove the pin from the post.
3. Slide the post inward or outward to the desired position.
4. Reinstall the pin through the post mounting hole, adapter bushing hole, both post adjustment holes and lastly through the remaining bushing hole and post mounting hole.
5. Reinstall the retainer to the pin.

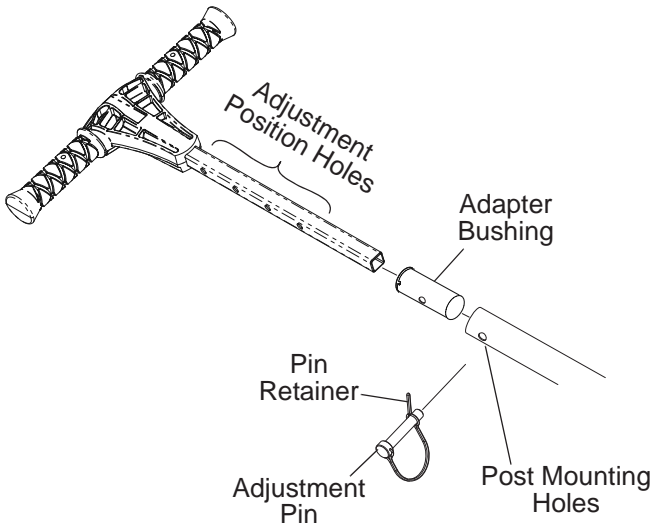

FEATURES AND CONTROLS

Hood

Remove the hood to access the radiator pressure cap and coolant overflow bottle.

1. Turn the hood fasteners 1/4 turn.
2. Grasp the upper hood edge and pull upward to disengage the fasteners.
3. Pivot the hood forward and lift upward to disengage the lower hood hooks.
4. Lift the hood away from the vehicle.

Hood Fasteners



Pressure Cap

Overflow Bottle



FEATURES AND CONTROLS

Service Access Panels

Engine Access Panel

The engine access panel is located behind the seats on the frame of the vehicle. Remove the seats and remove the access panel to reach some serviceable engine components.



Oil Tank Access Panel

The oil tank access panel is located in the forward left corner of the cargo box. Remove the panel to check and add oil.



Oil Tank Access Panel

Cargo Box Access Panel

The cargo box access panel is located on the floor of the cargo box. Remove the panel to access the spark plugs and air filter.



Cargo Box Access Panel

FEATURES AND CONTROLS

Fuel Cap

The fuel tank filler cap is located on the right-hand side of the vehicle near the passenger seat. When refueling, always use either leaded or unleaded gasoline with a minimum pump octane number of 87 R+M/2 octane. *Do not use fuel with ethanol content greater than 10 percent, such as E-85 fuel.*

Remove flammable material containers from the box before filling.



Cab Nets

All RZR models are equipped with cab nets, which may differ slightly in appearance from those shown.

Riding in this vehicle without using the cab nets increases the risk of serious injury or death in the event of an accident or overturn. Cab nets must be used by operator and passengers at all times. Make sure all latches are secure before operating the vehicle.

Always inspect cab nets for tightness, wear and damage before each use of the vehicle. Use the strap adjusters to tighten any loose straps. Promptly replace worn or damaged cab nets with new cab nets, available from your authorized POLARIS dealer.

Cab Net Latches



FEATURES AND CONTROLS

Seat Belts

This POLARIS vehicle is equipped with three-point lap and diagonal seat belts for all riders. Always make sure the seat belts are secured for the operator and all passengers before riding.

To wear the seat belt properly, follow this procedure:

1. Pull the seat belt latch downward and across your chest toward the buckle at the inner edge of the seat. The belt should fit snugly across your hips and diagonally across your chest. Make sure the belt is not twisted.
2. Push the latch plate into the buckle until it clicks.
3. Release the strap, it will self-tighten.
4. Press the red release latch on the buckle to release the seat belt.

Seat Belt Inspection

Inspect all seat belts for proper operation before each use of the vehicle.

1. Push the latch plate into the buckle until it clicks. The latch plate must slide smoothly into the buckle. A click indicates that it's securely latched.
2. Push the red release latch in the middle of the buckle to make sure it releases freely.
3. Pull each seat belt completely out and inspect the full length for any damage, including cuts, wear, fraying or stiffness. If any damage is found, or if the seat belt does not operate properly, have the seat belt system checked and/or replaced by an authorized POLARIS dealer.
4. To clean dirt or debris from the seat belts, sponge the straps with mild soap and water. Do not use bleach, dye or household detergents. Rinse the entire length of the belt webbing. Use a garden hose to flush out the retractor and latch housings regularly.

FEATURES AND CONTROLS

Gear Selector

P: Park

R: Reverse

N: Neutral

L: Low Gear

H: High Gear

To change gears, stop the vehicle, and with the engine idling, move the lever to the desired gear. Do not attempt to shift gears with engine speed above idle or while the vehicle is moving.



Gear Selector

Tip: Maintaining shift linkage adjustment is important to assure proper transmission function. See your dealer if you experience any shifting problems.

NOTICE: Do not attempt to shift the transmission while the vehicle is moving or damage to the transmission could result. Always shift when the vehicle is stationary and the engine is at idle.

Using Low Range

Always shift into low gear for any of the following conditions.

- Operating in rough terrain or over obstacles
- Loading the vehicle onto a trailer
- Towing heavy loads

FEATURES AND CONTROLS

Brake Pedal

Depress the brake pedal to slow or stop the vehicle. Apply the brakes while starting the engine.

Throttle Pedal

Push the pedal down to increase engine speed. Spring pressure returns the pedal to the rest position when released. Always check that the throttle pedal returns normally before starting the engine.



Brake Pedal

Throttle Pedal

Rollover Protective Structure (ROPS)

The Rollover Protective Structure (ROPS) on this vehicle meets OSHA 1928.53 rollover performance requirements. Always have your authorized POLARIS dealer thoroughly inspect the ROPS if it ever becomes damaged in any way.

No device can assure occupant protection in the event of a rollover.

Always follow all safe operating practices outlined in this manual to avoid vehicle rollover.

WARNING! Vehicle rollover could cause severe injury or death. Always avoid operating in a manner that could result in vehicle rollover.

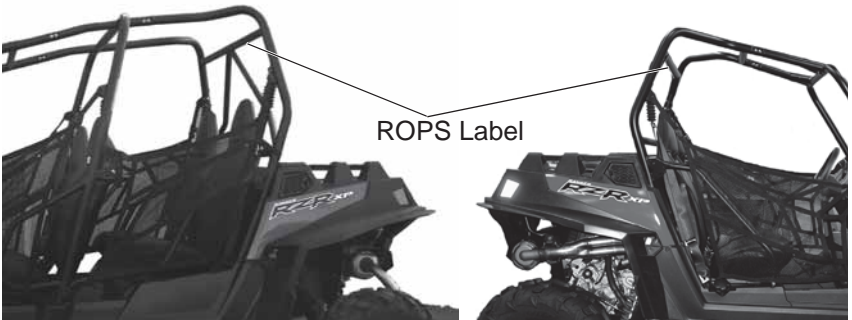

FEATURES AND CONTROLS

All Wheel Drive (AWD) System

The All Wheel Drive system is controlled by the AWD switch. When the switch is on 2X4, the vehicle is in two-wheel drive at all times. When the switch is on AWD, the vehicle is in all wheel drive and the 4X4 indicator in the instrument cluster will be on.

When in AWD, the demand drive unit will automatically engage any time the rear wheels lose traction. When the rear wheels regain traction, the demand drive unit will automatically disengage.

There is no limit to the length of time the vehicle may remain in AWD.

Engaging AWD

The AWD switch may be turned on or off while the vehicle is moving. Initially, the vehicle's electronic system will not enable the AWD until the engine RPM is below 3100. Once enabled, the AWD remains enabled until the AWD switch is turned off. If the switch is turned off while the demand drive unit is moving, it will not disengage until the rear wheels regain traction.

Engage the AWD switch before getting into conditions where front wheel drive may be needed. If the rear wheels are spinning, release the throttle before switching to AWD.

NOTICE: Switching to AWD while the rear wheels are spinning or slipping may cause severe drive shaft and gearcase damage. Always switch to AWD while the rear wheels have traction or are at rest.

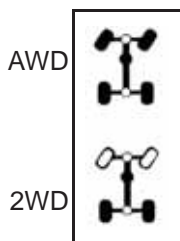

FEATURES AND CONTROLS

Instrument Cluster

NOTICE: High water pressure may damage components. Wash the vehicle by hand or with a garden hose using mild soap.

Certain products, including insect repellents and chemicals, will damage the speedometer lens and other plastic surfaces. Do not use alcohol to clean the instrument cluster. Do not allow insect sprays to contact the lens. Immediately clean off any gasoline that splashes on the instrument cluster.

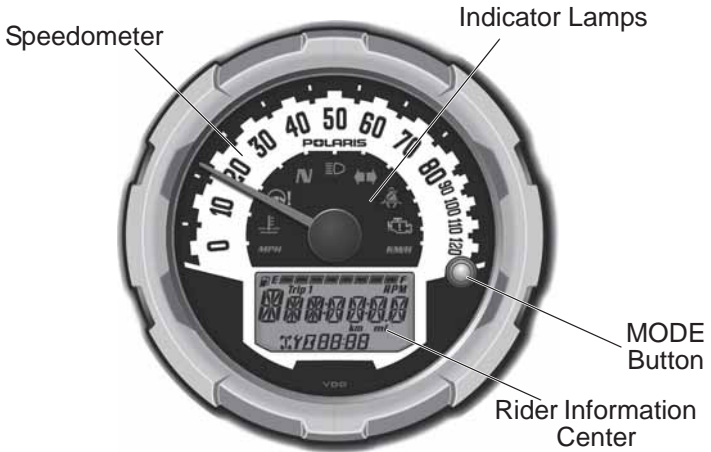

Speedometer

The speedometer displays vehicle speed in either miles per hour (MPH) or kilometers per hour (km/h). See page 45.







Mode Button

Use the MODE button to toggle through mode options. See page 45 for operation of the modes.

FEATURES AND CONTROLS

Instrument Cluster

Indicator Lamps

Lamp	Indicates	Condition
	Vehicle Speed	When standard mode is selected, speed displays in miles per hour.
		When metric mode is selected, speed displays in kilometers per hour.
	Over Temperature	This lamp illuminates to indicate an overheated engine. If the indicator flashes, the overheating condition remains, and the system will automatically reduce engine power.
	Neutral	This lamp illuminates when the transmission is in neutral and the ignition key is in the ON position.
	High Beam	This lamp illuminates when the headlamp switch is set to high beam.
	Helmet/Seat Belt	This lamp flashes for several seconds when the key is turned to the ON position. The lamp is a reminder to the operator to ensure all riders are wearing helmets and seat belts before operating.
	Check Engine	This indicator appears if an EFI-related fault occurs. Do not operate the vehicle if this warning appears. Serious engine damage could result. See your dealer.

FEATURES AND CONTROLS

Instrument Cluster

Rider Information Center

The rider information center is located in the instrument cluster. All segments will light up for one second at start-up. If the instrument cluster fails to illuminate, a battery over-voltage may have occurred and the instrument cluster may have shut off to protect the electronic speedometer. If this occurs, take the vehicle to your POLARIS dealer for proper diagnosis.

The information center is set to display standard units of measurement and a 12-hour clock at the factory. To change to metric and/or a 24-hour clock, see page 46.

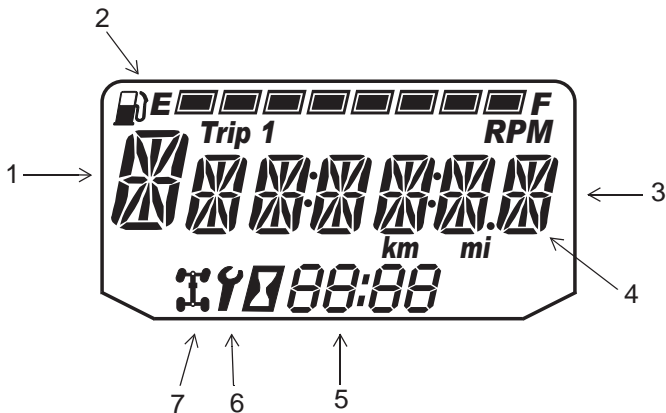

- 1. Gear Indicator** - This indicator displays gear shifter position.
 - H = High Gear
 - L = Low Gear
 - N = Neutral
 - R = Reverse Gear
 - P = Park
 - = Gear Signal Error (or shifter between gears)

FEATURES AND CONTROLS

Instrument Cluster

Rider Information Center

2. **Fuel Gauge** - The segments of the fuel gauge show the level of fuel in the fuel tank. When the last segment clears, a low fuel warning is activated. All segments including the fuel icon will flash. Refuel immediately.

Tip: If the fuel icon fails to display, an open or short circuit has occurred in the fuel sensor circuit. See your dealer.

3. **Information Display Area** - This area displays odometer, trip meter, engine hour meter and programmable service hour interval.
4. **Under / Over Voltage** - This warning usually indicates that the vehicle is operating at an RPM too low to keep the battery charged. It may also occur when the engine is at idle and high electrical load (lights, cooling fan, accessories) is applied. Drive at a higher RPM or recharge the battery to clear the warning.
5. **Clock** - The clock displays time in a 12-hour or 24-hour format. See page 46 for resetting instructions.
6. **Service Indicator** - A flashing wrench symbol alerts the operator that the preset service interval has been reached. The vehicle should be brought to your dealer for scheduled maintenance. See page 46 for resetting instructions.
7. **4X4 Indicator** - This indicator illuminates when the 4X4 system is engaged (switch is on 4X4).

FEATURES AND CONTROLS

Instrument Cluster

Rider Information Center

Use the MODE button to toggle through the information area options.

Display Units (Standard/Metric)

The display can be changed to show either standard or metric units of measurement for each of the following settings.

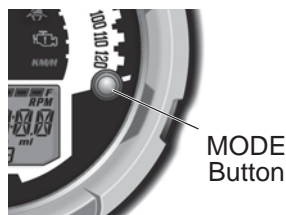

Tip: To exit the set-up mode, turn the key off. Wait 5 seconds, then turn the key on. The gauge display the mode that was displayed prior to setting the units.

	Standard Display	Metric Display
Distance	Miles	Kilometers
Fuel	U.S. Gallons	Liters, Imperial Gallons
Temperature	Fahrenheit	Celsius
Time	12-Hour Clock	24-Hour Clock

1. Turn the key to the OFF position.
2. Press and *hold* the MODE button while turning the key to the ON position.
3. When the display flashes the distance setting, tap the MODE button to advance to the desired setting.
4. Press and *hold* the MODE button to save the setting and advance to the next display option.
5. Repeat the procedure to change remaining display settings.

FEATURES AND CONTROLS

Instrument Cluster

Rider Information Center

Clock Mode

Tip: The clock must be reset any time the battery has been disconnected or discharged.

1. Turn the key to the ON position. Use the MODE button to toggle to the odometer display.
2. Press and *hold* the MODE button until the hour segment flashes. Release the button.
3. With the segment flashing, tap the MODE button to advance to the desired setting.
4. Press and *hold* the MODE button until the next segment flashes. Release the button.
5. Repeat steps 3-4 twice to set the 10-minute and 1-minute segments. After completing the 1-minute segment, step 4 will save the new settings and exit the clock mode.
6. Turn the key to the OFF position.

FEATURES AND CONTROLS

Instrument Cluster

Rider Information Center

Odometer Mode

The odometer records and displays the distance traveled by the vehicle.

Trip Meter Mode

The trip meter records the distance traveled by the vehicle if reset before each trip. To reset, select the trip meter mode. Press and hold the MODE button until the meter resets to zero. In the Rider Information Center, the trip meter display contains a decimal point, but the odometer displays without a decimal point.

Hour Meter Mode

This mode logs the total hours the engine has been in operation.

Engine Temperature Mode

This mode displays current temperature of the coolant.

Tachometer Mode

The engine RPM is displayed digitally.

Tip: Small fluctuations in the RPM from day to day may be normal because of changes in humidity, temperature and elevation.

FEATURES AND CONTROLS

Instrument Cluster

Rider Information Center

Programmable Service Interval

When the hours of engine operation equal the programmed service interval setting, the wrench icon will flash for 5 seconds each time the engine is started. When this feature is enabled, it provides a convenient reminder to perform routine maintenance. The service interval is programmed at 50 hours at the factory. Use the following procedure to change the service interval.

1. Press the MODE button until remaining service hours display.
2. Press and hold the MODE button.
3. When the service hours flash, press and release the MODE button to advance the hours to the desired setting (including OFF). Press and hold the MODE button to set the new service hour interval.

Diagnostic Display Mode

The EFI diagnostic display mode is for informational purposes only. Please see your POLARIS dealer for all major repairs.

The diagnostic mode is accessible only when the check engine warning indicator activates after the key has been turned on. Leave the key on if you want to view the active code (failure code).

The diagnostic mode becomes inaccessible if the key is turned off and on and the warning indicator is no longer active. This allows the determination of persistent as well as intermittent faults.

Inactive codes are stored in the history of the unit.

FEATURES AND CONTROLS

Instrument Cluster

Rider Information Center

Engine Error Codes

The error screen displays only when the CHECK ENGINE light is on or when it goes on and off during one ignition cycle. Error codes are not stored. When the key is turned OFF, the code and message is lost, but will reappear if the fault reoccurs after restarting the engine.

If the CHECK ENGINE light illuminates, retrieve the error codes from the display.

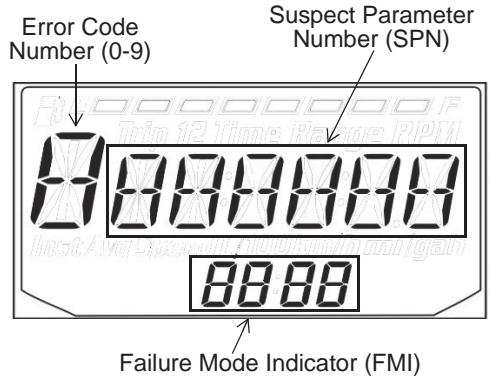

1. If the error codes are not displayed, use the MODE button to toggle until “Ck ENG” displays on the main line of the display.
2. Press and hold the MODE button to enter the diagnostics code menu.
3. Record the three numbers displayed in the gear position, clock and odometer displays.
4. Press the MODE button to advance to the next error code.
5. Press and hold the MODE button to exit the diagnostics code menu.
6. See an authorized POLARIS dealer for code details and diagnosis.

OPERATION

WARNING

Failure to operate the vehicle properly can result in a collision, loss of control, accident or overturn, which may result in serious injury or death. Read and understand all safety warnings outlined in the safety section of this owner's manual.

Vehicle Break-in Period

The break-in period for your new POLARIS vehicle is the first 25 hours of operation, or the time it takes to use the first two tanks full of gasoline. No single action on your part is as important as a proper break-in period. Careful treatment of a new engine and drive components will result in more efficient performance and longer life for these components. Perform the following procedures carefully.

NOTICE: Excessive heat build-up during the first three hours of operation will damage close-fitted engine parts and drive components. Do not operate at full throttle or high speeds during the first three hours of use.

Use of any oils other than those recommended by POLARIS may cause serious engine damage. We recommend the use of POLARIS Premium 4 Synthetic Oil for your 4-cycle engine.

Vehicle Break-in Period

Engine and Drivetrain Break-in

1. Fill the fuel tank with gasoline. See page 36. Always exercise extreme caution whenever handling gasoline.
2. Check the oil level. See page 77. Add the recommended oil as needed to maintain the oil level in the safe operating range.
3. Complete the New Operator Driving Procedures outlined on pages 56-57.
4. Avoid aggressive use of the brakes. See Brake System Break-in on page 51.
5. Vary throttle positions. Do not operate at sustained idle.
6. Perform regular checks on fluid levels, controls and areas outlined on the daily pre-ride inspection checklist. See page 52.
7. Carry only light loads.
8. During the break-in period, change both the oil and the filter at 25 hours or one month.

Brake System Break-in

Apply only moderate braking force for the first 50 stops. Aggressive or overly forceful braking when the brake system is new could damage brake pads and rotors.

PVT Break-in (Clutches/Belt)

A proper break-in of the clutches and drive belt will ensure a longer life and better performance. Break in the clutches and belt by operating at slower speeds during the break-in period as recommended. Carry only light loads. Avoid aggressive acceleration and high speed operation during the break-in period.

If a belt fails, always clean any debris from the duct and from the engine compartment.

OPERATION

Pre-Ride Inspection

Failure to inspect and verify that the vehicle is in safe operating condition before operating increases the risk of an accident. Always inspect the vehicle before each use to make sure it's in safe operating condition.

Item	Remarks	Page
Brake system/pedal travel	Ensure proper operation	39 99
Brake fluid	Ensure proper level	100
Front suspension	Inspect, lubricate if necessary	74
Rear suspension	Inspect, lubricate if necessary	74
Steering	Ensure free operation	110
Tires	Inspect condition and pressure	20 105
Wheels/fasteners	Inspect, ensure fastener tightness	105
Frame nuts, bolts, fasteners	Inspect, ensure tightness	-
Fuel and oil	Ensure proper levels	44 77
Coolant level	Ensure proper level	89-90
Coolant hoses	Inspect for leaks	-
Throttle	Ensure proper operation	98
Indicator lights/switches	Ensure proper operation	30-31
Engine intake pre-filter	Inspect, clean	94
PVT intake pre-filter	Inspect, clean	94
Headlamp	Check operation	-
Brake light/tail lamp	Check operation, apply POLARIS dielectric grease when lamp is replaced	107
Seat Latches	Push down on both seat backs to ensure the latches are secure	32
Seat Belts	Check length of belt for damage, check latches for proper operation	37
Cab Nets	Check for wear or damage, ensure proper installation	36

Safe Operation Practices

1. Visit the Recreational Off-Highway Vehicle Association web site (rohva.org) and take the free on-line training course. Complete the New Operator Driving Procedures outlined on pages 56-57.
2. Do not allow anyone under 16 years of age or without a valid driver's license to operate this vehicle.
3. Never operate with a passenger under the age of 12. Never carry more one passenger in a 2-seat vehicle. Never carry more than three passengers in a 4-seat vehicle. Never allow a passenger to ride in the cargo box.
4. Engine exhaust fumes are poisonous. Never start the engine or let it run in an enclosed area.
5. Never operate with accessories not approved by POLARIS for use on this vehicle.
6. Operate this vehicle off-road only. Never operate the vehicle on pavement or on any public street, road or highway, including dirt and gravel roads.
7. Drive in a manner appropriate for your skills and operating conditions. Never operate at excessive speeds. Never attempt wheelies, jumps, or other stunts. Keep both hands on the steering wheel during operation.
8. Never consume alcohol or drugs before or while operating this vehicle.
9. Always use the size and type of tires specified for your vehicle. Always maintain proper tire pressure.
10. Never operate a damaged vehicle. After any overturn or accident, have a qualified service dealer inspect the entire machine for possible damage.
11. Never operate the vehicle on a frozen body of water unless you have first verified that the ice is sufficiently thick to support the weight and moving force of the vehicle, you and your passenger, and your cargo, together with any other vehicles in your party.
12. Do not touch hot exhaust system components. Always keep combustible materials away from the exhaust system.
13. Always remove the ignition key when the vehicle is not in use to prevent unauthorized use.

OPERATION

Starting the Engine

1. Position the vehicle on a level surface outdoors or in a well-ventilated area.
2. Sit in the driver's seat and fasten the seat belt. Secure the cab nets.
3. Place the transmission in PARK.
4. Apply the brakes. Do not press the throttle pedal while starting the engine.
5. Turn the ignition key past the ON/RUN position to START. Engage the starter for a maximum of five seconds. Release the key when the engine starts.
6. If the engine does not start within five seconds, return the ignition switch to the OFF position and wait five seconds. Repeat steps 5 and 6 until the engine starts.
7. Vary the engine RPM slightly with the throttle to aid in warm up until the engine idles smoothly.

NOTICE: Operating the vehicle immediately after starting could cause engine damage. Allow the engine to warm up for several minutes before operating the vehicle.

Stopping the Engine

1. Release the throttle pedal completely and brake to a complete stop.
2. Place the transmission in PARK.
3. Turn the engine off.

Braking

1. Release the throttle pedal completely. (When the throttle pedal is released completely and engine speed slows to near idle, the vehicle has no engine braking.)
2. Press on the brake pedal evenly and firmly. Practice starting and stopping (using the brakes) until you're familiar with the controls.

Parking the Vehicle

1. Stop the vehicle on a level surface. When parking inside a garage or other structure, be sure that the structure is well ventilated and that the vehicle is not close to any source of flame or sparks, including any appliance with pilot lights.
2. Place the transmission in PARK.
3. Turn the engine off.
4. Remove the ignition key to prevent unauthorized use.

Know Your Riding Area/Tread Lightly

Familiarize yourself with all laws and regulations concerning the operation of this vehicle in your area. Respect the environment in which you ride your vehicle. Find out where the designated riding areas are by contacting your POLARIS dealer, a local riding club, or local officials.

Help keep our trails open for recreational vehicle use. As an off-road enthusiast, you represent the sport and can set a good example (or a poor example) for others to follow. Tread lightly. Operate with respect for the terrain, avoid littering, and always stay on the designated trails.

Trail Etiquette

Always practice good etiquette when riding. Allow a safe distance between your vehicle and other vehicles operating in the same area. Communicate to oncoming operators by signaling the number of vehicles in your group. When stopping, move your vehicle to the edge of the trail as far as possible to allow others to pass safely.

OPERATION

New Operator Driving Procedures



1. Read and understand the owner's manual and all warning and instruction labels before operating this vehicle.
2. Visit the Recreational Off-Highway Vehicle Association web site (rohva.org) and take the free on-line training course.
3. Perform the pre-ride inspection. See page 52.
4. Wear an approved helmet that fits properly and eye protection (goggles or face shield).
5. Do not carry a passenger until you have at least two hours of driving experience with this vehicle.
6. Do not carry cargo during this period.
7. Select an open area that allows room to familiarize yourself with vehicle operation and handling.
8. Sit in the driver's seat and fasten the seat belt.
9. Always use the cab nets while riding in this vehicle.
10. Place the transmission in PARK.
11. Start the engine.

New Operator Driving Procedures

12. Apply the brakes and shift into low gear.
13. Check your surroundings and determine your path of travel.
14. Keeping both hands on the steering wheel, slowly release the brakes and depress the throttle with your right foot to begin driving.
15. Drive slowly at first. On level surfaces, practice starting, stopping, turning, maneuvering, using the throttle and brakes and driving in reverse. Learn how the vehicle handles when making both left and right turns at a slow speed.
16. Increase speed only after mastering all maneuvers at a slow speed.
17. After you become skilled at making turns and begin to operate at faster speeds, follow these precautions:
 - Avoid sharp turns.
 - Never turn while applying heavy throttle.
 - Never make abrupt steering maneuvers.
 - Operate at speeds appropriate for your skills, the conditions and the terrain.
 - DO NOT do power slides, “donuts”, jumps or other driving stunts.

OPERATION

Driving with Passengers

1. Complete the New Operator Driving Procedures outlined on pages 56-57.
2. Perform the pre-ride inspection. See page 52.
3. Do not carry more than one passenger in a 2-seat vehicle. Do not carry more than three passengers in a 4-seat vehicle. Additional passengers can affect the operator's ability to steer and operate the controls.
4. Make sure all passengers are at least 12 years of age and are tall enough to comfortably and safely sit in a passenger seat, put both feet on the floor and grasp the passenger hand hold or grab bar.
5. Make sure all passengers are wearing appropriate riding gear, including an approved helmet and eye protection. See page 8.
6. Make sure all passengers secure their seat belts.
7. Make sure all cab nets are properly secured.
8. Allow a passenger to ride only in a passenger seat.
9. Slow down. Always travel at a speed appropriate for your skills, your passengers' skills and operating conditions. Avoid unexpected or aggressive maneuvers that could cause discomfort or injury to a passenger.
10. Vehicle handling may change with passengers and/or cargo on board. Allow more time and distance for braking.
11. Always follow all operating guidelines as outlined on safety labels and in this manual.

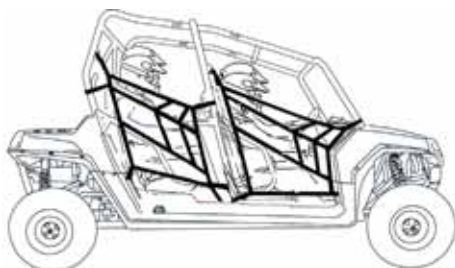

Driving on Slippery Surfaces

⚠ WARNING

Skidding or sliding can cause loss of control or overturn (if tires regain traction unexpectedly). When operating on slippery surfaces such as ice or loose gravel, reduce speed and use extra caution to reduce the chance of skidding or sliding out of control. Do not operate on excessively slippery surfaces.

When driving on slippery surfaces such as wet trails, loose gravel, or ice, be alert for the possibility of skidding and sliding.

Follow these precautions when encountering slippery conditions:

1. Slow down before entering slippery areas.
2. Maintain a high level of alertness, reading the trail and avoiding quick, sharp turns, which can cause skids.
3. Engage all-wheel drive before wheels begin to lose traction.

NOTICE: Severe damage to the drive train may occur if the AWD is engaged while the wheels are spinning. Always allow the wheels to stop spinning before engaging AWD.

4. Correct a skid by turning the steering wheel in the direction of the skid. *Never apply the brakes during a skid.*

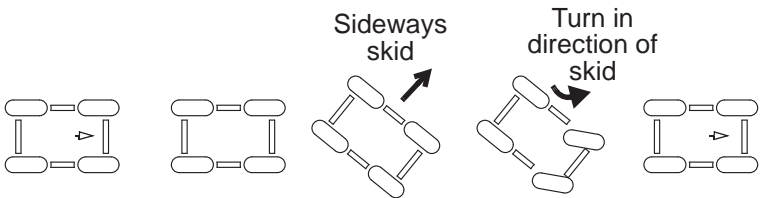

OPERATION

Driving Uphill

Whenever traveling uphill, follow these precautions:

1. Always check the terrain carefully before ascending a hill.
2. Avoid steep hills (15° maximum). If ascending a steeper grade is unavoidable, engage all-wheel drive before ascending.
3. Drive straight uphill.
4. Never climb hills with excessively slippery or loose surfaces.
5. Proceed at a steady rate of speed and throttle opening. Never open the throttle suddenly.
6. Avoid unnecessary changes in speed or direction.
7. Never go over the crest of a hill at high speed. An obstacle, a sharp drop, or another vehicle or person could be on the other side of the hill.
8. If the vehicle stalls while climbing a hill, apply the brakes. Place the transmission in reverse and slowly allow the vehicle to roll straight downhill while applying light brake pressure to control speed.

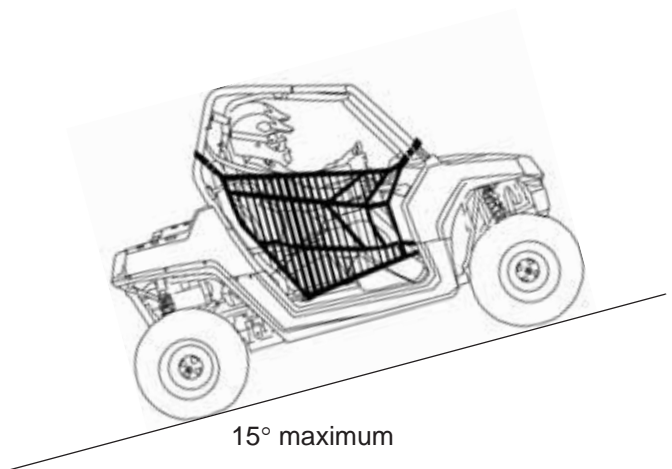

Driving on a Sidehill (Sidehilling)

Driving on a sidehill is not recommended. Improper procedure could cause loss of control or overturn. Avoid crossing the side of any hill unless absolutely necessary.

If crossing a hill is *unavoidable*, follow these precautions:

1. Engage all-wheel drive.
2. Drive slowly and use extreme caution.
3. If the vehicle begins to overturn, or if it feels as if it may overturn, *immediately* turn downhill.
4. Avoid obstacles and changes in terrain that may lower or raise one side of the vehicle or cause the vehicle to slide.
5. If the vehicle begins to slide downhill, immediately turn downhill to stop the slide, or stop the vehicle and maneuver slowly and carefully until the vehicle can be driven straight downhill.

Driving Downhill

Whenever descending a hill, follow these precautions:

1. Avoid steep hills (15° maximum).
2. Slow down. Never travel down a hill at high speed.
3. Always check the terrain carefully before descending a hill.
4. Always descend a hill with the transmission in forward gear. *Never descend a hill with the transmission in neutral.*
5. Avoid traveling down a hill at an angle, which would cause the vehicle to lean sharply to one side. Travel straight downhill.
6. Apply the brakes *lightly* to aid in slowing.

OPERATION

Driving Through Water

Your vehicle can operate through water with a maximum recommended depth equal to floor level. Follow these precautions when operating through water:

1. Determine water depth and current before entering water.
2. Choose a crossing where the water level is lowest and where both banks have gradual inclines. Never operate in water that exceeds the maximum recommended depth.

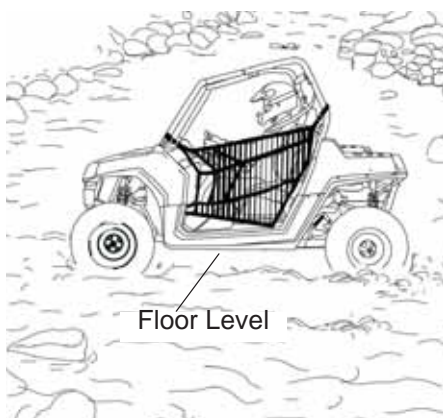

WARNING! The large tires on your vehicle may cause the vehicle to float in deep or fast-flowing water, which could result in loss of traction, loss of control, overturn or accident.

3. Wet brakes may have reduced stopping ability. After leaving water, test the brakes. Apply them lightly several times while driving slowly. The friction will help dry out the pads.

NOTICE: Major engine damage can result if the vehicle is not thoroughly inspected after operation in water. Perform the services outlined in the maintenance chart. See page 69. Give special attention to engine oil, transmission oil, demand drive fluid, rear gearcase oil, and all grease fittings.

If your vehicle becomes immersed or is operated in water that exceeds the floor level, take it to your dealer for service *before starting the engine*. If it's impossible to bring the vehicle to your dealer before starting the engine, perform the service outlined on page 109, and take the vehicle to your dealer at the first opportunity.

Driving Over Obstacles

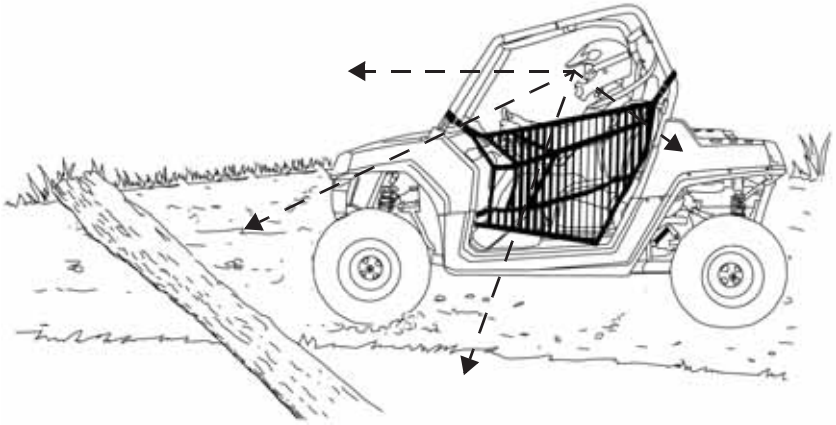

Follow these precautions when operating over obstacles:

1. Always check for obstacles before operating in a new area.
2. Look ahead and learn to read the terrain. Be constantly alert for hazards such as logs, rocks and low hanging branches.
3. Travel slowly and use extra caution when operating on unfamiliar terrain. Not all obstacles are immediately visible.
4. Avoid operating over large obstacles such as rocks and fallen trees. If unavoidable, use extreme caution and operate slowly.
5. Always have all passengers dismount and move away from the vehicle before operating over an obstacle that could cause an overturn.

OPERATION

Driving in Reverse

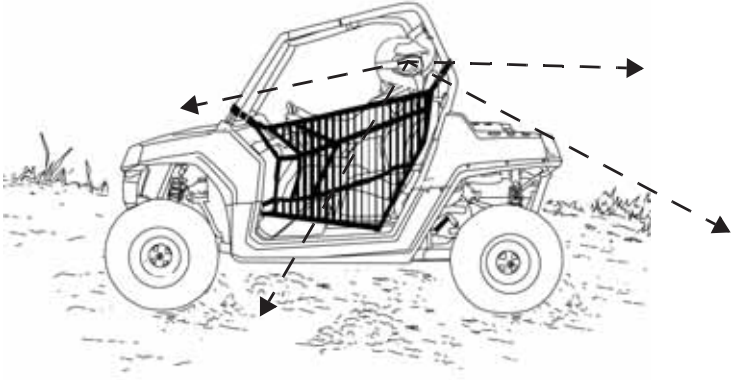

Follow these precautions when operating in reverse:

1. Always check for obstacles or people behind the vehicle.
2. Apply the throttle *lightly*. Never open the throttle suddenly.
3. Back slowly.
4. Apply the brakes *lightly* for stopping.
5. Avoid making sharp turns.

Parking on an Incline

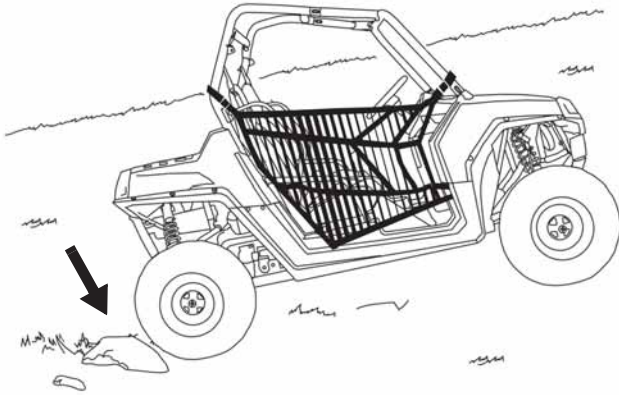

A rolling vehicle can result in serious injury. Avoid parking on an incline. If parking on an incline is *unavoidable*, follow these precautions:

1. Place the transmission in PARK.
2. Turn the engine off.
3. Block the rear wheels on the downhill side, or park the vehicle in a sidehill position instead.

OPERATION

Hauling Cargo

⚠ WARNING

Overloading the vehicle or carrying cargo improperly can alter vehicle handling and may cause loss of control or brake instability. Always follow these precautions when hauling cargo:

Never exceed the stated load capacity for this vehicle.

REDUCE SPEED AND ALLOW GREATER DISTANCES FOR BRAKING WHEN HAULING CARGO.

NEVER EXCEED THE MAXIMUM WEIGHT CAPACITY of the vehicle. When determining the weight you are adding to the vehicle, include the weight of the operator, passengers, accessories and loads in the rack or box. The combined weight of these items must not exceed the maximum weight capacity.

Always load the cargo box with the load as far forward and as low as possible.

When operating over rough or hilly terrain, reduce speed and cargo to maintain stable driving conditions.

Always operate the vehicle with extreme care when hauling cargo. Slow down and drive in the lowest gear available.

SECURE ALL LOADS BEFORE OPERATING. Unsecured loads can create unstable operating conditions, which could result in loss of control of the vehicle.

OPERATE ONLY WITH STABLE AND SAFELY ARRANGED LOADS. When handling off-centered loads that cannot be centered, securely fasten the load and operate with extra caution. \

HEAVY LOADS CAN CAUSE BRAKING AND CONTROL PROBLEMS. Use extreme caution when applying brakes with a loaded vehicle. Avoid terrain or situations that may require backing downhill.

USE EXTREME CAUTION when operating with loads that extend over the rack sides. Stability and maneuverability may be adversely affected, causing the vehicle to overturn.

DO NOT TRAVEL FASTER THAN THE RECOMMENDED SPEEDS. Vehicle should never exceed 10 MPH (16 km/h) while cornering or while ascending or descending a hill.

Carrying a passenger in the cargo box could result in a fall from the vehicle or contact with moving components. Never allow a passenger to ride in the cargo box. A passenger must always be seated in a passenger seat with seat belt secured.



Hauling Cargo

Your POLARIS vehicle has been designed to carry a specific capacity. Reduce speed and allow a greater distance for braking when carrying cargo.

Loads should be centered and carried as low as possible in the box. For stability on rough or hilly terrain, reduce both speed and cargo. Exercise caution if the cargo load extends over the side of the box.

Always read and understand the load distribution warnings listed on warning labels and in this manual. Never exceed the maximum capacities specified for your vehicle. See page 120.

Belt Life

To extend belt life, use low gear when hauling a heavy load at less than 7 MPH (11 km/h) for extended periods and when operating uphill at a slow speed.

EMISSION CONTROL SYSTEMS

Noise Emission Control System

Do not modify the engine, intake or exhaust components, as doing so may affect compliance with U.S.A. EPA noise control requirements (40 CFR 205) and local noise level requirements.

Operation on Public Lands in the U.S.A.

Your POLARIS vehicle has a spark arrester that was tested and qualified to be in accordance with the USFS standard 5100-1C. Federal law requires that this spark arrester be installed and functional when the vehicle is operated on public lands.

Operation of off-road vehicles on public lands in the U.S.A. is regulated by 43 CFR 420. Violations are subject to monetary penalties. Federal regulations can be viewed online at www.gpoaccess.gov/ecfr/.

Crankcase Emission Control System

This engine is equipped with a closed crankcase system. Blow-by gases are forced back to the combustion chamber by the intake system. All exhaust gases exit through the exhaust system.

Exhaust Emission Control System

Exhaust emissions are controlled by engine design. An electronic fuel injection (EFI) system controls fuel delivery. The engine and EFI components are set at the factory for optimal performance and are not adjustable.

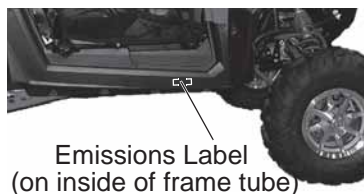

The emissions label is located on the inside of the lower right frame tube (below front passenger foot area).

Electromagnetic Interference

This spark ignition system complies with Canadian ICES-002.

This vehicle complies with the EMC requirements of European directives 97/24/EC and 2004/108/EC.

Non-ionizing Radiation: This vehicle emits some electromagnetic energy. People with active or non-active implantable medical devices (such as heart monitoring or controlling devices) should review the limitations of their device and the applicable electromagnetic standards and directives that apply to this vehicle.

Periodic Maintenance Chart

Careful periodic maintenance will help keep your vehicle in the safest, most reliable condition. Inspection, adjustment and lubrication of important components are explained in the periodic maintenance chart.

Inspect, clean, lubricate, adjust and replace parts as necessary. When inspection reveals the need for replacement parts, use genuine POLARIS parts available from your POLARIS dealer.

Record maintenance and service in the Maintenance Log beginning on page 137.

Service and adjustments are important for proper vehicle operation. If you're not familiar with safe service and adjustment procedures, have a qualified dealer perform these operations.

Maintenance intervals in the following chart are based upon average riding conditions and an average vehicle speed of approximately 10 MPH (16 km/h). Vehicles subjected to severe use must be inspected and serviced more frequently.

Severe Use Definition

- Frequent immersion in mud, water or sand
- Racing or race-style high RPM use
- Prolonged low speed, heavy load operation
- Extended idle
- Frequent short trip operation in cold weather (engine frequently does not operate long enough to reach full operating temperature)

Pay special attention to the oil level. A rise in oil level during cold weather can indicate contaminants collecting in the oil sump or crankcase. Change oil immediately if the oil level begins to rise. Monitor the oil level, and if it continues to rise, discontinue use and determine the cause or see your dealer.

MAINTENANCE

Periodic Maintenance Chart

Maintenance Chart Key

▶ Perform these operations more often for vehicles subjected to severe use.

E Emission-related service (Failure to conduct this maintenance will not void the emissions warranty but may affect emissions.)

■ Have an authorized POLARIS dealer perform these services.

WARNING! Improperly performing the procedures marked with a ■ could result in component failure and lead to serious injury or death. Have an authorized POLARIS dealer perform these services.

MAINTENANCE

Periodic Maintenance Chart

Perform all services at whichever maintenance interval is reached first.

Item	Maintenance Interval (whichever comes first)			Remarks
	Hours	Calendar	Miles (Km)	
Steering	-	Pre-Ride	-	Make adjustments as needed. See Pre-Ride Checklist on page 52.
Front suspension	-	Pre-Ride	-	
Rear suspension	-	Pre-Ride	-	
Tires	-	Pre-Ride	-	
Brake fluid level	-	Pre-Ride	-	
Brake pedal travel				
Brake system	-	Pre-Ride	-	
Wheels/fasteners	-	Pre-Ride	-	
Frame fasteners	-	Pre-Ride	-	
Engine oil level	-	Pre-Ride	-	
E Engine intake pre-filter	-	Daily	-	Inspect; clean often
PVT intake pre-filter	-	Daily	-	Inspect; clean often
Coolant	-	Daily	-	Check coolant level
Headlight/taillight	-	Daily	-	Check operation; apply dielectric grease if replacing
▶ ■ Brake pad wear	10 H	Monthly	100 (160)	Inspect periodically
▶ Engine oil change (break-in)	25 H	1 M	-	Perform a break-in oil and filter change at one month
▶ E Air filter	25 H	Monthly	250 (400)	Inspect; replace as needed
Battery	25 H	Monthly	250 (400)	Check terminals; clean; test
▶ Front gearcase (demand drive) fluid	25 H	Monthly	250 (400)	Inspect level; add if needed
▶ Transmission (main gearcase) oil	25 H	Monthly	250 (400)	Inspect level; add if needed
▶ E Engine breather filter (if equipped)	25 H	Monthly	150 (250)	Inspect; replace if necessary

▶ Perform these procedures more often for vehicles subjected to severe use.

E Emission-Related Service

■ Have an authorized POLARIS dealer perform these services.

MAINTENANCE

Periodic Maintenance Chart

Item		Maintenance Interval (whichever comes first)			Remarks
		Hours	Calendar	Miles (Km)	
▶	General lubrication	50 H	3 M	500 (800)	Lubricate all fittings, pivots, cables, etc.
■ E	Throttle cable	50 H	6 M	300 (500)	Inspect; see dealer for service
E	Throttle body air intake ducts/flange	50 H	6 M	300 (500)	Inspect duct for proper sealing/air leaks
▶	Engine oil change	50 H	6 M	1000 (1600)	Perform a break-in oil change at one month
▶	Oil filter change	50 H	6 M	1000 (1600)	Replace with oil change
	Shift Linkage	50 H	6 M	500 (800)	Inspect, adjust
▶	Front Suspension	50 H	6 M	500 (800)	Lubricate
▶	Rear Suspension	50 H	6 M	500 (800)	Lubricate
	Cooling system (if applicable)	50 H	6 M	500 (800)	Inspect coolant strength seasonally; pressure test system yearly
▶	Front gearcase (demand drive) fluid	-	12 M	2500 (4000)	Change fluid
▶	Transmission (main gearcase) oil	-	12 M	2500 (4000)	Change fluid
■ E	Fuel system	100 H	12 M	1000 (1600)	Check for leaks at tank cap, lines, filter, pump, throttle body
▶ E	Spark plugs	100 H	12 M	1000 (1600)	Inspect; replace as needed, torque to specification

▶ Perform these procedures more often for vehicles subjected to severe use.

E Emission-Related Service

■ Have an authorized POLARIS dealer perform these services.

MAINTENANCE

Periodic Maintenance Chart

Item	Maintenance Interval (whichever comes first)			Remarks
	Hours	Calendar	Miles (Km)	
▶ Radiator (if equipped)	100 H	12 M	1000 (1600)	Inspect; clean external surfaces
▶ Cooling Hoses	100 H	12 M	1000 (1600)	Inspect for leaks
▶ Engine mounts	100 H	12 M	1000 (1600)	Inspect
Exhaust muffler/ pipe	100 H	12 M	1000 (1600)	Inspect
■ Ignition timing	100 H	12 M	1000 (1600)	Inspect
▶ Wiring	100 H	12 M	1000 (1600)	Inspect for wear, routing, security; apply dielectric grease to connectors subjected to water, mud, etc.
■ Clutches (drive and driven)	100 H	12 M	1000 (1600)	Inspect; clean; replace worn parts
Drive belt	100 H	12 M	1000 (1600)	Inspect; replace as needed
■ Front wheel bearings	100 H	12 M	1000 (1600)	Inspect; replace as needed
▶ Coolant	-	24 M	-	Replace coolant
■ Brake fluid	200 H	24 M	2000 (3200)	Change every two years
Spark arrester	200 H	24 M	2000 (3200)	Clean out
Valve lash	200 H	-	2000 (3200)	Check; adjust as needed
▶ Spark plugs	500 H	36 M	5000 (8000)	Replace, torque to specification
■ Toe adjustment		-		Inspect periodically; adjust when parts are replaced
Headlight aim		-		Adjust as needed

▶ Perform these procedures more often for vehicles subjected to severe use.

E Emission-Related Service

■ Have an authorized POLARIS dealer perform these services

MAINTENANCE

Lubrication Recommendations

Check and lubricate all components at the intervals outlined in the Periodic Maintenance Chart beginning on page 69, or more often under severe use, such as wet or dusty conditions. Items not listed in the chart should be lubricated at the general lubrication interval.

Item	Lube	Method
Engine Oil	PS-4 PLUS Synthetic Engine Oil	Add to proper level on dipstick. See page 77.
Brake Fluid	DOT 4	Maintain level between fill lines. See page 100.
Transmission Oil (Main Gearcase)	Premium AGL Synthetic Gearcase Lube	See page 80.
Front Gearcase Fluid (Demand Drive)	Demand Drive Plus Fluid	See page 82.
Prop Shaft	POLARIS Premium U-Joint Lube	Grease middle and rear fittings.
Front Control Arm Pivot Bushings	POLARIS Premium all Season Grease or grease conforming to NLGI No. 2	Grease 3 fittings on each side of the vehicle.
Stabilizer Bar Bushings	POLARIS Premium all Season Grease or grease conforming to NLGI No. 2	Grease 2 fittings through the skid plate access holes located directly below the seat backs.

Middle Prop Shaft
Grease Fitting



Fitting Access
(as viewed from top with
center floor panel removed)



Rear Prop Shaft
Grease Fitting

MAINTENANCE

Lubrication Recommendations

View of Driver's Side From Bottom of Vehicle

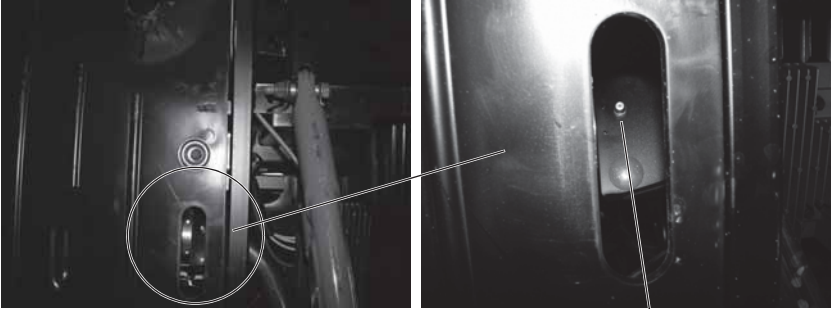

Grease Stabilizer Bar Bushings
(one on each side of vehicle)

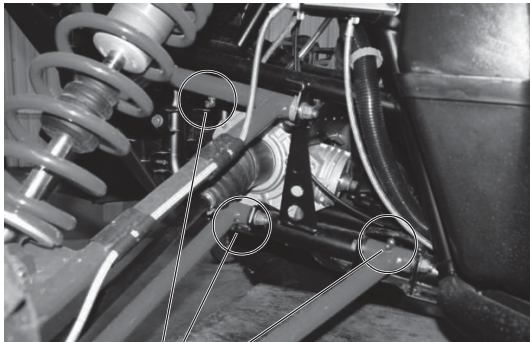

Front Control Arm Pivot
Bushings (3 per side)

MAINTENANCE

Engine Oil

Oil Recommendations

POLARIS recommends the use of POLARIS PS-4 PLUS Synthetic engine oil.

WARNING! Vehicle operation with insufficient, deteriorated, or contaminated engine oil will cause accelerated wear and may result in engine seizure, accident, and injury. Always perform the maintenance procedures as outlined in the Periodic Maintenance Chart.

Oil may need to be changed more frequently if POLARIS PS-4 PLUS Synthetic engine oil is not used. Follow the manufacturer's recommendations for ambient temperature operation. See page 124 for the part numbers of POLARIS products.

NOTICE: Mixing brands or using a non-recommended oil may cause serious engine damage. Always use the recommended oil. Never substitute or mix oil brands.

Engine Oil

Always check and change the oil at the intervals outlined in the Periodic Maintenance Chart beginning on page 69. Always use the recommended engine oil.

Oil Check

Always check the oil when the engine is cold. If the engine is hot when the oil is checked, the level will appear to be overfull.

Access the oil tank dipstick through the oil tank access panel in the left forward corner of the cargo box.

1. Position the vehicle on a level surface.
2. Place the transmission in PARK.
3. Start the engine and allow it to idle for 30 seconds.
4. Stop the engine and wait 15 seconds before removing the dipstick.
5. Open the oil tank access panel. Remove the dipstick from the oil tank. Wipe it dry with a clean cloth.
6. Reinstall the dipstick completely. Remove the dipstick and check the oil level.
7. Add the recommended oil as needed. Maintain the oil level between the minimum and maximum marks on the dipstick. Do not overfill.
8. Reinstall the dipstick.

Oil Check/Fill

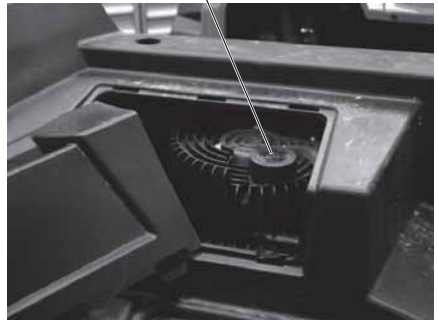

MAINTENANCE

Engine Oil

Oil and Filter Change

Always change the oil and filter at the intervals outlined in the Periodic Maintenance Chart beginning on page 69. Always change the oil filter whenever changing oil.

The oil tank drain plug is on the bottom of the oil tank. Access the drain plug through the left rear wheel well.

The crankcase drain plug is located on the bottom of the crankcase.

Access the drain plug through the access hole under the crankcase.

1. Position the vehicle on a level surface. Place the transmission in PARK.
2. Clean the areas around the oil tank and crankcase drain plugs.

CAUTION! Hot oil can cause burns to skin. Do not allow hot oil to contact skin.

3. Place a drain pan under the oil tank and remove the drain plug. Allow the oil to drain completely.
4. Place a drain pan under the engine crankcase and remove the drain plug. Allow the oil to drain completely.

Oil Tank Drain Plug



Crankcase
Drain Plug

Access
Hole

Engine Oil Oil and Filter Change

5. Locate the oil catch tool in the tool kit. Position the oil catch tool below the oil filter to catch spills when the filter is removed.
6. Using an oil filter wrench, turn the filter counter-clockwise to remove it.
7. Using a clean dry cloth, clean the filter sealing surface on the crankcase.
8. Lubricate the o-ring on the new filter with a film of fresh engine oil. Check to make sure the o-ring is in good condition.
9. Install the new filter and turn by hand until the filter gasket contacts the sealing surface, then turn and additional 1/2 turn.
10. Reinstall the oil tank and crankcase drain plugs. Torque both drain plugs to 12 ft. lbs. (16 Nm).
11. Remove the dipstick and fill the oil tank with 3.5 quarts (3.3 l) of recommended oil.
12. Start the engine and allow it to idle for 30 seconds.
13. Stop the engine and wait 15 seconds before removing the dipstick.
14. Remove the dipstick from the oil tank. Wipe it dry with a clean cloth.
15. Reinstall the dipstick completely. Remove the dipstick and check the oil level.
16. Add oil as necessary to bring the level to the upper mark on the dipstick. Do not overfill.
17. Reinstall the dipstick.
18. Dispose of used filter and oil properly.

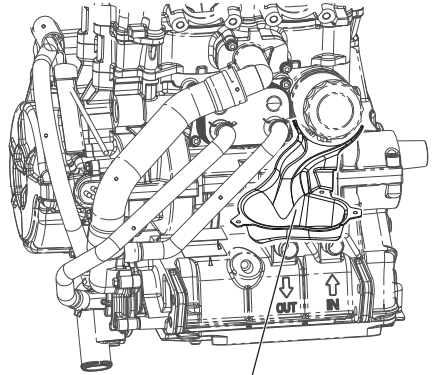

MAINTENANCE

Transmission (Main Gearcase)

Always check and change the fluid at the intervals outlined in the Periodic Maintenance Chart beginning on page 69. Refer to the Gearcase Specifications Chart on page 84 for recommended lubricants, capacities and torque specifications.

Fluid Check

The fill plug is located on the rear of the gearcase. Maintain the fluid level at the bottom of the fill plug hole.



Fill Plug

1. Position the vehicle on a level surface.
2. Remove the fill plug.
3. Check the fluid level.
4. Add the recommended fluid to the bottom of the fill plug hole. Do not overfill.
5. Reinstall the fill plug. Torque to specification.

Transmission (Main Gearcase) Fluid Change

The drain plug is located on the bottom of the gearcase. Access the drain plug through the drain hole in the skid plate.

1. Remove the fill plug.
2. Place a drain pan under the drain plug.
3. Remove the drain plug. Allow the fluid to drain completely.
4. Clean the drain plug.
5. Reinstall the drain plug with a new o-ring. Torque to specification.
6. Add the recommended fluid to the bottom of the fill plug hole. Do not overfill.
7. Reinstall the fill plug. Torque to specification.
8. Check for leaks. Discard used fluid properly.



Drain Plug
(bottom view)

MAINTENANCE

Demand Drive Unit (Front Gearcase)

Always check and change the fluid at the intervals outlined in the Periodic Maintenance Chart beginning on page 69. Refer to the Gearcase Specifications Chart on page 84 for recommended lubricants, capacities and torque specifications.

Fluid Check

The fill plug is located on the bottom right side of the demand drive unit. Maintain the fluid level even with the bottom thread of the fill plug hole.

1. Position the vehicle on a level surface.
2. Remove the fill plug. Check the fluid level.
3. Add the recommended fluid to the bottom thread of the fill plug hole.
4. Reinstall the fill plug. Torque to specification.



Fill Plug

Demand Drive Unit (Front Gearcase) Fluid Change

The drain plug is located on the bottom of the gearcase.

1. Remove the fill plug.
2. Place a drain pan under the drain plug.
3. Remove the drain plug. Allow the fluid to drain completely.
4. Clean the drain plug. If the o-ring is damaged, install a new o-ring.
5. Reinstall the drain plug. Torque to specification.
6. Add the recommended fluid to the bottom thread of the fill plug hole.
7. Reinstall the fill plug. Torque to specification.
8. Check for leaks. Discard used fluid properly.

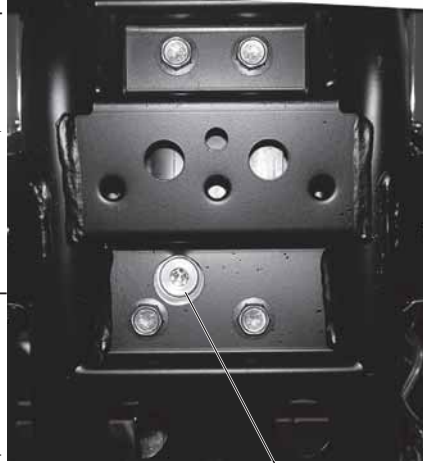

Drain Plug
(bottom view)

MAINTENANCE

Gearcases

Gearcase Specification Chart

Use of other fluids may result in improper operation of components. See page 124 for the part numbers of POLARIS products.

Gearcase	Lubricant	Capacity	Fill Plug Torque	Drain Plug Torque
Transmission (Main Gearcase)	Premium AGL Synthetic Gearcase Fluid	44 oz. (1300 ml)	10-14 ft. lbs. (14-19 Nm)	10-14 ft. lbs. (14-19 Nm)
Demand Drive Unit (Front Gearcase)	Demand Drive Plus Fluid	6.75 oz. (200 ml)	10-14 ft. lbs. (14-19 Nm)	10-14 ft. lbs. (14-19 Nm)

Spark Plugs

Spark Plug Gap/Torque

Electrode Gap	Spark Plug Torque
0.7-0.8 mm	10 ft. lbs. (13.5 Nm)

NOTICE: Using non-recommended spark plugs can result in serious engine damage. Always use POLARIS-recommended spark plugs. Refer to the specifications section beginning on page 120.

Spark plug condition is indicative of engine operation. The spark plug firing end condition should be read after the engine is warmed up and the vehicle is driven at higher speeds. Immediately check the spark plug for correct color. See page 85.

CAUTION! A hot exhaust system and engine can cause burns. Wear protective gloves when removing a spark plug for inspection.

Spark Plugs

Spark Plug Removal and Replacement

1. Remove the cargo box access panel.
2. Clean the area around the spark plugs before removing the plugs.
3. Remove the spark plug caps.
4. Using the spark plug wrench provided in the tool kit, remove the plugs by rotating them counter-clockwise.
5. Reverse the procedure for spark plug installation. Torque to specification. See page 84.

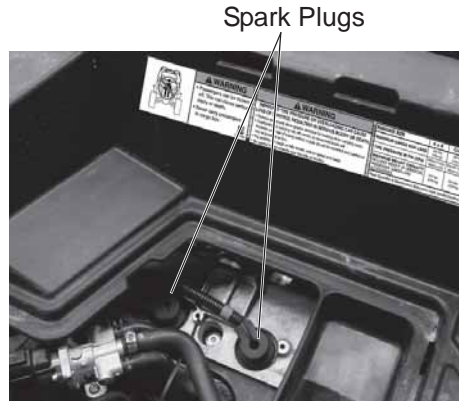

Spark Plug Condition

Normal Plug

The normal insulator tip is gray, tan or light brown. There will be few combustion deposits. The electrodes are not burned or eroded. This indicates the proper type and heat range for the engine and the service.

Tip: The tip should not be white. A white insulator tip indicates overheating, caused by use of an improper spark plug or incorrect throttle body adjustments.

Wet Fouled Plug

The wet fouled insulator tip is black. A damp oil film covers the firing end. There may be a carbon layer over the entire nose. Generally, the electrodes are not worn. Fouling may be caused by excessive oil or by frequent short trips, especially in cold weather.

MAINTENANCE

Fuses

If the engine stops or will not start, or if you experience other electrical failures, a fuse may need replacement. Locate and correct any short circuits that may have caused the blown fuse, then replace the fuse.

Main Fuse	Feature Supported
20A	Lights: Headlights, Taillights
10A	Drive: AWD
20A	Accessory: Winch Switch, 12V Power Receptacle
10A	Fuel Pump
20A	Electronic Engine Control, Starting
Power Fuse	Feature Supported
30A	Engine Control
30A	Lights, Drive, Accessories

The main fuse box is located under the dash, above the brake and throttle pedals. Spare fuses are provided in the fuse box.

The power fuse box is located under the driver's seat. Remove the engine access panel to access the fuse box.



Main
Fuse
Box

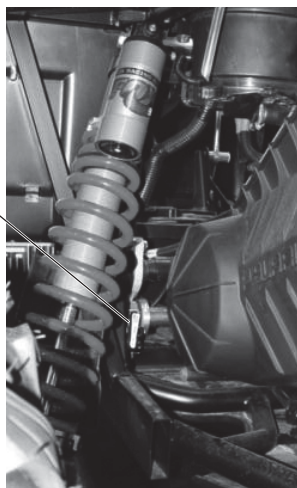

Power
Fuse
Box

Fuses

Main Fuse Box

1. Lift up on the two fuse box tabs.
2. Slide the fuse box slightly toward the right side of the vehicle to disengage it from the mount.
3. Remove the fuse box cover.
4. Remove the suspect fuse from the fuse panel. If the fuse is blown, install a new fuse with the same amperage rating.
5. Reinstall the fuse box cover. Reinstall the fuse box over the mount and slide it toward the left to engage the tabs. Be sure the fuse box is securely mounted.

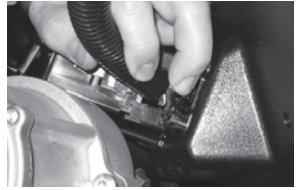

Step 1 - Lift tabs



Step 3 - Cover removed

MAINTENANCE

Cooling System

The engine coolant level is maintained by the recovery system. The recovery system components are the overflow bottle, radiator vent fitting, radiator pressure cap and connecting hose.

As coolant operating temperature increases, the expanding (heated) excess coolant is forced out of the radiator, past the pressure cap, and into the overflow bottle. As engine coolant temperature decreases, the contracting (cooled) coolant is drawn back up from the tank, past the pressure cap, and into the radiator.

Tip: Some coolant level drop on new vehicles is normal as the system is purging itself of trapped air. Observe coolant levels and maintain as recommended by adding coolant to the overflow bottle.

Adding or Changing Coolant

To ensure that the coolant maintains its ability to protect the engine, we recommend that the system be completely drained every two years and a fresh mixture of antifreeze and water added. See page 89 for changing procedure.

POLARIS recommends the use of POLARIS Premium 60/40 anti-freeze/coolant or a 50/50 mixture of high quality aluminum compatible anti-freeze/coolant and distilled water. POLARIS Premium 60/40 is already premixed and ready to use. Do not dilute with water. See page 124 for the part numbers of POLARIS products.

Tip: Always follow the manufacturer's mixing recommendations for the freeze protection required in your area.

Any time the cooling system has been drained for maintenance or repair, replace the coolant.

Radiator and Cooling Fan

Always check and clean the screen and radiator fins at the intervals outlined in the Periodic Maintenance Chart beginning on page 69. Do not obstruct or deflect air flow through the radiator by installing unauthorized accessories in front of the radiator or behind the cooling fan. Interference with the radiator air flow can lead to overheating and consequent engine damage.

NOTICE: Washing the vehicle with a high-pressure hose could damage the radiator fins and impair the radiator's effectiveness. Using a high-pressure system is not recommended.

Cooling System

Radiator Coolant Level/Changing Coolant

This procedure is required only if the cooling system has been drained for maintenance and/or repair. If the overflow bottle has run dry, the level in the radiator should also be inspected.

CAUTION! Escaping steam can cause burns. Never remove the pressure cap while the engine is warm or hot. Always allow the engine to cool before removing the pressure cap.

1. Remove the hood. See page 34.
2. Slowly remove the radiator pressure cap.
3. View the coolant level through the opening.
4. Use a funnel and slowly add coolant as needed.
5. Before reinstalling the pressure cap, bleed the system of trapped air. Remove the engine access panel behind the seats and use a flat-blade screwdriver to turn the bleed screw slightly, allowing the air to escape. Slowly add additional coolant to the radiator until air no longer escapes and only coolant flows from the bleed hole, then tighten the bleed screw.
6. Reinstall the pressure cap.

Tip: Use of a non-standard pressure cap will not allow the recovery system to function properly. See your dealer for the correct replacement part.

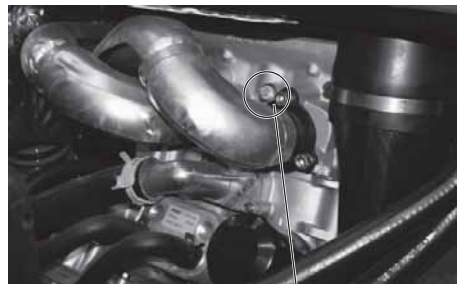

Bleed Screw

MAINTENANCE

Cooling System

Overflow Bottle Coolant Level

Always check and change the coolant at the intervals outlined in the Periodic Maintenance Chart beginning on page 69. Maintain the coolant level between the minimum and maximum marks on the bottle (when the fluid is cool). If the overflow bottle has run dry, the level in the radiator should also be inspected.

1. Position the vehicle on a level surface.
2. Remove the hood. See page 34.
3. View the coolant level in the overflow bottle.
4. Remove the cap and use a funnel to add coolant as needed to maintain the level between the two marks.
5. Reinstall the cap.

Tip: If coolant must be added often, or if the overflow bottle runs completely dry, there may be a leak in the system. Have the cooling system inspected by your POLARIS dealer.



MAINTENANCE

POLARIS Variable Transmission (PVT) System

WARNING

Failure to comply with the instructions in this warning can result in severe injury or death.

Do not modify any component of the PVT system. Doing so may reduce its strength so that a failure may occur at a high speed. The PVT system has been precision balanced. Any modification will cause the system to be out of balance, creating vibration and additional loads on components.

The PVT system rotates at high speeds, creating large amounts of force on clutch components. Extensive engineering and testing has been conducted to ensure the safety of this product. However, as the owner, you have the following responsibilities to make sure this system remains safe:

- Always follow all recommended maintenance procedures. Always look for and remove debris inside and around the clutch and vent system when replacing the belt.
- See your dealer as recommended in the owner's manual and on safety labels.
- This PVT system is intended for use on POLARIS products only. Do not install it in any other product.
- Always make sure the PVT housing is securely in place during operation.

MAINTENANCE

POLARIS Variable Transmission (PVT) System Belt Replacement/Debris Removal

If a belt fails, always clean any debris from the duct and from the clutch and engine compartments when replacing the belt.

WARNING! Failure to remove ALL debris when replacing the belt could result in vehicle damage and severe injury or death.

1. Remove the engine access cover and thoroughly clean all debris from the aluminum debris basket and from the engine compartment.
2. Remove the clutch cover screws and open the clutch cover. (It does not have to be removed from the vehicle.) Remove all debris wrapped in and around the PVT system.

Tip: Use the shock/clutch tool from the tool kit to slightly open the sheaves to aid in debris removal and belt installation.

(Continued on next page)



Debris Basket



Remove ALL Debris



Insert hooked end of tool.



Apply force to opposite end of tool to spread sheaves.

MAINTENANCE

POLARIS Variable Transmission (PVT) System Belt Replacement/Debris Removal

3. Remove all debris from the entire clutch air duct passage.
4. Check for signs of damage to seals on the transmission and engine. See your dealer promptly for service if any seals appear to be damaged.

Tip: Belt slip is responsible for creating excessive heat that destroys belts, wears clutch components and causes outer clutch covers to fail. Switch to low range while operating at slower speeds to extend the life of the PVT components (belt, cover, etc.).



Clutch Air Duct

PVT Drying

There may be some instances when water is accidentally ingested into the PVT system. Use the following instructions to dry it out before operating.

1. Remove the clutch cover drain plug.
2. Allow the water to drain. Reinstall the drain plug.
3. Place the transmission in PARK. Apply the brakes.
4. Start the engine.
5. Apply varying throttle for 10-15 seconds to expel the moisture and air-dry the belt and clutches. Do not hold the throttle wide open for more than 10 seconds.
6. Allow the engine RPM to settle to idle speed. Apply the brakes. Shift the transmission to the lowest available range.
7. Test for belt slippage. If the belt slips, repeat the process.
8. Take the vehicle to your dealer for service as soon as possible.

MAINTENANCE

Filter Systems

Fuel Tank Vent Filter

If the engine sputters, the inline fuel tank vent filter may be clogged. Do not attempt to clean the filter. Replace the filter with a new filter.

1. Remove the seats and remove the engine access panel.

Tip: Note the direction of the arrow on the filter before removing it.

2. Remove the filter and install the new filter. Make sure the direction of the arrow is the same as noted before filter removal.

3. Reinstall the access panel and seats.

Fuel Tank Vent Filter



Intake Pre-Filters

The engine intake pre-filter is located on the left side of the cargo box. The PVT intake pre-filter is located on the right side of the cargo box.

Inspect the pre-filters before each use of the vehicle.

Remove the pre-filters and use compressed air to clean them frequently to ensure adequate air flow.

PVT Intake Pre-Filter



Filter Systems

Air Filter

Always change the air filter at the intervals outlined in the Periodic Maintenance Chart beginning on page 69.

1. Remove the cargo box access panel.
2. Loosen the air box cover wing nuts and rotate the bolts away from the cover.
3. Release the cover latches.
4. Pull the cover rearward far enough to remove the air filter.
5. Inspect the air box for oil or water deposits. Wipe away any deposits with a clean cloth.
6. Install a new filter if needed. Do not attempt to clean the air filter.
7. Close the air box cover and tighten the wing nuts and bolts securely.

Wing Nuts/Bolts

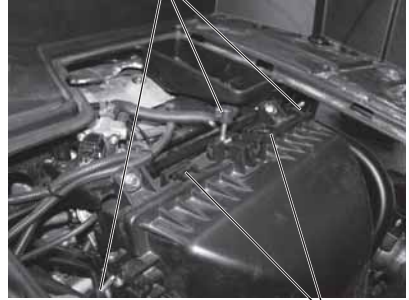

Cover Latches



Air Filter

MAINTENANCE

Spark Arrester

WARNING

Failure to heed the following warnings while servicing the spark arrester could result in serious injury or death.

Do not perform clean-out immediately after the engine has been run, as the exhaust system becomes very hot. Serious burns could result from contact with the exhaust components. Allow components to cool sufficiently before proceeding.

Wear eye protection and gloves.

Never run the engine in an enclosed area. Exhaust contains poisonous carbon monoxide gas that can cause loss of consciousness or death in a very short time.

Spark Arrester

Periodically clean the spark arrester to remove accumulated carbon.

1. Remove the arrester retaining bolt and nut.
2. Remove the arrester from the end of the muffler.
3. Use a non-synthetic brush to clean the arrester screen. A synthetic brush may melt if components are warm. If necessary, blow debris from the screen with compressed air.
4. Inspect the screen for wear and damage. Replace a worn or damaged screen.
5. Reinstall the arrester. Torque bolt to 9-11 ft. lbs. (12-15 Nm).

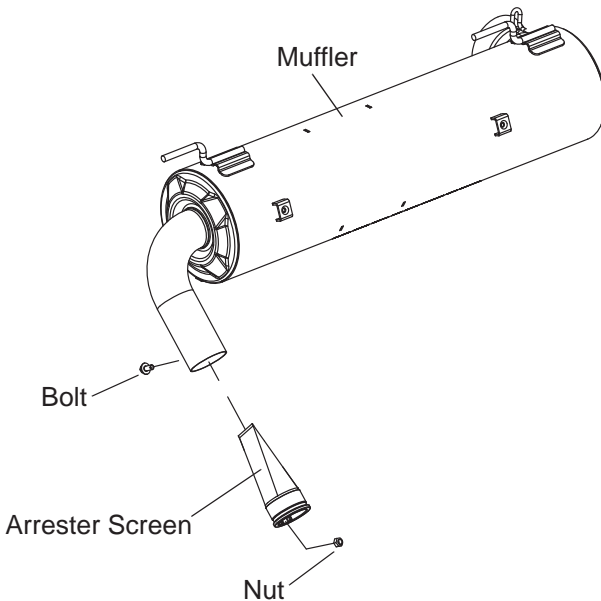

MAINTENANCE

Throttle System

⚠ WARNING

Failure to check or maintain proper operation of the throttle system can result in an accident and lead to serious injury or death if the throttle pedal sticks during operation.

Never start or operate this vehicle if it has a sticking or improperly operating throttle pedal.

Immediately contact your dealer for service if throttle problems arise.

Always check the pedal for free movement and return before starting the engine and occasionally during operation.

Throttle Freeplay

If the throttle pedal has excessive play due to cable stretch or misadjustment, it will cause a delay in throttle response, especially at low engine speed. The throttle may also not open fully.

If the throttle pedal has no freeplay, the throttle may be hard to control, and the idle speed may be erratic. If engine idle speed is not satisfactory, please see your POLARIS dealer for adjustment.

Throttle Body/Idle RPM

Idle RPM is preset by the manufacturer. If the engine idle speed is not satisfactory, please see your POLARIS dealer for adjustment.



Throttle Pedal

Brakes

The front and rear brakes are hydraulic disc type brakes activated by the brake pedal. See page 39.

Always check brake pedal travel and the brake fluid reservoir level before each use of the vehicle. When applied, the brake pedal should feel firm. Any sponginess would indicate a possible fluid leak or low brake fluid level, which must be corrected before riding. See page 100 for brake fluid information.

If you discover any irregularities in brake system operation, including excessive pedal travel, contact your dealer for proper diagnosis and repairs.

WARNING! Operating the vehicle with a spongy brake pedal can result in loss of braking, which could cause an accident resulting in severe injury or death. Never operate the vehicle with a spongy-feeling brake pedal.

Brake Inspection

1. Check the brake system for fluid leaks.
2. Check the brake pedal for excessive travel or a spongy feel.
3. Check the friction pads for wear, damage and looseness.
4. Inspect the brake pad wear surface for excessive wear.
5. Change pads when worn to 3/64" (1 mm).

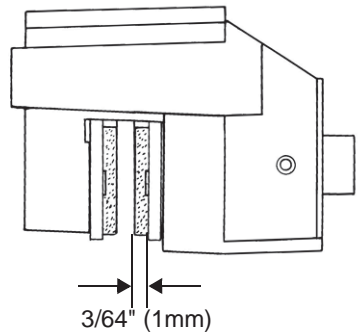

MAINTENANCE

Brakes

Brake Fluid

Inspect the level of the brake fluid before each operation. If the fluid level is low add DOT 4 brake fluid only. See page 124 for the part numbers of POLARIS products.

WARNING! After opening a bottle of brake fluid, always discard any unused portion. Never store or use a partial bottle. Brake fluid is hygroscopic, meaning it rapidly absorbs moisture from the air. The moisture causes the boiling temperature of the brake fluid to drop, which can lead to early brake fade and the possibility of accident or severe injury.

Change the brake fluid every two years and any time the fluid becomes contaminated, the fluid level is below the minimum, or if the type and brand of the fluid in the reservoir are unknown. Access the brake fluid reservoir through the left front wheel well.

1. Position the vehicle on a level surface.
2. Place the transmission in PARK.
3. View the brake fluid level in the reservoir. The level should be between the maximum and minimum level lines.
4. If the fluid level is lower than the lower level line, add brake fluid to the upper line.
5. Apply the brake forcefully for a few seconds and check for fluid leakage around the fittings.

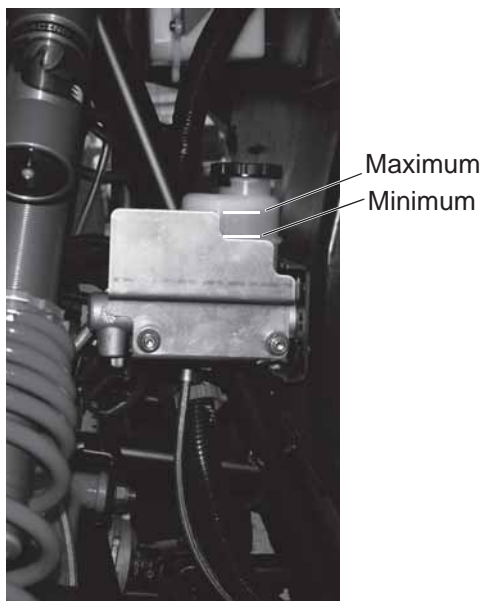

Suspension Settings

Front/Rear Spring Preload

The factory setting is appropriate for nearly all riding conditions. If desired, the suspension may be adjusted to maintain vehicle clearance height when carrying loads.



Fox Shock Preload Measurement

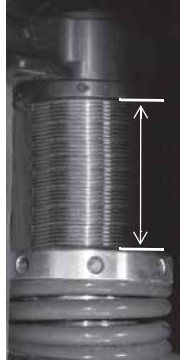

Walker Evans Front Shock Preload Measurement



Walker Evans Rear Shock Preload Measurement

Factory Preload Settings	
RZR XP Premium Front	7.625" (193.7 mm)
RZR XP Premium Rear	3.625" (92.1 mm)
RZR XP 4 Front	6.560" (166.6 mm)
RZR XP 4 Rear	0.940" (23.9 mm)

MAINTENANCE

Suspension Settings

Front/Rear Spring Preload

Fox Shock Preload Adjustment

Follow these guidelines if you make adjustments to this suspension.

- Always return the suspension to the factory setting after the load is removed from the vehicle. The increased suspension height will negatively impact vehicle stability when operating without a load.
 - Always apply the same adjustment setting to *all four wheels*.
 - Do not increase the spring preload by more than one inch (25.4 mm) over the factory setting.
1. Use the shock/clutch tool from the tool kit to aid in making suspension adjustments.
 2. Elevate the vehicle to allow the suspension to fully extend.
 3. Loosen the jam nut and back it away from the adjusting ring.
 4. Turn the adjusting ring to the left (1) to increase preload for a stiffer ride. Turn the adjusting ring to the right (2) to decrease preload for a softer ride.

WARNING! Uneven adjustment may cause poor handling of the vehicle, which could result in an accident. Always adjust both the left and right spring preloads equally or have your POLARIS dealer perform the adjustments.

5. Tighten the jam nut firmly against the adjuster ring.

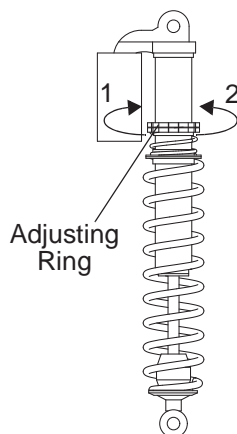

Suspension Settings

Front/Rear Spring Preload

Walker Evans Shock Preload Adjustment

Follow these guidelines if you make adjustments to this suspension.

- Always return the suspension to the factory setting after the load is removed from the vehicle. The increased suspension height will negatively impact vehicle stability when operating without a load.
 - Always apply the same adjustment setting to *all four wheels*.
 - Do not increase the spring preload by more than one inch (25.4 mm) over the factory setting.
1. Use the shock/clutch tool from the tool kit to aid in making suspension adjustments.
 2. Elevate the vehicle to allow the suspension to fully extend.
 3. Turn the adjusting ring to the left (1) to increase preload for a stiffer ride. Turn the adjusting ring to the right (2) to decrease preload for a softer ride.

WARNING! Uneven adjustment may cause poor handling of the vehicle, which could result in an accident. Always adjust both the left and right spring preloads equally or have your POLARIS dealer perform the adjustments.

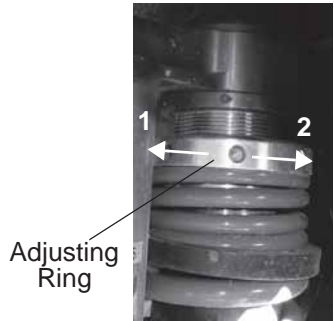

MAINTENANCE

Suspension Settings

Front/Rear Shock Compression

The compression damping clicker knob is located on top of the shock reservoir. When the knob is turned clockwise until it stops, the damping is in the fully closed position.

1. Turn the clicker clockwise to increase compression damping.
2. Turn the clicker counter-clockwise to decrease compression damping.

FOX Shocks	
Setting	Compression Damping
Softest	20 clicks from closed
Factory	10 clicks from closed
Firmer	2 clicks from closed
Walker Evans Shocks	
Setting	Compression Damping
Softest	16 clicks from closed
Factory	7 clicks from closed
Firmer	1 click from closed

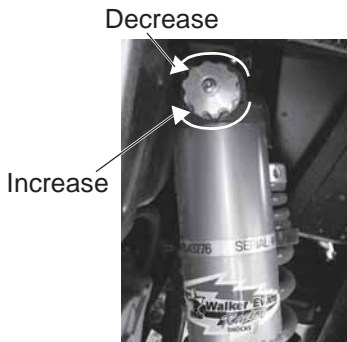
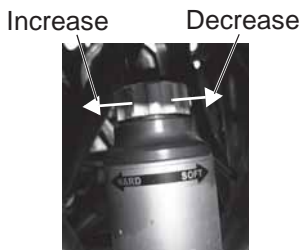

Tires

⚠ WARNING

Operating your vehicle with worn tires will increase the possibility of skidding, loss of control and an accident, which could result in serious injury or death. Always replace tires when the tread depth measures 1/8" (3 mm) or less.

Improper tire inflation or the use of non-standard size or type of tires may adversely affect vehicle handling, which could result in vehicle damage or personal injury. Always maintain proper tire pressure. When replacing tires, always use original equipment size and type.

Tire Tread Depth

Always replace tires when tread depth is worn to 1/8" (3 mm) or less.

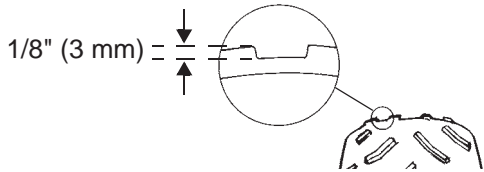

Axle and Wheel Nut Torque Specifications

Inspect the following items occasionally for tightness, and if they've been loosened for maintenance service. *Do not lubricate the stud or the lug nut.*

Lug Nut (Aluminum Wheels)		Front and Rear	30 ft. lbs. (41 Nm) PLUS 1/4 TURN
Hub Retaining Nut		Front and Rear	80 ft. lbs. (108 Nm)

MAINTENANCE

Tires

Wheel Removal

1. Position the vehicle on a level surface.
2. Place the transmission in PARK. Stop the engine.
3. Loosen the wheel nuts slightly.
4. Elevate the side of the vehicle by placing a suitable stand under the frame.
5. Remove the wheel nuts and washers. Remove the wheel.

Wheel Installation

1. Place the transmission in PARK.
2. Place the wheel in the correct position on the wheel hub. Be sure the valve stem is toward the outside and rotation arrows on the tire point toward forward rotation.

WARNING! Improperly installed wheels can adversely affect tire wear and vehicle handling, which can result in serious injury or death. Always ensure that all nuts are torqued to specification. Do not service axle nuts that have a cotter pin installed. See your POLARIS dealer.

3. Attach the wheel nuts and washers and finger tighten.
4. Carefully lower the vehicle to the ground.
5. Torque the wheel nuts to specification. See page 105.

**Right Rear Wheel
(type varies by model)**



Forward
Rotation

Valve Stem

Lights

Headlight and taillight lenses become dirty during normal operation. Clean all lights frequently to ensure a clear field of vision as well as visibility to other vehicles.

Tip: If an LED headlamp has moisture or fogging inside, disconnect the wiring harness from the headlamp(s) for a few days to allow the moisture to clear out.

Brake Lights

When the brake pedal is depressed, the brake light comes on. Check the brake light before each ride.

1. Turn the ignition switch to the ON position.
2. Apply the brakes. The brake light should come on after about 10 mm (0.4 in.) of pedal travel. If the light doesn't come on, check the bulb.

Headlight Replacement

If a headlight becomes damaged or inoperable, the entire headlight assembly must be replaced.



Headlight Rear View

MAINTENANCE

Lights

Headlight Beam Adjustment

The headlight beam can be adjusted slightly upward or downward and to the left or right.

1. Position the vehicle on a level surface. The headlight should be approximately 25 ft. (7.6 m) from a wall.

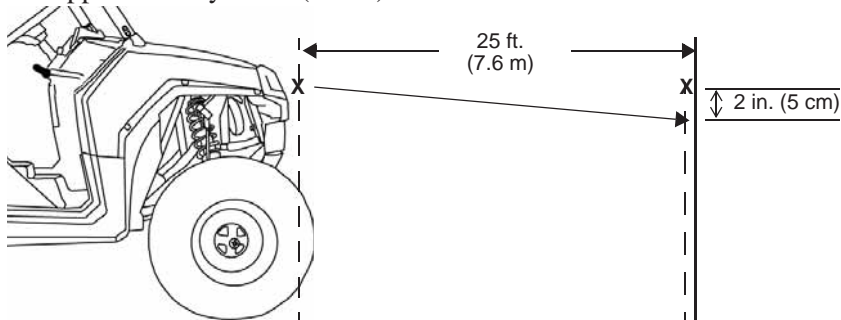

2. Place the transmission in PARK.
3. Measure the distance from the floor to the center of the headlight and make a mark on the wall at the same height.
4. Apply the brakes. Start the engine. Turn the headlights to high beam.
5. Include the weight of a rider on the seat while performing this step. Observe the headlight aim. As a starting point, the most intense part of the headlight beam should be 2 inches (5 cm) below the mark on the wall. Adjust to operator preference.
6. Tighten or loosen the three (3) headlight screws to adjust the beam upward or downward or to the left or right.



Adjustment
Screws

Vehicle Immersion

NOTICE: If your vehicle becomes immersed, major engine damage can result if the machine is not thoroughly inspected. Take the vehicle to your dealer before starting the engine.

If it's impossible to take your vehicle to a dealer before starting it, follow the steps outlined below.

1. Move the vehicle to dry land.
2. Check the air box. If water is present, dry the air box and replace the filter with a new filter.
3. Dry the spark plug wells with a clean cloth, then remove the spark plugs.
4. Turn the engine over several times.
5. Dry the spark plugs and reinstall them, or install new plugs.
6. Attempt to start the engine. If necessary, repeat the drying procedure.
7. Take the vehicle to your dealer for service as soon as possible, whether you succeed in starting it or not.
8. If water has been ingested into the PVT follow the procedure on page 93 for drying.

MAINTENANCE

Steering Wheel Inspection

Check the steering wheel for specified freeplay and smooth operation at the intervals outlined in the Periodic Maintenance Chart beginning on page 69.

1. Position the vehicle on level ground.
2. Lightly turn the steering wheel left and right.
3. There should be 0.8-1.0" (20-25 mm) of freeplay.
4. If there is excessive freeplay or strange noises, or if the steering feels rough or "catchy," have the steering system inspected by an authorized POLARIS dealer.

Battery

WARNING

Improperly connecting or disconnecting battery cables can result in an explosion and cause serious injury or death. When removing the battery, always disconnect the negative (black) cable first. When reinstalling the battery, always connect the negative (black) cable last.

Your vehicle has a sealed battery, which requires little maintenance. Always keep battery terminals and connections free of corrosion. If cleaning is necessary, remove the corrosion with a stiff wire brush. Wash with a solution of one tablespoon baking soda and one cup water. Rinse well with tap water and dry off with clean shop towels. Coat the terminals with dielectric grease or petroleum jelly.

Battery Removal

1. Remove the driver's seat. See page 32.
2. Disconnect the black (negative) battery cable first.
3. Disconnect the red (positive) battery cable last.
4. Remove the battery hold-down strap.
5. Lift the battery out of the vehicle.

MAINTENANCE

Battery

Battery Installation

Using a new battery that has not been fully charged can damage the battery and result in a shorter life. It can also hinder vehicle performance. Follow the battery charging instructions on page 113 before installing the battery.

1. Ensure that the battery is fully charged.
2. Place the battery in the battery holder.
3. Coat the terminals with dielectric grease or petroleum jelly.
4. Secure the battery hold-down strap.
5. Connect and tighten the red (positive) cable first.
6. Connect and tighten the black (negative) cable last.
7. Verify that cables are properly routed.
8. Reinstall the driver's seat.

Battery Storage

Whenever the vehicle is not used for a period of three months or more, recharge the battery about once a month to make up for normal self-discharge (see page 113), or use a POLARIS Battery Tender, which can be left connected during the storage period. Battery Tender will automatically charge the battery if voltage drops below a pre-determined point. See page 124 for the part numbers of POLARIS products.

During the storage period, park the vehicle out of the sun in a cool, dry place or remove the battery and store it in a cool, dry place.

Battery

Battery Charging

The following battery charging instructions apply only to the installation of a sealed battery. Read all instructions before proceeding with the installation of this battery.

The sealed battery is already filled with electrolyte and has been sealed and *fully charged* at the factory. *Never* pry the sealing strip off or add any other fluid to this battery.

A sealed battery must always be maintained with a full charge. Since the battery is sealed and the sealing strip cannot be removed, you must use a voltmeter or multimeter to measure DC voltage.

WARNING! An overheated battery may explode, causing severe injury or death. Always watch charging times carefully. Stop charging if the battery becomes very warm to the touch. Allow it to cool before resuming charging.

For a refresh charge, follow all instructions carefully.

1. The battery should be disconnected from a load or charger for at least two hours before checking voltage. Check the battery voltage with a voltmeter or multimeter. A fully charged battery will register 12.8 V or higher.
2. If the voltage is less than 12.8 volts, recharge the battery at 1.2 amps or less until battery voltage is 12.8 or greater.
3. When using an automatic charger, refer to the charger manufacturer's instructions for recharging. When using a constant current charger, use the guidelines on the next page for recharging.

MAINTENANCE

Battery

Battery Charging

Always verify battery condition before and 1-2 hours after the end of charging.

State of Charge	Voltage	Action	Charge Time (Using constant current charger @ standard amps specified on top of battery)
100%	12.8-13.0 volts	None, check at 3 mos. from date of manufacture	None required
75%-100%	12.5-12.8 volts	May need slight charge, if no charge given, check in 3 months	3-6 hours
50%-75%	12.0-12.5 volts	Needs charge	5-11 hours
25%-50%	11.5-12.0 volts	Needs charge	At least 13 hours, verify state of charge
0%-25%	11.5 volts or less	Needs charge with desulfating charger	At least 20 hours

Cleaning and Storage

Washing the Vehicle

Keeping your POLARIS vehicle clean will not only improve its appearance but it can also extend the life of various components.

NOTICE: Water in the PVT system could cause the drive belt to become wet and slip in the clutches. Always avoid spraying water directly toward any intake pre-filters.

High water pressure may damage components. POLARIS recommends washing the vehicle by hand or with a garden hose, using mild soap.

Certain products, including insect repellents and chemicals, will damage plastic surfaces. Do not allow these types of products to contact the vehicle.

PVT Intake Pre-Filter



The best and safest way to clean your POLARIS vehicle is with a garden hose and a pail of mild soap and water.

1. Use a professional-type washing cloth, cleaning the upper body first and the lower parts last.
2. Rinse with clean water frequently.
3. Dry surfaces with a chamois to prevent water spots.

Washing Tips

- Avoid the use of harsh cleaners, which can scratch the finish.
- Do not use a power washer to clean the vehicle.
- Do not use medium to heavy duty compounds on the finish.
- Always use clean cloths and pads for cleaning and polishing. Old or reused cloths and pads may contain dirt particles that will scratch the finish.

MAINTENANCE

Cleaning and Storage

Washing the Vehicle

If a high pressure water system is used for cleaning (not recommended), exercise extreme caution. The water may damage components and could remove paint and labels. Avoid directing the water stream at the following items:

- Wheel bearings
- Radiator
- Transmission seals
- Brakes
- Cab and body panels
- Labels and decals
- Electrical components and wiring
- Air intake components

If warning and safety labels are damaged, contact your POLARIS dealer for free replacement.

Grease all zerk fittings immediately after washing. Allow the engine to run for a while to evaporate any water that may have entered the engine or exhaust system.

Polishing the Vehicle

POLARIS recommends the use of common household aerosol furniture polish for polishing the finish on your POLARIS vehicle. Follow the instructions on the container.

Polishing Tips

- Avoid the use of automotive products, some of which can scratch the finish of your vehicle.
- Always use clean cloths and pads for cleaning and polishing. Old or reused cloths and pads may contain dirt particles that will scratch the finish.

Cleaning and Storage

Storage Tips

NOTICE: Starting the engine during the storage period will disturb the protective film created by fogging and damage could occur. Never start the engine during the storage period.

Clean the Exterior

Make any necessary repairs and clean the vehicle as recommended. See page 115.

Stabilize the Fuel

1. Fill the fuel tank.
2. Add POLARIS Carbon Clean Fuel Treatment or POLARIS Fuel Stabilizer. Follow the instructions on the container for the recommended amount. Carbon Clean removes water from fuel systems, stabilizes fuel and removes carbon deposits from pistons, rings, valves and exhaust systems.
3. Allow the engine to run for 15-20 minutes to allow the stabilizer to disperse through the entire fuel delivery system.

Oil and Filter

Change the oil and filter. See page 78.

Air Filter / Air Box

Replace the air filter. See page 95. Clean the air box. Drain the sediment tube.

Fluid Levels

Inspect the fluid levels. Add or change fluids as recommended in the Periodic Maintenance Chart beginning on page 69.

- Demand drive fluid (front gearcase)
- Rear gearcase fluid (if equipped)
- Transmission fluid
- Brake fluid (change every two years and any time the fluid looks dark or contaminated)
- Coolant (test strength/fill)

MAINTENANCE

Cleaning and Storage

Storage Tips

Inspect and Lubricate

Inspect all cables and lubricate all areas of the vehicle as recommended in the Periodic Maintenance Chart beginning on page 69.

Fog the Engine

1. Treat the fuel system with POLARIS Carbon Clean. Follow the instructions on the container. Start the engine. Allow it to idle for several minutes so the Carbon Clean reaches the injectors. Stop the engine.
2. Remove the spark plugs and add 2-3 tablespoons of engine oil. To access the plug holes, use a section of clear 1/4" hose and a small plastic squeeze bottle filled with the pre-measured amount of oil. *Do this carefully! If you miss the plug holes, oil will drain from the spark plug cavities into the hole at the front of the cylinder head, and appear to be an oil leak.*
3. Reinstall the spark plugs. Torque to specification. See page 85.
4. Apply dielectric grease to the inside of each spark plug cap. *Do not reinstall the caps onto the plugs at this step.*
5. Turn the engine over several times. Oil will be forced in and around the piston rings and ring lands, coating the cylinder with a protective film of fresh oil.
6. If POLARIS fuel system additive is not used, fuel tank, fuel lines, and injectors should be completely drained of gasoline.
7. Reinstall the spark plug caps to the spark plugs.

Battery Maintenance

See pages 112-114 for storage and charging procedures.

Storage Area/Covers

Be sure the storage area is well ventilated. Cover the vehicle with a genuine POLARIS cover. Do not use plastic or coated materials. They do not allow enough ventilation to prevent condensation, and may promote corrosion and oxidation.

Cleaning and Storage

Removal from Storage

1. Charge the battery if necessary.
2. Make sure the spark plug is tight.
3. Fill the fuel tank with fuel.
4. Check all the points listed in the Daily Pre-Ride Inspection section on page 52. Tightness of the bolts, nuts and other fasteners should be checked by an authorized POLARIS dealer.
5. Lubricate at the intervals outlined in the Periodic Maintenance Chart beginning on page 69.

WARNING! Engine exhaust contains poisonous carbon monoxide and can cause loss of consciousness or death. Never run an engine in an enclosed area.

Transporting the Vehicle

Follow these procedures when transporting the vehicle.

1. Place the transmission in PARK. Stop the engine.
2. Remove the key to prevent loss during transporting.
3. Secure the fuel cap and seats.
4. Always tie the frame of the POLARIS vehicle to the transporting unit securely with suitable straps or rope. Do not attach tie straps to the front control arm bolt pockets.

Front Tie-Down Points
(one on each side)

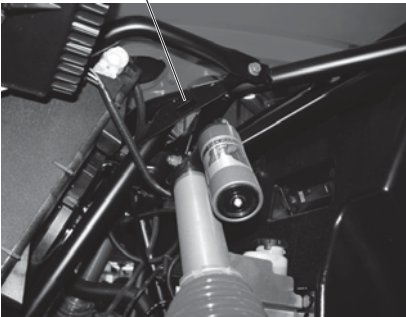

Rear Tie-Down Points

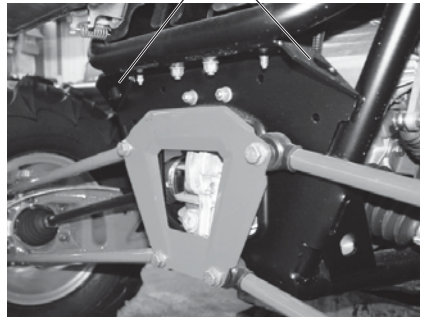

SPECIFICATIONS

RANGER RZR XP 900

Gross Vehicle Weight	1930 lbs. (875 kg)
Dry Weight	1190 lbs. (540 kg)
Rear Cargo Box Capacity	300 lbs. (136 kg)
Maximum Weight Capacity (Payload)	740 lbs. (336.4 kg) (including riders, cargo and accessories)
Fuel Capacity	7.75 gal. (29 l)
Engine Oil Capacity	3.5 qts. (3.3 l)
Coolant Capacity	4.9 qts. (4.6 l)
Demand Drive Fluid Capacity	6.75 oz. (200 ml)
Transmission Oil Capacity	44 oz. (1300 ml)
Overall Length/Width/Height	108.4/64/73 in. (275/162.5/185.4 cm)
Wheelbase	81.4 in. (206.8 cm)
Ground Clearance	13 in. (33 cm)
Engine	4-Stroke DOHC Twin Cylinder
Displacement	875 cc
Bore x Stroke	93mm x 64.4mm
Alternator Output	720 W @ 3000 RPM
Compression Ratio	10.5:1
Starting System	Electric
Fuel System	Electronic fuel injection
Ignition System	ECU
Spark Plug / Gap	RG4YCX / 0.7-0.8 mm
Front Suspension	Independent double a-arm with 13.5 in. (34.3 cm) travel
Rear Suspension	Independent trailing arms with 14 in. (35.5 cm) travel

SPECIFICATIONS

RANGER RZR XP 900

Lubrication System	Dry Sump
Driving System Type	Automatic POLARIS Variable Transmission
Shift Type	Dual Range P/R/N/L/H
Gear Reduction - Low	6.45:1
Gear Reduction - Reverse	5.776:1
Gear Reduction - High	3.037:1
Drive Ratio - Front	3.82:1
Drive Ratio - Final	3.53:1
Tire Size - Front	27x9-12
Tire Size - Rear	27x11-12
Tire Pressure - Front	12 psi (82.7 KPa)
Tire Pressure - Rear	14 psi (96.5 KPa)
Brakes, Front/Rear	Foot Activated, 4-wheel hydraulic disc
Headlights	2 dual beam, 6-LED cluster, 40w High / 27w Low
Taillights	2 single beam, 5w
Brake Lights	2 single beam, 5w
Instrument Cluster	LCD
Auxiliary DC Outlet	12V

Clutching

Please see your POLARIS dealer for clutching specifications.

SPECIFICATIONS

RANGER RZR XP 4 900	
Gross Vehicle Weight	2375 lbs. (1077 kg)
Dry Weight	1390 lbs. (630.5 kg)
Rear Cargo Box Capacity	300 lbs. (136 kg)
Maximum Weight Capacity (Payload)	900 lbs. (408 kg) (including riders, cargo and accessories)
Fuel Capacity	7.75 gal. (29 l)
Engine Oil Capacity	3.5 qts. (3.3 l)
Coolant Capacity	9.7 qts. (9.2 l)
Demand Drive Fluid Capacity	6.75 oz. (200 ml)
Transmission Oil Capacity	44 oz. (1300 ml)
Overall Length/Width/Height	134.4/64/77 in. (341.4/162.5/195.6 cm)
Wheelbase	107.4 in. (272.8 cm)
Ground Clearance	12.5 in. (31.7 cm)
Engine	4-Stroke DOHC Twin Cylinder
Displacement	875 cc
Bore x Stroke	93mm x 64.4mm
Alternator Output	720 W @ 3000 RPM
Compression Ratio	10.5:1
Starting System	Electric
Fuel System	Electronic fuel injection
Ignition System	ECU
Spark Plug / Gap	RG4YCX / 0.7-0.8 mm
Front Suspension	Independent double a-arm with 13.5 in. (34.3 cm) travel
Rear Suspension	Independent trailing arms with 14 in. (35.5 cm) travel

SPECIFICATIONS

RANGER RZR XP 4 900

Lubrication System	Dry Sump
Driving System Type	Automatic POLARIS Variable Transmission
Shift Type	Dual Range P/R/N/L/H
Gear Reduction - Low	6.45:1
Gear Reduction - Reverse	5.776:1
Gear Reduction - High	3.037:1
Drive Ratio - Front	3.82:1
Drive Ratio - Final	3.53:1
Tire Size - Front	27x9-12
Tire Size - Rear	27x11-12
Tire Pressure - Front	14 psi (96.5 KPa)
Tire Pressure - Rear	16 psi (110.3 KPa)
Brakes, Front/Rear	Foot Activated, 4-wheel hydraulic disc
Headlights	2 dual beam, 6-LED cluster, 40w High / 27w Low
Taillights	2 single beam, 5w
Brake Lights	2 single beam, 5w
Instrument Cluster	LCD
Auxiliary DC Outlet	12V

Clutching

Please see your POLARIS dealer for clutching specifications.

POLARIS PRODUCTS

Part Number	Description
Engine Lubricant	
2870791	Fogging Oil (12 oz./355 ml Aerosol)
2876244	PS-4 PLUS Synthetic Engine Oil (qt./.95 l)
2876245	PS-4 PLUS Synthetic Engine Oil (gal./3.8 l)
Gearcase / Transmission Lubricants	
2878068	AGL PLUS Transmission Fluid (qt./.95 l)
2878069	AGL PLUS Transmission Fluid (gal./3.8 l)
2871653	Premium ATV Angle Drive Fluid (8 oz./237 ml)
2872276	Premium ATV Angle Drive Fluid (2.5 gal./9.5 l)
2870465	Pump for Gallon (3.8 l) Jug
2877922	Demand Drive Plus Fluid (qt./.95 l)
2877923	Demand Drive Plus Fluid (gal./3.8 l)
Coolant	
2871323	60/40 Coolant (gal./3.8 l)
2871534	60/40 Coolant (qt./.95 l)
Grease / Specialized Lubricants	
2871312	Grease Gun Kit, Premium All Season
2871322	Premium All Season Grease (3 oz./89 ml cartridge)
2871423	Premium All Season Grease (14 oz./414 ml cartridge)
2871460	Starter Drive Grease
2871515	Premium U-Joint Lube (3 oz./89 ml cartridge)
2871551	Premium U-Joint Lube (14 oz./414 ml cartridge)
2871329	Dielectric Grease (Nyogel™)
Additives / Miscellaneous	
2871326	Carbon Clean Plus
2870652	Fuel Stabilizer
2872189	DOT 4 Brake Fluid
2871956	Loctite™ 565 Thread Sealant
2859044	POLARIS Battery Tender™ Charger

TROUBLESHOOTING

Drive Belt Wear/Burn

Possible Cause	Solution
Driving onto a pickup or tall trailer in high range	Use low range during loading.
Starting out going up a steep incline	Use low range. See warnings on page 60.
Driving at low RPM or ground speed (3-7 MPH/ 5-11 km/h)	Drive at a higher speed or use low range more frequently. See page 38.
Insufficient warm-up at low ambient temperatures	Warm the engine at least 5 minutes. With the transmission in neutral, advance the throttle to about 1/8 throttle in short bursts, 5 to 7 times. The belt will become more flexible and prevent belt burning.
Slow/easy clutch engagement	Use the throttle quickly and effectively.
Hauling heavy cargo/ pushing at low RPM/low ground speed	Use low range only.
Utility use/plowing	Use low range only.
Stuck in mud or snow	Shift the transmission to low range and carefully use fast, aggressive throttle application to engage clutch. WARNING! Excessive throttle may cause loss of control and vehicle overturn.
Climbing over large objects from a stopped position	Shift the transmission to low range and carefully use fast, brief, aggressive throttle application to engage clutch. WARNING! Excessive throttle may cause loss of control and vehicle overturn.
Belt slippage from water or snow ingestion into the PVT system	Dry out the PVT (see page 93). Prevent water from entering the PVT outlet duct (see page 115). Inspect clutch seals for damage if repeated leaking occurs.
Clutch malfunction	See your dealer.
Poor engine performance	Check for fouled plugs or foreign material in gas tank or fuel lines. See your dealer.
Slippage from failure to warm up belt	Always warm up the belt by operating below 30 MPH (48 km/h) for one mile (1.5 km) and for 5 miles (8 km) or more when temperature is below freezing.
Wrong or missing belt	Install the recommended belt.
Improper break-in	Always break in a new belt and/or clutch. See page 50.
Failed belt	Remove the belt and clean away any debris from the clutch box, clutch duct and engine compartment. Install a new belt. WARNING! Failure to remove ALL debris when replacing the belt could result in vehicle damage and severe injury or death. See page 92.

TROUBLESHOOTING

Engine Doesn't Turn Over

Possible Cause	Solution
Low battery voltage	Recharge the battery to 12.8 VDC
Loose battery connections	Check all connections and tighten
Loose solenoid connections	Check all connections and tighten
Loose electronic control box connections	Inspect, clean, reinstall connectors
Mechanical failure	See your dealer

Engine Turns Over, Fails to Start

Possible Cause	Solution
Out of fuel	Refuel
Clogged fuel filter	See your dealer
Water is present in fuel	Drain the fuel system and refuel
Old or non-recommended fuel	Replace with fresh recommended fuel
Fouled or defective spark plugs	Inspect plugs and replace if necessary
No spark to spark plug	Inspect plugs and replace if necessary
Water or fuel in crankcase	Immediately see your dealer
Low battery voltage	Recharge the battery to 12.8 VDC
Loose ignition connections	Check all connections and tighten
Mechanical failure	See your dealer

Engine Backfires

Possible Cause	Solution
Out of fuel	Refuel
Weak spark from spark plug	Inspect, clean and/or replace spark plugs
Incorrect spark plug gap or heat range	Set gap to specs or replace plugs
Old or non-recommended fuel	Replace with fresh recommended fuel
Incorrectly installed spark plug wires	See your dealer
Incorrect ignition timing	See your dealer
Loose ignition connections	Check all connections and tighten
Water present in fuel	Replace with fresh recommended fuel
Exhaust leak	Check all connections
Mechanical failure	See your dealer

TROUBLESHOOTING

Engine Pings or Knocks

Possible Cause	Solution
Poor quality or low octane fuel	Replace with recommended fuel
Incorrect ignition timing	See your dealer
Incorrect spark plug gap or heat range	Set gap to specs or replace plugs

Engine Runs Irregularly, Stalls or Misfires

Possible Cause	Solution
Fouled or defective spark plugs	Inspect, clean and/or replace spark plugs
Worn or defective spark plug wires	See your dealer
Incorrect spark plug gap or heat range	Set gap to specs or replace plugs
Loose ignition connections	Check all connections and tighten
Water present in fuel	Replace with new fuel
Low battery voltage	Recharge battery to 12.8 VDC
Kinked or plugged fuel tank vent line or filter	Inspect and replace
Kinked idle air control lines	Inspect; rotate lines to remove kink
Incorrect fuel	Replace with recommended fuel
Clogged air filter	Inspect and clean or replace
Other mechanical failure	See your dealer

Possible Lean Fuel Cause	Solution
Low or contaminated fuel	Add or change fuel, clean the fuel system
Low octane fuel	Replace with recommended fuel
Clogged fuel filter	See your dealer
Low fuel pressure	See your dealer

TROUBLESHOOTING

Engine Stops or Loses Power

Possible Cause	Solution
Out of fuel	Refuel
Kinked or plugged fuel tank vent line or filter	Inspect and replace
Water is present in fuel	Replace with new fuel
Fouled or defective spark plugs	Inspect, clean and/or replace spark plug
Worn or defective spark plug wires	See your dealer
Incorrect spark plug gap or heat range	Set gap to specs or replace plug
Loose ignition connections	Check all connections and tighten
Low battery voltage	Recharge the battery to 12.8 VDC
Incorrect fuel	Replace with fresh recommended fuel
Clogged air filter	Inspect and clean or replace
Other mechanical failure	See your dealer
Overheated engine	Clean radiator screen and core, clean engine exterior, check coolant level, see your dealer if condition persists

WARRANTY

LIMITED WARRANTY

POLARIS Sales Inc., 2100 Highway 55, Medina, MN 55340, gives a SIX MONTH LIMITED WARRANTY on all components of your POLARIS vehicle against defects in material or workmanship. This warranty covers the parts and labor charges for repair or replacement of defective parts which are covered by this warranty. This warranty begins on the date of purchase. This warranty is transferable to another consumer during the warranty period through a POLARIS dealer.

REGISTRATION

At the time of sale, the Warranty Registration Form must be completed by your dealer and submitted to POLARIS within ten days. Upon receipt of this registration, POLARIS will record the registration for warranty. No verification of registration will be sent to the purchaser as the copy of the Warranty Registration Form will be the warranty entitlement. If you have not signed the original registration and received the customer copy, please contact your dealer immediately. **NO WARRANTY COVERAGE WILL BE ALLOWED UNLESS YOUR VEHICLE IS REGISTERED WITH POLARIS.**

Initial dealer preparation and set-up of your vehicle is very important in ensuring trouble-free operation. Purchasing a machine in the crate or without proper dealer set-up will void your warranty coverage.

WARRANTY

WARRANTY COVERAGE AND EXCLUSIONS: LIMITATIONS OF WARRANTIES AND REMEDIES

The POLARIS limited warranty excludes any failures that are not caused by a defect in material or workmanship. This warranty does not cover accidental damage, normal wear and tear, abuse or improper handling. This warranty also does not cover any vehicle that has been altered structurally, modified, neglected, improperly maintained, used for racing, or used for purposes other than for which it was manufactured, or for any damages which occur during trailer transit or as a result of unauthorized service or the use of unauthorized parts. In addition, this warranty does not cover physical damage to paint or finish, stress cracks, tearing or puncturing of upholstery material, corrosion, or defects in parts, components or the vehicle due to fire, explosions or any other cause beyond POLARIS' control.

Warranty does not apply to parts exposed to friction surfaces, stresses, environmental conditions and/or contamination for which they were not designed or not intended, including but not limited to the following items:

- Wheels and tires
- Suspension components
- Brake components
- Seat components
- Clutches and components
- Steering components
- Batteries
- Light bulbs/Sealed beam lamps
- Finished and unfinished surfaces
- Carburetor/Throttle body components
- Engine components
- Drive belts
- Hydraulic components
- Circuit breakers/Fuses
- Electronic components

Warranty applies to the product only and does not allow for coverage of personal loss. Some items are considered "consumable," meaning they are considered part of normal maintenance or part of completing an effective repair. The following items are excluded from warranty coverage in the event of a warranty claim:

- Spark Plugs
- Filters
- Fuel
- Sealants
- Hotel fees
- Towing charges
- Mileage
- Rentals/Loss of product use
- Lubricants such as oil, grease, etc.
- Batteries (unless defective)
- Cosmetic damage/repair
- Coolants
- Meals
- Shipping/ handling fees
- Product pick-up/delivery
- Loss of vacation/personal time

WARRANTY

LIMITATIONS OF WARRANTIES AND REMEDIES

This warranty also excludes failures resulting from improper lubrication; improper engine timing; improper fuel; surface imperfections caused by external stress, heat, cold or contamination; operator error or abuse; improper component alignment, tension, adjustment or altitude compensation; failure due to snow, water, dirt or other foreign substance ingestion/contamination; improper maintenance; modified components; use of aftermarket components resulting in failure; unauthorized repairs; repairs made after the warranty period expires or by an unauthorized repair center; use of the product in competition or for commercial purposes. Warranty will not apply to any product which has been damaged by abuse, accident, fire or any other casualty not determined a defect of materials or workmanship.

This warranty does not cover the use of unauthorized lubricants, chemicals, or fuels that are not compatible with the vehicle. The exclusive remedy for breach of this warranty shall be, at POLARIS' exclusive option, repair or replacement of any defective materials, or components or products. THE REMEDIES SET FORTH IN THIS WARRANTY ARE THE ONLY REMEDIES AVAILABLE TO ANY PERSON FOR BREACH OF THIS WARRANTY. POLARIS SHALL HAVE NO LIABILITY TO ANY PERSON FOR INCIDENTAL, CONSEQUENTIAL OR SPECIAL DAMAGES OF ANY DESCRIPTION, WHETHER ARISING OUT OF EXPRESS OR IMPLIED WARRANTY OR ANY OTHER CONTRACT, NEGLIGENCE, OR OTHER TORT OR OTHERWISE. THIS EXCLUSION OF CONSEQUENTIAL, INCIDENTAL, AND SPECIAL DAMAGES IS INDEPENDENT FROM AND SHALL SURVIVE ANY FINDING THAT THE EXCLUSIVE REMEDY FAILED OF ITS ESSENTIAL PURPOSE. Some states do not permit the exclusion or limitation of incidental or consequential damages or implied warranties, so the above limitations or exclusions may not apply to you if inconsistent with controlling state law.

ALL IMPLIED WARRANTIES (INCLUDING BUT NOT LIMITED TO THE IMPLIED WARRANTIES OF MERCHANTABILITY AND FITNESS FOR A PARTICULAR PURPOSE) ARE LIMITED IN DURATION TO THE ABOVE SIX MONTH WARRANTY PERIOD. POLARIS FURTHER DISCLAIMS ALL EXPRESS WARRANTIES NOT STATED IN THIS WARRANTY. Some states do not allow limitations on how long an implied warranty lasts, so the above limitation may not apply to you if inconsistent with controlling state law.

WARRANTY

HOW TO OBTAIN WARRANTY SERVICE

If your vehicle requires warranty service, you must take it to a POLARIS Servicing Dealer. When requesting warranty service you must present your copy of the Warranty Registration form to the dealer. (THE COST OF TRANSPORTATION TO AND FROM THE DEALER IS YOUR RESPONSIBILITY). POLARIS suggests that you use your original selling dealer; however, you may use any POLARIS Servicing Dealer to perform warranty service.

Please work with your dealer to resolve any warranty issues. Should your dealer require any additional assistance they will contact the appropriate person at POLARIS.

This warranty gives you specific legal rights, and you may also have other rights which vary from state to state.

If any of the above terms are void because of state or federal law, all other warranty terms will remain in effect.

Lubricants

1. Mixing oil brands or using non-recommended oil may cause engine damage. We recommend the use of POLARIS engine oil.
2. Damage resulting from the use of non-recommended lubricants may not be covered by warranty.

SPARK ARRESTER

POLARIS warrants that the spark arrester in this vehicle will meet the efficiency requirements of USFS standard 5100-1C for at least 1000 hours when subjected to normal use and when maintenance and installation are in accordance with POLARIS recommendations.

Exported Vehicles

EXCEPT WHERE SPECIFICALLY REQUIRED BY LAW, THERE IS NO WARRANTY OR SERVICE BULLETIN COVERAGE ON THIS VEHICLE IF IT IS SOLD OUTSIDE THE COUNTRY OF THE SELLING DEALER'S AUTHORIZED LOCATION.

This policy does not apply to vehicles that have received authorization for export from POLARIS Industries. Dealers may not give authorization for export. You should consult an authorized dealer to determine this vehicle's warranty or service bulletin coverage if you have any questions.

This policy does not apply to vehicles registered to government officials or military personnel on assignment outside the country of the selling dealer's authorized location.

This policy does not apply to Safety Bulletins.

How to Get Service

In the Country where your vehicle was purchased:

Warranty or Service Bulletin repairs must be done by an authorized POLARIS dealer. If you move or are traveling within the country where your vehicle was purchased, Warranty or Service Bulletin repairs may be requested from any authorized POLARIS dealer who sells the same line as your vehicle.

Outside the Country where your vehicle was purchased:

If you are traveling temporarily outside the country where your vehicle was purchased, you should take your vehicle to an authorized POLARIS dealer. You must show the dealer photo identification from the country of the selling dealer's authorized location as proof of residence. Upon residence verification, the servicing dealer will be authorized to perform the warranty repair.

If You Move:

If you move to another country, be sure to contact POLARIS Customer Assistance and the customs department of the destination country before you move. Vehicles importation rules vary considerably from country to country. You may be required to present documentation of your move to POLARIS Industries in order to continue your warranty coverage. You may also be required to obtain documentation from POLARIS Industries in order to register your vehicle in your new country. You should warranty register your vehicle at a local POLARIS dealer in your new country immediately after you move to continue your warranty coverage and to ensure that you receive safety information and notices regarding your vehicle.

WARRANTY

How to Get Service

If Purchased From A Private Party:

If you purchase a POLARIS product from a private citizen, to be kept and used outside of the country in which the vehicle was originally purchased, all warranty coverage will be denied. You must nonetheless warranty register your vehicle under your name and address with a local POLARIS dealer in your country to ensure that you receive safety information and notices regarding your vehicle.

Notice

If your vehicle is registered outside of the country where it was purchased, and you have not followed the procedure set out above, your vehicle will no longer be eligible for warranty or service bulletin coverage of any kind, other than *safety* bulletins. (Vehicles registered to Government officials or military personnel on assignment outside of the country where the vehicle was purchased will continue to be covered by the basic warranty.)

For questions call POLARIS Customer Assistance:

United States: 1-888-704-5290

Canada: 1-204-925-7100

WARRANTY

U.S.A. EPA Emissions Limited Warranty

This emissions limited warranty is in addition to the POLARIS standard limited warranty for your vehicle. POLARIS Industries Inc. warrants that at the time it is first purchased, this emissions-certified vehicle is designed, built and equipped so it conforms with applicable U.S. Environmental Protection Agency emission regulations. POLARIS warrants that the vehicle is free from defects in materials and workmanship that would cause it to fail to meet these regulations.

The warranty period for this emissions-certified vehicle starts on the date the vehicle is first purchased and continues for a period of 500 hours of engine operation, 5000 kilometers (3100 miles) of vehicle travel, or 30 calendar months from the date of purchase, whichever comes first.

This emissions limited warranty covers components whose failure increases the vehicle's regulated emissions, and it covers components of systems whose only purpose is to control emissions. Repairing or replacing other components not covered by this warranty is the responsibility of the vehicle owner. This emissions limited warranty does not cover components whose failure does not increase the vehicle's regulated emissions.

For exhaust emissions, emission-related components include any engine parts related to the following systems:

- Air-induction system
- Fuel system
- Ignition system
- Exhaust gas recirculation systems

The following parts are also considered emission-related components for exhaust emissions:

- Aftertreatment devices
- Crankcase ventilation valves
- Sensors
- Electronic control units

The following parts are considered emission-related components for evaporative emissions:

- Fuel Tank
- Fuel Cap
- Fuel Line
- Fuel Line Fittings
- Clamps*
- Pressure Relief Valves*
- Control Valves*
- Control Solenoids*
- Electronic Controls*
- Vacuum Control Diaphragms*
- Control Cables*
- Control Linkages*
- Purge Valves
- Vapor Hoses
- Liquid/Vapor Separator
- Carbon Canister
- Canister Mounting Brackets
- Carburetor Purge Port Connector

*As related to the evaporative emission control system.

WARRANTY

U.S.A. EPA Emissions Limited Warranty

The exclusive remedy for breach of this limited warranty shall be, at the exclusive option of POLARIS, repair or replacement of any defective materials, components or products. THE REMEDIES SET FORTH IN THIS LIMITED WARRANTY ARE THE ONLY REMEDIES AVAILABLE TO ANY PERSON FOR BREACH OF THIS WARRANTY. POLARIS SHALL HAVE NO LIABILITY TO ANY PERSON FOR INCIDENTAL, CONSEQUENTIAL OR SPECIAL DAMAGES OF ANY DESCRIPTION, WHETHER ARISING OUT OF EXPRESS OR IMPLIED WARRANTY OR ANY OTHER CONTRACT, NEGLIGENCE OR OTHER TORT OR OTHERWISE. THIS EXCLUSION OF CONSEQUENTIAL, INCIDENTAL, AND SPECIAL DAMAGES IS INDEPENDENT FROM AND SHALL SURVIVE ANY FINDING THAT THE EXCLUSIVE REMEDY FAILED OF ITS ESSENTIAL PURPOSE.

ALL IMPLIED WARRANTIES (INCLUDING BUT NOT LIMITED TO ANY IMPLIED WARRANTIES OF MERCHANTABILITY AND FITNESS FOR A PARTICULAR PURPOSE) ARE LIMITED IN DURATION TO THE WARRANTY PERIOD DESCRIBED HEREIN. POLARIS DISCLAIMS ALL EXPRESS WARRANTIES NOT STATED IN THIS WARRANTY. Some states do not allow limitations on how long an implied warranty lasts, so the above limitation may not apply if it is inconsistent with the controlling state law.

This limited warranty excludes failures not caused by a defect in material or workmanship. This limited warranty does not cover damage due to accidents, abuse or improper handling, maintenance or use. This limited warranty also does not cover any engine that has been structurally altered, or when the vehicle has been used in racing competition. This limited warranty also does not cover physical damage, corrosion or defects caused by fire, explosions or other similar causes beyond the control of POLARIS.

Owners are responsible for performing the scheduled maintenance identified in the owner's manual. POLARIS may deny warranty claims for failures that have been caused by the owner's or operator's improper maintenance or use, by accidents for which POLARIS has no responsibility, or by acts of God.

Any qualified repair shop or person may maintain, replace, or repair the emission control devices or systems on your vehicle. POLARIS recommends that you contact an authorized POLARIS dealer to perform any service that may be necessary for your vehicle. POLARIS also recommends that you use only Pure POLARIS parts. It is a potential violation of the Clean Air Act if a part supplied by an aftermarket parts manufacturer reduces the effectiveness of the vehicle's emission controls. Tampering with emission controls is prohibited by federal law.

If you have any questions regarding your warranty rights and responsibilities, please contact the POLARIS Warranty Department at 1-888-704-5290.

INDEX

A

Access Panel	
Cargo Box	35
Engine	35
Oil Tank	35
Accessory Outlets	30
Adjustments	
Hand Hold	33
Seat	32
Steering Wheel	32
Age Restrictions	10
Air Filter	95
Air Filter Cleaning	95
All Wheel Drive Switch	31
All Wheel Drive System	40
Arrestor, Spark, Warning	96-97
Auxiliary Outlets	30
AWD Switch	31, 40
AWD System	40
Axle Nut Torque	105

B

Battery	111-114
Charging	113-114
Installation	112
Removal	111
Storage	112
Before Riding	52
Belt Burning	125
Belt Life	67
Belt Replacement	92-93
Belt Wear	125
Belts, Seat	37
Boots	9
Brake Fluid	100
Brake Inspection	99
Brake Lights	107
Brake Pedal	39
Brake System Break-in	51
Brakes	99-100
Braking	54
Break-In Period	50-51
Burning Belts	125

C

Cab Frame, ROPS	39
Cab Nets	36
Cap, Fuel	36
Cargo	66-67
Cargo Box Access Panel	35
Changing Gears	38
Chart, Periodic Maintenance	69-73
Check Engine Indicator	49
Cleaning and Storage	115-119
Cleaning the Air Filter	95
Cleaning the Exhaust System	97
Cleaning the Spark Arrestor	97
Clothing	9
Clutching	121, 123
Component Locations	28-29
Condition, Spark Plugs	85
Coolant	
Level, Overflow Bottle	90
Level, Radiator	89
Adding	88
Changing	88-89
Replacing	89
Cooling Fan	88
Cooling System	89-90
Cooling System Operation	88
Cover for Storage	118
Crankcase Emission Control System	68

D

Demand Drive Fluid	82-83
Display Units, Standard/Metric	45
Drive Belt Wear	125
Drivetrain Break-In	51
Driving Downhill	61
Driving in Reverse	64
Driving on a Sidehill	61
Driving on Slippery Surfaces	59
Driving Over Obstacles	63
Driving Procedures	56-57
Driving Through Water	62
Driving Uphill	60
Driving with Passengers	58
Driving, After Driving in Water	93
Drying the Transmission	93

E

Electromagnetic Interference	68
Emission Control, Crankcase	68
Emission Control, Exhaust	68
Emission Control, Noise	68
Emissions Limited Warranty	135-136
Engaging AWD	40
Engine Access Panel	35
Engine Break-In	51
Engine Fogging	118
Engine Idle Speed	98
Engine Intake Pre-Filter	94
Engine Oil	76-79
Engine Starting	54
Engine Stopping	54
Equipment Modifications	7
Error Codes, Engine	49
Etiquette, Trail Riding	55
Exhaust Cleaning	97
Exhaust Emission Control System	68
Exhaust System Warning	96-97
Eye Protection	9

F

Fan, Cooling	88
Filter	
Air Filter	95
Care During Storage	117
Cleaning, Air	95
Fuel Tank Vent Filter	94
Systems	94-95
Fluid	
Demand Drive	82-83
Front Gearcase	82-83
Main Gearcase	80-81
Transmission	80-81
Fluid Change	
Demand Drive	83
Front Gearcase	83
Main Gearcase	81
Transmission	81
Fluid Check	
Demand Drive	82
Front Gearcase	82
Main Gearcase	80
Transmission	80

F

Fluid Levels During Storage	117
Fluid Recommendations, Gearcase	84
Fluid, Brake	100
Fogging the Engine	118
Fouled Plugs	85
Freeplay, Steering Wheel	110
Freeplay, Throttle	98
Fuel Cap	36
Fuel Safety	19
Fuel Stabilizer	117
Fuel Tank Filler Cap	36
Fuel Tank Vent Filter	94
Fuses	86-87

G

Gap, Spark Plug	84
Gasoline Handling	19
Gear Selector	38
Gearcase Capacities	84
Gearcase Oil	
Demand Drive	82-83
Front	82-83
Main	80-81
Gearcase Specifications	84
Gearcases	80-84
Demand Drive	82-83
Front Gearcase	82-83
Main Gearcase	80-81
Specification Chart	84
Transmission	80-81
Gears, shifting	38
Gloves	9

H

Hand Hold, Passenger	33
Hauling a Load	66-67
Hauling Cargo	66-67
Headlight Replacement	107
Headlight Switch	31
Helmet	8
Hood Removal	34

INDEX

I

Idle Speed	98
Ignition Switch.	30
Indicator Lamps	42
Inspection, Axle Nuts	105
Inspection, Brakes	99
Inspection, Pre-Ride	52
Inspection, Steering Wheel	110
Inspection, Wheel Nuts	105
Installation, Battery	112
Installation, Wheels	106
Instrument Cluster	41-49
Interference, Electromagnetic	68

K

Key, Periodic Maintenance Chart	70
---	----

L

Lights

Brake Lights	107
Headlight Beam Adjustment	108
Headlight Replacement	107
Headlight Switch	31
Low Beam Adjustment	108
Lubricant Part Numbers.	124
Lubrication for Storage	118
Lubrication Recommendations	74-75

M

Maintenance, Periodic	69-73
Metric Display	45
Mode Button	41

N

Nets, Cab	36
New Operator Procedures	56-57
Noise Emission Control System	68

O

Obstacles	63
---------------------	----

Oil

Demand Drive	82-83
Engine	76-79
Front Gearcase	82-83
Main Gearcase	80-81
Transmission	80-81

O

Oil and Filter Care During Storage	117
--	-----

Oil Change

Demand Drive	83
Engine	79
Engine Oil	78
Front Gearcase	83
Main Gearcase	81
Transmission	81

Oil Check

Demand Drive	82
Engine Oil	77
Front Gearcase	82
Main Gearcase	80
Transmission	80

Oil Recommendations	76
Oil Tank Access Panel.	35
Operation on Public Lands	68
Operation, Cooling System	88
Operation, Transmission	91-93
Operator Restrictions.	10
Outlets, Auxiliary	30
Overflow Bottle Coolant Level.	90

P

Parking on an Incline.	65
Parking the Vehicle	55
Passenger Hand Hold Adjustment.	33
Periodic Maintenance Chart	69-73
Plug Condition.	85
Plug Gap	84
Plug Torque	84
Plugs, Fouled	85
Plugs, Spark	84-85
Polaris Products	124
Polishing the Vehicle.	116
Pre-Filters, Intake	94
Pre-Ride Inspection	52
Public Lands	68
PVT Break-In	51
PVT Drying	93
PVT Intake Pre-Filter	94
PVT System Operation	91-93
PVT, Cleaning Debris	92-93

INDEX

R

Radiator	88
Radiator Coolant Level	89
Removing Vehicle from Storage	119
Restrictions, Age	10
Reverse	64
Rider Information Center	43-49
Riding Area	55
Riding Gear	8-9
Rollover Protective Structure	39
ROPS Cab Frame	39
RPM, Idle, Throttle Body	98

S

Safe Operation Practices	53
Safety Labels	20-27
Safety Symbols	4
Safety Training, ROHVA	1, 5, 53, 56
Safety Warnings	10-19
Seat Adjustment	32
Seat Belts	37
Seat Removal	32
Severe Use Definition	69
Shifting Gears	38
Shock Compression	104
Signal Words	4
Spark Arrester Warning	96-97
Spark Arrester Cleaning	97
Spark Plugs	84-85
Condition	85
Gap	84
Removal	85
Torque	84
Fouled	85
Specifications	120-123
Specifications, Gearcase	84
Speed, Idle	98
Speedometer	41
Spring Preload	101-103
Stabilizing the Fuel	117
Starting the Engine	54
Steering Wheel Adjustment	32
Steering Wheel Inspection	110

S

Stopping the Engine	54
Storage	115-119
Inspection	118
Lubrication	118
Area	118
Battery	112
Covers	118
Fluid Levels	117
Oil and Filter	117
Removal	119
Suspension Settings	101-104
Switches	
AWD Switch	31, 40
Ignition Switch	30
Mode Button	41

T

Tachometer	47
Throttle Freeplay	98
Throttle Pedal	39
Throttle System	98
Tire Tread Depth	105
Tires	105-106
Trail Etiquette	55
Transmission Oil	80-81
Transmission Operation	91-93
Transmission, Drying	93
Transporting the Vehicle	119
Tread Depth, Tire	105
Tread Lightly	55

V

Vehicle Identification Numbers	6
Vehicle Immersion	109
Vehicle Transport	119

W

Warning Symbols	4
Washing the Vehicle	115-116
Wheel Installation	106
Wheel Nut Torque	105
Wheel Removal	106



The text is printed on 100% recycled
with 40% post-consumer waste (PCW).

WARNING

Improper vehicle use can result in SEVERE INJURY or DEATH

NEVER Operate:

- without first viewing safety video and quick start guide.
- with more than one passenger in a 2-seat vehicle.
- with more than three passengers in a 4-seat vehicle.
- on hills steeper than 15 degrees.
- on public roads.
- on paved surfaces - pavement may seriously affect handling and control.
- with non-Polaris approved accessories - they may seriously affect stability.

ALWAYS:

- keep hands and feet inside vehicle. Use the cab nets.
- reduce speed and use extra caution when carrying passengers.
- operate slowly in reverse - avoid sharp turns or sudden braking.
- make sure passengers read and understand all safety labels.
- avoid branches or other hazards that could enter vehicle.



ALWAYS USE AN APPROVED HELMET AND PROTECTIVE GEAR FOR OPERATOR AND PASSENGERS. NEVER USE ON PUBLIC ROADS. NEVER USE WITH DRUGS OR ALCOHOL.

READ OWNER'S MANUAL. FOLLOW ALL INSTRUCTIONS AND WARNINGS.



POLARIS
The Way Out.

For your nearest Polaris dealer,
call 1-800-POLARIS
or visit www.polarisindustries.com

Polaris Sales Inc.,
2100 Hwy. 55
Medina, MN 55340
Phone 1-888-704-5290

Part No. 9923625 Rev 01
Printed in USA

