

POLARIS[®]



SCRAMBLER[®] 850 XP
SCRAMBLER[®] 850 XP EPS

Owner's Manual
for Maintenance and Safety

Read this manual carefully. It contains important safety information.

This is an adult vehicle only.

Operation is prohibited for those under 16 years of age.

⚠ WARNING

The engine exhaust from this product contains chemicals known to the State of California to cause cancer, birth defects or other reproductive harm.

A card containing important ATV safety information should be attached to the owner's manual on the next page. If you cannot locate this card, or if it has been removed, please call 1-800-342-3764 for assistance.



The text is printed on 100% recycled
with 40% post-consumer waste (PCW).

WARNING

Improper vehicle use can result in **SEVERE INJURY** or **DEATH**.



**ALWAYS USE
AN APPROVED
HELMET AND
PROTECTIVE
GEAR**



**NEVER USE
ON PUBLIC
ROADS**



**NEVER CARRY
PASSENGERS**



**NEVER USE
WITH DRUGS
OR ALCOHOL**

NEVER operate:

- **without proper training or instruction.**
- **at speeds too fast for your skills or the conditions.**
- **on public roads - a collision can occur with another vehicle.**
- **with a passenger - passengers affect balance and steering and increase risk of losing control.**

ALWAYS:

- **use proper riding techniques to avoid vehicle overturns on hills and rough terrain and in turns.**
- **avoid paved surfaces - pavement may seriously affect handling and control.**

READ OWNER'S MANUAL.

FOLLOW ALL INSTRUCTIONS AND WARNINGS.



POLARIS®

For your nearest Polaris dealer,
call 1-800-POLARIS
or visit www.polarisindustries.com
Polaris Sales Inc.,
2100 Hwy. 55, Medina, MN 55340
Phone 1-888-704-5290
Part No. 9923805 Rev 01
Printed in USA



WELCOME

Thank you for purchasing a POLARIS vehicle, and welcome to our world-wide family of POLARIS enthusiasts. Be sure to visit us online at www.polarisindustries.com for the latest news, new product introductions, upcoming events, career opportunities and more.

Here at POLARIS we proudly produce an exciting line of utility and recreational products.

- Snowmobiles
- All-terrain vehicles (ATVs)
- *RANGER*® utility vehicles
- Victory Motorcycles®
- Low emission vehicles (LEVs)

We believe POLARIS sets a standard of excellence for all utility and recreational vehicles manufactured in the world today. Many years of experience have gone into the engineering, design, and development of your POLARIS vehicle.

For safe and enjoyable operation of your vehicle, be sure to follow the instructions and recommendations in this owner's manual. Your manual contains instructions for minor maintenance, but information about major repairs is outlined in the POLARIS Service Manual and should be performed only by a factory certified Master Service Dealer® (MSD) technician.

Your POLARIS dealer knows your vehicle best and is interested in your total satisfaction. Be sure to return to your dealership for all of your service needs during, and after, the warranty period.



POLARIS®

POLARIS and SCRAMBLER are registered trademarks of POLARIS Industries Inc. Copyright 2012 POLARIS Sales Inc. All information contained within this publication is based on the latest product information at the time of publication. Due to constant improvements in the design and quality of production components, some minor discrepancies may result between the actual vehicle and the information presented in this publication. Depictions and/or procedures in this publication are intended for reference use only. No liability can be accepted for omissions or inaccuracies. Any reprinting or reuse of the depictions and/or procedures contained within, whether whole or in part, is expressly prohibited.

The original instructions for this vehicle are in English. Other languages are provided as translations of the original instructions.

Printed in U.S.A.

2013 SCRAMBLER 850 XP / SCRAMBLER 850 XP EPS Owner's Manual
P/N 9923805

TABLE OF CONTENTS

Introduction	4
Safety	7
Features and Controls	24
Operation	52
Emission Control Systems	71
Maintenance	72
Troubleshooting	117
POLARIS Products	121
Specifications	122
Warranty	124
Maintenance Log	132
Index	134

INTRODUCTION

The following signal words and symbols appear throughout this manual and on your vehicle. Your safety is involved when these words and symbols are used. Become familiar with their meanings before reading the manual.



The safety alert symbol indicates a potential personal injury hazard.

DANGER

A DANGER indicates a hazardous situation that, if not avoided, will result in death or serious injury.

WARNING

A WARNING indicates a hazardous situation that, if not avoided, could result in death or serious injury.

CAUTION

A CAUTION indicates a hazardous situation that, if not avoided, could result in minor or moderate injury.

NOTICE

A NOTICE indicates a situation that could result in property damage.



The Prohibition Safety Sign indicates an action NOT to take in order to avoid a hazard.



The Mandatory Action Sign indicates an action that NEEDS to be taken to avoid a hazard.

WARNING

Failure to heed the warnings and safety precautions contained in this manual can result in severe injury or death. A POLARIS ATV is not a toy and can be hazardous to operate. This vehicle handles differently than other vehicles, such as motorcycles and cars. A collision or rollover can occur quickly, even during routine maneuvers like turning, or driving on hills or over obstacles, if you fail to take proper precautions.

- Read this owner's manual. Understand all safety warnings, precautions and operating procedures before operating a POLARIS ATV. Keep this manual with the ATV.
- Never operate an ATV without proper instruction. Take a training course.
- This vehicle is an **ADULT VEHICLE ONLY**. Operation is prohibited for anyone under 16 years of age.
- Never permit a guest to operate the ATV unless the guest has read this manual and all product labels and has completed a certified safety training course.

European Vibration and Noise

The driver-perceived noise and hand/arm and whole body vibration levels of this machinery is measured per prEN 15997.

The operating conditions of the machinery during testing:

The vehicles were in like-new condition. The environment was controlled as indicated by the test procedure(s).

The uncertainty of vibration exposure measurement is dependent on many factors, including:

- Instrument and calibration uncertainty
- Variations in the machine such as wear of components
- Variation of machine operators such as experience or physique
- Ability of the worker to reproduce typical work during measurements
- Environmental factors such as ambient noise or temperature

INTRODUCTION

Vehicle Identification Numbers

Record your vehicle's identification numbers and key number in the spaces provided. Remove the spare key and store it in a safe place. An ignition key can be duplicated only by ordering a POLARIS key blank (using your key number) and mating it with one of your existing keys. The ignition switch must be replaced if all keys are lost.

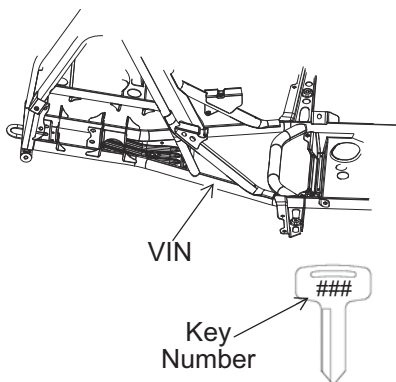

Engine Serial Number

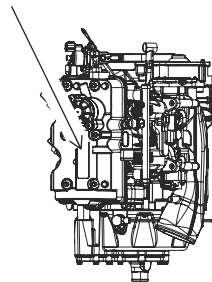

Vehicle Model Number: _____

Frame VIN: _____

Engine Serial Number: _____

Key Number: _____

Safety Training

ATV safety training is a top priority for POLARIS. POLARIS strongly encourages you and any family members who will be riding the ATV to take a training course.

If you purchased a new POLARIS ATV in the United States, your dealer provided information about the authorized ATV *RiderCourse*sm that is available to you and your eligible family members. This training is included in the purchase price of your ATV. You were also provided with printed materials that explain safe operating procedures. You should review this information on a regular basis.

If you purchased a used POLARIS ATV in the United States, you can enroll in the ATV *RiderCourse*sm for a fee. Call ATV Enrollment Express at (800) 887-2887 or visit www.atvsafety.org.

If you purchased a POLARIS ATV outside the United States, please contact your dealer or local law enforcement agencies for information about safety training.

A POLARIS ATV is an off-road vehicle. Familiarize yourself with all laws and regulations concerning the operation of this vehicle in your area.

We strongly advise you to strictly follow the recommended maintenance program outlined in your owner's manual. This preventive maintenance program is designed to ensure that all critical components on your vehicle are thoroughly inspected at specific intervals.

FOR MORE INFORMATION ABOUT ATV SAFETY in the United States, call the Consumer Product Safety Commission at 1-800-638-2772, or visit www.cpsc.gov, visit www.atvsafety.org, or call POLARIS at 1-800-342-3764.

SAFETY

Safe Riding Gear

Always wear appropriate clothing when riding an ATV. Wear protective clothing for comfort and to reduce the chance of injury.

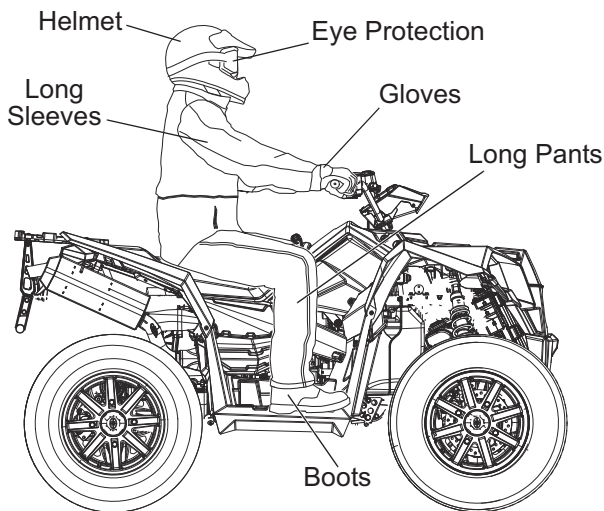

Helmet

Wearing a helmet can prevent a severe head injury. Whenever riding a POLARIS vehicle, always wear a helmet that meets or exceeds established safety standards.

Approved helmets in the USA and Canada bear a U.S. Department of Transportation (DOT) label.

Approved helmets in Europe, Asia and Oceania bear the ECE 22.05 label. The ECE mark consists of a circle surrounding the letter E, followed by the distinguishing number of the country which has granted approval. The approval number and serial number will also be displayed on the label.

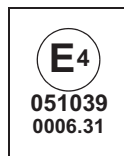

Safe Riding Gear

Eye Protection

Do not depend on eyeglasses or sunglasses for eye protection. Whenever riding a POLARIS vehicle, always wear shatterproof goggles or use a shatterproof helmet face shield. POLARIS recommends wearing approved Personal Protective Equipment (PPE) bearing markings such as VESC 8, V-8, Z87.1, or CE. Make sure protective eye wear is kept clean.

Gloves

Off-road style gloves with knuckle pads are the best for comfort and protection.

Boots

The best footwear is a pair of sturdy over-the-calf boots with low heels.

Clothing

Always wear long sleeves and long pants to protect arms and legs. Riding pants with kneepads and a jersey with shoulder pads provide the best protection.

Equipment Modifications

We strongly recommend that consumers do not install on a POLARIS ATV any equipment that may increase the speed or power of the vehicle, or make any other modifications to the vehicle for these purposes.

The warranty on your POLARIS ATV is terminated if any equipment has been added to the vehicle, or if any modifications have been made to the vehicle, that increase its speed or power.

The addition of certain accessories, including (but not limited to) mowers, blades, tires, sprayers, or large racks, may change the handling characteristics of the vehicle. Use only POLARIS-approved accessories, and familiarize yourself with their function and effect on the vehicle.

SAFETY

Safety Warnings

⚠ WARNING

Failure to operate the ATV properly can result in a collision, loss of control, accident or overturn, which may result in serious injury or death. Heed all safety warnings outlined in this section of the owner's manual. See the OPERATION section of the owner's manual for proper operating procedures.

Operating Without Instruction

Operating this ATV without proper instruction increases the risk of an accident. The operator must understand how to operate the ATV properly in different situations and on different types of terrain.

Beginning and inexperienced operators should complete the recommended safety training before operating this vehicle. See page 7.

Never permit a guest to operate the ATV unless the guest has read this manual and all product labels and has completed a certified safety training course.

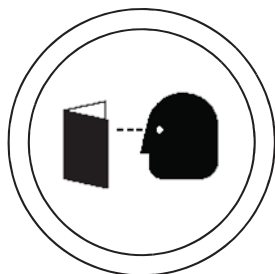

Age Restrictions

This vehicle is an **ADULT VEHICLE ONLY**. Operation is prohibited for anyone under 16 years of age.

Even though a child may be within the recommended age group for operating some ATVs, he/she may not have the skills, abilities, or judgment needed to operate an ATV safely and could be susceptible to accident or injury.



Failure to Inspect Before Operating

Failure to inspect and verify that the ATV is in safe operating condition before operating increases the risk of an accident.

Always inspect the ATV before each use to make sure it's in safe operating condition.

Always follow all inspection and maintenance procedures and schedules described in the owner's manual.

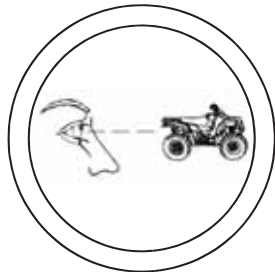

Safety Warnings

Handling Gasoline

Gasoline is highly flammable and explosive under certain conditions.

- Always exercise extreme caution whenever handling gasoline.
- Always refuel with the engine stopped, and outdoors or in a well ventilated area.
- Do not smoke or allow open flames or sparks in or near the area where refueling is performed or where gasoline is stored.
- Do not overfill the tank. Do not fill the tank neck.
- If gasoline spills on your skin or clothing, immediately wash it off with soap and water and change clothing.

Exposure to Exhaust

Engine exhaust fumes are poisonous and can cause loss of consciousness or death in a short time. Never start the engine or let it run in an enclosed area.

The engine exhaust from this product contains chemicals known to cause cancer, birth defects or other reproductive harm. Operate this vehicle only outdoors or in well-ventilated areas.

Protective Apparel

Riding in this vehicle without wearing an approved helmet and protective eyewear increases the risk of a serious injuries in the event of an accident.

Always wear an approved helmet that fits properly and eye protection (goggles or face shield).

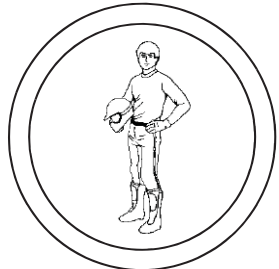

Using Alcohol or Drugs

Operating the ATV after consuming alcohol or drugs could adversely affect operator judgment, reaction time, balance and perception.

Never consume alcohol or drugs before or while operating an ATV.



SAFETY

Safety Warnings

Carrying a Passenger

Carrying a passenger greatly reduces the operator's ability to balance and control the ATV, which may result in an accident or overturn.

Never carry a passenger on this ATV.



Operating on Pavement

Operating an ATV on paved surfaces (including sidewalks, paths, parking lots and driveways) may adversely affect the handling of the ATV and could result in loss of control and accident or overturn.

Avoid operating the ATV on pavement. ATV tires are designed for off-road use. If it's unavoidable, travel slowly and avoid sudden turns or stops.



Operating on Public Roads

Operating this ATV on public streets, roads or highways could result in a collision with another vehicle.

Never operate the ATV on any public street, road or highway, including dirt and gravel roads. In many regions it's unlawful to operate ATVs on public streets, roads and highways.



Operating at Excessive Speeds

Operating the ATV at excessive speeds increases the operator's risk of losing control.

Always operate at a speed that's appropriate for the terrain, the visibility and operating conditions, and your experience.



Safety Warnings

Physical Control of the ATV

Removing a hand from the handlebars or feet from the footrests during operation can reduce your ability to control the vehicle or cause loss of balance and ejection from the ATV. If the operator's foot is not firmly planted on the footrest, it could also contact the rear wheels.

Never remove your hands from the handlebars while operating, and always keep both feet on the footrests.



Turning Improperly

Turning improperly could cause loss of traction, loss of control, accident or overturn.

Always follow proper procedures for turning as described in the owner's manual.

Never turn abruptly or at sharp angles. Never turn at high speeds. Practice turning at slow speeds before attempting to turn at faster speeds.



Jumps and Stunts

Attempting wheelies, jumps and other stunts increases the risk of an accident or overturn.

Never attempt wheelies, jumps, or other stunts. Avoid exhibition driving.



Improper Hill Climbing

Improper hill climbing could cause loss of control or overturn. Always follow proper procedures for climbing hills as described in the owner's manual. See page 61.

SAFETY

Safety Warnings

Descending Hills Improperly

Improperly descending a hill could cause loss of control or overturn.

- Always follow proper procedures for traveling down hills as described in the owner's manual. **NOTE:** A special technique is required when braking while traveling downhill. See page 63.
- Always descend a hill with the transmission in forward gear. Do not descend a hill with the transmission in neutral.
- Always check the terrain carefully before descending a hill.
- Shift your weight rearward.
- Never travel down a hill at high speed.
- Avoid traveling down a hill at an angle, which would cause the vehicle to lean sharply to one side. Travel straight down the hill when possible.

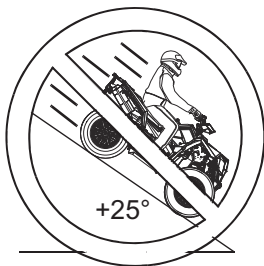

Crossing Hillside

Driving on a sidehill is not recommended. Improper procedure could cause loss of control or overturn. Avoid crossing the side of any hill unless absolutely necessary.

If crossing a hillside is unavoidable, always follow proper procedures as described in the owner's manual. See page 62.

Never attempt to turn the ATV around on any hill until you've mastered the turning technique (on level ground) as described in the owner's manual. See page 64.



Safety Warnings

Stalling While Climbing a Hill

Stalling, rolling backwards or improperly dismounting while climbing a hill could cause an overturn.

- Always maintain a steady speed when climbing a hill.

If all forward speed is lost:

- Keep body weight uphill.
- Apply the brakes.
- Lock the parking brake when fully stopped.
- Dismount on uphill side, or to either side if ATV is pointed straight uphill.
- Turn the ATV around and remount, following the procedure described in the owner's manual. See page 64.

If the ATV begins rolling downhill:

- Keep body weight uphill.
- Never apply engine power.
- Never apply the rear brake while rolling backwards. Apply the single-lever brake gradually.
- When fully stopped, apply the rear brake as well, and then lock the parking brake.
- Dismount on uphill side, or to either side if ATV is pointed straight uphill.
- Turn the ATV around and remount, following the procedure described in the owner's manual. See page 64.



Operating on Steep Hills

Operating on excessively steep hills could cause an overturn.

Never operate on hills too steep for the ATV or for your abilities. Never operate the ATV on hills steeper than 25 degrees.



SAFETY

Safety Warnings

Operating in Unfamiliar Terrain

Failure to use extra caution when operating on unfamiliar terrain could result in an accident or overturn.

Unfamiliar terrain may contain hidden rocks, bumps, or holes that could cause loss of control or overturn.

Travel slowly and use extra caution when operating on unfamiliar terrain. Always be alert to changing terrain conditions.



Operating on Slippery Terrain

Failure to use extra caution when operating on excessively rough, slippery or loose terrain could cause loss of traction, loss of control, accident or overturn.

Do not operate on excessively rough, slippery or loose terrain. Always use extra caution on rough, slippery or loose terrain.



Operating Improperly in Reverse

Improperly operating in reverse could result in a collision with an obstacle or person. Always follow proper operating procedures as outlined in this manual. See page 67.

Before shifting into reverse gear, always check for obstacles or people behind the ATV. When it's safe to proceed, back slowly.

Improper Tire Maintenance

Operating this ATV with improper tires or with improper or uneven tire pressure could cause loss of control or accident.

Always use the size and type of tires specified for your ATV.

Always maintain proper tire pressure as described in the owner's manual and on safety labels.



Safety Warnings

Operating Over Obstacles

Improperly operating over obstacles could cause loss of control or overturn.

Before operating in a new area, check for obstacles. Avoid operating over large obstacles such as rocks and fallen trees. If unavoidable, use extreme caution and always follow proper operating procedures as outlined in this manual. See page 66.

Skidding or Sliding

Skidding or sliding can cause loss of control or overturn (if tires regain traction unexpectedly).

On slippery surfaces such as ice or loose gravel, travel slowly and use extra caution to reduce the chance of skidding or sliding. Do not operate on excessively slippery surfaces.

Operating Through Deep Water

Operating the ATV through deep or fast-flowing water could cause the tires to float, causing loss of control or overturn.

Avoid operating the ATV through deep or fast-flowing water. If it's unavoidable to enter water that exceeds the recommended maximum depth (see page 65):

- Travel slowly.
- Balance your weight carefully.
- Avoid sudden movements.
- Maintain a slow and steady forward motion. Do not make sudden turns or stops, and do not make sudden throttle changes.
- Wet brakes may have reduced stopping ability. After leaving water, test the brakes. Apply them lightly several times while driving slowly. The friction will help dry out the pads.



SAFETY

Safety Warnings

Improper Cargo Loading

Overloading the ATV or carrying/towing cargo improperly may cause changes in handling, which could cause loss of control or an accident.

- Never exceed the stated load capacity for this ATV.
- Cargo should be properly distributed and securely attached.
- Reduce speed when carrying cargo or pulling a trailer. Allow a greater distance for braking.
- Always follow the instructions in the owner's manual for carrying cargo or pulling a trailer. See pages 68-69.

Operating on Frozen Bodies of Water

Operating on frozen bodies of water may result in serious injury or death if the ATV and/or the operator fall through the ice.

Never operate the ATV on a frozen body of water unless you have independently verified that the ice is sufficiently thick to support the weight and moving force of the ATV, you and your cargo, together with any other vehicles in your party. Variances in snow depth and/or water currents may result in uneven ice thickness. Always check with local authorities and residents to confirm ice conditions and thickness over your entire route. ATV operators assume all risk associated with ice conditions on frozen bodies of water.

Poor Visibility

Operating the ATV in darkness or inclement weather could result in a collision or accident, especially if operating on a road or street. This ATV is not equipped with highway-approved lights. Operate this vehicle off-road only. Use caution and drive at reduced speeds in conditions of reduced visibility such as fog, rain and darkness. Clean headlights frequently and replace burned out headlamps promptly.

Safety Warnings

Operating a Damaged ATV

Operating a damaged ATV can result in an accident. After any overturn or accident, have a qualified service dealer inspect the entire machine for possible damage, including (but not limited to) brakes, throttle and steering systems.

Physical Skills

Safe operation of this rider-active vehicle requires good judgement and physical skills. Persons with cognitive or physical disabilities who operate this vehicle have an increased risk of overturn and loss of control.

Hot Exhaust Systems

Exhaust system components are very hot during and after use of the vehicle. Hot components can cause burns and fire. Do not touch hot exhaust system components. Always keep combustible materials away from the exhaust system. Use caution when traveling through tall grass, especially dry grass.

Unauthorized Use of the ATV

Leaving the keys in the ignition can lead to unauthorized use of the vehicle, which could result in an accident or overturn. Always remove the ignition key when the vehicle is not in use.

SAFETY

Safety Labels and Locations

Warning labels have been placed on the vehicle for your protection. Read and follow the instructions on each label carefully. If any of the labels shown in this manual differ from the labels on your vehicle, always read and follow the instructions of the labels on the vehicle.

If an informational or graphic label becomes illegible or comes off, contact your POLARIS dealer to purchase a replacement. Replacement *safety* labels are provided by POLARIS at no charge. The part number is printed on the label.

General Warning

WARNING

Improper ATV use can result in SEVERE INJURY or DEATH
ALWAYS USE AN APPROVED HELMET AND PROTECTIVE GEAR
NEVER USE ON PUBLIC ROADS
NEVER CARRY PASSENGERS
NEVER USE WITH DRUGS OR ALCOHOL

NEVER operate:

- without proper training or instruction
- at speeds too fast for your skills or the conditions
- on public roads - a collision can occur with another vehicle
- with a passenger - passengers affect balance and steering and increase risk of losing control

ALWAYS:

- use proper riding techniques to avoid vehicle overturns on hills and rough terrain and in turns
- avoid paved surfaces - pavement may seriously affect handling and control

LOCATE AND READ OWNER'S MANUAL.

FOLLOW ALL INSTRUCTIONS AND WARNINGS.

7175376

Age 16 Warning

WARNING

Operating this ATV if you are under the age of 16 increases your chance of severe injury or death.

NEVER operate this ATV if you are under age 16.

7175374

Safety Labels and Locations

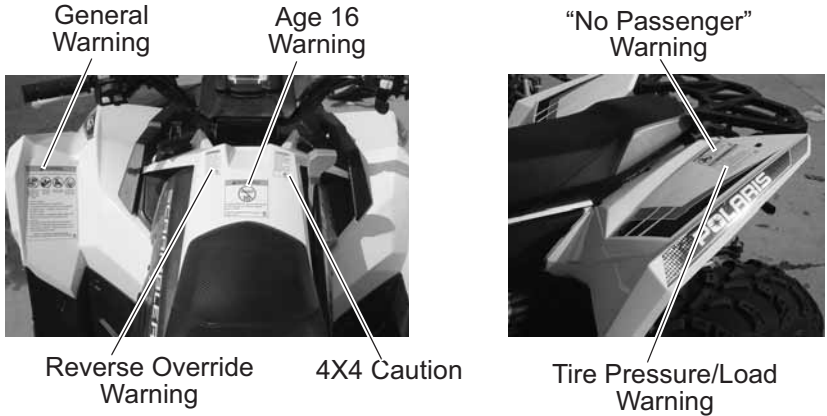

"No Passenger" Warning

WARNING

NEVER ride as a passenger.

Passengers can cause a loss of control, resulting in SEVERE INJURY or DEATH.

7175378

4X4 Caution

CAUTION

Do not push switch to engage 4X4 (AWD) if the rear wheels are spinning. This may cause severe drive shaft and clutch damage.

7175485

Tire Pressure/Load Warning

WARNING

Improper tire pressure or overloading can cause loss of control.

Loss of control can result in severe injury or death.

- Cold tire pressure:
Front: 7.0 psi (48.3 kPa) Rear: 7.0 psi (48.3 kPa)
- Maximum weight capacity: 290 lbs. (131 kg)
- Lug nut torque values:
Steel rims 45 ft-lbs. (61 Nm) Aluminum rims 75 ft-lbs. (102 Nm)

7179107

Reverse Override Warning

WARNING

Improper use of the override button can lead to loss of control resulting in severe injury or death. Do not activate override while throttle is engaged. Always apply throttle gradually, while in reverse.

7175486

SAFETY

Safety Labels and Locations

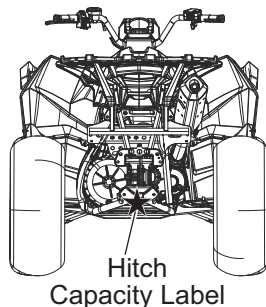
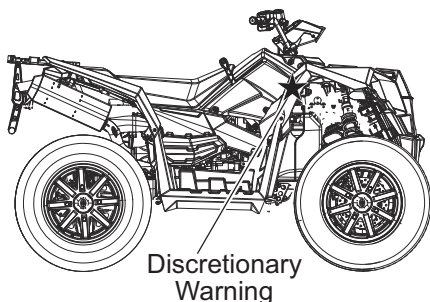

Discretionary Warning

WARNING

- Never operate this ATV on HILLS steeper than 25 degrees \leq 25°. To prevent overturn on hilly terrain, use throttle and brakes gradually, and shift weight uphill.
- REVERSE operation can be dangerous even at low speeds. Steering becomes difficult. To prevent loss of control, avoid sudden braking or sharp turns.

7179079

Hitch Capacity Label

TRAILER MAX WEIGHT:

1500 LBS. (682 KG) ON LEVEL GROUND

850 LBS. (386 KG) UP TO 15° GRADE

HITCH MAX. VERTICAL WEIGHT: 150 LBS. (68 KG)

7170509

Safety Labels and Locations

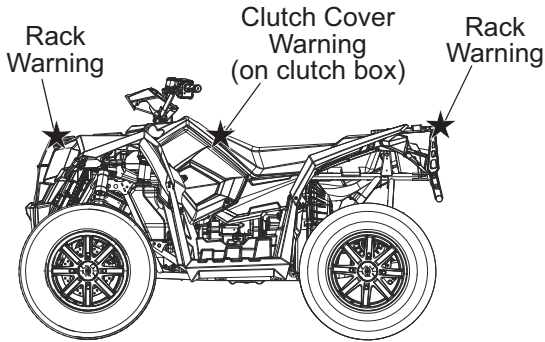

Clutch Cover Warning

WARNING

- Moving parts hazard under belt-clutch guard. To prevent serious injury, do not operate vehicle with guard removed.
- Do not modify engine or clutch. Doing so can cause part failure, possible imbalance, and excessive engine RPM, which can result in serious injury or death.

7175488

Rack Warning, Front and Rear

WARNING

- DO NOT TOW FROM RACK OR BUMPER. Vehicle damage or tipover may result causing severe injury or death. Tow only from tow hooks or hitch.
- Max. Rack Loads: Front 25 lbs. (11 kg) Rear 50 lbs. (23 kg)

7179093

FEATURES AND CONTROLS

Switches

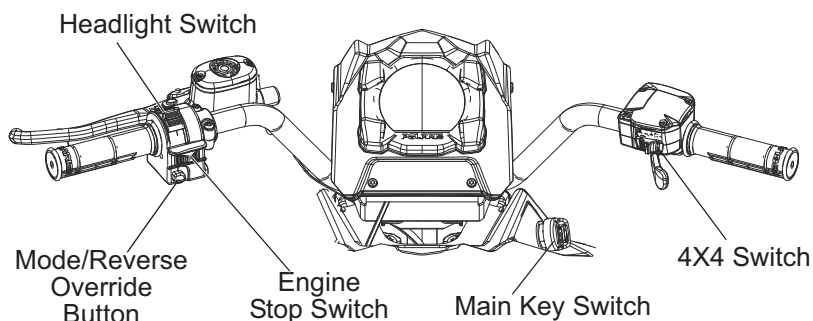

Mode/Reverse Override Switch

This vehicle is equipped with a reverse speed limiter system. To gain additional wheel speed while backing, release the throttle and depress the override button.

WARNING! Pressing the override button while the throttle is open can cause loss of control, which may result in serious injury or death. Always release the throttle before pressing the override button.

The reverse override button also acts as a MODE button when held down for approximately one half second. See the instrument cluster information beginning on page 34. The transmission cannot be in reverse when using the override button as a MODE button.

4X4 Switch

Use the 4X4 switch to engage 4X4 or 2X4. See page 32.

Headlight Switch

Use the headlight switch to turn the lights on and off and to change the lights from high beam to low beam. The key must be in the ON position and the engine stop switch must be in the RUN position to operate the headlights.

FEATURES AND CONTROLS

Switches

Engine Stop Switch

Move the stop switch either left or right to the OFF position to stop the engine quickly. Move the stop switch to the RUN position before attempting to start the engine. The engine will not start or run when the switch is off.

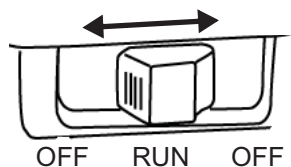

Both the main switch and the engine stop switch will shut off all electrical power to the vehicle, including lights.

Main Key Switch

Use the main key switch to start the engine. See page 57 for starting procedures.

Automatic Transmission Gear Selector

The transmission gear selector is located on the right side of the vehicle.

H: High Gear

L: Low Gear

N: Neutral

R: Reverse

P: Park

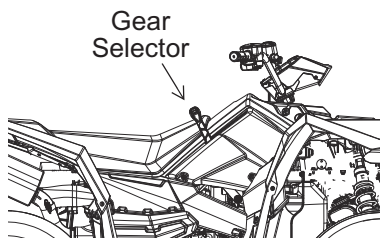

To shift gears, brake to a complete stop. When the engine is idling, move the lever to the desired gear.

NOTICE: Shifting gears with the engine speed above idle or while the vehicle is moving could cause transmission damage.

Whenever the ATV is left unattended, always place the transmission in PARK and lock the parking brake.

Belt Life

To extend belt life, use low forward gear when pulling a heavy load at less than seven miles per hour for extended periods and when operating uphill at a slow speed.

FEATURES AND CONTROLS

Throttle Lever

⚠ WARNING

Operating an ATV with sticking or improperly operating throttle controls could cause an accident. Never start or operate an ATV that has a sticking or improperly operating throttle. Always contact your dealer for service before operating the vehicle.

Failure to check or maintain proper operation of the throttle system can result in an accident if the throttle lever sticks during operation. Always check the lever for free movement and return before starting the engine. Also check occasionally during operation.

Modifications to the throttle release switch could result in failure to perform as designed, which could result in an accident. Do not attempt to modify the throttle release switch or replace it with any after market throttle mechanisms. Always ensure that the throttle cable is installed and properly routed to the throttle release switch.

Engine speed and vehicle movement are controlled by pressing the throttle lever. The throttle lever is spring loaded. Engine speed returns to idle when the lever is released.

This ATV is equipped with a throttle release switch, which is designed to reduce the risk of a frozen or stuck throttle. If the throttle cable should stick in an open position when the operator releases the throttle lever, engine speed will be limited, and power to the rear wheels will be reduced.

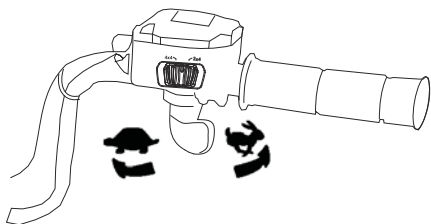

FEATURES AND CONTROLS

Brake Lever

▲ WARNING

Operating the ATV with a spongy brake lever can result in loss of braking, which could cause an accident. Never operate the ATV with a spongy-feeling brake lever. Always contact your dealer for service before operating the vehicle.

Squeeze the brake lever toward the handlebar to apply the front and rear brakes. These brakes are hydraulically activated disc type brakes that are activated by only one lever.

Always test brake lever travel and master cylinder fluid level before riding. When squeezed, the lever should feel firm. Any sponginess would indicate a possible fluid leak or low master cylinder fluid level, which must be corrected before riding. Contact your dealer for proper diagnosis and repairs.

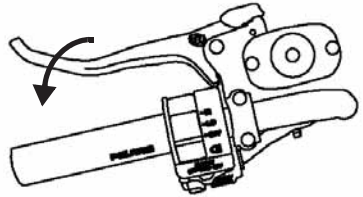

FEATURES AND CONTROLS

Master Cylinder/Brake Fluid

⚠ WARNING

An over-full master cylinder may cause brake drag or brake lock-up, which could result in an accident. Maintain brake fluid at the recommended level. Do not overfill.

Never store or use a partial bottle of brake fluid. Brake fluid is hygroscopic, meaning it rapidly absorbs moisture from the air. The moisture causes the boiling temperature of the brake fluid to drop, which can lead to early brake fade and the possibility of brake failure, which could result in an accident. After opening a bottle of brake fluid, always discard any unused portion.

Check the brake fluid in the master cylinder before each ride.

1. Position the ATV on a level surface.
2. Position the handlebars so the master cylinder is level.
3. View the brake fluid level through the indicator window on the top of the master cylinder. The eye will appear dark when the fluid level is full. When fluid is low, the eye will be clear.
4. If the fluid level is low, remove the cover screws and add fluid to the fill line. *Do not overfill*. Use DOT 4 brake fluid only.
5. Reinstall the cover. Torque screws to 7 in. lbs. (.8 Nm).

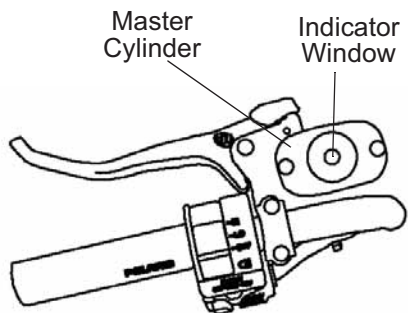

FEATURES AND CONTROLS

Parking Brake

Locking the Parking Brake

1. Place the transmission in PARK.
2. Squeeze and release the brake lever two or three times, then squeeze and hold.
3. Push the parking brake lock forward to engage the lock.
4. Release the brake lever.
5. To release the parking brake lock, squeeze and release the brake lever. It will return to its unlocked position.

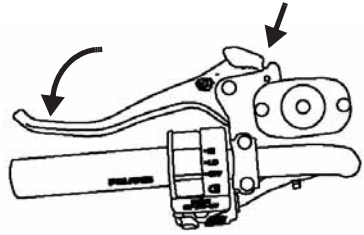

WARNING! Operating the ATV while the parking brake is engaged could result in an accident or fire. Always check to be sure the parking brake is disengaged before operating.

The parking brake may relax if left on for a long period of time. Always block the wheels to prevent rolling. Always block the wheels on the downhill side of the ATV if leaving it parked on a hill. Another option is to park the ATV in a sidehill position. Never depend on the parking brake alone if the ATV is parked on a hill. Always block the wheels to prevent rolling.

FEATURES AND CONTROLS

Auxiliary Foot Brake

⚠ WARNING

Never back down a hill. Applying the auxiliary brake when backing down a hill may cause rear tipover, which could result in serious injury or death.

Use caution when applying the auxiliary brake. Do not aggressively apply the auxiliary brake when going forward. The rear wheels may skid and slide sideways, causing loss of control and serious injury or death.

The auxiliary brake system is intended to be used as a backup for the main brake system. Should the main system fail, use the auxiliary foot brake.

The auxiliary foot brake is located on the inside of the right footrest. Operate this brake with your right foot.

If the rear wheels slide while using the auxiliary brake, *reduce* brake pedal pressure to brake the rear wheels without skidding.

Brake Fluid Level

Check the brake fluid level frequently for the auxiliary brake system. The reservoir is located under the front rack.

Maintain the fluid level between the maximum and minimum marks. Use DOT 4 brake fluid only.

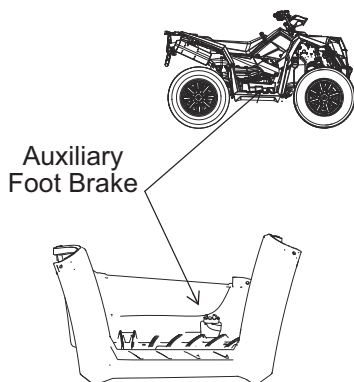

Brake Fluid Reservoir

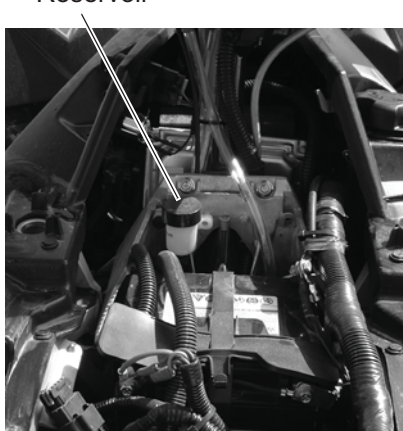

FEATURES AND CONTROLS

Fuel Tank

Always refuel with the engine stopped, and outdoors or in a well ventilated area. Refuel on a level surface.

Remove the fuel tank cap and add fuel. Use either leaded or unleaded gasoline with a minimum pump octane number of 87=(R+ M/2) octane. *Do not use fuel with ethanol content greater than 10%, such as E-85 fuel.*

The fuel tank is designed to allow for the normal expansion of fuel. Do not overfill. Do not fill the tank neck.

Fuel Tank Cap



Extreme Use 30 AH Battery

If your factory-installed 18 AH battery cannot maintain a charge because of operation in extreme cold or with multiple electrical accessories, please see your POLARIS dealer to purchase a 30 AH battery.

1. Fully charge the new battery before installing it. See page 110.
2. To install the 30 AH battery, remove the 18 AH battery. See page 108.
3. Remove the plastic spacer at the bottom of the battery compartment. Save the spacer for future use.
4. Install the new battery. See page 109.

Electronic Power Steering (EPS)

Electronic power steering (EPS) engages when the ignition key is turned to the ON position. EPS remains engaged whether the vehicle is moving or idle. See page 43 for EPS Warning Indicator information.

FEATURES AND CONTROLS

All Wheel Drive System

The All Wheel Drive system is controlled by the 4X4 switch.

4X4 Mode

When the switch is on 4X4, the ATV is in 4X4, and the 4X4 indicator icon in the instrument cluster display will be visible.

When in 4X4, the demand drive unit will automatically engage any time the rear wheels lose traction. When the rear wheels regain traction, the demand drive unit will automatically disengage.

There is no limit to the length of time the vehicle may remain in 4X4. The vehicle automatically engages 4X4 when operating in reverse if the switch is set to the 4X4 position.

2X4 Mode

When the switch is on 2X4, the ATV is in two-wheel drive at all times.

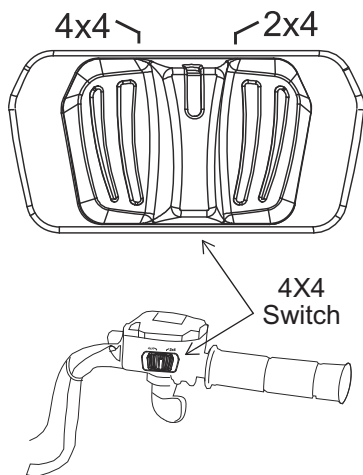

FEATURES AND CONTROLS

All Wheel Drive System

Engaging 4X4

The 4X4 switch may be turned on or off while the vehicle is moving. Initially, the vehicle's electronic system will not enable 4X4 until the engine RPM is below 3100. Once enabled, 4X4 remains enabled until the 4X4 switch is turned off. If the switch is turned off while the demand drive unit is moving, it will not disengage until the rear wheels regain traction.

Engage the 4X4 switch before getting into conditions where front wheel drive may be needed. If the rear wheels are spinning, release the throttle before switching to 4X4.

NOTICE: Switching to 4X4 while the rear wheels are spinning may cause severe drive shaft and gearcase damage. Always switch to 4X4 while the rear wheels have traction or are at rest.

FEATURES AND CONTROLS

Instrument Cluster

NOTICE: High water pressure may damage ATV components. Wash the ATV by hand or with a garden hose using mild soap.

Certain products, including insect repellents and chemicals, will damage the speedometer lens and other plastic surfaces. Do not use alcohol to clean the instrument cluster. Do not allow insect sprays to contact the lens. Immediately clean off any gasoline that splashes on the instrument cluster.

Digital/Analog Gauge

Speedometer

The speedometer displays vehicle speed in either miles per hour (MPH) or kilometers per hour (km/h).

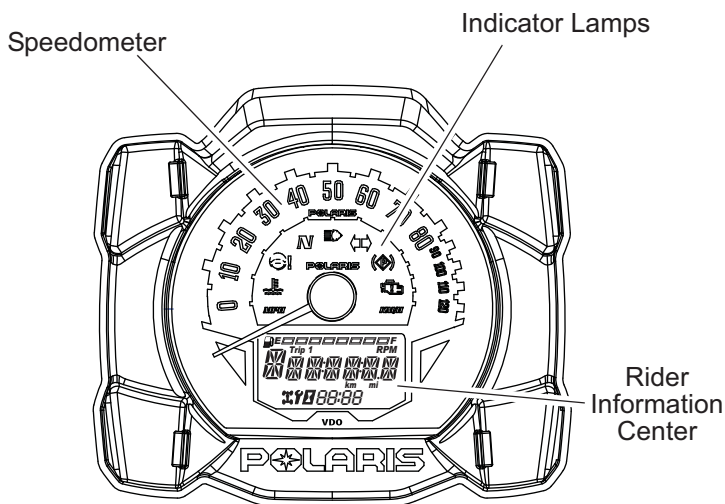







FEATURES AND CONTROLS

Instrument Cluster

Digital/Analog Gauge

Indicator Lamps

Lamp	Indicates	Condition
	Vehicle Speed	When standard mode is selected, speed displays in miles per hour.
		When metric mode is selected, speed displays in kilometers per hour.
	Over Temperature	This lamp flashes to indicate an overheated engine. If the indicator stops flashing but remains illuminated, the overheating condition remains, and the system will automatically reduce engine power.
	Neutral	This lamp illuminates when the transmission is in neutral and the ignition key is in the ON position.
	High Beam	This lamp illuminates when the headlamp switch is set to high beam.
	Check Engine	This indicator appears if an EFI-related fault occurs. Do not operate the ATV if this warning appears. Serious engine damage could result. See your dealer.

FEATURES AND CONTROLS

Instrument Cluster

Digital/Analog Gauge

Rider Information Center

The rider information center is located in the instrument cluster. All segments will light up for one second at start-up. If the instrument cluster fails to illuminate, a battery over-voltage may have occurred and the instrument cluster may have shut off to protect the electronic speedometer. If this occurs, take the ATV to your POLARIS dealer for proper diagnosis.

The information center is set to display standard units of measurement and a 12-hour clock at the factory. To change to metric and/or a 24-hour clock, see page 39.

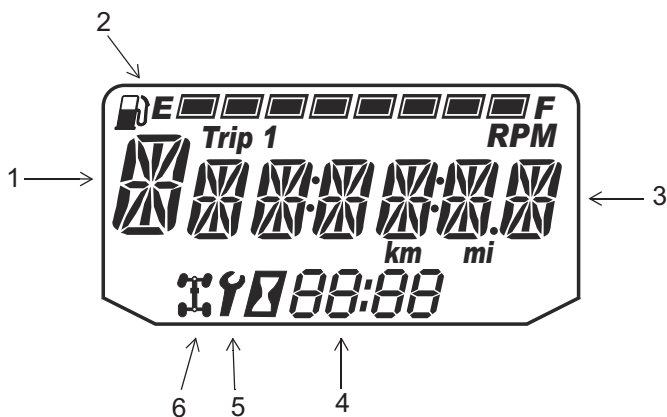

FEATURES AND CONTROLS

Instrument Cluster

Digital/Analog Gauge

Rider Information Center

1. **Gear Display** - This area displays gear shifter position.
H = High Gear
L = Low Gear
N = Neutral
R = Reverse Gear
P = Park
-- = Gear Signal Error (or shifter between gears)
2. **Fuel Gauge Display** - The segments of the fuel gauge show the level of fuel in the fuel tank. When the last segment clears, a low fuel warning is activated. All segments including the fuel icon will flash. Refuel immediately.
Tip: If the fuel icon fails to display, an open or short circuit has occurred in the fuel sensor circuit. See your dealer.
3. **Information Display** - This area displays odometer, trip meter, engine hour meter, engine speed and programmable service hour interval.
4. **Clock Display** - The clock displays time in a 12-hour or 24-hour format. If the engine is turned off, press the MODE button. The time will display for 5-10 seconds. See page 39 for resetting instructions.
5. **Service Reminder Display** - A flashing wrench symbol alerts the operator that the preset service interval has been reached. The vehicle should be brought to your dealer for scheduled maintenance. See page 39 for resetting instructions.
6. **4X4 Display** - This icon displays when the 4X4 system is engaged (switch is on 4X4).

FEATURES AND CONTROLS

Instrument Cluster

Digital/Analog Gauge

Rider Information Center

The reverse override button acts as the MODE button when pressed and released quickly. The transmission cannot be in reverse when using the override button as a MODE button. This feature does not contain a vehicle speed lockout function and can be used at any operating speed.

Display Units (Standard/Metric)

The display can be changed to display either standard or metric units of measurement.

Tip: To exit the set-up mode at any time, wait 10 seconds. The display automatically exits and returns to the odometer display.

	Standard Display	Metric Display
Distance	Miles	Kilometers
Time	12-Hour Clock	24-Hour Clock

1. Turn the key to the OFF position.
2. Place the transmission in neutral.
3. Press and *hold* the MODE button while turning the key to the ON position.
4. When the display flashes the distance setting, tap the MODE button to advance to the desired setting.
5. Press and *hold* the MODE button to save the setting and advance to the next display option.
6. Repeat the procedure to change remaining display settings.

FEATURES AND CONTROLS

Instrument Cluster

Digital/Analog Gauge

Rider Information Center

Clock Mode

Tip: The clock must be reset any time the battery has been disconnected or discharged.

1. Turn the key to the ON position. Use the MODE button to toggle to the odometer display.
2. Press and *hold* the MODE button until the hour segment flashes. Release the button.
3. With the segment flashing, tap the MODE button to advance to the desired setting.
4. Press and *hold* the MODE button until the next segment flashes. Release the button.
5. Repeat steps 3-4 twice to set the 10-minute and 1-minute segments. After completing the 1-minute segment, step 4 will save the new settings and exit the clock mode.
6. Turn the key to the OFF position.

Odometer Mode

The odometer records and displays the distance traveled by the ATV.

Trip Meter Mode

The trip meter records the distance traveled by the ATV if reset before each trip. To reset, select the trip meter mode. Press and hold the MODE button until the meter resets to zero. In the Rider Information Center, the trip meter display contains a decimal point, but the odometer displays without a decimal point.

Hour Meter Mode

This mode logs the total hours the engine has been in operation.

FEATURES AND CONTROLS

Instrument Cluster

Digital/Analog Gauge

Rider Information Center

Programmable Service Interval

When the hours of engine operation equal the programmed service interval setting, the wrench icon will flash for 5 seconds each time the engine is started. When this feature is enabled, it provides a convenient reminder to perform routine maintenance. The service interval is programmed at 50 hours at the factory. Use the following procedure to change the service interval.

1. Press the MODE button until remaining service hours display.
2. Press and hold the MODE button.
3. When the service hours flash, press and release the MODE button to advance the hours to the desired setting (including OFF). Press and hold the MODE button to set the new service hour interval.

Diagnostic Display Mode

The EFI diagnostic display mode is for informational purposes only. Please see your POLARIS dealer for all major repairs.

The diagnostic mode is accessible only when the check engine warning indicator activates after the key has been turned on. Leave the key on if you want to view the active code (failure code).

The diagnostic mode becomes inaccessible if the key is turned off and on and the warning indicator is no longer active. This allows the determination of persistent as well as intermittent faults.

Inactive codes are stored in the history of the unit.

FEATURES AND CONTROLS

Instrument Cluster

Multi-Function Display (MFD) Gauge (EPS Models)

The rider information center is located in the instrument cluster. All segments will light up for one second at start-up. If the instrument cluster fails to illuminate, a battery over-voltage may have occurred and the cluster may have shut down to protect the electronic speedometer. If this occurs, take the ATV to your Polaris dealer for proper diagnosis.



The information center is set to display standard units of measurement and a 12-hour clock at the factory. To change to metric and/or a 24-hour clock, see page 45.

- 1. Gear Display -**
This area displays gear shifter position.
H = High Gear
L = Low Gear
N = Neutral
R = Reverse Gear
P = Park
-- = Gear Signal Error (or shifter between gears)



- 2. Information Display -** This area displays odometer, tripmeters, engine hour meter and programmable service hour interval.
- 3. Speed Display -** This area displays vehicle ground speed or engine speed. See page 44.

FEATURES AND CONTROLS

Instrument Cluster

Multi-Function Display (MFD) Gauge (EPS Models)

- Fuel Gauge** - The segments of the fuel gauge show the level of fuel in the fuel tank. When the last segment clears, a low fuel warning is activated. All segments including the fuel icon will flash. Refuel immediately.
- Tip:** If the fuel icon fails to display, an open or short circuit has occurred in the fuel sensor circuit. See your dealer.
- High Beam Indicator** - This indicator illuminates when the lights are set to high beam.
- Engine Overheat Warning** - This icon flashes to indicate an overheated engine. If the icon stops flashing but remains illuminated, the overheating condition remains, and the system will automatically reduce engine power.
- Clock Display** - The clock displays time in a 12-hour or 24-hour format. If the engine is turned off, press the MODE button. The time will display for 5-10 seconds. See page 46 for resetting instructions.
- Service Reminder Display** - A flashing wrench symbol alerts the operator that the preset service interval has been reached. The vehicle should be brought to your dealer for scheduled maintenance. See page 46 for resetting instructions.
- Under / Over Voltage** - This warning usually indicates that the ATV is operating at an RPM too low to keep the battery charged. It may also occur when the engine is at idle and high electrical load (lights, cooling fan, accessories) is applied. Drive at a higher RPM or recharge the battery to clear the warning.
- Check Engine Warning** - This icon displays if an EFI-related fault occurs. Do not operate the ATV if this warning appears. Serious engine damage could result. See your dealer.
- 4X4 Display** - This icon displays when the 4X4 system is engaged (switch is on either ADC 4X4 or 4X4).
- Neutral Indicator** - This indicator illuminates, in addition to displaying in the gear indicator display, when the transmission is in neutral.
- EPS Warning Indicator** - If this indicator light remains on after starting the engine, the EPS system is inoperative. See your authorized Polaris dealer for service.

FEATURES AND CONTROLS

Instrument Cluster

Multi-Function Display (MFD) Gauge (EPS Models)

Use the MODE button to toggle through the speed display options.

Use the SELECT button (SEL) to toggle through the information area options.

MODE and SELECT button operation is locked out at speeds above approximately 15 MPH (25 km/h).

Tip: The reverse override button also acts as a MODE button when held down for approximately one half second. The reverse override button also acts as the SELECT button when pressed and released quickly. The transmission cannot be in reverse when using the override button as a MODE or SELECT button. This feature does not contain a vehicle speed lockout function and can be used at any operating speed.



MODE
Button

SELECT
Button

Speed Display

Use the MODE button to toggle through the speed display options.

Ground speed is displayed in either miles per hour (MPH) or kilometers per hour (km/h).

Engine speed is displayed in revolutions per minute (RPM).

FEATURES AND CONTROLS

Instrument Cluster

Multi-Function Display (MFD) Gauge (EPS Models)

Display Units (Standard/Metric)

The display can be viewed in either standard or metric units of measurement. To change units:

1. Press and hold the MODE button until vehicle speed is displayed.
2. Toggle through the information area using the SELECT button until the odometer is displayed.
3. Press and hold the MODE button until the displayed units change. Release the button.
4. New settings remain until changed using the same procedure.

12-Hour/24-Hour Clock Display

1. Press and hold the MODE button until RPM is displayed.
2. Toggle through the information area using the SELECT button until the odometer is displayed.
3. Press and hold the MODE button until the clock displays the new clock format (either 24-hour or 12-hour). Release the button.
4. New settings remain until changed using the same procedure.

Odometer Mode

The odometer records and displays the distance traveled by the ATV.

Trip Meter Mode

The trip meters record the distance traveled by the ATV on each trip if reset before each trip. To reset a trip meter, select the trip meter 1 or trip meter 2 mode. Press and hold the MODE button on the instrument cluster until the total changes to 0. In the Rider Information Center, the trip meter display contains a decimal point, but the odometer displays without a decimal point.

Hour Meter Mode

This mode logs the total hours the engine has been in operation.

FEATURES AND CONTROLS

Instrument Cluster

Multi-Function Display (MFD) Gauge (EPS Models)

Programmable Service Interval

When the hours of engine operation equal the programmed service interval setting, the wrench icon will flash for 5 seconds each time the engine is started. When this feature is enabled, it provides a convenient reminder to perform routine maintenance. The service interval is programmed at 50 hours at the factory. Use the following procedure to change the service interval.

1. Press the SELECT button until remaining service hours display.
2. Press and hold the MODE button.
3. When the service hours flash, press and release the SELECT button to advance the hours to the desired setting (including OFF). When the digits stop flashing, the interval has been set.

Clock Mode

Use one of the following two methods to reset the clock.

Method 1

1. Select the Hour Meter Mode.
2. Press and hold the mode button on the instrument cluster until the hour display flashes. Release the button.
3. Press and release the SELECT button to advance the hours.
4. After the hours are set, press and release the MODE button to move to the minutes. Use the same procedure to reset the minutes.
5. When the digits stop flashing the clock has been set.

Method 2

1. With the key turned off, press and hold the MODE button.
2. While still holding the MODE button, turn the key to the ON position.
3. Continue to hold the MODE button until the hour display flashes. Release the button.
4. Set the time as outlined in steps 3-5 of Method 1.

FEATURES AND CONTROLS

Instrument Cluster

Multi-Function Display (MFD) Gauge (EPS Models)

Diagnostic Display Mode

The EFI diagnostic display mode is for informational purposes only. Please see your Polaris dealer for all major repairs.

The diagnostic mode is accessible only when the check engine warning indicator activates after the key has been turned on. Leave the key on if you want to view the active code (failure code).

The diagnostic mode becomes inaccessible if the key is turned off and on and the warning indicator is no longer active. This allows the determination of persistent as well as intermittent faults.

Inactive codes are stored in the history of the unit. Please see your Polaris dealer to retrieve inactive codes.

Use the following procedure to view active codes that occur when the key is on.

1. Place the transmission in PARK.
 2. Press and release the SELECT button until the flashing check engine warning indicator appears in the display.
 3. A set of two numbers will also appear in the display.
 - The 2-6 digit suspect parameter number (SPN) in the information area indicates which component is generating the fault code.
 - The 1-2 digit failure mode indicator (FMI) number in the clock area indicates the fault mode, such as open or short circuit.
 4. See pages 48-50 for code definitions and failure descriptions.
- Tip:** More than one fault may be active. Press and hold the MODE button to toggle through all currently active diagnostic codes.

FEATURES AND CONTROLS

Instrument Cluster

Diagnostic Display Code Definitions

Open Load: There is a break in the wires that lead to the item listed in the chart (injector, fuel pump, etc.), or the item has failed.

Short-to-Ground: The wire is shorted to ground between the electronic control unit and the item listed in the chart.

Shorted Load: The wires leading to the item listed in the chart are shorted together, or the item has shorted internally.

Short-to-Battery: The wire leading from the item listed in the chart to the electronic control unit is shorted to a wire at battery voltage.

SCRAMBLER 850 XP / 850 XP EPS Diagnostic Codes

Component	Condition	SPN	FMI
Throttle Position Sensor	Voltage Too High	51	3
	Voltage Too Low	51	4
Engine Temperature Sensor	Voltage Too High	110	3
	Voltage Too Low	110	4
	Temperature Too High	110	16
	Engine Overheat Shutdown	110	0
Intake Air Temperature Sensor	Voltage Too High	105	3
	Voltage Too Low	105	4
Manifold Absolute Pressure Sensor	Voltage Too High	102	3
	Voltage Too Low	102	4
	Signal Out of Range	102	2
Crankshaft Position Sensor	Circuit Fault	636	8
	Plausibility Fault	636	2
Vehicle Speed Signal	Speed Too High	84	8
	Plausibility Fault	84	2
Gear Sensor Signal	Voltage Too Low	523	4
	Voltage too high	523	3
	Signal fault	523	2
Injector 1 (MAG) (SDI Part Load)	Driver Circuit Open/Grounded	651	5
	Driver Circuit Short to B+	651	3
	Driver Circuit Grounded	651	4

FEATURES AND CONTROLS

Instrument Cluster

Diagnostic Display Code Definitions

SCRAMBLER 850 XP / 850 XP EPS Diagnostic Codes			
Component	Condition	SPN	FMI
Injector 2 (PTO) (SDI Part Load)	Driver Circuit Open/Grounded	652	5
	Driver Circuit Short to B+	652	3
	Driver Circuit Grounded	652	4
Ignition Coil Primary Driver 1 (MAG)	Driver Circuit Short to B+	1268	3
Ignition Coil Primary Driver 2 (PTO)	Driver Circuit Short to B+	1269	3
Fuel Pump Driver Circuit	Driver Circuit Open/Grounded	1347	5
	Driver Circuit Short to B+	1347	3
	Driver Circuit Grounded	1347	4
Fan Relay Driver Circuit	Driver Circuit Open/Grounded	1071	5
	Driver Circuit Short to B+	1071	3
	Driver Circuit Grounded	1071	4
Idle Air Control	Driver Circuit Open/Grounded	634	5
	Driver Circuit Short to B+	634	3
	Driver Circuit Grounded	634	4
	Position Out of Range	634	7
Starter Enable Circuit	Driver Circuit Open/Grounded	1321	5
	Driver Circuit Short to B+	1321	3
	Driver Circuit Grounded	1321	4
Chassis Relay	Driver Circuit Open/Grounded	520208	5
	Driver Circuit Short to B+	520208	3
	Driver Circuit Grounded	520208	4
All Wheel Drive Control	Driver Circuit Open/Grounded	520207	5
	Driver Circuit Short to B+	520207	3
	Driver Circuit Grounded	520207	4
System Power	Voltage Too High	168	3
	Voltage Too low	168	4
Throttle Safety Signal	Voltage Too High	520194	3
	Voltage Too Low	520194	4
	Signal Out of Range	520194	2
	Throttle Stuck	520194	7
Idle Speed	Speed Too High	520211	3
	Speed Too Low	520211	4

FEATURES AND CONTROLS

Instrument Cluster

Diagnostic Display Code Definitions

SCRAMBLER 850 XP EPS Diagnostic Codes			
EPS Models Only			
Steering Over Current Shutdown	Current Above Normal/Grounded	520221	6
Steering Excessive Current Error	Current Above Normal/Grounded	520222	6
Steering Torque Sensor T1 Partial Failure	T1 Shorted to Ground	520223	4
	T1 Shorted to Bus	520223	3
Steering Torque Sensor T2 Partial Failure	T2 Shorted to Ground	520224	4
	T2 Shorted to Bus	520224	3
Steering Torque Sensor Full Failure	T1 and T2 Shorted to Ground	520225	4
	T1 and T2 Shorted to Bus	520225	3
	T1 Short to Ground & T2 Short to Bus	520225	16
	T2 Short to Ground & T1 Short to Bus	520225	17
	T1 and T2 are Shorted	520225	2
Steering Position Sensor P1 Partial Failure	P1 Shorted to Ground	520226	4
	P1 Shorted to Bus	520226	3
Steering Position Sensor P2 Partial Failure	P2 Shorted to Ground	520227	4
	P2 Shorted to Bus	520227	3
Steering Position Sensor Full Failure	P1 and P2 Shorted to Ground	520228	4
	P1 and P2 Shorted to bus	520228	3
EPAS Inverter Temperature	Greater than 110 Degrees C	520229	16
	Greater than 120 Degrees C	520229	0
EPAS CAN Comm. Receive Err	No RX Message for 2 Seconds	520230	9
EPAS CAN Comm. Transmit Err	No TX Message for 2 Seconds	520231	9
IC CAN Comm. w/EPAS	EPAS Offline	520230	31

FEATURES AND CONTROLS

Front Rack/Compartment

Release the front rack latches and remove the rack to gain access to the front compartment. To reinstall the rack, hold the rack as shown in the illustration. Position the front edge in the tabs, then push the rack downward and secure the latches.

Access the following components in the front compartment:

- Radiator cap
- Brake fluid reservoir
- Battery
- Coolant recovery bottle cap
- Electrical/fuse/relay components

Latches

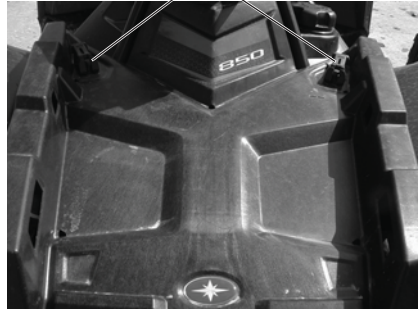

Coolant Bottle Cap



Radiator Cap

Brake Fluid Reservoir

Battery

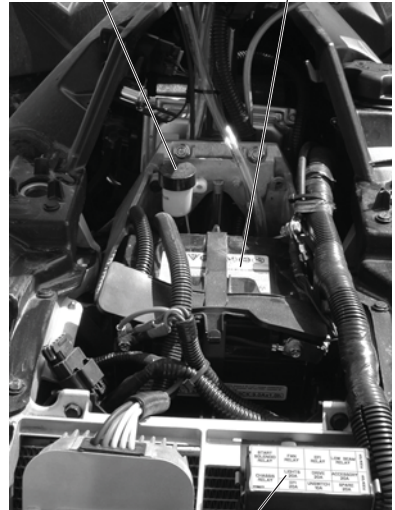

Electrical/Fuse/Relay

OPERATION

WARNING

Failure to operate the ATV properly can result in a collision, loss of control, accident or overturn, which may result in serious injury or death. Read and understand all safety warnings outlined in the safety section of this owner's manual.

Break-In Period

The break-in period for your new POLARIS ATV is the first 20 hours of operation. No single action on your part is as important as following the procedures for a proper break-in. Careful treatment of a new engine and drive components will result in more efficient performance and longer life for these components.

NOTICE: Excessive heat build-up during the first three hours of operation will damage close-fitted engine parts and drive components. Do not operate at full throttle or high speeds during the first three hours of use.

Break-In Period

Engine and Drivetrain Break-in

1. Fill the fuel tank with gasoline. See page 31. Always exercise extreme caution whenever handling gasoline.
2. Check the engine oil level on the dipstick. See page 77. Add oil if necessary to maintain the level between the safe and add marks.
3. Drive slowly at first. Select an open area that allows room to familiarize yourself with vehicle operation and handling.
4. Vary the throttle positions. Do not operate at sustained idle.
5. Perform regular checks on fluid levels, controls and areas outlined on the daily pre-ride inspection checklist. See page 54.
6. Pull only light loads.
7. Change both the oil and the filter at 25 hours.
8. Check fluid levels of transmission and all gearcases after the first 25 hours of operation and every 100 hours thereafter.

PVT Break-in (Clutches/Belt)

A proper break-in of the clutches and drive belt will ensure a longer life and better performance. Break in the clutches and belt by operating at slower speeds during the break-in period as recommended. Pull only light loads. Avoid aggressive acceleration and high speed operation during the break-in period.

If a belt fails, always clean away all debris when replacing the belt.

OPERATION

Pre-Ride Checklist

Failure to inspect and verify that the ATV is in safe operating condition before operating increases the risk of an accident. Always inspect the ATV before each use to make sure it's in safe operating condition.

Item	Remarks	Page
Brake system/lever travel	Ensure proper operation	27 87
Brake fluid	Ensure proper level	28
Auxiliary brake	Ensure proper operation	30
Front suspension	Inspect, lubricate if necessary	76
Rear suspension	Inspect, lubricate if necessary	76
Steering	Ensure free operation	-
Tires	Inspect condition and pressure	90
Wheels/fasteners	Inspect, ensure fastener tightness	90 91
Frame nuts, bolts, fasteners	Inspect, ensure tightness	-
Fuel and oil	Ensure proper levels	31 77
Coolant level	Ensure proper level	85 86
Coolant hoses	Inspect for leaks	-
Throttle	Ensure proper operation	26 106
Indicator lights/switches	Ensure operation	24
Engine stop switch	Ensure proper operation	25
Air filter, pre-filter	Inspect, clean	92
Headlamp	Check operation	24 94
Brake light/tail lamp	Check operation	95
Riding gear	Wear approved helmet, goggles, and protective clothing	8

Safe Operation Practices

1. Complete the recommended safety training before operating this vehicle. See page 7.
2. Do not allow anyone under 16 years of age to operate this vehicle. Do not allow anyone with cognitive or physical disabilities to operate this vehicle.
3. Never carry a passenger on this ATV.
4. Engine exhaust fumes are poisonous. Never start the engine or let it run in an enclosed area.
5. Before operating, learn how to use the auxiliary brake for emergency situations (if service brakes become inoperable).
6. Operate this vehicle off-road only. Never operate the vehicle on pavement or on any public street, road or highway, including dirt and gravel roads.
7. Use caution and drive at reduced speeds in conditions of reduced visibility such as fog, rain and darkness. Clean headlights frequently and replace burned out headlamps promptly.
8. Drive in a manner appropriate for your skills and operating conditions. Never operate at excessive speeds. Never attempt wheelies, jumps, or other stunts. Never remove your hands from the handlebars while operating, and always keep both feet on the footrests.
9. Never consume alcohol or drugs before or while operating an ATV.
10. Always use the size and type of tires specified for your vehicle. Always maintain proper tire pressure.
11. Never operate a damaged ATV. After any overturn or accident, have a qualified service dealer inspect the entire machine for possible damage.
12. Never operate the ATV on a frozen body of water unless you have independently verified that the ice is sufficiently thick to support the weight and moving force of the ATV, you and your cargo, together with any other vehicles in your party.
13. Do not touch hot exhaust system components. Always keep combustible materials away from the exhaust system.
14. Always remove the ignition key when the vehicle is not in use to prevent unauthorized use.

OPERATION

Know Your Riding Area/Tread Lightly

Familiarize yourself with all laws and regulations concerning the operation of this off-road vehicle in your area. Respect the environment in which you ride. Find out where the designated riding areas are by contacting your POLARIS dealer, a local riding club or local officials.

Help keep our trails open for recreational vehicle use. As an off-road enthusiast, you represent the sport and can set a good example (or a poor example) for others to follow. Tread lightly. Operate with respect for the terrain, avoid littering, and always stay on the designated trails.

Trail Etiquette

Always practice good etiquette when riding. Allow a safe distance between your vehicle and other vehicles operating in the same area. Communicate to oncoming operators by signaling the number of vehicles in your group. When stopping, move your vehicle to the edge of the trail as far as possible to allow others to pass safely.

Starting the Engine

1. Position the vehicle on a level surface outdoors or in a well-ventilated area.
2. Place the transmission in PARK.
3. Lock the parking brake.

Tip: The starter interlock will prevent the engine from starting if the transmission is in gear and the brake is not engaged.

4. Sit on the vehicle and move the engine stop switch to RUN.
5. Do not press the throttle while starting the engine.
6. Turn the ignition key past the ON position to engage the starter. Activate the starter for a maximum of five seconds, releasing the key when the engine starts.
7. If the engine does not start, return the key to the OFF position and wait five seconds before attempting to start again. Activate the starter for another five seconds if necessary. Repeat this procedure until the engine starts.

NOTICE: Operating the vehicle immediately after starting could cause engine damage. Allow the engine to warm up for several minutes before operating the vehicle.

Cold Weather Operation

If the ATV is used year-round, check the oil level frequently. A rising oil level could indicate the accumulation of contaminants such as water or excess fuel in the bottom of the crankcase. Water in the bottom of the crankcase can lead to engine damage and must be drained. Water accumulation increases as outside temperature decreases.

OPERATION

Driving Procedures

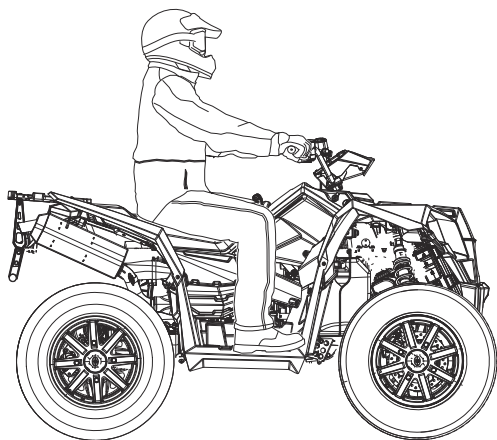

1. Wear a helmet and eye protection.
2. Sit upright with both feet on the footrests and both hands on the handlebars.
3. Start the engine and allow it to warm up.
4. Shift the transmission into gear.
5. Check your surroundings and determine your path of travel.
6. Release the parking brake.
7. Slowly depress the throttle with your right thumb and begin driving.
8. Drive slowly. Practice maneuvering and using the throttle and brakes on level surfaces.

Turning the Vehicle

Your ATV is equipped with a solid rear axle, which drives both rear wheels equally at all times. This means that the wheel on the outside of the turn must travel a greater distance than the inside wheel when turning and the inside tire must slip traction slightly.

To turn, steer in the direction of the turn, leaning your upper body to the inside of the turn while supporting your weight on the outer footrest. This technique alters the balance of traction between the rear wheels, allowing the turn to be made smoothly. The same leaning technique should be used for turning in reverse.

Practice making turns at slow speeds before attempting to turn at faster speeds.

WARNING! Turning improperly can result in vehicle overturn. Never turn abruptly or at sharp angles. Never turn at high speeds.

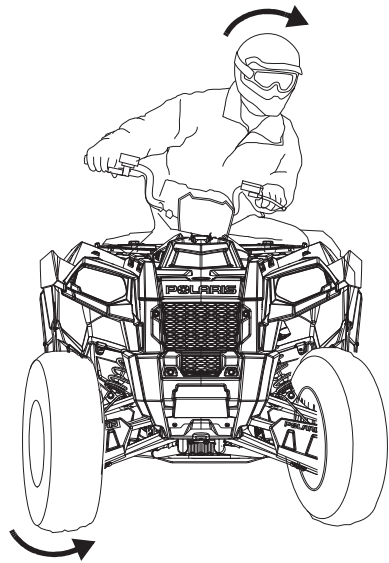

OPERATION

Driving on Slippery Surfaces

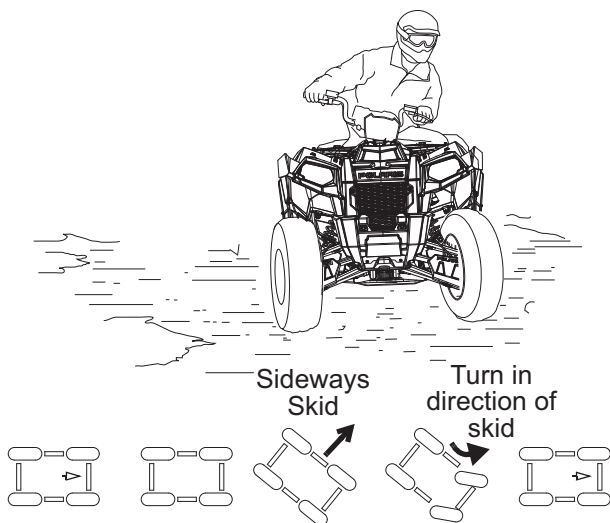

Whenever riding on slippery surfaces such as wet trails or loose gravel, or during freezing weather, follow these precautions:

1. Do not operate on excessively rough, slippery or loose terrain.
2. Slow down when entering slippery areas.
3. Engage 4X4 before wheels begin to lose traction.

NOTICE: Severe damage to drive train may occur if the 4X4 is engaged while the wheels are spinning. Allow the rear wheels to stop spinning before engaging 4X4, or engage 4X4 before wheels begin to lose traction.

4. Maintain a high level of alertness, reading the trail and avoiding quick, sharp turns, which can cause skids.
5. Never apply the brakes during a skid. Correct a skid by turning the handlebars in the direction of the skid and shifting your body weight forward.

Driving Uphill

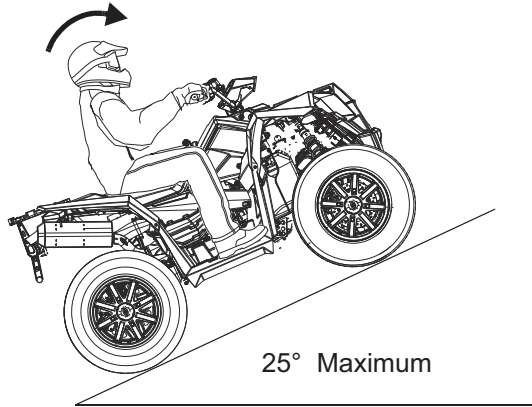

Braking and handling are greatly affected when operating in hilly terrain. Improper procedure could cause loss of control or overturn. Whenever traveling uphill, follow these precautions:

1. Drive straight uphill.
2. Avoid steep hills (25° maximum).
3. Always check the terrain carefully before ascending any hill.
4. Never climb hills with excessively slippery or loose surfaces.
5. Keep both feet on the footrests.
6. Shift body weight uphill.
7. Proceed at a steady rate of speed and throttle opening. Opening the throttle suddenly could cause the ATV to flip over backwards.
8. Never go over the top of any hill at high speed. An obstacle, a sharp drop, or another vehicle or person could be on the other side of the hill.
9. Remain alert and be prepared to take emergency action. This may include quick dismounting of the vehicle.

OPERATION

Driving on a Sidehill (Sidehilling)

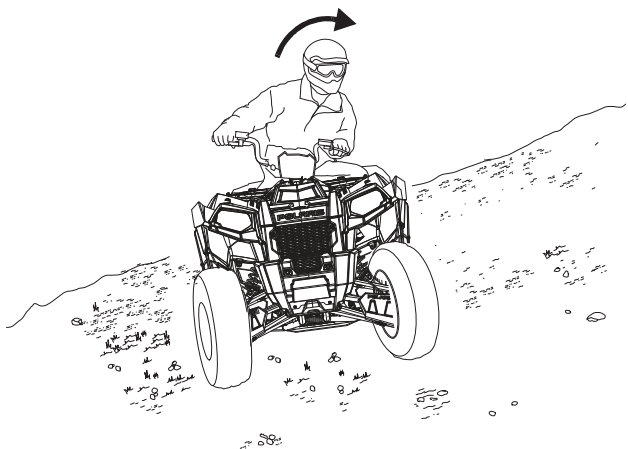

Driving on a sidehill is not recommended. Improper procedure could cause loss of control or overturn. Avoid crossing the side of any hill unless absolutely necessary.

If crossing a sidehill is *unavoidable*, follow these precautions:

1. Slow down!
2. Shift body weight uphill.
3. Keep your feet on the footrests.
4. If the vehicle begins to slide or tip, quickly turn the front wheel downhill, if possible, or dismount on the uphill side *immediately!*

Driving Downhill

When driving downhill, follow these precautions:

1. Avoid steep hills (25° maximum).
2. Shift body weight uphill.
3. Drive straight downhill.
4. Slow down. Excessive speed when traveling downhill can cause loss of control.
5. Squeeze the brake lever gradually. Applying the brakes too firmly may cause the rear wheels to lock, which could result in loss of control.

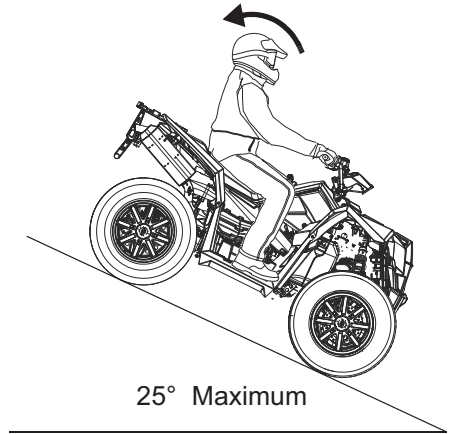

Parking on an Incline

Avoid parking on an incline if possible. If it's unavoidable, follow these precautions:

1. Stop the engine.
2. Place the transmission in PARK.
3. Lock the parking brake.
4. Always block the rear wheels on the downhill side.

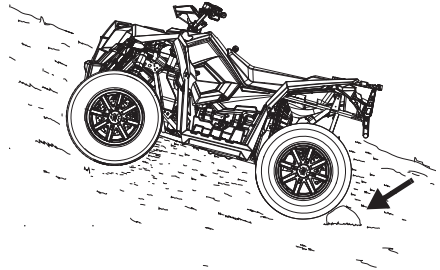

OPERATION

Turning Around on a Hill (K-Turn)

If the vehicle stalls while climbing a hill, never back it down the hill!
Use the K-turn to turn around.

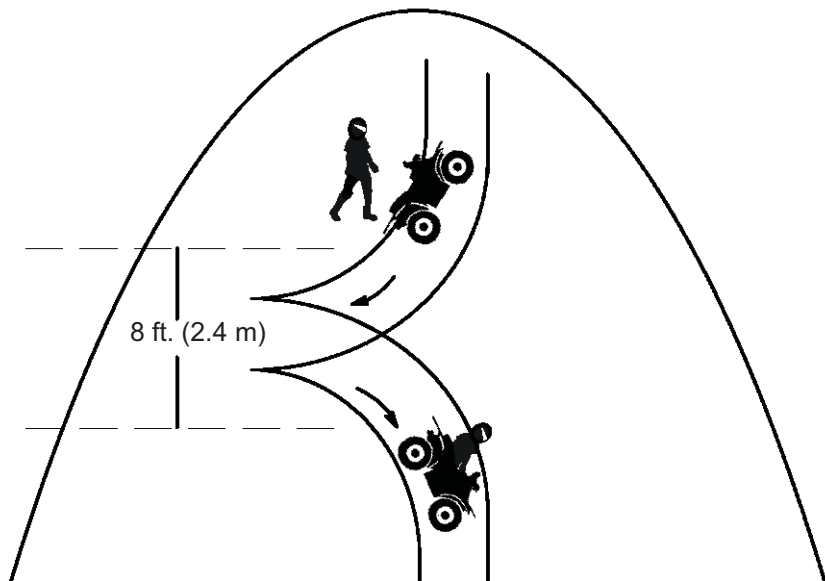

1. Stop and lock the parking brake while keeping body weight uphill.
2. Leave the transmission in forward and shut off the engine.
3. Dismount on the uphill side of the vehicle, or on the left if the vehicle is pointing straight uphill.
4. Staying uphill of the vehicle, turn the handlebars full left.
5. While holding the service brake, release the parking brake lock and slowly allow the vehicle to roll around to your right until it's pointing across the hill or slightly downward.
6. Lock the parking brake and remount the vehicle from the uphill side, keeping body weight uphill.
7. Restart the engine with the transmission still in forward.
8. Release the parking brake and proceed *slowly*, controlling speed with the service brake, until the vehicle is on more level ground.

Driving Through Water

Your ATV can operate through water with a maximum recommended depth equal to the bottom of the footrests. Follow these precautions when operating through water:

1. Determine water depths and current before entering water.
2. Choose a crossing where both banks have gradual inclines.
3. Avoid operating through deep or fast-flowing water.

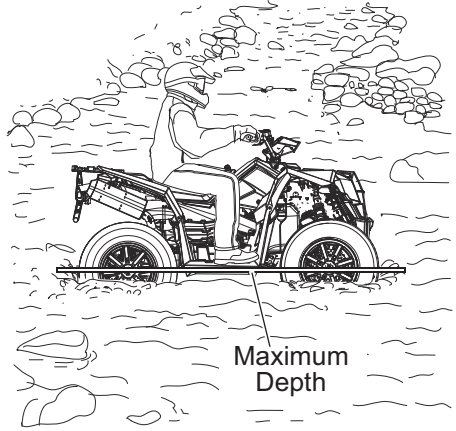

NOTICE: Major engine damage can result if the vehicle is not thoroughly inspected after operation in water. Perform the services outlined in the maintenance chart. See page 73. The following areas need special attention: engine oil, transmission oil, demand drive fluid, rear gearcase oil and all grease fittings.

If the vehicle tips or overturns in water, or if the engine stops during or after operating in water, restarting can result in serious engine damage. Transport the vehicle to your dealer for service before restarting the engine. If this is not possible, follow the vehicle immersion inspection and drying procedures outlined on page 98, then see your dealer for service at the first opportunity.

4. After leaving water, test the brakes. Apply them lightly several times while driving slowly. The friction will help dry out the pads.

If it's unavoidable to enter water deeper than the footrest level:

- Proceed slowly. Avoid rocks and obstacles.
- Balance your weight carefully. Avoid sudden movements.
- Maintain a steady rate of speed. Do not make sudden turns or stops. Do not make sudden throttle changes.

OPERATION

Driving Over Obstacles

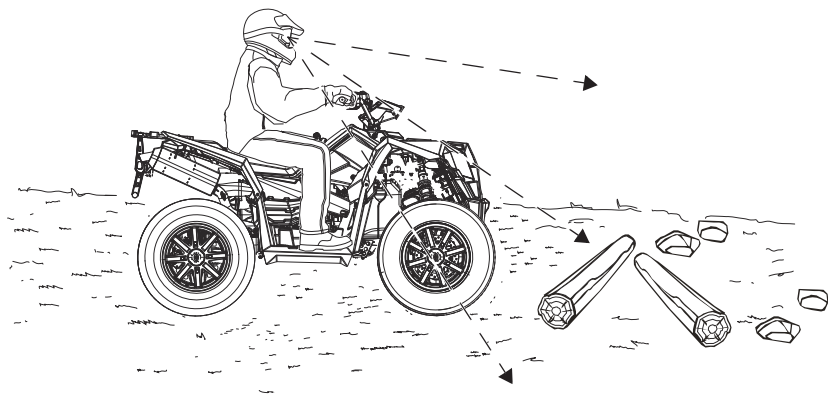

Follow these precautions when operating over obstacles:

1. Always check for obstacles before operating in a new area.
2. Look ahead and learn to read the terrain. Be constantly alert for hazards such as logs, rocks and low hanging branches.
3. Travel slowly and use extra caution when operating on unfamiliar terrain. Not all obstacles are immediately visible.
4. Never attempt to operate over large obstacles, such as rocks or fallen trees.

Driving in Reverse

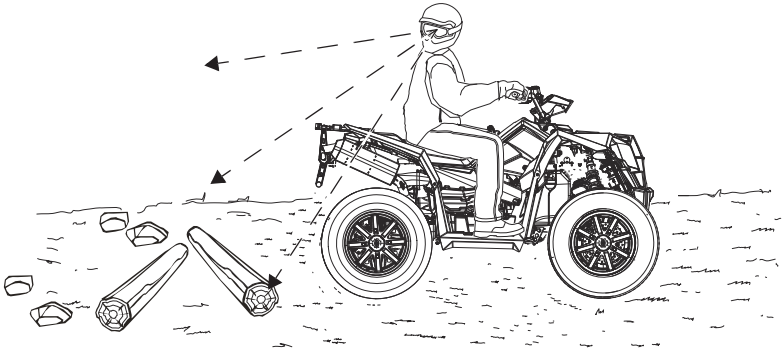

Follow these precautions when operating in reverse:

1. Always check for obstacles or people behind the vehicle.
2. Always avoid backing downhill.
3. Back slowly.
4. Apply the brakes *lightly* for stopping.
5. Avoid turning at sharp angles.
6. Never open the throttle suddenly.
7. Do not use the override button unless additional wheel speed is required for vehicle movement. Use the override with caution as rearward vehicle speed is greatly increased. Do not operate at wide open throttle. Operate the throttle just enough to maintain a desired speed.

NOTICE: Excessive throttle operation while in the speed limit mode may cause fuel to build in the exhaust, resulting in engine popping and/or engine damage.

OPERATION

Hauling Cargo

⚠ WARNING

Overloading the vehicle or carrying or towing cargo improperly can alter vehicle handling and may cause loss of control or brake instability, which can result in serious injury or death. Always follow these precautions when hauling cargo:

REDUCE SPEED AND ALLOW GREATER DISTANCES FOR BRAKING WHEN HAULING CARGO.

NEVER EXCEED THE MAXIMUM WEIGHT CAPACITY of the vehicle. When determining the weight you are adding to the vehicle, include the weight of the operator, accessories, loads in the rack or box and the load on the trailer tongue. The combined weight of these items must not exceed the maximum weight capacity.

CARGO WEIGHT DISTRIBUTION should be 1/3 on the front rack and 2/3 on the rear rack. When operating over rough or hilly terrain, reduce speed and cargo to maintain stable driving conditions. Carrying loads on only one rack increases the possibility of vehicle overturn.

CARRY LOADS AS LOW ON THE RACKS AS POSSIBLE. Carrying loads high on the racks raises the center of gravity of the vehicle and creates a less stable operating condition.

SECURE ALL LOADS BEFORE OPERATING. Unsecured loads can create unstable operating conditions, which could result in loss of control of the vehicle.

OPERATE ONLY WITH STABLE AND SAFELY ARRANGED LOADS. When handling off-centered loads that cannot be centered, securely fasten the load and operate with extra caution. Always attach the tow load to the hitch point designated for your vehicle.

HEAVY LOADS CAN CAUSE BRAKING AND CONTROL PROBLEMS. Use extreme caution when applying brakes with a loaded vehicle. Avoid terrain or situations that may require backing downhill.

USE EXTREME CAUTION when operating with loads that extend over the rack sides. Stability and maneuverability may be adversely affected, causing the vehicle to overturn.

DO NOT BLOCK THE FRONT HEADLIGHT BEAM when carrying loads on the front rack.

DO NOT TRAVEL FASTER THAN THE RECOMMENDED SPEEDS.

Vehicle should never exceed 10 MPH (16 km/h) while towing a load on a level surface. Vehicle speed should never exceed 5 MPH (8 km/h) when towing loads in rough terrain, while cornering, or while ascending or descending a hill.

Hauling Cargo

1. Never exceed the weight capacities specified for your ATV on warning labels and in the specifications section of this manual.
2. Cargo weight should be evenly distributed ($\frac{1}{3}$ on the front rack and $\frac{2}{3}$ on the rear rack) and mounted as low as possible.
3. When operating over rough or hilly terrain, reduce speed and cargo weight to maintain stable driving conditions.
4. Do not obstruct the headlight beam with cargo.
5. Use low forward gear when hauling or towing heavy cargo to extend belt life.

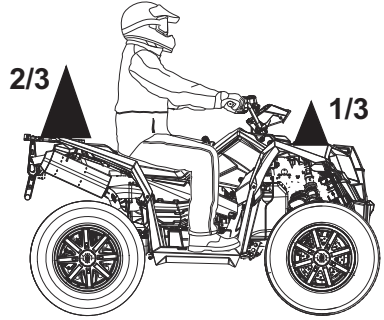

OPERATION

Hauling Cargo

Towing Loads

Always attach a towed load to the hitch point. Remove the hitch from the ATV when not towing a trailer. If towing a load, reduce rear rack cargo weight by the amount of tongue weight.

- The combination of rear rack cargo weight and tongue weight must not exceed the rear rack capacity.
- The total load (operator, accessories, cargo and weight on hitch) must not exceed the maximum weight capacity of the vehicle.

NOTICE: Using an improper hitch or exceeding the maximum tongue weight capacity can result in serious damage to the vehicle and will void your ATV warranty. Never install a hitch longer than 4" (10 cm). Never install automotive accessories on your POLARIS ATV. Always install POLARIS-approved (or equivalent) accessories designed for ATV use.

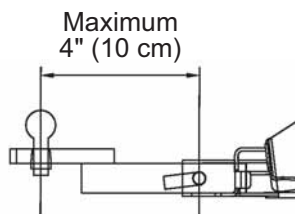

Maximum Towing Capacities

Do not exceed the following maximum capacities when towing. Avoid towing on inclines.

SCRAMBLER 850 XP/850 XP EPS	
Maximum Towed Load (Level Ground)	1500 lbs. (680 kg)
Maximum Vertical Hitch Weight	150 lbs. (68 kg)

EMISSION CONTROL SYSTEMS

Noise Emission Control System

Do not modify the engine, intake or exhaust components, as doing so may affect compliance with U.S.A. EPA noise control requirements (40 CFR 205) and local noise level requirements.

Operation on Public Lands in the U.S.A.

Your POLARIS vehicle has a spark arrester that was tested and qualified to be in accordance with the USFS standard 5100-1c. Federal law requires that this spark arrester be installed and functional when the vehicle is operated on public lands.

Operation of off-road vehicles on public lands in the U.S.A. is regulated by 43 CFR 420. Violations are subject to monetary penalties. Federal regulations can be viewed online at www.gpoaccess.gov/ecfr/.

Crankcase Emission Control System

This engine is equipped with a closed crankcase system. Blow-by gases are forced back to the combustion chamber by the intake system. All exhaust gases exit through the exhaust system.

Exhaust Emission Control System

Exhaust emissions are controlled by engine design. An electronic fuel injection (EFI) system controls fuel delivery. The engine and EFI components are set at the factory for optimal performance and are not adjustable.

The vehicle compliance labels can be found on the frame tubing of the vehicle.

Electromagnetic Interference

This spark ignition system complies with Canadian standard ICES-002.

This vehicle complies with the EMC requirements of European directives 97/24/EC and 2004/108/EC.

Non-ionizing Radiation: This vehicle emits some electromagnetic energy. People with active or non-active implantable medical devices (such as heart monitoring or controlling devices) should review the limitations of their device and the applicable electromagnetic standards and directives that apply to this vehicle.

MAINTENANCE

Periodic Maintenance Chart

Careful periodic maintenance will help keep your vehicle in safe, reliable condition. Inspect, clean, lubricate, adjust and replace parts as necessary. When inspection reveals the need for replacement parts, use genuine POLARIS parts available from your POLARIS dealer. Record maintenance and service in the Maintenance Log beginning on page 132.

Service and adjustments are important for proper vehicle operation. If you're not familiar with safe service and adjustment procedures, have a qualified dealer perform these operations.

Maintenance intervals in the following chart are based upon average riding conditions and an average vehicle speed of approximately 10 miles per hour. Vehicles subjected to severe use must be inspected and serviced more frequently.

Severe Use Definition

- Frequent immersion in mud, water or sand
- Racing or race-style high RPM use
- Prolonged low speed, heavy load operation
- Extended idle
- Short trip cold weather operation

Pay special attention to the oil level. A rise in oil level during cold weather can indicate contaminants collecting in the oil sump or crankcase. Change oil immediately if the oil level begins to rise. Monitor the oil level, and if it continues to rise, discontinue use and determine the cause or see your dealer.

MAINTENANCE

Periodic Maintenance Chart Maintenance Chart Key

Symbol	Description
▶	Perform these operations more often for vehicles subjected to severe use.
E	Emission-related service (failure to conduct this maintenance will not void the emissions warranty but may affect emissions)
D	Have an authorized POLARIS dealer perform these services.

WARNING! Improperly performing the procedures marked with a “D” could result in component failure and lead to serious injury or death. Have an authorized POLARIS dealer perform these services.

Perform all services at whichever maintenance interval is reached first.

Item	Maintenance Interval (whichever comes first)			Remarks
	Hours	Calendar	Miles (Km)	
▶ Steering	-	Pre-Ride	-	See Pre-Ride Checklist on page 54.
▶ Front suspension	-	Pre-Ride	-	
▶ Rear suspension	-	Pre-Ride	-	
▶ Tires	-	Pre-Ride	-	
▶ Brake fluid level	-	Pre-Ride	-	
▶ Brake lever travel	-	Pre-Ride	-	
▶ Brake system	-	Pre-Ride	-	
▶ Wheels/fasteners	-	Pre-Ride	-	
▶ Frame fasteners	-	Pre-Ride	-	
▶ Engine oil level	-	Pre-Ride	-	
▶ E Air filter, pre-filter	-	Daily	-	Inspect; clean often; replace as needed
▶ Coolant	-	Daily	-	Check level daily, change coolant every 2 years
▶ Power steering unit (if equipped)	-	Daily	-	Inspect daily; clean often
▶ Headlamp/taillight	-	Daily	-	Check operation

MAINTENANCE

Periodic Maintenance Chart

	Item	Maintenance Interval (whichever comes first)			Remarks
		Hours	Calendar	Miles (Km)	
▶ E	Air filter, main element	-	Weekly	-	Inspect; replace as needed
▶	Brake pad wear	10 H	Monthly	100 (160)	Inspect periodically
	Battery	20 H	Monthly	200 (320)	Check terminals; clean; test
▶	Engine oil change	25 H	1 M	250 (400)	Break-in oil and filter change (see page 52)
▶	Demand drive fluid	25 H	1 M	250 (400)	Break-in oil level check
▶	Rear gearcase oil	25 H	1 M	250 (400)	Break-in oil level check
▶	Transmission oil	25 H	1 M	250 (400)	Break-in oil level check
▶	General lubrication	50 H	3 M	500 (800)	Lubricate all fittings, pivots, cables, etc.
	Shift linkage	50 H	6 M	500 (800)	Inspect, lubricate
D	Steering	50 H	6 M	500 (800)	Lubricate
▶	Front suspension	50 H	6 M	500 (800)	Lubricate
▶	Rear suspension	50 H	6 M	500 (800)	Lubricate
E	Throttle Cable/ Release Switch	50 H	6 M	500 (800)	Inspect; adjust; lubricate; replace if necessary
E	Throttle Body Intake Duct	50 H	6 M	500 (800)	Inspect duct for proper seal- ing/air leaks
	Drive belt	50 H	6 M	500 (800)	Inspect; replace as needed
	Cooling system	50 H	6 M	1000 (1600)	Inspect coolant strength seasonally; pressure test system yearly
▶	Radiator	50 H	6 M	1000 (1600)	Inspect; clean external surfaces
▶	Cooling hoses	50 H	6 M	1000 (1600)	Inspect for leaks
▶	Engine oil change	100 H	6 M	1000 (1600)	Change the oil and filter
▶	Demand drive fluid (normal use)	100 H	12 M	1000 (1600)	Change fluid
▶	Rear gearcase oil	100 H	12 M	1000 (1600)	Change fluid
▶	Transmission oil	100 H	12 M	1000 (1600)	Change fluid

▶ Perform these procedures more often for vehicles subjected to severe use.

E Emission-Related Service

D Have an authorized POLARIS dealer perform these services.

MAINTENANCE

Periodic Maintenance Chart

	Item	Maintenance Interval (whichever comes first)			Remarks
		Hours	Calendar	Miles (Km)	
	Fuel system	100 H	12 M	1000 (1600)	Check for leaks at tank cap, lines, filter, pump; replace lines every two years
▶	Engine mounts	100 H	12 M	1000 (1600)	Inspect
	Exhaust muffler/ pipe	100 H	12 M	1000 (1600)	Inspect
D E	Spark plug	100 H	12 M	1000 (1600)	Inspect; replace as needed
▶	Wiring	100 H	12 M	1000 (1600)	Inspect for wear, routing, security; apply dielectric grease to connectors subjected to water, mud, etc.
D	Clutches (drive and driven)	100 H	12 M	1000 (1600)	Inspect; clean; replace worn parts
D	Front wheel bearings	100 H	12 M	1000 (1600)	Inspect; replace as needed
D	Brake fluid	200 H	24 M	2000 (3200)	Change every two years
	Spark arrester	300 H	36 M	3000 (4800)	Clean out
D E	Valve clearance	1000 H	-	10000 (16000)	Inspect; adjust
D	Toe adjustment	-			Inspect periodically; adjust when parts are replaced
	Headlight aim	-			Adjust as needed

MAINTENANCE

Lubrication Guide

Check and lubricate all components at the intervals outlined in the Periodic Maintenance Chart beginning on page 73. Items not listed in the chart should be lubricated at the General Lubrication interval.

The a-arms and lower control arms are lubricated at the factory, and no additional lubrication will be needed. However, if these components are subjected to severe use, grease zerks have been provided for additional lubrication at the user's discretion.

Item	Recommended Lubricant	Capacity at Fluid Change	Fill Plug Torque	Drain Plug Torque	Inspection Procedure
Engine Oil	PS-4 PLUS Performance Synthetic 2W-50	2 qt. (1.9 l)	---	12 ft. lbs. (16 Nm)	Page 77.
Transmission Oil	AGL PLUS Transmission Fluid	37 oz. (1100 ml)	10-14 ft. lbs. (14-19 Nm)	10-14 ft. lbs. (14-19 Nm)	Page 80.
Demand Drive Fluid (Front Gearcase)	Demand Drive Plus Fluid	9.3 oz. (275 ml)	8-10 ft. lbs. (11-14 Nm)	11 ft. lbs. (15 Nm)	Page 81.
Rear Gearcase Oil	ATV Angle Drive Fluid (or GL5 80-90 weight gear lube)	7.1 oz. (210 ml)	10-14 ft. lbs. (14-19 Nm)	10-14 ft. lbs. (14-19 Nm)	Page 82.
Brake Fluid	DOT 4 Only	---	---	---	Page 28.
Front Prop Shaft Yoke	POLARIS Premium U-Joint Lube	Grease fittings (3 pumps maximum) every 500 miles, before long periods of storage, or after pressure washing or submerging.			
A-Arms, Front and Rear	POLARIS Premium All-Season Grease	Grease fittings after extreme use or if suspension becomes squeaky.			

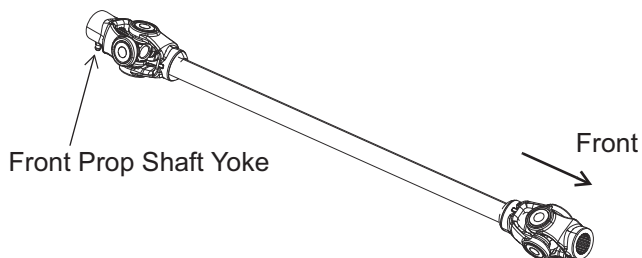

Engine Oil

Oil Recommendations

POLARIS recommends the use of POLARIS PS-4 *PLUS Performance* Synthetic 2W-50 4-cycle oil or a similar oil for this engine. See the table on page 76 for fluid recommendations, capacities and plug torques.

Oil may need to be changed more frequently if POLARIS oil is not used. Always use 2W-50 oil. Follow the manufacturer's recommendations for ambient temperature operation. See page 121 for the part numbers of POLARIS products.

NOTICE: Mixing brands or using a non-recommended oil may cause serious engine damage. Always use the recommended oil. Never substitute or mix oil brands.

Oil Level

Check the oil level when the engine is cold. *Never check the oil with the engine running.*

1. Position the vehicle on a level surface.
2. Access the oil dipstick and fill tube from the left side of the ATV. Remove the dipstick. Wipe it dry with a clean cloth.
3. Reinstall and tighten the dipstick.
4. Remove the dipstick and check the oil level.
5. Add the recommended fluid as needed. Maintain the oil level in the safe range between the FULL and ADD marks. Do not overfill.
6. Reinstall and tighten the dipstick.

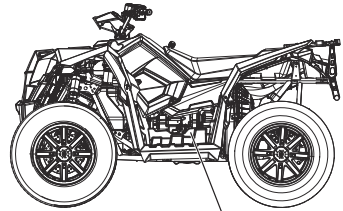

Dipstick

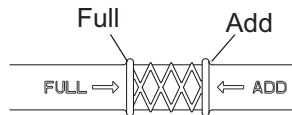

MAINTENANCE

Engine Oil

Oil and Filter Change

See the table on page 76 for fluid recommendations, capacities and plug torques. Always change the oil and filter at the intervals outlined in the Periodic Maintenance Chart beginning on page 73. Always change the oil filter whenever changing oil.

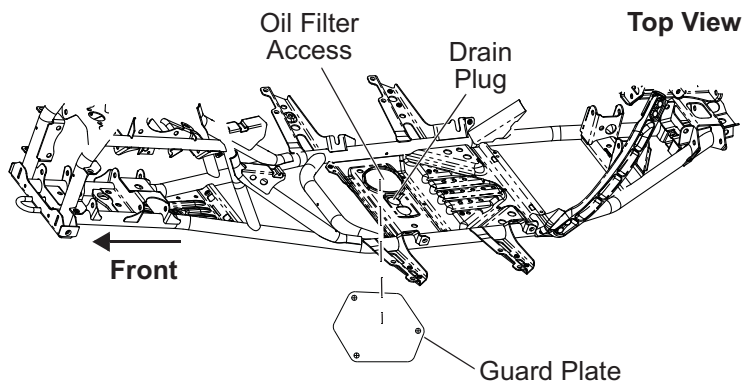

1. Position the vehicle on a level surface.
2. Start the engine. Allow it to warm up at idle for two to three minutes.
3. Stop the engine.
4. On the bottom of the vehicle, a guard plate covers the oil filter access hole. Remove the three bolts securing the guard plate and remove the guard plate.
5. Clean the area around the drain plug.
6. Place a drain pan under the crankcase.
7. Remove the drain plug. Allow the oil to drain completely.

CAUTION! Hot oil can cause burns to skin. Do not allow hot oil to contact skin.

8. Install a new sealing washer on the drain plug. The sealing surfaces on drain plug and crankcase should be clean and free of burrs, nicks or scratches.
9. Reinstall the drain plug. Torque to specification.

Engine Oil Oil and Filter Change

10. Place shop towels beneath the oil filter. Using an oil filter wrench (available from your POLARIS dealer), turn the filter counter-clockwise to remove it.
11. Using a clean dry cloth, clean the filter sealing surface on the crankcase.
12. Lubricate the o-ring on the new filter with a film of fresh engine oil. Check to make sure the o-ring is in good condition.
13. Install the new filter and rotate it clockwise by hand until the filter gasket contacts the sealing surface, then turn it an additional 1/2 turn.
14. Remove the dipstick. Add the proper amount of the recommended oil. Do not overfill.
15. Reinstall the dipstick.
16. Reinstall the guard plate over the filter access hole.
17. Place the transmission in PARK.
18. Lock the parking brake.
19. Start the engine. Allow it to idle for one to two minutes.
20. Stop the engine.
21. Check for leaks.
22. Check the oil level. Add oil as needed to bring the level to the upper mark on the dipstick.
23. Dispose of used filter and oil properly.

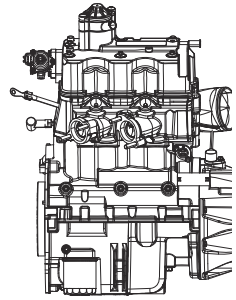

Oil Filter

MAINTENANCE

Transmission Oil

POLARIS recommends the use of POLARIS AGL PLUS Transmission Fluid for this transmission. See the table on page 76 for fluid recommendations, capacities and plug torques. Always check and change the transmission oil at the intervals outlined in the Periodic Maintenance Chart beginning on page 73. See page 121 for the part numbers of POLARIS products.

Maintain the oil level at the bottom of the fill plug hole. The fill plug is located on the right side of the ATV behind the footwell. The drain plug is located on the bottom rear of the gearcase.

Oil Check

1. Remove the footwell (see page 89).
2. Remove the fill plug. Check the oil level.
3. Add the recommended fluid as needed to bring the level to the bottom of the fill hole threads.
4. Reinstall the fill plug. Torque to specification.
5. Reinstall the footwell.

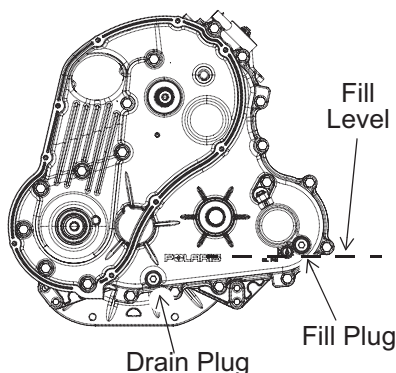

Oil Change

1. Remove the footwell.
2. Place a drain pan under the gearcase. Remove the drain plug. Allow the oil to drain completely.
3. Clean and reinstall the drain plug. Torque to specification.
4. Remove the fill plug. Add the proper amount of the recommended oil.
5. Reinstall the fill plug. Torque to specification.
6. Check for leaks.
7. Reinstall the footwell.
8. Dispose of used oil properly.

MAINTENANCE

Front Gearcase (Demand Drive) Fluid

See the table on page 76 for fluid recommendations, capacities and plug torques. Always check and change the demand drive fluid at the intervals outlined in the Periodic Maintenance Chart beginning on page 73. See page 121 for the part numbers of POLARIS products.

Use the recommended fluid. Use of other fluids may result in improper operation of components. Maintain the fluid level at the bottom of the fill hole threads. The fill plug is located on the right side of the demand drive unit. The drain plug is located on the bottom right side of the unit.

Fluid Check

1. Position the vehicle on a level surface. Remove the fill plug. Check the fluid level.
2. Add the recommended fluid as needed to bring the level to the bottom of the fill hole threads.
3. Reinstall the fill plug. Torque to specification.

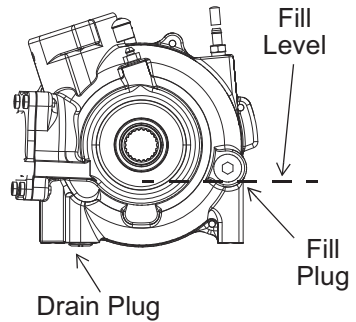

Fluid Change

1. Position the vehicle on a level surface. Remove the fill plug.
2. Place a drain pan under the demand drive unit. Remove the drain plug. Allow the fluid to drain completely.
3. Clean and reinstall the drain plug. Torque to specification.
4. Add the proper amount of the recommended fluid.
5. Reinstall the fill plug. Torque to specification.
6. Check for leaks. Dispose of used fluid properly.

MAINTENANCE

Rear Gearcase Oil

See the table on page 76 for fluid recommendations, capacities and plug torques. Always check and change the rear gearcase oil at the intervals outlined in the Periodic Maintenance Chart beginning on page 73. See page 121 for the part numbers of POLARIS products.

The fill plug is located on the rear of the gearcase. The drain plug is located on the bottom of the gearcase.

Maintain the fluid level at the bottom of the fill hole threads. Do not overfill.

Oil Check

1. Position the vehicle on a level surface.
2. Remove the fill plug. Check the oil level.
3. Add the recommended oil as needed to bring the level to the bottom of the fill hole threads. *Do not overfill.*
4. Reinstall the fill plug. Torque to specification.

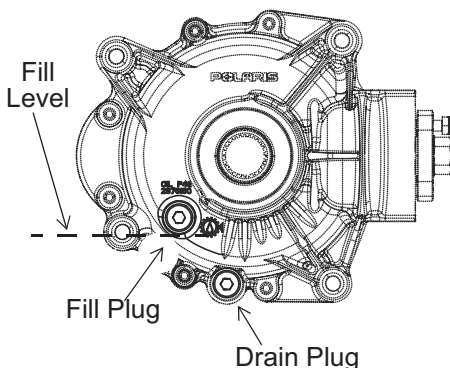

Rear Gearcase Oil Oil Change

1. Position the vehicle on a level surface.
2. Place a drain pan under the drain hole.
3. Remove the drain plug. Allow the oil to drain completely.
4. Clean and reinstall the drain plug with a new sealing washer. Torque to specification.
5. Remove the fill plug. Add the proper amount of the recommended oil. *Do not overfill.*
6. Reinstall the fill plug. Torque to specification.
7. Check for leaks.
8. Dispose of used oil properly.

MAINTENANCE

Power Steering Unit

If your model is equipped with power steering, frequently clean the areas around and on the power steering unit to allow proper cooling. Clean these areas thoroughly.

Clean
Often

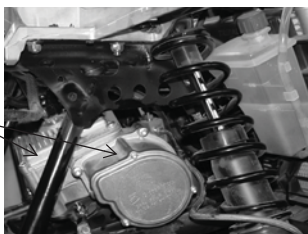

Steering Assembly

The steering assembly of the ATV should be checked periodically for loose nuts and bolts. If loose nuts and bolts are found, see your POLARIS dealer for service before operating the vehicle.

Cooling System

The engine coolant level is controlled by the recovery system. Recovery system components are the recovery bottle, the radiator filler neck, the radiator pressure cap and the connecting hose.

As coolant operating temperature increases, the expanding (heated) excess coolant is forced out of the engine, past the pressure cap, and into the recovery bottle. As engine coolant temperature decreases the contracting (cooled) coolant is drawn back up from the bottle, past the pressure cap, and into the radiator.

Some coolant level drop on new vehicles is normal as the system is purging itself of trapped air. Check the coolant level and maintain as recommended by adding coolant to the recovery bottle.

POLARIS recommends the use of POLARIS Premium 60/40 anti-freeze/coolant or a 50/50 mixture of high quality aluminum compatible anti-freeze/coolant and distilled water. POLARIS Premium 60/40 is already premixed and ready to use. Do not dilute with water. See page 121 for the part numbers of POLARIS products.

Always follow the manufacturer's mixing recommendations for the freeze protection required in your area.

Cooling System Recovery Bottle Coolant

The recovery bottle fluid level can be viewed from inside the front right wheel well. Access the recovery bottle cap under the front storage compartment.

1. View the fluid level in the bottle.
2. If the level is low, remove the front rack.
3. Remove the bottle cap and add coolant as needed. Maintain the coolant level between the minimum and maximum marks on the bottle (when the fluid is cool).
4. Reinstall the cap.
5. Reinstall the front rack.



Coolant Bottle Cap



Maximum
Mark

Minimum
Mark

MAINTENANCE

Cooling System

Radiator Coolant

To ensure that the coolant maintains its ability to protect the engine, POLARIS recommends that you drain the system completely every two years and add a fresh mixture of antifreeze and water.

Replace the coolant any time the cooling system has been drained for maintenance or repair. If the recovery bottle has run dry, check the level in the radiator. Add coolant as needed.

CAUTION! Escaping steam can cause burns. Never remove the pressure cap while the engine is warm or hot. Always allow the engine to cool before removing the pressure cap.

1. Remove the front rack.
2. Remove the pressure cap.
3. Using a funnel, slowly add coolant through the radiator filler neck.
4. Reinstall the pressure cap. Use of a non-standard pressure cap will not allow the recovery system to function properly. Contact your dealer for the correct replacement part.
5. Reinstall the front rack.



Radiator
Cap

Brakes

Hand Brake

The front and rear brakes are hydraulic disc brakes, activated by moving the single brake lever toward the handlebar. These brakes are self-adjusting.

Under normal operation, the diaphragm extends into the reservoir as fluid level drops. If the fluid level is low and the diaphragm is not extended, a leak is likely and the diaphragm should be replaced. To ensure proper diaphragm operation, always fill the reservoir as needed whenever the cover is loosened or removed. Do not overfill.

WARNING! An over-full master cylinder may cause brake drag or brake lock-up, which could result in serious injury or death. Maintain brake fluid at the recommended level. Do not overfill.

The following checks are recommended to keep the brake system in good operating condition. Check more often if brakes are used heavily under normal operation.

1. Always keep brake fluid at an adequate level. See page 28.
2. Check the brake system for fluid leaks.
3. Check the brakes for excessive travel or spongy feel.
4. Check the friction pads for wear, damage and looseness. Replace brake pads when they are worn to $3/64$ " (1 mm).
5. Check the security and surface condition of the disc. Clean any grease using a recommended brake cleaner or alcohol. Do not use spray lubricants or other petroleum-based products. If you discover any damage (cracks, excessive corrosion, warping) see your dealer for service before operating.

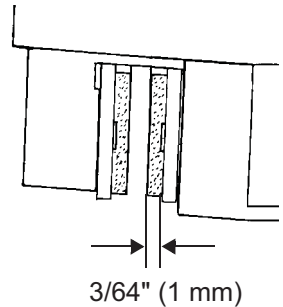

Auxiliary Foot Brake

The hydraulic auxiliary brake system requires no adjustment. Check the brake fluid level frequently for the auxiliary brake system. See page 30.

MAINTENANCE

Toe Alignment

Use the following procedure to check the toe alignment of the vehicle. The recommended toe alignment is 1/4-1/2 inch (6-12 mm) toe out.

WARNING! Severe injury or death can result from improper toe alignment and adjustment. Do not attempt to adjust tie rod alignment. All tie rod adjustments should be performed by an authorized POLARIS dealer.

1. Position the vehicle on a level surface.
2. Place the handlebars in a straight-ahead position.
3. Tie a length of string between two stands as shown in the illustration. Position the stands so that the string is flush with the side of the rear tire. If available, you may use a long straight-edge instead of string.
4. Measure the distance from the string to the rim at the front (1) and rear (2) of the front rim.

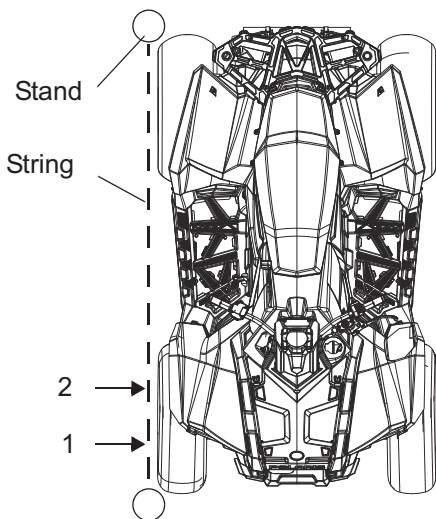

The rear measurement should be 1/8-1/4 inch (3-6 mm) more than the front measurement on each side of the vehicle to obtain the recommended 1/4-1/2 inch (6-12 mm) toe out alignment.

5. Repeat the measurement procedure on the other side of the vehicle.
6. If you discover improper alignment, see your POLARIS dealer for service.

Steering Assembly

The steering assembly of the ATV should be checked periodically for loose nuts and bolts. If loose nuts and bolts are found, see your POLARIS dealer for service before operating the vehicle.

Seat Removal

1. Grasp one side of the seat near the rear edge.
2. Pull upward abruptly to disengage the under-seat fasteners.
3. Remove the seat.

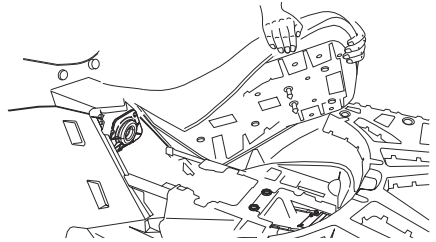

Side Panel/Footwell Removal

Remove the seat before removing a side panel. To remove a side panel or footwell, remove the fasteners securing it to the frame. Lift the right side panel upward while removing it to clear the shifter knob.

Plastic Rivets

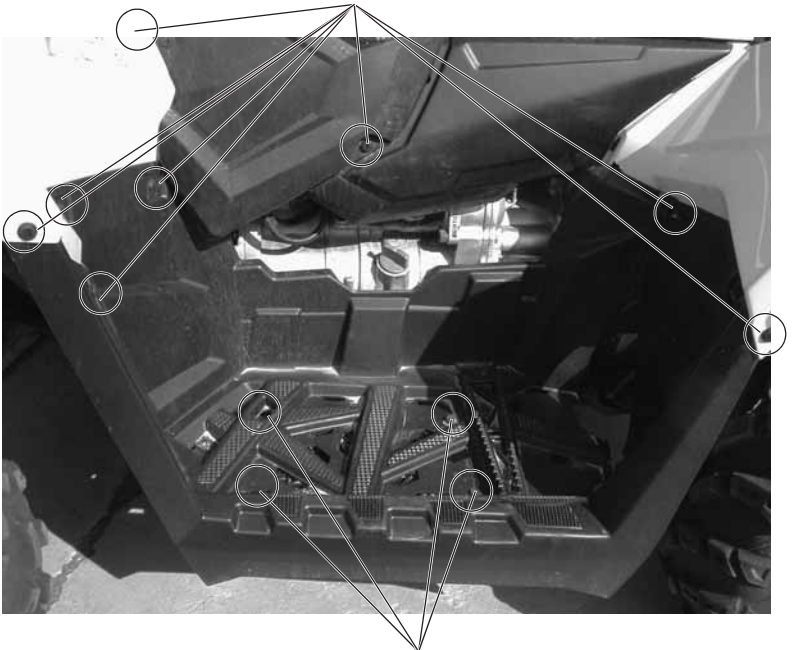

Hex Head Screws

MAINTENANCE

Tires

⚠ WARNING

Operating your ATV with worn tires, improperly inflated tires, non-standard tires or improperly installed tires will affect vehicle handling and could cause an accident resulting in serious injury or death. Always follow all tire maintenance procedures as outlined in this manual and on the labels on the vehicle. Always use original equipment size and type when replacing tires.

Refer to the specifications section beginning on page 121 for recommended tire type, size and pressure.

Tire Tread Depth

Always replace tires when tread depth is worn to 1/8" (3 mm) or less.

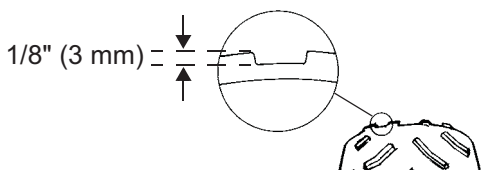

Front Wheel Hub Tightening

Front wheel bearing tightness and spindle nut retention are critical component operations. All service must be performed by your authorized POLARIS dealer.

Wheel Removal

1. Stop the engine.
2. Place the transmission in PARK.
3. Lock the parking brake.
4. Loosen the wheel nuts slightly.

WARNING! Do not service axle nuts that have a cotter pin installed. See your POLARIS dealer.

5. Elevate the side of the vehicle by placing a suitable stand under the footrest frame.
6. Remove the wheel nuts.
7. Remove the wheel.

Tires

Wheel Installation

1. Place the transmission in PARK.
2. Lock the parking brake.
3. Place the wheel on the hub with the valve stem toward the outside and rotation arrows on the tire pointing toward forward rotation (if equipped).
4. Install the wheel nuts and finger-tighten them.
5. Lower the vehicle to the ground.
6. Torque the wheel nuts to specification.

WARNING! Loose nuts could cause a tire to come off during operation, which could result in an accident or overturn. Always ensure that all nuts are torqued to specification.



Cast Aluminum

75 ft. lbs.
(102 Nm)



Steel

45 ft. lbs.
(61 Nm)

Wheel Nut Torque Specifications

Check the wheel nut torques occasionally and when they've been loosened for maintenance service. When servicing cast aluminum wheels, use either a *thin-walled impact socket* or a *standard non-impact socket* to remove and torque lug nuts.

Wheel Type	Nut Type	Nut Torque
Aluminum	Lug Nut	75 ft. lbs. (102 Nm)
Steel	Lug Nut	45 ft. lbs. (61 Nm)

MAINTENANCE

Air Filter

1. Remove the seat.
2. Remove the air box cover strap, and remove the air box cover.
3. Remove the filter.
4. Remove the fabric type pre-filter from the main filter. Wash the pre-filter in soapy water, then rinse and let dry.
5. Reinstall the pre-filter over the main filter. Install a new main filter if needed.
6. Reinstall the filter into the air box.
7. Reinstall the air box cover and the seat.

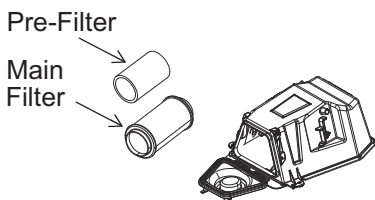
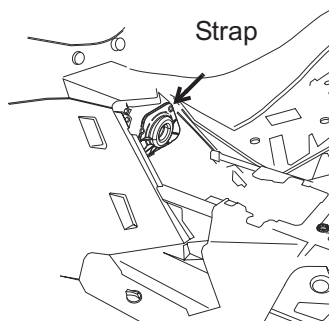

Fuse Replacement

If the engine stops or will not start, or if you experience other electrical failures, a fuse may need replacement. Locate and correct any short circuits that may have caused the blown fuse, then replace the fuse.

1. Remove the front rack.
2. Remove the fuse box cover.
3. Remove the suspect fuse from the fuse panel. If the fuse is blown, install a new fuse with the same amperage rating.
4. Reinstall the fuse box cover.
5. Reinstall the front rack.

START SOLENOID RELAY	FAN RELAY	EFI RELAY	LOW BEAM RELAY	S P A R E
CHASSIS RELAY	LIGHTS 20A	DRIVE 20A	ACCESSORY 20A	
	EFI 20A	UNSWITCH 10A	SPARE 20A	S P A R E

SCRAMBLER 850 XP

START SOLENOID RELAY	FAN RELAY	EFI RELAY	EPS RELAY	S P A R E
CHASSIS RELAY	LIGHTS 20A	DRIVE 20A	ACCESSORY 20A	
	EFI 20A	UNSWITCH 10A	EPS 30A	S P A R E

SCRAMBLER 850 XP EPS

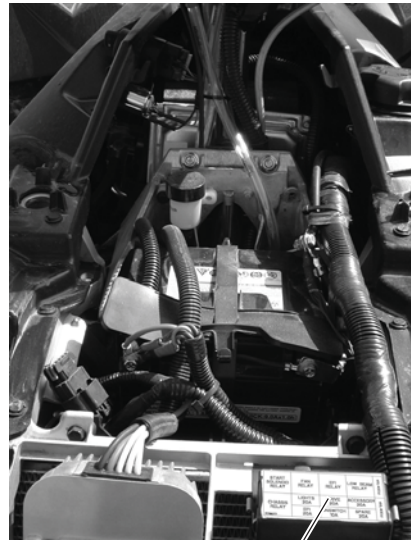

Fuse Box

MAINTENANCE

Lights

Poor lighting can result in reduced visibility when driving. Headlight and taillight lenses become dirty during normal operation. Clean lights frequently and replace burned out lamps promptly. Always make sure lights are adjusted properly for best visibility.

Headlight Beam Inspection

The headlight beam can be adjusted slightly. Use the following procedure to make the adjustment.

1. Position the vehicle on a level surface with the headlight approximately 25 ft. (7.6 m) from a wall. Place the transmission in PARK.

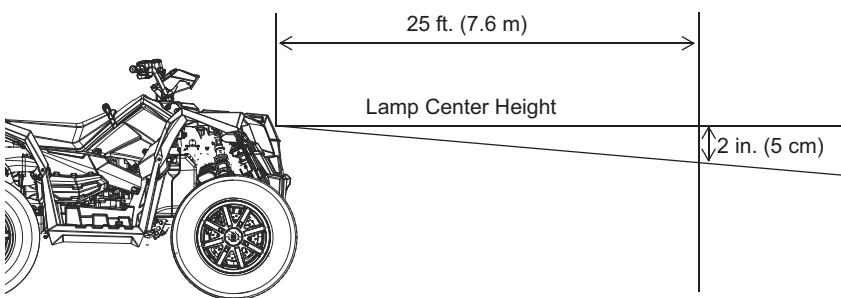

2. Measure the distance from the floor to the center of the headlight and make a mark on the wall at the same height.
3. Start the engine. Turn the headlight switch to high beam.
4. Observe the headlight aim on the wall. The most intense part of the headlight beam should be two inches (5 cm) below the mark on the wall. Include rider weight on the seat when measuring.

Headlight Beam Adjustment (XP EPS)

The headlight beam can be adjusted horizontally and vertically.

Tighten or loosen the one or more of the three headlight adjustment screws to adjust the beam upward or downward or to the left or right.

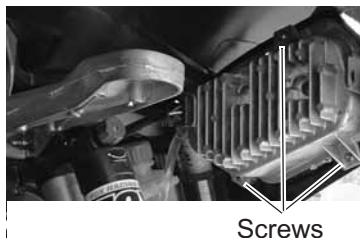

Lights

Headlight Beam Adjustment (XP)

The headlight beam can be adjusted vertically.

1. Loosen the phillips screw located at the rear of the headlamp.
2. Tilt the headlamp upward or downward.
3. Tighten the screw.

Phillips Screw



Headlamp Replacement (XP)

1. Turn the back of the headlight harness counter-clockwise and pull the harness assembly away from the headlight assembly.
2. Remove the headlamp and install the new headlamp.
3. Reinstall the harness assembly into the headlight assembly.
4. Turn the headlight harness clockwise to secure the headlamp.

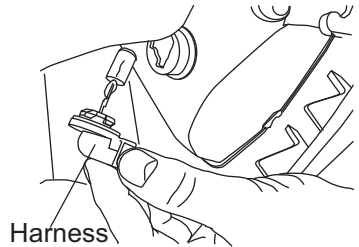

Headlamp Replacement (XP EPS)

If a headlight becomes damaged or inoperable, the entire headlight assembly must be replaced.

Taillight/Brakelight Lamp Replacement

The taillight assembly is not serviceable. If the light fails to operate properly, replace the entire taillight assembly.

MAINTENANCE

Spark Plugs

Spark Plug Recommendations

Refer to the specifications section beginning on page 121 for the recommended spark plug type and gap for your vehicle. Torque spark plugs to specification.

NOTICE: Using non-recommended spark plugs can result in serious engine damage. Always use POLARIS-recommended spark plugs.

Torque Specification	
New Spark Plug	18-20 ft. lbs. (24-27 Nm)
Previously Installed Spark Plug	18-20 ft. lbs. (24-27 Nm)

Spark Plug Inspection

Spark plug condition is indicative of engine operation. Check the spark plug firing end condition after the engine has been warmed up and the vehicle has been driven at higher speeds. Immediately check the spark plugs for correct color. See page 97.

CAUTION! A hot exhaust system and engine can cause burns. Wear protective gloves when removing a spark plug for inspection.

1. Rotate the spark plug cap 1/4 turn and pull it off the spark plug.
2. Rotate the spark plug counter-clockwise to remove it.
3. Reverse the procedure for spark plug installation. Torque to specification.

Spark Plugs

Spark Plug Inspection

Normal Spark Plug

The normal insulator tip is gray, tan or light brown. There will be few combustion deposits. The electrodes are not burned or eroded. This indicates the proper type and heat range for the engine and the service.

The tip should not be flaky and white. A white insulator tip indicates overheating, caused by use of an improper spark plug or incorrect fuel.

Wet Fouled Spark Plug

The wet fouled insulator tip is black. A damp oil film covers the firing end. There may be a carbon layer over the entire nose. Generally, the electrodes are not worn. General causes of fouling are excessive oil, use of non-recommended oil or incorrect throttle body adjustments.

MAINTENANCE

Vehicle Immersion

If your vehicle becomes immersed, major engine damage can result if the machine is not thoroughly inspected. Take the vehicle to your dealer before starting the engine. If it's impossible to take your ATV to a dealer before starting it, follow the steps outlined below.

1. Move the ATV to dry land or at the very least, to water below the footrests.
2. Check the air box. If water is present, dry the air box and replace the filter with a new filter. If equipped, remove the air box drain plug to drain water. Reinstall the drain plug.
3. Remove the spark plugs.
4. Turn the engine over several times using the electric start.
5. Dry the spark plugs. Reinstall the plugs or install new plugs.
6. Attempt to start the engine. If necessary, repeat the drying procedure.

NOTICE: Serious damage can occur after immersion if fluids are not changed promptly. See your dealer as recommended.

7. Take the ATV to your dealer for service as soon as possible, whether you succeed in starting it or not.
8. If water has been ingested into the PVT, follow the procedure on page 102 for drying out the PVT.

Spark Arrester

⚠ WARNING

Failure to heed the following warnings while servicing the spark arrester could result in serious injury or death. Never run the engine in an enclosed area. Remove any combustible materials from the area. Wear eye protection and leather work gloves. Do not stand behind or in front of the vehicle while purging. Never go under the vehicle while it's inclined.

The exhaust system can get extremely hot. Do not perform service on the spark arrester while the system is hot. Allow components to cool sufficiently before proceeding.

Periodically clean the spark arrester to remove accumulated carbon.

1. Remove the retaining nut. Remove the arrester from the end of the muffler.
2. Use a non-synthetic brush to clean the arrester screen. A synthetic brush may melt if components are warm. If necessary, blow debris from the screen with compressed air.
3. Inspect the screen for wear and damage. Replace a worn or damaged screen.
4. Reinstall the arrester. Torque the nut to 7-9 ft. lbs. (10-12 Nm).

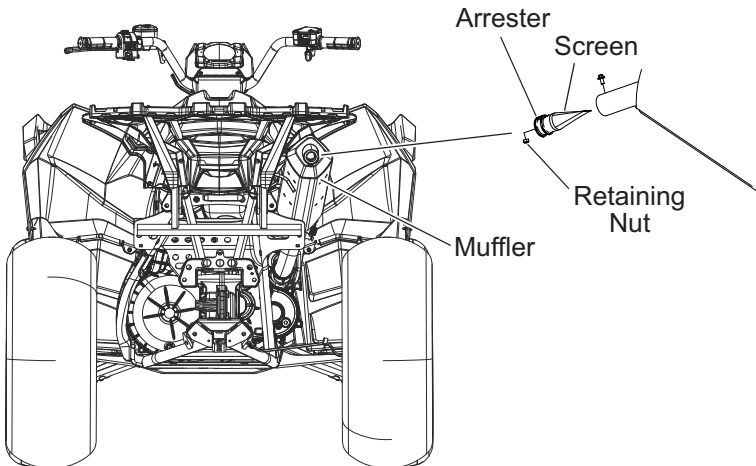

MAINTENANCE

PVT System

WARNING

Failure to comply with the instructions in this warning can result in severe injury or death.

Do not modify any component of the PVT system. Doing so may reduce its strength so that a failure may occur at a high speed. The PVT system has been precision balanced. Any modification will cause the system to be out of balance, creating vibration and additional loads on components.

The PVT system rotates at high speeds, creating large amounts of force on clutch components. Extensive engineering and testing has been conducted to ensure the safety of this product. However, as the owner, you have the following responsibilities to make sure this system remains safe:

- Always follow all recommended maintenance procedures. Always look for and remove debris inside and around the clutch and vent system when replacing the belt.
- See your dealer as outlined in the owner's manual.
- This PVT system is intended for use on POLARIS products only. Do not install it in any other product.
- Always make sure the PVT housing is securely in place during operation.

PVT System

The basic operation of the POLARIS PVT system is dependent on engine speed and vehicle torque requirements. As engine speed increases, the force exerted on the movable drive sheave by the flyweights also increases. This, in turn, increases the amount of pinch applied to the drive belt. Similarly, if the engine speed decreases, the amount of centrifugal force decreases, reducing the amount of belt pinch.

On POLARIS ATVs, the approximate gear ratio difference between high and low range is 1:2.25. This difference in gearing affects the operation of the PVT, especially at speeds less than 7 MPH (11 km/h), due to the system's dependence on engine speed.

For example, when operating at a ground speed of 3 MPH (5 km/h) in low range, the engine speed would be around 3000 RPM. This is well above the engagement speed of 1600 - 1800 RPM. However, in high range at 3 MPH (5 km/h), the engine would be running at only 1500 RPM. Whenever operating this close to the engagement speed, the engine may be running at a speed too low to provide the pinch needed to prevent belt slip. Belt slip is responsible for creating the excessive heat that destroys belts, wears clutch components and causes outer clutch covers to fail.

The air temperature in the clutch cover is substantially reduced by using low range while operating at low ground speeds. Reducing the temperature inside the clutch cover greatly extends the life of the PVT components (belt, cover, etc.).

MAINTENANCE

PVT System

When To Use Low Range and High Range

Condition	Range to Use
Operating at speeds less than 7 MPH (11 km/h)	Low
Towing heavy loads	Low
Operating in rough terrain (swamps, mountains, etc.)	Low
Operating at speeds greater than 7 MPH (11 km/h)	High

PVT Drying

There may be some instances when water is accidentally ingested into the PVT system. Use the following instructions to dry it out before operating.

1. Position the vehicle on a level surface.
2. Remove the drain plug. Allow the water to drain completely. Reinstall the drain plug.
3. Start the engine. Place the transmission in PARK.
4. Apply varying throttle for 10-15 seconds to expel the moisture and air-dry the belt and clutches. Do not hold the throttle wide open for more than 5 seconds.
5. Allow the engine RPM to settle to idle speed, then shift the transmission to the lowest available range.
6. Test for belt slippage. If the belt slips, repeat the process.
7. Take the vehicle to your dealer for service as soon as possible.

Handlebars

The handlebars can be adjusted for rider preference.

WARNING! Improper adjustment of the handlebars or incorrect torquing of the adjuster block tightening bolts can cause limited steering or loosening of the handlebars, resulting in loss of control and serious injury or death. Follow the adjustment procedures exactly, or see your POLARIS dealer for service.

1. Remove the upper headlight pod.
2. Loosen the four handlebar bolts.
3. Adjust the handlebar to the desired height. Be sure the handlebars do not contact the gas tank or any other part of the machine when turned fully to the left or right.
4. Torque the front two bolts to 10-12 ft. lbs. (14-17 Nm), then torque the rear two bolts. A gap of up to 1/8" (3 mm) will remain at the rear of the clamp blocks.

MAINTENANCE

Camber and Caster

The camber and caster are non-adjustable.

Front/Rear Springs (XP)

The front and rear shock absorber springs are adjusted by rotating the adjuster either clockwise or counter-clockwise to increase or decrease spring tension. Accessory springs are available through your POLARIS dealer.



Adjuster

MAINTENANCE

Front/Rear Shock Compression (XP EPS)

The compression damping clicker knob is located on top of the shock reservoir. When the knob is turned clockwise until it stops, the damping is in the fully closed position.

FOX Shocks	
Setting	Compression Damping
Softest	20 clicks from closed
Factory	10 clicks from closed
Firmer	2 clicks from closed

1. Turn the clicker clockwise to increase compression damping.
2. Turn the clicker counter-clockwise to decrease compression damping.



Front

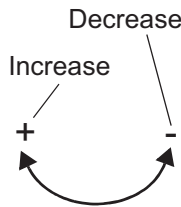

Rear

MAINTENANCE

Throttle Body/Idle RPM

Idle RPM is preset by the manufacturer. If the engine idle speed is not satisfactory, please see your POLARIS dealer for adjustment.

Throttle Cable Freeplay

1. Remove the four cover screws from the right handlebar control and remove the cover.
2. With the handlebars straight ahead, place very light pressure on the throttle lever. A gap of 2-3 mm should be visible between the throttle arm stop pin and the throttle arm.

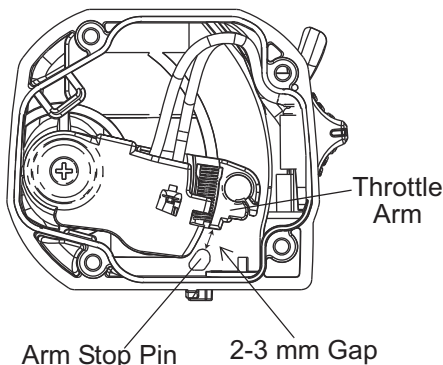

If adjustment is needed:

1. Locate the throttle cable adjuster. Squeeze the end of the rubber boot and slide it back far enough to expose the inline cable adjuster locknut.
2. Loosen the adjuster locknut.
3. Rotate the boot to turn the adjuster until 2-3 mm of freeplay is achieved between the stop pin and the throttle arm. *While adjusting freeplay, flip the throttle lever back and forth repeatedly.*

(continued on next page)

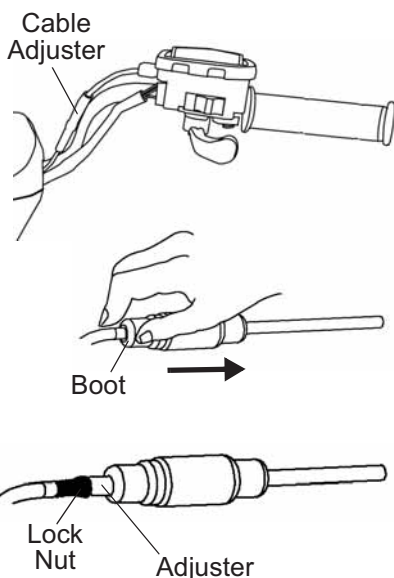

Throttle Cable Freeplay

4. Place the transmission in PARK. Lock the parking brake.
5. Start the engine and allow the idle to stabilize. If necessary, tap the throttle lever to ensure the idle speed settles.
6. If idle speed remains above or below the recommended setting (see specification pages), verify the correct gap. If gap is correct and idle speed is still not satisfactory, please see your POLARIS dealer for service.
7. With the engine running, turn the handlebars fully to the left and right. Tap the throttle lever at each turn, verifying that idle RPM returns to the recommended setting. If idle speed increases, it may be necessary to increase the gap between the stop pin and throttle arm, but do not exceed the recommended 2-3 mm gap.
8. When adjustments are complete, tighten the locknut.
9. Squeeze the end of the rubber boot and slide it over the cable adjuster to its original position.
10. Ensure the control cover seal is in place, then reinstall the cover and screws.

MAINTENANCE

Battery

⚠ WARNING

Improperly connecting or disconnecting battery cables can result in an explosion and cause serious injury or death. When removing the battery, always disconnect the negative (black) cable first. When reinstalling the battery, always connect the negative (black) cable last.

Your ATV is equipped with a sealed battery, which requires little maintenance. POLARIS does not recommend using a conventional battery in this vehicle. The orientation of the battery could result in electrolyte leakage, which would shorten the life of the battery considerably.

Always keep battery terminals and connections free of corrosion. If cleaning is necessary, remove corrosion with a stiff wire brush. Wash with a solution of one tablespoon baking soda and one cup water. Rinse well with tap water and dry off with clean shop towels. Coat the terminals with dielectric grease or petroleum jelly.

Battery Removal

1. Remove the front rack.
2. Disconnect the black (negative) battery cable first.
3. Disconnect the red (positive) battery cable last.
4. Disconnect the battery hold-down strap.
5. Lift the battery out of the ATV.

Battery

Battery Installation

Using a new battery that has not been fully charged can damage the battery and result in a shorter life. It can also hinder vehicle performance. Follow the battery charging instructions on page 110 before installing the battery.

If your factory-installed 18 AH battery cannot maintain a charge because of operation in extreme cold or with multiple electrical accessories, please see your POLARIS dealer to purchase a 30 AH battery. Before installing the 30 AH battery, remove the plastic spacer at the bottom of the battery compartment. Save the spacer for future use.

1. Ensure that the battery is fully charged.
2. Place the battery in the battery holder.
3. Coat the terminals with dielectric grease or petroleum jelly.
4. Secure the battery hold-down strap.
5. Connect and tighten the red (positive) cable first.
6. Connect and tighten the black (negative) cable last.
7. Verify that cables are properly routed. Cables should be safely tucked away at the front and rear of the battery.
8. Install the front rack.

Battery Storage

Whenever the vehicle is not used for a period of three months or more, remove the battery from the vehicle, ensure that it's fully charged, and store it out of the sun in a cool, dry place. Check battery voltage each month during storage and recharge as needed to maintain a full charge.

POLARIS recommends maintaining battery charge by using a POLARIS Battery Tender charger or by charging about once a month to make up for normal self-discharge. Battery Tender can be left connected during the storage period, and will automatically charge the battery if the voltage drops below a pre-determined point. See page 121 for the part numbers of POLARIS products.

MAINTENANCE

Battery

Battery Charging

The following battery charging instructions apply only to the installation of a sealed battery. Read all instructions before proceeding with the installation of this battery.

The sealed battery is already filled with electrolyte and has been sealed and *fully charged* at the factory. *Never* pry the sealing strip off or add any other fluid to this battery.

The single most important thing about maintaining a sealed battery is to keep it fully charged. Since the battery is sealed and the sealing strip cannot be removed, you must use a voltmeter or multimeter to measure DC voltage.

WARNING! An overheated battery may explode, causing severe injury or death. Always watch charging times carefully. Stop charging if the battery becomes very warm to the touch. Allow it to cool before resuming charging.

For a refresh charge, follow all instructions carefully.

1. The battery should be disconnected from a load or charger for at least two hours before checking voltage. Check the battery voltage with a voltmeter or multimeter. A fully charged battery will register 12.8 V or higher.
2. If the voltage is less than 12.8 volts, recharge the battery at 1.2 amps or less until battery voltage is 12.8 or greater.
3. When using an automatic charger, refer to the charger manufacturer's instructions for recharging. When using a constant current charger, use the guidelines on the next page for recharging.

Battery

Battery Charging

Always verify battery condition before and 1-2 hours after the end of charging.

State of Charge	Voltage	Action	Charge Time (Using constant current charger @ standard amps specified on top of battery)
100%	12.8-13.0 volts	None, check at 3 mos. from date of manufacture	None required
75%-100%	12.5-12.8 volts	May need slight charge, if no charge given, check in 3 months	3-6 hours
50%-75%	12.0-12.5 volts	Needs charge	5-11 hours
25%-50%	11.5-12.0 volts	Needs charge	At least 13 hours, verify state of charge
0%-25%	11.5 volts or less	Needs charge with desulfating charger	At least 20 hours

MAINTENANCE

Cleaning and Storage

Washing the Vehicle

Keeping your POLARIS vehicle clean will not only improve its appearance but it can also extend the life of various components.

NOTICE: High water pressure may damage components. POLARIS recommends washing the vehicle by hand or with a garden hose, using mild soap.

Certain products, including insect repellents and chemicals, will damage plastic surfaces. Do not allow these types of products to contact the vehicle.

The best and safest way to clean your POLARIS vehicle is with a garden hose and a pail of mild soap and water.

1. Use a professional-type washing cloth, cleaning the upper body first and the lower parts last.
2. Rinse with clean water frequently.
3. Dry surfaces with a chamois to prevent water spots.

Washing Tips

- Avoid the use of harsh cleaners, which can scratch the finish.
- Do not use a power washer to clean the vehicle.
- Do not use medium to heavy duty compounds on the finish.
- Always use clean cloths and pads for cleaning and polishing. Old or reused cloths and pads may contain dirt particles that will scratch the finish.

Cleaning and Storage

Washing the Vehicle

If a high pressure water system is used for cleaning (not recommended), exercise extreme caution. The water may damage components and could remove paint and labels. Avoid directing the water stream at the following items:

- Wheel bearings
- Radiator
- Transmission seals
- Cab and body panels
- Electrical components
- Switches and controls
- Fuel system components
- Labels and decals

If an informational or graphic label becomes illegible or comes off, contact your POLARIS dealer to purchase a replacement. Replacement *safety* labels are provided by POLARIS at no charge.

Grease all zerk fittings immediately after washing. Allow the engine to run for a while to evaporate any water that may have entered the engine or exhaust system.

Polishing the Vehicle

POLARIS recommends the use of common household aerosol furniture polish for polishing the finish on your POLARIS vehicle. Follow the instructions on the container.

Polishing Tips

- Avoid the use of automotive products, some of which can scratch the finish of your vehicle.
- Always use clean cloths and pads for cleaning and polishing. Old or reused cloths and pads may contain dirt particles that will scratch the finish.

MAINTENANCE

Cleaning and Storage

Storage Tips

NOTICE: Starting the engine during the storage period will disturb the protective film created by fogging and damage could occur. Never start the engine during the storage period.

Clean the Exterior

Make any necessary repairs and then clean the vehicle as recommended. See page 112.

Oil and Filter

Change the oil and filter. See page 78.

Fluid Levels

Inspect the following fluid levels. Change fluids as recommended in the Periodic Maintenance Chart beginning on page 73.

- Demand drive unit (front gearcase)
- Rear gearcase
- Transmission
- Brake fluid (change every two years and any time the fluid looks dark or contaminated)
- Coolant (test strength)

Stabilize the Fuel

1. Fill the fuel tank.
2. Add POLARIS Carbon Clean Fuel Treatment or POLARIS Fuel Stabilizer. Follow the instructions on the container for the recommended amount. Carbon Clean removes water from fuel systems, stabilizes fuel and removes carbon deposits from pistons, rings, valves and exhaust systems.
3. Allow the engine to run for 15-20 minutes to allow the stabilizer to disperse through the entire fuel delivery system.

Cleaning and Storage

Storage Tips

Fog the Engine

1. After stabilizing the fuel, remove the spark plugs and add 2-3 tablespoons of engine oil. To access the plug holes, use a section of clear 1/4" hose and a small plastic squeeze bottle filled with the pre-measured amount of oil.
2. Reinstall the spark plugs. Torque to specification.
3. Apply dielectric grease to the inside of each spark plug cap and reinstall the caps onto the plugs.
4. Turn the engine over several times using electric start. Oil will be forced in and around the piston rings and ring lands, coating the cylinder with a protective film of fresh oil.
5. If POLARIS fuel system additive is not used, the fuel tank, fuel lines, and injectors should be completely drained of gasoline.

Air Filter / Air Box

1. Inspect and clean (or replace) the pre-cleaner and air filter. See page 92.
2. Clean the air box.

Inspect and Lubricate

Inspect all cables and lubricate all areas of the vehicle as recommended in the Periodic Maintenance Chart beginning on page 73.

Battery Maintenance

Remove the battery and recharge it as outlined on page 110. Store the battery in a cool, dry place.

Storage Area/Covers

Set the tire pressure and safely support the ATV with the tires slightly off the ground. Be sure the storage area is well ventilated. Cover the vehicle with a genuine POLARIS cover. Do not use plastic or coated materials. They do not allow enough ventilation to prevent condensation, and may promote corrosion and oxidation.

MAINTENANCE

Transporting the ATV

1. Stop the engine.
2. Place the transmission in PARK.
3. Lock the parking brake.
4. Secure the fuel cap, oil cap and seat.
5. Always tie the frame of the ATV to the transporting unit securely with suitable straps or rope. Do not attach tie straps to the front A-arm bolt pockets, racks or handlebars.
6. Remove the key to prevent loss during transporting.

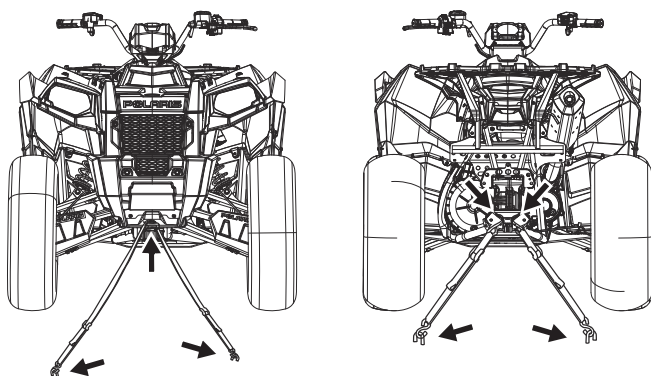

Accessories

Auxiliary power outlets provide 12-volt power for operating accessories. Accessory outlets are available for all models. POLARIS also has a wide range of additional accessories available for your ATV. Always install accessories that are approved for ATV use. Please see your POLARIS dealer.

TROUBLESHOOTING

Drive Belt Wear/Burn

Possible Cause	Solution
Driving onto a pickup or tall trailer in high range	Use low range during loading.
Starting out going up a steep incline	Use low range or turn around using the K-turn (see page 64).
Driving at low RPM or ground speed (3-7 MPH)	Drive at a higher speed or use low range more frequently. See page 102.
Insufficient warm-up at low ambient temperatures	Warm the engine at least 5 minutes. With the transmission in neutral, advance the throttle to about 1/8 throttle in short bursts, 5 to 7 times. The belt will become more flexible and prevent belt burning.
Slow/easy clutch engagement	Use the throttle quickly and effectively.
Towing/pushing at low RPM/low ground speed	Use low range only.
Utility use/plowing	Use low range only.
Stuck in mud or snow	Shift the transmission to low range and carefully use fast, aggressive throttle application to engage clutch. WARNING! Excessive throttle may cause loss of control and vehicle overturn.
Climbing over large objects from a stopped position	Shift the transmission to low range and carefully use fast, brief, aggressive throttle application to engage clutch. WARNING! Excessive throttle may cause loss of control and vehicle overturn.
Belt slippage from water or snow ingestion into the PVT system	Dry out the PVT. See page 102. Inspect clutch seals for damage if repeated leaking occurs.
Clutch malfunction	See your POLARIS dealer.
Poor engine performance	Check for fouled plugs or foreign material in gas tank or fuel lines. See your dealer.
Slippage from failure to warm up belt	Always warm up the belt by operating below 30 mph for one mile (5 miles or more when temperature is below freezing).
Wrong or missing belt	Install the recommended belt.
Improper break-in	Always break in a new belt and/or clutch. See page 53.

TROUBLESHOOTING

Engine Doesn't Turn Over

Possible Cause	Solution
Low battery voltage	Recharge the battery to 12.8 VDC
Loose battery connections	Check all connections and tighten
Loose solenoid connections	Check all connections and tighten

Engine Turns Over, Fails to Start

Possible Cause	Solution
Out of fuel	Refuel, cycle key to ON position three times for 5 seconds each, then start
Clogged fuel filter	See your dealer
Water is present in fuel	Drain the fuel system and refuel
Old or non-recommended fuel	Replace with fresh recommended fuel
Fouled or defective spark plugs	Inspect plugs and replace if necessary
No spark to spark plug	Inspect plugs, verify stop switch is on
Water or fuel in crankcase	Immediately see your POLARIS dealer
Low battery voltage	Recharge the battery to 12.8 VDC
Mechanical failure	See your dealer

Engine Backfires

Possible Cause	Solution
Weak spark from spark plug	Inspect, clean and/or replace spark plugs
Incorrect spark plug gap or heat range	Set gap to specs or replace plugs
Old or non-recommended fuel	Replace with fresh recommended fuel
Incorrectly installed spark plug wires	See your dealer
Incorrect ignition timing	See your dealer
Mechanical failure	See your dealer
Loose ignition connections	Check all connections and tighten
Water present in fuel	Replace with fresh recommended fuel
Leaking exhaust components	See your dealer

TROUBLESHOOTING

Engine Pings or Knocks

Possible Cause	Solution
Poor quality or low octane fuel	Replace with recommended fuel
Incorrect ignition timing	See your dealer
Incorrect spark plug gap or heat range	Set gap to specs or replace plugs

Engine Runs Irregularly, Stalls or Misfires

Possible Cause	Solution
Fouled or defective spark plugs	Inspect, clean and/or replace spark plugs
Worn or defective spark plug wires	See your dealer
Incorrect spark plug gap or heat range	Set gap to specs or replace plugs
Loose ignition connections	Check all connections and tighten
Water present in fuel	Replace with new fuel
Low battery voltage	Recharge battery to 12.8 VDC
Kinked or plugged fuel tank vent line	Inspect and replace
Incorrect fuel	Replace with recommended fuel
Clogged air filter	Inspect and clean or replace
Reverse speed limiter malfunction	See your dealer
Throttle release switch malfunction	See your dealer
Other mechanical failure	See your dealer

Possible Lean Fuel Cause	Solution
Low or contaminated fuel	Add or change fuel, clean the fuel system
Kinked or plugged fuel tank vent line	Inspect and replace
Low octane fuel	Replace with recommended fuel
Clogged fuel filter	See your dealer
Incorrect fuel	Replace with recommended fuel

Possible Rich Fuel Cause	Solution
Fuel is very high octane	Replace with lower octane fuel
Stopping/starting without adequate warm-up	Allow engine to warm up before operating and/or stopping
Incorrect fuel	Replace with recommended fuel
Clogged air filter	Inspect and clean or replace

TROUBLESHOOTING

Engine Stops or Loses Power

Possible Cause	Solution
Out of fuel	Refuel, cycle key to ON position three times for 5 seconds each, then start
Kinked or plugged fuel vent line	Inspect and replace
Water is present in fuel	Replace with new fuel
Fouled or defective spark plugs	Inspect, clean and/or replace spark plug
Worn or defective spark plug wires	See your dealer
Incorrect spark plug gap or heat range	Set gap to specs or replace plug
Loose ignition connections	Check all connections and tighten
Low battery voltage	Recharge the battery to 12.8 VDC
Incorrect fuel	Replace with fresh recommended fuel
Clogged air filter	Inspect and clean or replace
Reverse speed limiter malfunction	See your dealer
Throttle release switch malfunction	See your dealer
Other mechanical failure	See your dealer
Overheated engine	Clean radiator screen and core, clean engine exterior, see your dealer

Engine Overheating

Possible Cause	Solution
Debris lodged in screen	Clean the screen.
Plugged Radiator	Use a garden hose to flush any debris from the radiator fins. NOTE: High pressure washers can deform the radiator fins and reduce cooling efficiency.

POLARIS PRODUCTS

Part Number	Description
Engine Lubricant	
2870791	Fogging Oil (12 oz./355 ml Aerosol)
2876244	PS-4 PLUS Performance Synthetic 2W-50 4-Cycle Oil (qt./.95 l)
2876245	PS-4 PLUS Performance Synthetic 2W-50 4-Cycle Oil (gal./3.8 l)
Gearcase / Transmission Lubricants	
2878068	AGL PLUS Transmission Fluid (qt./.95 l)
2878069	AGL PLUS Transmission Fluid (gal./3.8 l)
2877922	Demand Drive Plus Fluid (qt./.95 l)
2877923	Demand Drive Plus Fluid (gal./3.8 l)
2871653	Premium ATV Angle Drive Fluid (8 oz./237 ml)
2872276	Premium ATV Angle Drive Fluid (2.5 gal./9.5 l)
2870465	Pump for Gallon (3.8 l) Jug
Coolant	
2871323	60/40 Coolant (gal./3.8 l)
2871534	60/40 Coolant (qt./.95 l)
Grease / Specialized Lubricants	
2871312	Grease Gun Kit, Premium All Season
2871322	Premium All Season Grease (3 oz./89 ml cartridge)
2871423	Premium All Season Grease (14 oz./414 ml cartridge)
2871460	Starter Drive Grease
2871515	Premium U-Joint Lube (3 oz./89 ml cartridge)
2871551	Premium U-Joint Lube (14 oz./414 ml cartridge)
2871329	Dielectric Grease (Nyogel™)
Additives / Miscellaneous	
2871326	Carbon Clean Plus
2870652	Fuel Stabilizer
2872189	DOT 4 Brake Fluid
2871956	Loctite™ 565 Thread Sealant
2859044	POLARIS Battery Tender™ Charger

SPECIFICATIONS

SCRAMBLER 850 XP / 850 XP EPS	
Maximum Weight Capacity	290 lbs. (131 kg) (includes operator, cargo and accessories)
Dry Weight	740 lbs. (335.7 kg) (XP) 750 lbs. (340.2 kg) (XP EPS)
Fuel Capacity	5.25 gal. (20 l)
Engine Oil Capacity	2 qts. (1.9 l)
Coolant Capacity	2 qts. (1.9 l)
Rear Gearcase Oil Capacity	7.1 oz. (210 ml)
Demand Drive Fluid Capacity	9.3 oz. (275 ml)
Transmission Oil Capacity	37 oz. (1100 ml)
Front Rack Capacity	25 lbs. (11.3 kg)
Rear Rack Capacity	50 lbs. (22.7 kg)
Receiver Hitch Tongue Capacity	150 lbs. (68 kg)
Hitch Towing Rating	1500 lbs. (680.4 kg)
Unbraked Trailer Towing Capacity*	1914 lbs. (868 kg)
Overall Length	82.5 in. (209.5 cm)
Overall Width	48 in. (122 cm)
Overall Height	49.5 in. (125.7 cm)
Wheelbase	53 in. (134.6 cm)
Ground Clearance	10.6 in. (27 cm)
Minimum Turning Radius	84 in. (213 cm) unloaded
Engine	EHO850LE
Displacement	850 cc
Bore x Stroke	87 x 71.5
Alternator Output	475w @1200 RPM/Peak 630w
Compression Ratio	11:1
Starting System	Electric
Ignition System	Electronic Fuel Injection
Ignition Timing	6° +/- 5° BTDC @ 1200 RPM, Engine warm
Idle RPM	1200 +/- 50
Throttle Body/Size	Mikuni Dual Bore/42 mm
Spark Plug Type / Gap	REA6MCX / .035 in. (0.9 mm)
Lubrication System	Wet Sump
Driving System Type	Automatic PVT (POLARIS Variable Transmission)

* Based on EU Directive 76/432/EC

SPECIFICATIONS

SCRAMBLER 850 XP / 850 XP EPS

Front Suspension	Dual a-arm with 9.2" (23 cm) travel (XP) Dual a-arm with 9.2" (23 cm) travel (XP EPS)
Rear Suspension	Progressive rate with 10.2" (26 cm) travel (XP) Progressive rate with 10.2" (26 cm) travel (XP EPS)
Transmission	H/L/N/R/P
Gear Reduction, Low	5.034:1
Gear Reduction, Reverse	4.508:1
Gear Reduction, High	2.367:1
Drive Ratio, Front	3.818:1
Drive Ratio, Rear	3.7:1
Tires/Pressure, Front	26x8-14 / 7 psi (48.3 kPa)
Tires/Pressure, Rear	26x10-14 / 7 psi (48.3 kPa)
Brakes, Front/Rear	Single-Control Hydraulic Disc, All Wheel
Brakes, Auxiliary	Foot-Activated Hydraulic Disc, Rear Wheel
Brake, Parking	Hydraulic Lock, All Wheel
Headlight	Hi/Lo Beam on Bumper (50 watt)
Taillight/Brake Light	LED
Instrument Cluster	Digital/Analog (XP) Digital LCD/LED (XP EPS)

Clutching

Altitude		Shift Weight	Drive Clutch Spring	Driven Clutch Spring	Helix*
Meters (Feet)	0-1800 (0-6000)	24-63 PN 5632215	Red/White PN 7043349	Red/White PN 3235088	105-165 BA3 PN 3235092
	1800-3700 (6000-12000)	24-60 PN 5632216	Red/White PN 7043349	Red/White PN 3235088	105-165 BA3 PN 3235092

*EBS models require no helix/spring adjustment

WARRANTY

LIMITED WARRANTY

POLARIS Sales Inc., 2100 Highway 55, Medina, MN 55340, gives a SIX MONTH LIMITED WARRANTY on all components of the POLARIS All Terrain Vehicle (ATV) against defects in material or workmanship. Warranty period will vary regionally. This warranty covers the parts and labor charges for repair or replacement of defective parts which are covered by this warranty. This warranty begins on the date of purchase. This warranty is transferable to another consumer during the warranty period through a POLARIS dealer.

REGISTRATION

At the time of sale, the Warranty Registration Form must be completed by your dealer and submitted to POLARIS within ten days. Upon receipt of this registration, POLARIS will record the registration for warranty. No verification of registration will be sent to the purchaser as the copy of the Warranty Registration Form will be the warranty entitlement. If you have not signed the original registration and received the customer copy, please contact your dealer immediately. **NO WARRANTY COVERAGE WILL BE ALLOWED UNLESS YOUR ATV IS REGISTERED WITH POLARIS.**

Initial dealer preparation and set-up of your ATV is very important in ensuring trouble-free operation. Purchasing a machine in the crate or without proper dealer set-up will void your warranty coverage.

WARRANTY

WARRANTY COVERAGE AND EXCLUSIONS: LIMITATIONS OF WARRANTIES AND REMEDIES

The POLARIS limited warranty excludes any failures that are not caused by a defect in material or workmanship. This warranty does not cover accidental damage, normal wear and tear, abuse or improper handling. This warranty also does not cover any ATV that has been altered structurally, modified, neglected, improperly maintained, used for racing, or used for purposes other than for which it was manufactured, or for any damages which occur during trailer transit or as a result of unauthorized service or the use of unauthorized parts. In addition, this warranty does not cover physical damage to paint or finish, stress cracks, tearing or puncturing of upholstery material, corrosion, or defects in parts, components or the ATV due to fire, explosions or any other cause beyond POLARIS' control.

Warranty does not apply to parts exposed to friction surfaces, stresses, environmental conditions and/or contamination for which they were not designed or not intended, including but not limited to the following items:

- Wheels and tires
- Suspension components
- Brake components
- Seat components
- Clutches and components
- Steering components
- Batteries
- Light bulbs/Sealed beam lamps
- Finished and unfinished surfaces
- Carburetor/Throttle body components
- Engine components
- Drive belts
- Hydraulic components
- Circuit breakers/Fuses
- Electronic components

Warranty applies to the product only and does not allow for coverage of personal loss. Some items are considered "consumable," meaning they are considered part of normal maintenance or part of completing an effective repair. The following items are excluded from warranty coverage in the event of a warranty claim:

- Spark Plugs
- Filters
- Fuel
- Sealants
- Hotel fees
- Towing charges
- Mileage
- Rentals/Loss of product use
- Lubricants such as oil, grease, etc.
- Batteries (unless defective)
- Cosmetic damage/repair
- Coolants
- Meals
- Shipping/ handling fees
- Product pick-up/delivery
- Loss of vacation/personal time

WARRANTY

LIMITATIONS OF WARRANTIES AND REMEDIES

This warranty also excludes failures resulting from improper lubrication; improper engine timing; improper fuel; surface imperfections caused by external stress, heat, cold or contamination; operator error or abuse; improper component alignment, tension, adjustment or altitude compensation; failure due to snow, water, dirt or other foreign substance ingestion/contamination; improper maintenance; modified components; use of aftermarket components resulting in failure; unauthorized repairs; repairs made after the warranty period expires or by an unauthorized repair center; use of the product in competition or for commercial purposes. Warranty will not apply to any product which has been damaged by abuse, accident, fire or any other casualty not determined a defect of materials or workmanship.

This warranty does not cover the use of unauthorized lubricants, chemicals, or fuels that are not compatible with the ATV. The exclusive remedy for breach of this warranty shall be, at POLARIS' exclusive option, repair or replacement of any defective materials, or components or products. THE REMEDIES SET FORTH IN THIS WARRANTY ARE THE ONLY REMEDIES AVAILABLE TO ANY PERSON FOR BREACH OF THIS WARRANTY. POLARIS SHALL HAVE NO LIABILITY TO ANY PERSON FOR INCIDENTAL, CONSEQUENTIAL OR SPECIAL DAMAGES OF ANY DESCRIPTION, WHETHER ARISING OUT OF EXPRESS OR IMPLIED WARRANTY OR ANY OTHER CONTRACT, NEGLIGENCE, OR OTHER TORT OR OTHERWISE. THIS EXCLUSION OF CONSEQUENTIAL, INCIDENTAL, AND SPECIAL DAMAGES IS INDEPENDENT FROM AND SHALL SURVIVE ANY FINDING THAT THE EXCLUSIVE REMEDY FAILED OF ITS ESSENTIAL PURPOSE. Some regions do not permit the exclusion or limitation of incidental or consequential damages or implied warranties, so the above limitations or exclusions may not apply to you if inconsistent with controlling regional law.

ALL IMPLIED WARRANTIES (INCLUDING BUT NOT LIMITED TO THE IMPLIED WARRANTIES OF MERCHANTABILITY AND FITNESS FOR A PARTICULAR PURPOSE) ARE LIMITED IN DURATION TO THE ABOVE SIX MONTH WARRANTY PERIOD. POLARIS FURTHER DISCLAIMS ALL EXPRESS WARRANTIES NOT STATED IN THIS WARRANTY. Some regions do not allow limitations on how long an implied warranty lasts, so the above limitation may not apply to you if inconsistent with controlling regional law.

WARRANTY

HOW TO OBTAIN WARRANTY SERVICE

If your ATV requires warranty service, you must take it to a POLARIS dealer authorized to repair POLARIS ATVs. When requesting warranty service you must present your copy of the Warranty Registration form to the dealer. (THE COST OF TRANSPORTATION TO AND FROM THE DEALER IS YOUR RESPONSIBILITY). POLARIS suggests that you use your original selling dealer; however, you may use any POLARIS Servicing Dealer to perform warranty service.

Please work with your dealer to resolve any warranty issues. Should your dealer require any additional assistance they will contact the appropriate person at POLARIS.

This warranty gives you specific legal rights, and you may also have other rights which vary from region to region.

If any of the above terms are void because of regional or federal law, all other warranty terms will remain in effect.

Engine Oil

1. Mixing oil brands or using non-recommended oil may cause engine damage. We recommend the use of POLARIS engine oil for your ATV.
2. Damage resulting from the use of non-recommended lubricants may not be covered by warranty.

SPARK ARRESTER

POLARIS warrants that the spark arrester in this vehicle will meet the efficiency requirements of USFS standard 5100-1c for at least 1000 hours when subjected to normal use and when maintenance and installation are in accordance with POLARIS recommendations.

WARRANTY

Exported Vehicles

EXCEPT WHERE SPECIFICALLY REQUIRED BY LAW, THERE IS NO WARRANTY OR SERVICE BULLETIN COVERAGE ON THIS VEHICLE IF IT IS SOLD OUTSIDE THE COUNTRY OF THE SELLING DEALER'S AUTHORIZED LOCATION.

This policy does not apply to vehicles that have received authorization for export from POLARIS Industries. Dealers may not give authorization for export. You should consult an authorized dealer to determine this vehicle's warranty or service bulletin coverage if you have any questions.

This policy does not apply to vehicles registered to government officials or military personnel on assignment outside the country of the selling dealer's authorized location.

This policy does not apply to Safety Bulletins.

How to Get Service

In the Country where your vehicle was purchased:

Warranty or Service Bulletin repairs must be done by an authorized POLARIS dealer. If you move or are traveling within the country where your vehicle was purchased, Warranty or Service Bulletin repairs may be requested from any authorized POLARIS dealer who sells the same line as your vehicle.

Outside the Country where your vehicle was purchased:

If you are traveling temporarily outside the country where your vehicle was purchased, you should take your vehicle to an authorized POLARIS dealer. You must show the dealer photo identification from the country of the selling dealer's authorized location as proof of residence. Upon residence verification, the servicing dealer will be authorized to perform the warranty repair.

If You Move:

If you move to another country, be sure to contact POLARIS Customer Assistance and the customs department of the destination country before you move. Vehicles importation rules vary considerably from country to country. You may be required to present documentation of your move to POLARIS Industries in order to continue your warranty coverage. You may also be required to obtain documentation from POLARIS Industries in order to register your vehicle in your new country. You should warranty register your vehicle at a local POLARIS dealer in your new country immediately after you move to continue your warranty coverage and to ensure that you receive safety information and notices regarding your vehicle.

Exported Vehicles

How to Get Service

If Purchased From A Private Party:

If you purchase a POLARIS product from a private citizen, to be kept and used outside of the country in which the vehicle was originally purchased, all warranty coverage will be denied. You must nonetheless warranty register your vehicle under your name and address with a local POLARIS dealer in your country to ensure that you receive safety information and notices regarding your vehicle.

Notice

If your vehicle is registered outside of the country where it was purchased, and you have not followed the procedure set out above, your vehicle will no longer be eligible for warranty or service bulletin coverage of any kind, other than *safety* bulletins. (Vehicles registered to Government officials or military personnel on assignment outside of the country where the vehicle was purchased will continue to be covered by the basic warranty.)

For questions call POLARIS Customer Assistance:

United States: 1-888-704-5290

Canada: 1-204-925-7100

WARRANTY

U.S.A. EPA Emissions Limited Warranty

This emissions limited warranty is in addition to the POLARIS standard limited warranty for your vehicle. POLARIS Industries Inc. warrants that at the time it is first purchased, this emissions-certified vehicle is designed, built and equipped so it conforms with applicable U.S. Environmental Protection Agency emission regulations. POLARIS warrants that the vehicle is free from defects in materials and workmanship that would cause it to fail to meet these regulations.

The warranty period for this emissions-certified vehicle starts on the date the vehicle is first purchased and continues for a period of 500 hours of engine operation, 5000 kilometers (3100 miles) of vehicle travel, or 30 calendar months from the date of purchase, whichever comes first.

This emissions limited warranty covers components whose failure increases the vehicle's regulated emissions, and it covers components of systems whose only purpose is to control emissions. Repairing or replacing other components not covered by this warranty is the responsibility of the vehicle owner. This emissions limited warranty does not cover components whose failure does not increase the vehicle's regulated emissions.

For exhaust emissions, emission-related components include any engine parts related to the following systems:

- Air-induction system
- Fuel system
- Ignition system
- Exhaust gas recirculation systems

The following parts are also considered emission-related components for exhaust emissions:

- Aftertreatment devices
- Crankcase ventilation valves
- Sensors
- Electronic control units

The following parts are considered emission-related components for evaporative emissions:

- Fuel Tank
- Fuel Cap
- Fuel Line
- Fuel Line Fittings
- Clamps*
- Pressure Relief Valves*
- Control Valves*
- Control Solenoids*
- Electronic Controls*
- Vacuum Control Diaphragms*
- Control Cables*
- Control Linkages*
- Purge Valves
- Vapor Hoses
- Liquid/Vapor Separator
- Carbon Canister
- Canister Mounting Brackets
- Carburetor Purge Port Connector

*As related to the evaporative emission control system.

WARRANTY

U.S.A. EPA Emissions Limited Warranty

The exclusive remedy for breach of this limited warranty shall be, at the exclusive option of POLARIS, repair or replacement of any defective materials, components or products. THE REMEDIES SET FORTH IN THIS LIMITED WARRANTY ARE THE ONLY REMEDIES AVAILABLE TO ANY PERSON FOR BREACH OF THIS WARRANTY. POLARIS SHALL HAVE NO LIABILITY TO ANY PERSON FOR INCIDENTAL, CONSEQUENTIAL OR SPECIAL DAMAGES OF ANY DESCRIPTION, WHETHER ARISING OUT OF EXPRESS OR IMPLIED WARRANTY OR ANY OTHER CONTRACT, NEGLIGENCE OR OTHER TORT OR OTHERWISE. THIS EXCLUSION OF CONSEQUENTIAL, INCIDENTAL, AND SPECIAL DAMAGES IS INDEPENDENT FROM AND SHALL SURVIVE ANY FINDING THAT THE EXCLUSIVE REMEDY FAILED OF ITS ESSENTIAL PURPOSE.

ALL IMPLIED WARRANTIES (INCLUDING BUT NOT LIMITED TO ANY IMPLIED WARRANTIES OF MERCHANTABILITY AND FITNESS FOR A PARTICULAR PURPOSE) ARE LIMITED IN DURATION TO THE WARRANTY PERIOD DESCRIBED HEREIN. POLARIS DISCLAIMS ALL EXPRESS WARRANTIES NOT STATED IN THIS WARRANTY. Some states do not allow limitations on how long an implied warranty lasts, so the above limitation may not apply if it is inconsistent with the controlling state law.

This limited warranty excludes failures not caused by a defect in material or workmanship. This limited warranty does not cover damage due to accidents, abuse or improper handling, maintenance or use. This limited warranty also does not cover any engine that has been structurally altered, or when the vehicle has been used in racing competition. This limited warranty also does not cover physical damage, corrosion or defects caused by fire, explosions or other similar causes beyond the control of POLARIS.

Owners are responsible for performing the scheduled maintenance identified in the owner's manual. POLARIS may deny warranty claims for failures that have been caused by the owner's or operator's improper maintenance or use, by accidents for which POLARIS has no responsibility, or by acts of God.

Any qualified repair shop or person may maintain, replace, or repair the emission control devices or systems on your vehicle. POLARIS recommends that you contact an authorized POLARIS dealer to perform any service that may be necessary for your vehicle. POLARIS also recommends that you use only Pure POLARIS parts. It is a potential violation of the Clean Air Act if a part supplied by an aftermarket parts manufacturer reduces the effectiveness of the vehicle's emission controls. Tampering with emission controls is prohibited by federal law.

If you have any questions regarding your warranty rights and responsibilities, please contact the POLARIS Warranty Department at 1-888-704-5290.

INDEX

0-9

4X4 Switch 24, 32

A

Access, Front Compartment 51
Accessories 116
Air Filter 92
All Wheel Drive System 3233
Auxiliary Foot Brake 87

B

Battery **108111**
 Charging 110111
 Extreme Use 30 AH 31
 Installation 109
 Removal 108
 Storage 109
Belt Life 25
Boots 9
Brake Fluid, Auxiliary Foot Brake 30
Brake Fluid, Main Brake System 28
Brake Lever 27
Brake, Foot 30, 87
Brake, Hand Lever 87
Brake, Parking 29
Brakelight 95
Brakes 87
Break-In Period 5253

C

Camber Adjustment 104
Cargo 68-70
Caster Adjustment 104
Check Engine Indicator 41
Cleaning and Storage 112-115
Clothing 9
Clutching
 850 XP 123
Cold Weather Operation 57
Consumer Product Safety 7
Coolant Bottle 85
Coolant, Radiator 86
Cooling System 84-86
Crankcase Emission Control 71

D

Demand Drive Fluid 81
Diagnostic Codes, 850 XP EPS 48-50
Display Units, Standard/Metric 38, 45
Drive Belt Wear/Burn 117
Drivetrain Break-In 53
Driving Downhill 63
Driving in Reverse 67
Driving on a Sidehill 62
Driving on Slippery Surfaces 60
Driving Over Obstacles 66
Driving Procedures 58
Driving Through Water 65
Driving Uphill 61

E

Electromagnetic Interference 71
Electronic Power Steering 31
Emissions Limited Warranty 130-131
Engaging 4X4 33
Engine Break-In 53
Engine Fogging 115
Engine Oil 77-79
EPS Warning Indicator 43
Equipment Modifications 9
Error Codes, Engine 41
Etiquette, Trail Riding 56
Exhaust Emission Control System 71
Extreme Use 30 AH Battery 31
Eye Protection 9

F

Fluid

 Brake 28
 Coolant 84-86
 Demand Drive 81
 Engine Oil 77-79
 Rear Gearcase 82-83
 Transmission Oil 80

Fluid Change

 Demand Drive 81
 Engine Oil 78-79
 Rear Gearcase 83
 Transmission 80

INDEX

F

Fluid Level

Demand Drive	81
Engine Oil	77
Rear Gearcase	82
Transmission	80
Foot Brake, Auxiliary	30
Footwell Removal	89
Front Compartment	51
Front Gearcase (Demand Drive)	81
Front Rack/Compartment	51
Fuel Safety	11
Fuel Tank Cap	31
Fuse Replacement	93

G

Gasoline Handling	11
Gauge, Code Definitions	48-50
Gauge, Digital/Analog	34-41
Gauge, MFD (EPS Models)	42-47
Gauge, MFD (XP EPS Models)	46
Gear Selector	25
Gearcase Oil, Rear	82-83
Gloves	9

H

Hand Brake	87
Handlebar Adjustment	103
Hauling Cargo	68-70
Headlight Switch	24
Helmet	8
High Beam Adjustment	94
High Range Use	102

I

Idle RPM Adjustment	106
Immersion	98
Indicator Lamps	35
Instrument Cluster	34-50

K

Key Switch	25
K-Turn	64

L

Lights	94-95
Adjustments	94-95
Headlamp Replacement	95
Inspection	94
Taillight/Brakelight	95
Low Range Use	102
Lower Headlamp Replacement	95
Lubrication Guide	76

M

Maintenance Chart	72-75
Master Cylinder	28
Metric Display	38, 45
Mode Switch	24
Modifications	9

N

Noise Emission Control System	71
-------------------------------	----

O

Oil

Engine	77-79
Rear Gearcase	82-83
Transmission	80
Oil and Filter Change	78-79

Oil Change

Rear Gearcase	83
Transmission	80

Oil Level

Engine	77
Rear Gearcase	82
Transmission	80

Oil Recommendations	77
Operation on Public Lands	71
Override Switch	24

P

Parking Brake	29
Parking on an Incline	63
Periodic Maintenance Chart	72-75
Polaris Product List	121
Polishing the Vehicle	113

INDEX

P

Power Steering.....	31
Power Steering Unit (Cleaning)....	84
Pre-Ride Checklist.....	54
PVT Break-In.....	53
PVT Drying.....	102
PVT System.....	100-102

R

Rack/Compartment, Front.....	51
Reverse Operation.....	67
Reverse Override Switch.....	24
Rider Information Center.....	36-41
Riding Area.....	56
Riding Gear.....	8-9

S

Safe Operation Practices.....	55
Safety Labels.....	20-23
Safety Training.....	7
Safety Warnings.....	10-19
Severe Use.....	72
Shock Compression (XP EPS)....	105
Shock Spring Adjustment (XP)....	104
Side Panel Removal.....	89
Sidehilling.....	62
Signal Words.....	4
Spark Arrester.....	99
Spark Plug Inspection.....	96-97
Spark Plug Recommendations....	96
Spark Plugs.....	96-97
Speedometer.....	34
Starting the Engine.....	57
Steering Assembly.....	84, 88
Storage.....	112-115
Storage Tips.....	114-115

Switches

4X4 Switch.....	24, 32
Engine Stop Switch.....	25
Headlight Switch.....	24
Main Key Switch.....	25
Mode Switch.....	24
Reverse Override Switch.....	24
Stop Switch.....	25

T

Taillight.....	95
Throttle Body Adjustment.....	106
Throttle Cable Freeplay.....	106-107
Throttle Lever.....	26
Tire Tread Depth.....	90
Tires.....	90-91
Wheel Installation.....	91
Wheel Nut Torque.....	91
Wheel Removal.....	90
Toe Alignment.....	88
Towing Capacities.....	70
Towing Loads.....	70
Trail Etiquette.....	56
Training.....	7
Transmission Gear Selector.....	25
Transmission Oil.....	80
Transporting the ATV.....	116
Tread Lightly.....	56
Turning Around on a Hill.....	64
Turning the Vehicle.....	59

V

Vehicle Identification Numbers.....	6
Vehicle Immersion.....	98

W

Warning Symbols.....	4
Washing the Vehicle.....	112-113
Wheel Hub Tightening.....	90
Wheel Installation.....	91
Wheel Nut Torque Specifications...	91
Wheel Removal.....	90