

2013 POLARIS



RANGER[®] **EV**

Owner's Manual
for Maintenance and Safety

⚠ WARNING

Read, understand, and follow all of the instructions and safety precautions in this manual and on all product labels.

Failure to follow the safety precautions could result in serious injury or death.



The text is printed on 100% recycled
with 40% post-consumer waste (PCW).

WARNING

Improper vehicle use can result in **SEVERE INJURY** or **DEATH**.

NEVER Operate:

- If you are under age 16 and without a valid driver's license.
- At speeds too fast for your skills or the conditions.
- After or while using Alcohol or Drugs.
- On hills steeper than 15 degrees $\leq 15^\circ$.
- On public roads. A collision can occur with another vehicle.
- With more than **ONE** passenger, or with passengers under age twelve or who cannot comfortably reach the floor and hand holds.
- On paved surfaces - pavement may seriously affect handling and control.
- With non-Polaris approved accessories - they may seriously affect stability.

ALWAYS:

- Wear your seat belt. Vehicle rollover could cause severe injury or death.
- Wear a helmet, eye protection, gloves, long-sleeve shirt, long pants and over-the-ankle boots.
- Reduce speed and use extra caution when carrying a passenger.
- Avoid sharp turns or turns while applying heavy throttle.
- Operate slowly in reverse - avoid sharp turns or sudden braking.
- Make sure passenger reads and understands all safety labels.
- Watch for branches or other hazards that could enter vehicle.

READ OWNER'S MANUAL.
FOLLOW ALL INSTRUCTIONS AND WARNINGS.



POLARIS®

For your nearest Polaris dealer,
call 1-800-POLARIS
or visit www.polarisindustries.com
Polaris Sales Inc.
2100 Hwy. 55
Medina, MN 55340
Phone 1-888-704-5290
Part No. 9923941 Rev 01
Printed in USA



WELCOME

Thank you for purchasing a POLARIS vehicle, and welcome to our world-wide family of POLARIS enthusiasts. Be sure to visit us online at www.polarisindustries.com for the latest news, new product introductions, upcoming events, career opportunities and more.

Here at POLARIS we proudly produce an exciting line of utility and recreational products.

- Snowmobiles
- All-terrain vehicles (ATVs)
- *RANGER*® utility vehicles
- Victory Motorcycles®
- Low Emission Vehicles (LEVs)

We believe POLARIS sets a standard of excellence for all utility and recreational vehicles manufactured in the world today. Many years of experience have gone into the engineering, design, and development of your POLARIS vehicle, making it the finest machine we've ever produced.

For safe and enjoyable operation of your vehicle, be sure to follow the instructions and recommendations in this owner's manual. Your manual contains instructions for minor maintenance, but information about major repairs is outlined in the POLARIS Service Manual and should be performed only by a Factory Certified Master Service Dealer® (MSD) Technician.

Your POLARIS dealer knows your vehicle best and is interested in your total satisfaction. Be sure to return to your dealership for all of your service needs during, and after, the warranty period.



POLARIS and *RANGER* are registered trademarks of POLARIS Industries Inc.

Copyright 2012 POLARIS Sales Inc. All information contained within this publication is based on the latest product information at the time of publication. Due to constant improvements in the design and quality of production components, some minor discrepancies may result between the actual vehicle and the information presented in this publication. Depictions and/or procedures in this publication are intended for reference use only. No liability can be accepted for omissions or inaccuracies. Any reprinting or reuse of the depictions and/or procedures contained within, whether whole or in part, is expressly prohibited.

The original instructions for this vehicle are in English. Other languages are provided as translations of the original instructions.

Printed in U.S.A.

2013 *RANGER* EV Owner's Manual

P/N 9923941

TABLE OF CONTENTS

| | |
|------------------------------------|-----------|
| Introduction | 4 |
| Safety | 6 |
| Features and Controls | 16 |
| Operation | 29 |
| Maintenance | 40 |
| Specifications | 56 |
| POLARIS Products | 57 |
| Troubleshooting | 58 |
| Warranty | 59 |
| Maintenance Log | 62 |
| Index | 63 |

INTRODUCTION

The *RANGER* is an off-road vehicle. Familiarize yourself with all laws and regulations concerning the operation of this vehicle in your area.

The following signal words and symbols appear throughout this manual and on your vehicle. Your safety is involved when these words and symbols are used. Become familiar with their meanings before reading the manual.



The safety alert symbol indicates a potential personal injury hazard.

DANGER

A DANGER indicates a hazardous situation that, if not avoided, will result in death or serious injury.

WARNING

A WARNING indicates a hazardous situation that, if not avoided, could result in death or serious injury.

CAUTION

A CAUTION indicates a hazardous situation that, if not avoided, could result in minor or moderate injury.

NOTICE

A NOTICE indicates a situation that could result in property damage.



The Prohibition Safety Sign indicates an action NOT to take in order to avoid a hazard.



The Mandatory Action Sign indicates an action that NEEDS to be taken to avoid a hazard.

WARNING

Failure to follow the warnings contained in this manual can result in severe injury or death.

A POLARIS *RANGER* is not a toy and can be hazardous to operate. This vehicle handles differently than other vehicles. A collision or rollover can occur quickly, even during routine maneuvers like turning, or driving on hills or over obstacles, if you fail to take proper precautions.

- Read this owner's manual. Understand all safety warnings, precautions and operating procedures before operating the vehicle. Keep this manual with the vehicle.
- This vehicle is an ADULT VEHICLE ONLY. You MUST be at least age 16 and have a valid driver's license to operate this vehicle.
- No person under the age of 12 may ride as a passenger in this vehicle. Any passenger must be able to comfortably reach the floor and hand holds.
- Never permit a guest to operate this vehicle unless the guest has read this manual and all product labels.
- Always wear a helmet, eye protection, gloves, long-sleeve shirt, long pants and over-the-ankle boots.
- Always keep hands and feet inside the vehicle at all times.

Vehicle Identification Numbers

Record your vehicle's identification numbers and key number in the spaces provided. Remove the spare key and store it in a safe place. A key can be duplicated only by ordering a key blank (using your key number) and mating it with one of your existing keys. The key switch must be replaced if all keys are lost.



Frame VIN

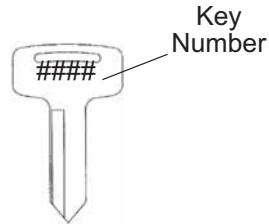

Vehicle Model Number: _____

Frame VIN: _____

Motor Serial Number (on side of motor): _____

Key Number: _____

Equipment Modifications

Never install any accessory that grounds to the vehicle chassis. The chassis is a floating ground to protect against electrical short circuits and hazards.

We strongly recommend that consumers do not install on a POLARIS *RANGER* any equipment that may increase the speed or power of the vehicle, or make any other modifications to the vehicle for these purposes. Any modifications to the original equipment of the vehicle create a substantial safety hazard and increase the risk of bodily injury.

The warranty on your POLARIS *RANGER* is terminated if any equipment has been added to the vehicle, or if any modifications have been made to the vehicle, that increase its speed or power.

The addition of certain accessories, including (but not limited to) mowers, blades, tires, sprayers, or large racks, may change the handling characteristics of the vehicle. Use only POLARIS-approved accessories, and familiarize yourself with their function and effect on the vehicle.

SAFETY

Safety Labels and Locations

Warning labels have been placed on the vehicle for your protection. Read and follow the instructions of the labels on the vehicle carefully. If any of the labels depicted in this manual differ from the labels on your vehicle, always read and follow the instructions of the labels *on the vehicle*.

If any label becomes illegible or comes off, contact your POLARIS dealer to purchase a replacement. Replacement *safety* labels are provided by POLARIS at no charge. The part number is printed on the label.

Passenger/Tire Pressure Warning

WARNING

- Passengers can be thrown off. This can cause serious injury or death.
- Never carry passengers in cargo box.

WARNING

IMPROPER TIRE PRESSURE OR OVERLOADING CAN CAUSE LOSS OF CONTROL RESULTING IN SERIOUS INJURY OR DEATH.

- Reduce speed and allow greater distance for braking when carrying cargo.
- Overloading or carrying tall, off-center, or unsecured loads will increase your risk of losing control. Loads should be centered and carried as low as possible in box.
- For stability on rough or hilly terrain, reduce speed and cargo.
- Be careful if load extends over the side of the box.

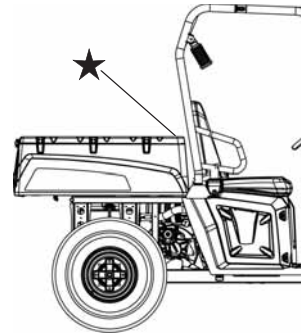

| RANGER | 4x4 | Crew | EV |
|---|-------------------------------|--------------------------------|---------------------------------|
| MAXIMUM CARGO BOX LOAD | 500 lbs. (226 kg) | 500 lbs. (226 kg) | 500 lbs. (226 kg) |
| TIRE PRESSURE IN PSI (KPa) | FRONT 10 (69) REAR 12 (83) | FRONT 14 (97) REAR 16 (110) | FRONT 20 (138) REAR 20 (138) |
| MAXIMUM WEIGHT CAPACITY INCLUDES WEIGHT OF OPERATOR, PASSENGER, CARGO AND ACCESSORIES | 1000 lbs. (454 kg) | 1250 lbs. (547 kg) | 1000 lbs. (454 kg) |
| Read Operation and Maintenance Manual for more detailed loading information. | | | |

7177690

Safety Labels and Locations

Battery Charging Warning

WARNING

- Explosive gases are released when batteries are charged. Keep sparks, flames and cigarettes away. Shield eyes when working near batteries.
- Do not charge batteries in a non-ventilated enclosed area or near flammable materials.
- Do not attempt to charge frozen, leaking, or damaged batteries.
- Connect battery charger to properly rated electrical receptacle with GFCI.
- Do not charge with storage or weather cover on vehicle or with the cab enclosure doors closed, as fire and explosion are possible.
- Refer to Owner's Manual or contact your local POLARIS dealer with any questions.

TO MAXIMIZE BATTERY LIFE

- Always check and maintain water level monthly. Use only distilled water. Water level should be kept 1/4" (6 mm) below fill well. Do not overfill the battery.
- Always keep batteries fully charged. For maximum life, charge your vehicle at every opportunity. Use only the charger supplied with the vehicle. Inspect battery connections regularly.
- Failure to properly maintain your batteries will void warranty coverage.

Battery Charging
Warning



7176414

Battery Compartment Warning

WARNING

- SULFURIC ACID in batteries will burn skin, eyes, and clothing. Do not tip batteries. Keep vent caps tight and level. In event of injury, flush with water and call physician immediately.
- HIGH VOLTAGE CABLES and terminals are contained within this compartment. Improper contact between battery terminals can result in electrical shorts. ELECTRICAL SHORTS can result in burns.
- Do not use high pressure water to wash the battery compartment. Damage to the vented batteries will result.
- Tampering with or unauthorized modification of this unit could result in serious personal injury, will void the warranty, and can result in permanent damage to the vehicle.
- Refer to your Owner's Manual or contact your local POLARIS dealer with any questions.

7176206



Battery Compartment
Warning

SAFETY

Safety Labels and Locations

Battery Caution

CAUTION

- Do not drive through water above the floor of the vehicle. Battery damage will occur.
- Batteries require regular maintenance.
- Failure to maintain batteries in accordance with the owners manual can result in battery damage, vehicle malfunction, fire and/or severe injury or death.
- Max towing speed 10 MPH (16 km/h) - drivetrain damage will occur if towed faster than 10 MPH (16 km/h).
- Set parking brake before leaving vehicle.
- Turn Power On key to "Off" position and remove when not in use.
- When towing vehicle, turn Power On key to "Off" position.

7176204

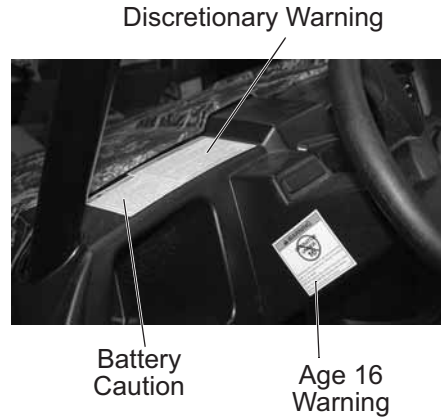

Age 16 Warning

Operating this vehicle if you are under the age of 16 increases your chance of severe injury or death. NEVER operate this vehicle if you are under age 16 and NEVER operate this vehicle without a valid driver's license.

7175566

Discretionary Warning

WARNING

Improper vehicle use can result in Severe Injury or Death.

NEVER Operate:

- At speeds too fast for your skills or the conditions.
- After or while using Alcohol or Drugs.
- On hills steeper than 15 degrees \angle 15°.
- On public roads, a collision can occur with a another vehicle.
- With more than one passenger, or a passenger under age twelve or who cannot comfortably reach the floor and hand holds.
- On paved surfaces - pavement may seriously affect handling and control.
- With non-POLARIS approved accessories - they may seriously affect stability.

ALWAYS:

- Wear your seat belt. Vehicle rollover could cause severe injury or death.
- Wear a helmet and eye protection and keep hands and feet in vehicle at all times.
- Reduce speed and use extra caution when carrying a passenger.
- Avoid sharp turns or turns while applying heavy throttle.
- Operate slowly in reverse - avoid sharp turns or sudden braking.
- Make sure passenger reads and understands all safety labels.
- Watch for branches or other hazards that could enter vehicle.

LOCATE AND READ OWNER'S MANUAL. FOLLOW ALL INSTRUCTIONS AND WARNINGS.

7176169

Safe Riding Gear

Always wear appropriate clothing when riding a POLARIS vehicle. Wear protective clothing for comfort and to reduce the chance of injury.

Helmet

Wearing a helmet can prevent a severe head injury. Whenever riding this POLARIS vehicle, always wear a helmet that meets or exceeds established safety standards.

Approved helmets in the USA and Canada bear a U.S. Department of Transportation (DOT) label.

Approved helmets in Europe, Asia and Oceania bear the ECE 22.05 label. The ECE mark consists of a circle surrounding the letter E, followed by the distinguishing number of the country which has granted approval. The approval number and serial number will also be displayed on the label.

Eye Protection

Do not depend on eyeglasses or sunglasses for eye protection. Whenever riding a POLARIS vehicle, always wear shatterproof goggles or use a shatterproof helmet face shield. POLARIS recommends wearing approved Personal Protective Equipment (PPE) bearing markings such as VESC 8, V-8, Z87.1, or CE. Make sure protective eye wear is kept clean.

Gloves

Wear gloves for comfort and for protection from sun, cold weather and other elements.

Boots

Wear sturdy over-the-ankle boots. Do not ride a POLARIS vehicle with bare feet.

Clothing

Wear long sleeves and long pants to protect arms and legs.

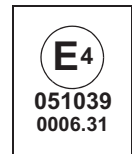

SAFETY

Operator Safety

⚠ WARNING

Serious injury or death can result if you do not follow these instructions and procedures, which are outlined in further detail within your owner's manual.

- Read this manual and all labels carefully. Follow the operating procedures described.
- Never allow anyone under age 16 to operate this vehicle and never allow anyone without a valid driver's license to operate this vehicle.
- Do not carry a passenger until you have at least two hours of driving experience with this vehicle.
- No person under the age of 12 may ride as a passenger in this vehicle. Any passenger must be able to comfortably reach the floor and hand holds.
- The driver and all passengers must wear helmet, eye protection, gloves, long-sleeve shirt, long pants, over-the-ankle boots and seat belt at all times.
- Always keep both hands on the steering wheel and both feet on the floorboards of the vehicle during operation.
- Never permit a guest to operate this vehicle unless the guest has read this manual and all product labels.
- To reduce tipover risk, be especially careful when encountering obstacles and slopes and when braking on hills or during turns.
- This vehicle is for off-road use only. Never operate on public roads. Always avoid paved surfaces.
- Never consume alcohol or drugs before or while operating this vehicle.
- Never operate at excessive speeds. Always travel at a speed proper for the terrain, visibility and operating conditions, and your experience.
- Never attempt jumps or other stunts.
- Always inspect your vehicle each time you use it to make sure it's in safe operating condition. Always follow the inspection and maintenance procedures and schedules described in this manual.
- Always travel slowly and use extra caution when operating on unfamiliar terrain. Be alert to changing terrain.
- Never operate on excessively rough, slippery or loose terrain.
- Always follow proper procedures for turning. Practice turning at slow speeds before attempting to turn at faster speeds. Never turn at excessive speeds.
- Always have this vehicle checked by an authorized POLARIS dealer if it has been involved in an accident.
- Never operate this vehicle on hills too steep for the vehicle or for your abilities. Practice on smaller hills before attempting larger hills.
- Always follow proper procedures for climbing hills as described in this manual. Check the terrain carefully before attempting to climb a hill. Never climb hills with excessively slippery or loose surfaces. Never go over the top of a hill at high speed.

Operator Safety

- Always follow the proper procedures outlined in this manual for traveling downhill and for braking on hills. Check the terrain carefully before descending a hill. Never travel downhill at high speed. Avoid going downhill at an angle, which would cause the vehicle to lean sharply to one side. Travel straight down the hill where possible.
- Always check for obstacles before operating in a new area. Never attempt to operate over large obstacles such as rocks or fallen trees. Always follow the proper procedures outlined in this manual when operating over obstacles.
- Always be careful of skidding or sliding. On slippery surfaces such as ice, travel slowly and exercise caution to reduce the chance of skidding or sliding out of control.
- Never operate your vehicle in fast-flowing water or in water deeper than that specified in this manual. Wet brakes may have reduced stopping ability. Test your brakes after leaving water. If necessary, apply them lightly several times to let friction dry out the pads.
- Always be sure there are no obstacles or people behind your vehicle when operating in reverse. When it's safe to proceed in reverse, move slowly. Avoid turning at sharp angles in reverse.
- Always use the proper size and type of tires specified in this manual. Always maintain proper tire pressure as specified on safety labels.
- Never modify this vehicle through improper installation or use of accessories.
- Never exceed the stated load capacity for this vehicle. Cargo should be properly distributed and securely attached. Reduce speed and follow the instructions in this manual for hauling cargo or pulling a trailer. Allow a greater distance for braking.
- Always set the park brake and remove the key when leaving the vehicle unattended.

European Vibration and Noise

The driver-perceived noise and hand/arm and whole body vibration levels of this machinery is measured per prEN 15997.

The operating conditions of the machinery during testing:

The vehicles were in like-new condition. The environment was controlled as indicated by the test procedure(s).

The uncertainty of vibration exposure measurement is dependent on many factors, including:

- Instrument and calibration uncertainty
- Variations in the machine such as wear of components
- Variation of machine operators such as experience or physique
- Ability of the worker to reproduce typical work during measurements
- Environmental factors such as ambient noise or temperature

SAFETY

Operator Safety

⚠ WARNING

Failure to operate the *RANGER* properly can result in a collision, loss of control, accident or overturn, which may result in serious injury or death. Heed all safety warnings outlined in this section of the owner's manual. See the OPERATION section of the owner's manual for proper operating procedures.

Age Restrictions

This vehicle is an ADULT VEHICLE ONLY. NEVER operate this vehicle if you are under age 16 and NEVER operate without a valid driver's license.

No person under the age of 12 may ride as a passenger in this vehicle. Any passenger must be able to comfortably reach the floor and hand holds.



Operating Without Instruction

Operating this vehicle without proper instruction increases the risk of an accident. The operator must understand how to operate the vehicle properly in different situations and on different types of terrain.

All operators must read and understand the Owner's Manual and all warning and instruction labels before operating the vehicle.

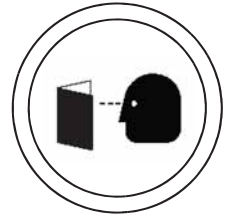

Seat Belts

Riding in this vehicle without wearing the seat belt increases the risk of serious injury in the event of an accident or sudden stop. Riders *must* wear seat belts at all times. Always make sure the seat belts are secured for both the operator and passenger before riding.

Protective Apparel

Riding in this vehicle without wearing an approved helmet and protective eyewear increases the risk of a serious injuries in the event of an accident.

Operator and passenger must always wear an approved helmet that fits properly and eye protection (goggles or face shield).

Ventilation When Charging Batteries

Failure to provide adequate ventilation while charging batteries can result in an explosion. Volatile hydrogen gas is emitted during charging and may accumulate in pockets at the ceiling.

- Always ensure a minimum of 5 air changes per hour in the charging area.
- Always remove any storage covers from the vehicle and open any cab doors (if equipped) before charging.

Failure to Inspect Before Operating

Failure to inspect and verify that the vehicle is in safe operating condition before operating increases the risk of an accident.

Always inspect your *RANGER* before each use to make sure it's in safe operating condition. Always follow all inspection and maintenance procedures and schedules described in the owner's manual.

Operator Safety

Operating With a Load on the Vehicle

The weight of both cargo and passengers impacts vehicle operation. For your safety and the safety of others, carefully consider how your vehicle is loaded and how to safely operate the vehicle. Follow the instructions in this manual for loading, tire pressure, gear selection and speed.

- **Do not exceed vehicle weight capacities.** The vehicle's maximum weight capacity is listed in the specifications section of this manual and on a label on the vehicle. When more passenger weight is added, cargo weight may need to be reduced accordingly.
- The recommended tire pressures are listed in the specifications section of this manual and on a label on the vehicle.

Always follow these guidelines:

| Under ANY of these conditions: | Do ALL of these steps: |
|---|---|
| Passenger and/or cargo exceeds half the maximum weight capacity | <ol style="list-style-type: none"> 1. Slow down. 2. Verify tire pressure. 3. Use extra caution when operating. |
| Operating in rough terrain | |
| Operating over obstacles | |
| Climbing an incline | |
| Towing | |

Using Alcohol or Drugs

Operating the vehicle after consuming alcohol or drugs could adversely affect operator judgment, reaction time, balance and perception.

Never drink alcohol or use drugs or medications before or while operating this vehicle.



Operating a Damaged Vehicle

Operating a damaged vehicle can result in an accident. After any overturn or accident, have a qualified service dealer inspect the entire machine for possible damage, including (but not limited to) brakes, accelerator, steering system and electrical system.

Operating at Excessive Speeds

Operating this vehicle at excessive speeds increases the operator's risk of losing control. Always operate at a speed that's appropriate for the terrain, the visibility and operating conditions, your skills and your passenger's skills.

Operating on Pavement

This vehicle's tires are designed for off-road use only, not for use on pavement. Operating this vehicle on paved surfaces (including sidewalks, paths, parking lots and driveways) may adversely affect the handling of the vehicle and could result in loss of control and accident or overturn.

Avoid operating the vehicle on pavement. If it's unavoidable, travel slowly and avoid sudden turns or stops.

SAFETY

Operator Safety

Operating on Public Roads

Operating this vehicle on public streets, roads or highways could result in a collision with another vehicle.

Never operate this vehicle on any public street, road or highway, including dirt and gravel roads. In some areas it's unlawful to operate this vehicle on public streets, roads and highways.

Turning Improperly

Turning improperly could cause loss of traction, loss of control, accident or overturn. Always follow proper procedures for turning. Never turn abruptly or at sharp angles. Never turn at high speeds. Practice turning at slow speeds before attempting to turn at faster speeds.

Jumps and Stunts

Attempting wheelies, jumps and other stunts increases the risk of an accident or overturn. Never attempt wheelies, jumps, or other stunts. Avoid exhibition driving.

Operating in Unfamiliar Terrain

Failure to use extra caution when operating on unfamiliar terrain could result in an accident or overturn. Unfamiliar terrain may contain hidden rocks, bumps, or holes that could cause loss of control or overturn.

Travel slowly and use extra caution when operating on unfamiliar terrain. Always be alert to changing terrain conditions.

Operating on Slippery Terrain

Failure to use extra caution when operating on excessively rough, slippery or loose terrain could cause loss of traction, loss of control, accident or overturn.

Do not operate on excessively slippery surfaces. Always reduce speed and use additional caution when operating on slippery surfaces.

Stalling While Climbing a Hill

Stalling or rolling backwards while climbing a hill could cause an overturn. Always maintain a steady speed when climbing a hill.

If all forward speed is lost:

- Apply the brakes.
- Switch to reverse and slowly allow the vehicle to roll straight downhill while applying light brake pressure to control speed.

If you begin rolling downhill:

- Never press the accelerator.
- Apply the brakes gradually until the vehicle is fully stopped.
- Switch to reverse and slowly allow the vehicle to roll straight downhill while applying light brake pressure to control speed.

Improper Hill Climbing

Climbing hills improperly can cause loss of control or vehicle overturn. Always follow proper procedures for climbing hills as described in the owner's manual. See page 32..

Operator Safety

Descending Hills Improperly

Improperly descending a hill could cause loss of control or overturn. Always follow proper procedures for traveling down hills as described in the owner's manual.

- Use the brake pedal to control speed when descending a hill. Never travel down a hill at high speed.
- Always descend a hill with the direction selector on FORWARD. Never descend a hill in neutral.
- Always check the terrain carefully before descending a hill.
- Avoid traveling down a hill at an angle, which would cause the vehicle to lean sharply to one side. Travel straight downhill.

Improper Tire Maintenance

Operating this vehicle with improper tires or with improper or uneven tire pressure could cause loss of control or accident.

Always use the size and type of tires specified for your vehicle. Always maintain proper tire pressure as described in the owner's manual and on safety labels.

Operating on Frozen Bodies of Water

Severe injury or death can result if the vehicle and/or the operator fall through the ice. Never operate the vehicle on a frozen body of water unless you have first verified that the ice is sufficiently thick to support the weight and moving force of the vehicle, you and your passengers, and your cargo, together with any other vehicles in your party. Always check with local authorities and residents to confirm ice conditions and thickness over your entire route. Vehicle operators assume all risk associated with ice conditions on frozen bodies of water.

Unauthorized Use of the Vehicle

Leaving the keys in the vehicle can lead to unauthorized use of the vehicle, which could result in an accident or overturn. Always remove the key when the vehicle is not in use.

Hot Drive Systems

The motor and controller are very hot during and after use of the vehicle. Hot components can cause burns and fire. Do not touch hot drive system components. Always keep combustible materials away from the drive system.

Precautions During Maintenance

WARNING! Do not work in or near the battery compartment or on any other electrical component of the vehicle while charging the batteries. Always disconnect the main power connector before servicing or unplugging any electrical components. See page 26.

Always follow all safety instructions in the maintenance portion of this owner's manual, as well as the following:

- Make sure the vehicle is properly immobilized before beginning any maintenance.
- Always block the chassis securely before working under the vehicle.
- Turn the key off and remove it from the vehicle.
- Insulate any tools used within the battery area to prevent sparks or battery explosion caused by shorting the battery terminals or wiring. Remove the batteries, or cover the exposed terminals with an insulating material.

**FOR MORE INFORMATION ABOUT SAFETY
call POLARIS at 1-800-342-3764.**

FEATURES AND CONTROLS

Component Locations

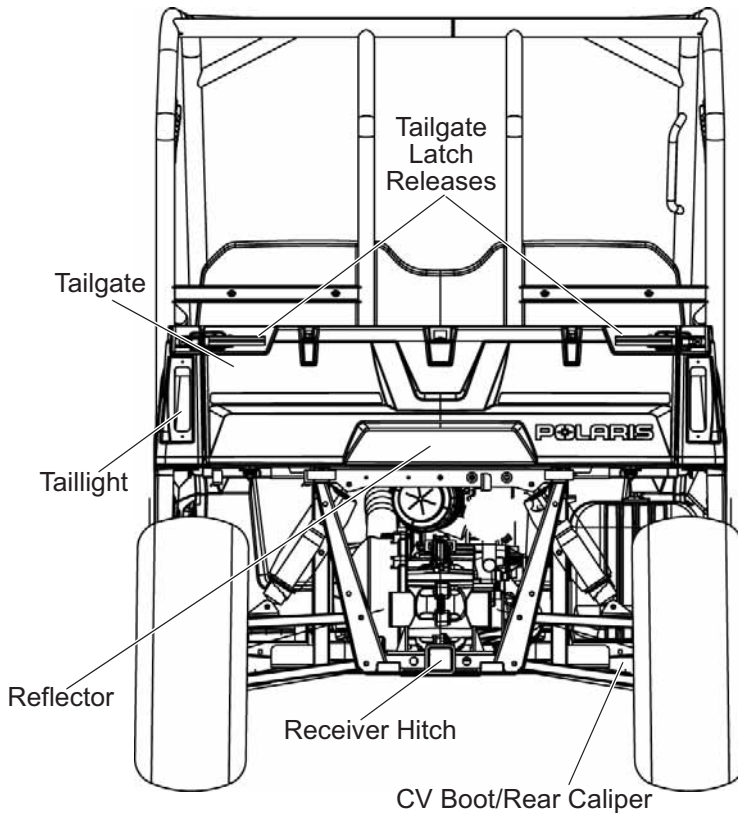
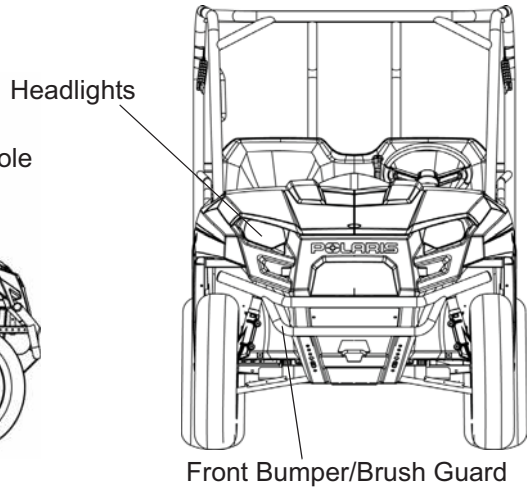
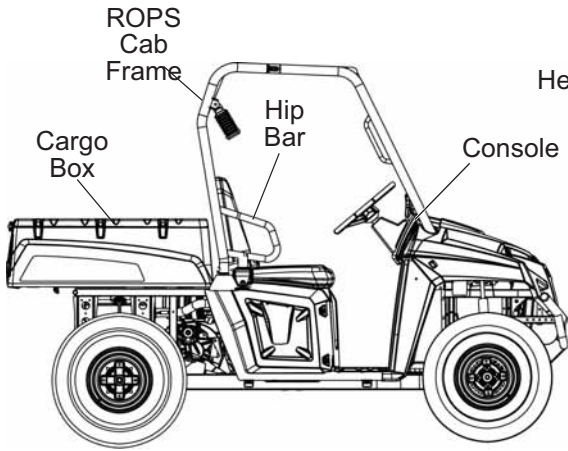

FEATURES AND CONTROLS

Console

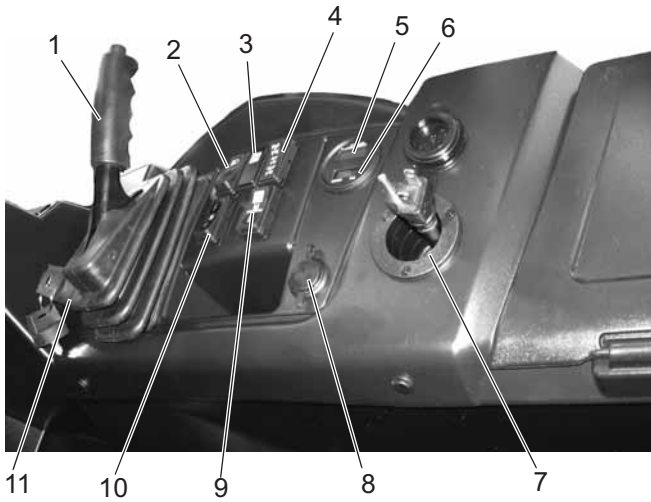

1. Park Brake Lever
2. Headlight Switch
3. Charge Status Indicator
4. AWD Switch
5. Battery Discharge Indicator
6. Hour Meter
7. Charge Plug Holder
8. 12V Auxiliary Outlet
9. Drive Mode Switch
10. Direction Selector
11. Key Switch
12. Indicator Lights

FEATURES AND CONTROLS

Console

Battery Discharge Indicator

The battery discharge indicator displays the amount of charge *removed (used) from fully charged batteries*. When the batteries are fully charged, the right-most bar illuminates, indicating 0% has been used. The charge status indicator will be solid green (see page 19). As the batteries discharge, the bar moves leftward.

Tip: If batteries are not allowed to recharge fully (solid green light), the battery discharge indicator may be inaccurate.

When the second bar from the left flashes, battery discharge is at 70%. The batteries should be recharged as soon as possible. *Avoid discharging the batteries more than 80%.*

NOTICE: If the two left-most bars begin to flash, battery damage may occur with continued operation. Stop the vehicle and recharge the batteries.

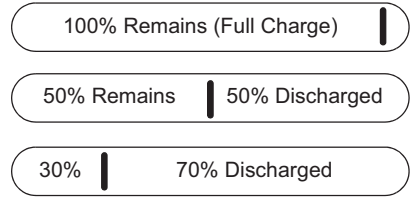

Recharge the batteries

Hour Meter

The hour meter records and displays the hours of actual vehicle movement since manufacture.

Auxiliary 12-Volt Terminal Board

The 12-volt terminal board is located under the hood. It contains constant 12-volt, switched 12-volt and ground terminals that can be used to power auxiliary lights and accessories. The terminals are limited to 10 amps.

Auxiliary Outlets

The 12-volt receptacle can be used to power accessories, but is limited to 10 amps (the terminal board and 12-volt outlet are fused together at 10 amps).

Charging Cord

The charging cord is located inside the charge plug holder on the console. See page 50 for charging instructions.



Charging Cord

FEATURES AND CONTROLS

Console

Park Brake Lever

To help prevent the vehicle from rolling, set the park brake when parking the vehicle. When the park brake is set and the park brake indicator is illuminated, motor speed is limited. If the accelerator is applied, this limiting feature prevents operation, which protects the park brake pads from excessive wear.

Tip: This feature will not operate properly if the park brake connector or switch (under the hood) malfunctions or becomes disconnected, or if the switch has moved. Check for disconnection, then see your dealer promptly if this feature fails to operate properly.

Always apply the service brakes before engaging or releasing the park brake.

1. Apply the brakes.
2. Pull the park brake lever downward as far as possible.
3. To release the park brake, apply the brakes. Press the park brake release inward and move the lever upward as far as possible.

Charge Status Indicator

When charging the batteries, the charge status indicator light flashes and changes color to indicate the status of the charge. Refer to the table below.

| Color | Indication | Code Definition |
|-------|------------|---|
| Green | Solid | Charge is complete, charger is in maintenance mode. |
| Green | Fast Flash | Less than 80% of charge is completed. |
| Green | Slow Flash | More than 80% of charge is completed. |
| Amber | Flashing | Power mode is reduced, low AC voltage or high internal charger temperature exists; open hood to improve air flow. |
| Red | Flashing | Charger error exists; reset charger power and refer to Troubleshooting Guide on page 23. |

Key Switch

Move the direction selector switch to neutral, then turn the key to the ON position to activate the electrical circuits.

Tip: The accelerator will not start the motor if the direction selector switch is in forward or reverse when the key is turned on. Switch to neutral, then choose forward or reverse.

Turn the key to the OFF position to disable all electrical circuits. The key can be removed from the switch when it is in the OFF position.

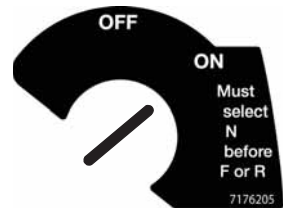

FEATURES AND CONTROLS

Console

Drive Mode Switch

CAUTION! Changing the drive mode switch position while driving could result in an automatic increase or decrease in speed without a change to accelerator pedal pressure.

Press the top of the switch to select high mode. Use high mode for most trail-riding conditions. The vehicle will operate at speeds up to 25 MPH (40 km/h).

Press the bottom of the switch to select low mode. Low mode is recommended for short-term operation in extreme load conditions. Use low mode when towing, hauling loads or maneuvering over obstacles. Speed will be limited to a maximum of 10 MPH (16 km/h) and regenerative braking increases to improve control in aggressive terrain. Return the mode switch to high mode for normal operation.

Move the switch to the center position to select the maximum range mode. Use this mode to operate the vehicle a greater distance or for a longer time period. This mode limits both speed and torque to obtain the maximum driving range.

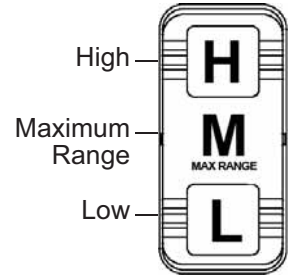

| Mode | Maximum Speed | Torque (percent of maximum torque) | Deceleration (regenerative braking) | Application |
|-----------|------------------|------------------------------------|-------------------------------------|---|
| High | 25 MPH (40 km/h) | 70% | Minimum | Trail riding |
| Max Range | 15 MPH (24 km/h) | 50% | Minimum | Whenever possible, to maximum driving range of battery pack |
| Low | 10 MPH (16 km/h) | 100% | Maximum | Towing, hauling loads, driving on steep hills or aggressive terrain |

FEATURES AND CONTROLS

Console

Direction Selector Switch

When the direction selector is in the center position, the vehicle is in neutral. The vehicle will not move if the accelerator is depressed. Place the switch in neutral before turning the key on.

Push the top of the switch to choose forward operation. Push the bottom of the switch to choose reverse operation.

Always come to a complete stop before reversing direction.

Tip: The malfunction light will illuminate after reversing direction if you press the accelerator pedal before coming to a complete stop.

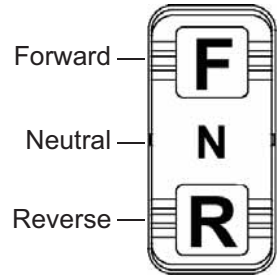

AWD Switch

The AWD switch has three positions: All Wheel Drive (AWD), Differential Lock/Two Wheel Drive (2WD) and Off (1WD/Turf Mode).

Press the top of the switch to engage All Wheel Drive (AWD). See page 39 for operating instructions.

Move the switch to the center position to lock the differential and operate in two wheel drive (2WD).

Press the bottom of the switch to unlock the differential and allow the rear drive wheels to operate independently (1WD). This mode of operation is well suited to turf driving or when active traction is not needed.

See page 39 for Differential Lock operating instructions.

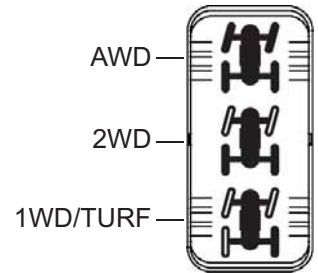

Headlight Switch

Press the top of the switch to turn the headlights on. Press the bottom of the switch to turn the headlights off.

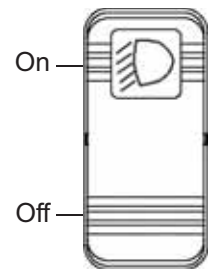

FEATURES AND CONTROLS

Console

Indicator Panel Lights

The indicator lights activate when the key is in the ON position.

Indicator Panel



| Indicator | Status | Indicates |
|-----------------------------------|---|--|
| Malfunction | Steady | Electrical malfunction (flash sequence on controller indicates type; see troubleshooting guide on page 23) |
| | | Key was turned on in forward or reverse (switch to neutral, then to forward or reverse) |
| Park Brake | Steady | Engaged park brake |
| Gear Position | Steady | Selected gear (forward/neutral/reverse) |
| Motor/Controller High Temperature | Flashing | Reduced performance due to elevated temperature |
| | Steady | Power delivery terminated to protect against overheating |
| | <i>If either occurs, stop the vehicle and turn the key off. Allow the motor and controller to cool adequately before operating.</i> | |

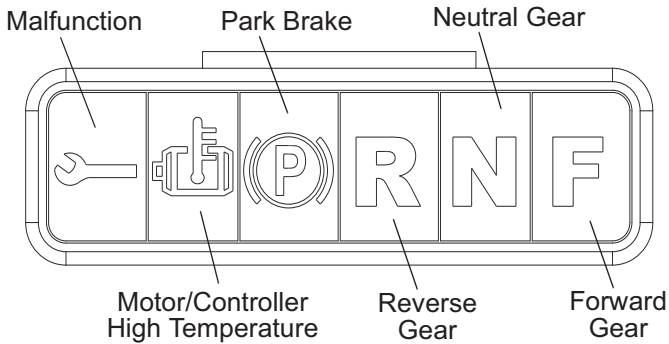

FEATURES AND CONTROLS

Malfunction Indicator Troubleshooting Guide

The malfunction codes will blink on the controller. The code definitions provided here are for informational purposes only.

Tip: If the indicator illuminates due to a minor issue such as a low voltage condition or a sequence fault (reversing direction without releasing the accelerator, turning the key on while in forward or reverse), select neutral and turn the key off and on to clear the error. If the error does not clear, please see your POLARIS dealer for diagnosis and repair.

| # of Blinks | Code Definition |
|-------------|---|
| Steady | Key was turned on in forward or reverse (switch to neutral, then to forward or reverse) |
| 1 | Data or configuration error |
| 2 | Sequence fault |
| 3 | Power fault |
| 4 | Contactors issue |
| 6 | Throttle input error |
| 7 | Voltage protection |
| 8 | Controller or motor out of temperature range |
| 13 | Software fault |

Charge Status Indicator Troubleshooting Guide

The code definitions provided are for informational purposes only. Please see your POLARIS dealer for diagnosis and repair.

| # of Blinks | Code Definition | Solution |
|-------------|--|--|
| 1 | Battery high voltage | Check battery size and condition; reset charger (interrupt AC power for 15 seconds) |
| 2 | Battery low voltage | |
| 3 | Charge time-out, battery pack not reaching required voltage, charger output reduced due to high temperatures | Check connections; operate charger at lower ambient temperature |
| 4 | Battery could not be trickle-charged to minimum voltage | Check battery for shorted or damaged cells |
| 5 | Charger shut down due to overheating | Ensure sufficient cooling air flow (open the hood) and reset the charger (interrupt AC power for 15 seconds) |
| 6 | Charger internal fault | Reset charger (interrupt AC power for 15 seconds); return to qualified service provider if fault persists |

FEATURES AND CONTROLS

Batteries

This vehicle is equipped with eight 12-volt batteries that supply the power needed to operate the vehicle. The batteries are located under the seat. See page 51 for battery access instructions.

Always observe all battery safety warnings and safe handling procedures as outlined on vehicle safety labels and in this manual. Refer to the battery maintenance section beginning on page 49.

Battery Handling Precautions

- Always make sure that all electrical accessories are grounded directly to the negative (-) post on the terminal board. Never use the chassis or body as a ground connection.
- Always keep battery terminals and connections clean and free of corrosion at all times. See page 51.
- Always maintain a full charge on the batteries. For best battery life, avoid discharging the batteries more than 80%. See page 18.
- Make sure new batteries are fully charged before using.
- New deep cycle batteries need to be cycled several times before reaching full capacity (50-125 cycles, depending on type). Capacity will be limited during this time.
- Make sure vent caps are installed properly and securely during vehicle operation and battery charging.
- Recharge batteries fully at the end of each day the vehicle is operated, allowing adequate time for the charger to complete its charge cycle. The batteries in this vehicle do not have a “memory effect”. Frequent charging will extend their life.
- Avoid charging at temperatures above 120° F. (49° C.) ambient air temperature. Closed, unvented storage buildings often exceed this temperature when exposed to direct sunlight.
- Never connect an auxiliary battery to the factory-installed DC-to-DC converter. If more than 10 amps are needed for accessories, always install the POLARIS-approved auxiliary accessory battery kit.
- Never connect a 12-volt accessory directly to the batteries. Always connect any powered accessory to a 12-volt auxiliary outlet or terminal board. See page 18.
- Never connect jumper cables to any of the batteries of this vehicle.
- Use only insulated tools when working in the battery compartment.

FEATURES AND CONTROLS

Batteries

Battery Conditioning

New batteries cannot initially hold all of their capacity. The approximate capacity of the battery pack increases as the number of charge cycles increases.

| | | | | |
|----------------------------------|-----|-----|-----|------|
| # of Charge Cycles: | New | 15 | 30 | 45 |
| Percent of Full Capacity: | 80% | 90% | 95% | 100% |

Ambient Temperature Implications on Batteries

1. Battery range decreases as ambient temperature decreases. This can affect the range by up to 30%.
2. Batteries discharge when left uncharged. They can discharge up to 13% per month (higher rates in warmer climates) with the key off and much faster if the key is left on.
3. Batteries can freeze if left uncharged at low ambient temperatures.

| | | | |
|------------------------------------|--------------------|------------------|------------------|
| Percent Charged: | 100% | 50% | 0% |
| Approximate Freezing Point: | -60° F (-51° C) | 0° F (-18° C) | 25° F (-4° C) |

Charger Operation

Open the hood and any door enclosures or zippers. This will decrease charger temperature, which allows it to operate more efficiently, and shorten charge times. See pages 49-50 for charging procedures.

1. Always use extension cords with the appropriate ratings for the country in which it is used. In North America this is a UL rating. The cords must also be rated for the conditions in which they are used, such as being rated for protection from oil in a garage or workshop environment.
2. Use the proper cord wire gauges for the cord length used:

| | | | |
|----------------|-----------------------------|-----------------------------|-----------------------------|
| Length: | <25 ft (7.5 m) | <50 ft (15 m) | <100 ft (30 m) |
| Gauge: | 16AWG (1.5mm ²) | 14AWG (2.5mm ²) | 10AWG (6.0mm ²) |

Battery Operation Range

Range is significantly affected by tire pressure, alignment, terrain and driving style. Always maintain proper tire pressure as specified on safety labels.

FEATURES AND CONTROLS

Main Power Connector

NOTICE: Damage to electrical connections and components will occur if they are unplugged before the main power connector is disconnected. Always disconnect the main power connector before servicing or unplugging any electrical components.

When disconnected, the main power connector disconnects the battery pack from all electrical components, with the exception of the contactor. After servicing the vehicle, the main power connector should be the last connection to be made.

The main power connector is located under the seat on the driver's side of the controller tray, adjacent to the main line contactor. To disconnect, unplug the connector.

To disconnect the battery pack from the vehicle completely, disconnect the main power connector, then remove the B+ wire from the battery terminal.

WARNING! Insulate any tools used within the battery area to prevent sparks or battery explosion caused by shorting the battery terminals or wiring. Remove the batteries, or cover the exposed terminals with an insulating material.

Main Power Connector

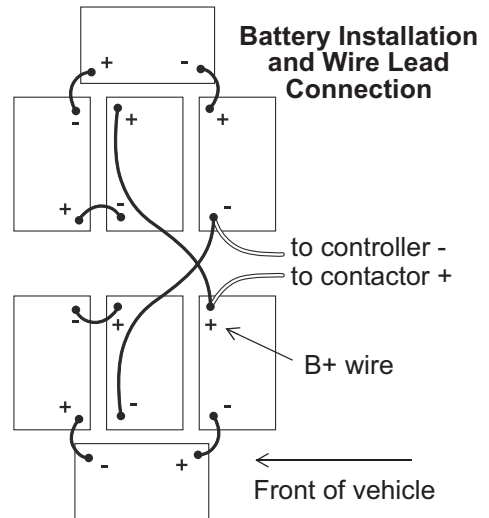
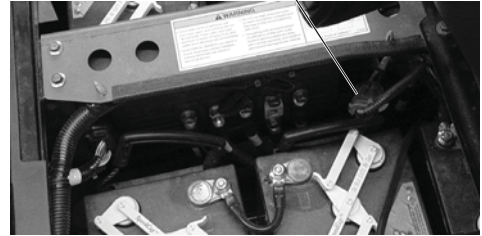

FEATURES AND CONTROLS

Trailer Hitch Bracket

This vehicle is equipped with a receiver hitch bracket for a trailer hitch. Trailer towing equipment is not supplied with this vehicle.

To avoid injury and property damage, always heed the warnings and towing capacities outlined on pages 35-36.

Brake Pedal

Push the brake pedal toward the floor to slow or stop the vehicle. Apply the brakes before turning the key on.

Accelerator Pedal

The accelerator pedal will function only when the key is ON and the direction selector switch is set to either forward or reverse. To begin moving or to increase vehicle speed, gradually push the accelerator pedal toward the floor. Holding the accelerator pedal down continuously will accelerate the vehicle to the maximum speed.

To slow the vehicle, release the accelerator pedal. Electric motor braking provides braking when the pedal is released. For additional speed control or to stop the vehicle, apply the service brakes.

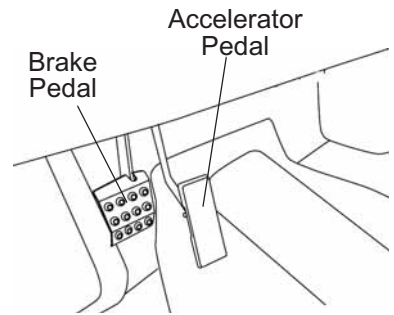

Roll-Over Protection System (ROPS)

The Rollover Protective Structure (ROPS) on this vehicle meets OSHA 1928.53 rollover performance requirements. Always have your authorized POLARIS dealer thoroughly inspect the ROPS if it ever becomes damaged in any way.

No device can assure occupant protection in the event of a rollover. Always follow all safe operating practices outlined in this manual to avoid vehicle rollover.

WARNING! Vehicle rollover could cause severe injury or death. Always avoid operating in a manner that could result in vehicle rollover.

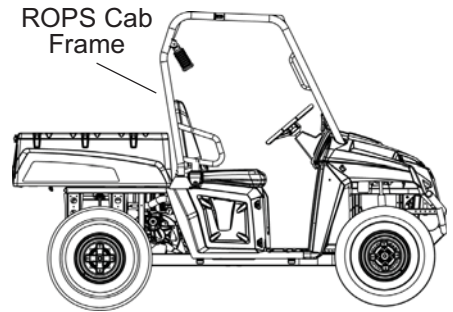

Seat Removal

Pull up on the front of the seat to disengage the front latches. Slide the seat forward and lift it away from the seat base.

To reinstall the seat, align the rear seat tabs with the slots on the rear of the seat base. Slide the seat fully rearward, then push down firmly along the front edge of the seat to secure the latches.

FEATURES AND CONTROLS

Seat Belts

This POLARIS vehicle is equipped with three-point lap and diagonal seat belts for the operator and passenger. Always make sure the seat belts are secured for all riders before operating.

The center of the seat is NOT equipped with a seat belt. Never allow a passenger to ride between the operator and passenger seats.

WARNING! Falling from a moving vehicle could result in serious injury or death. Always fasten your seat belt securely before operating or riding in the *RANGER*.

To wear the seat belt properly, follow this procedure:

1. For 3-point belts, pull the seat belt latch downward and across your chest toward the buckle at the inner edge of the seat. The belt should fit snugly across your hips and diagonally across your chest. Make sure the belt is not twisted.
2. Push the latch plate into the buckle until it clicks.
3. Release the strap, it will self tighten.
4. To release the seat belt, press the square red button in the buckle's center.

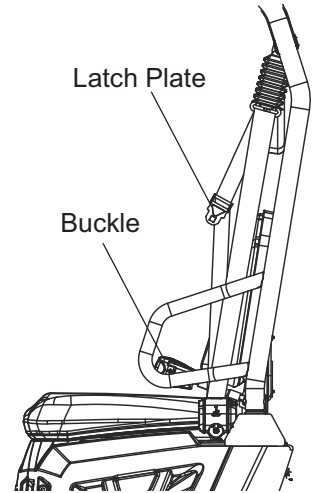

Seat Belt Inspection

Inspect all seat belts for proper operation before each use of the vehicle.

1. Push the latch plate into the buckle until it clicks. The latch plate must slide smoothly into the buckle. A click indicates that it's securely latched.
2. Push the red release latch in the middle of the buckle to make sure it releases freely.
3. Pull each seat belt completely out and inspect the full length for any damage, including cuts, wear, fraying or stiffness. If any damage is found, or if the seat belt does not operate properly, have the seat belt system checked and/or replaced by an authorized POLARIS dealer.
4. To clean dirt or debris from the seat belts, sponge the straps with mild soap and water. Do not use bleach, dye or household detergents.

⚠ WARNING

Failure to operate the vehicle properly can result in a collision, loss of control, accident or overturn, which may result in serious injury or death. Read and understand all safety warnings outlined in the safety section of this owner's manual.

Pre-Ride Inspection

Failure to inspect and verify that the vehicle is in safe operating condition before operating increases the risk of an accident. Always inspect the vehicle before each use to make sure it's in safe operating condition.

| Item | Remarks | Page |
|------------------------------|--|----------|
| Brake system/pedal travel | Ensure proper operation | 27 44 |
| Brake fluid | Ensure proper level | 44 |
| Front suspension | Inspect, lubricate if necessary | 41 |
| Rear suspension | Inspect, lubricate if necessary | 41 |
| Steering | Ensure free operation | 45 |
| Tires | Inspect condition and pressure | 6 46 |
| Wheels/fasteners | Inspect, ensure fastener tightness | 46 |
| Frame nuts, bolts, fasteners | Inspect, ensure tightness | - |
| Accelerator | Ensure proper operation | 27 |
| Indicator lights/switches | Ensure operation | 22 |
| Headlamp | Check operation, apply POLARIS dielectric grease when lamp is replaced | 47 |
| Brake light/tail lamp | Check operation, apply POLARIS dielectric grease when lamp is replaced | 48 |
| Seat belts | Check length of belt for damage, check latches for proper operation | 28 |
| Latches (hood/tailgate/seat) | Ensure all latches are secure | - |
| Batteries | Ensure full charges, proper water levels, clean terminals | 49-51 |
| Battery cables | Inspect for proper cable routing and secure connections | 51 |

OPERATION

Driving Procedure

1. Disconnect the charging cable (if connected).
 2. Wear a helmet, eye protection, gloves, long-sleeve shirt, long pants and over-the-ankle boots.
 3. Sit in the driver's seat and fasten the seat belt.
 4. Apply the brakes. Place the direction selector in neutral (N).
 5. Turn the key to the ON position. Wait about a second for the contactor to close before continuing.
 6. Move the direction selector to forward or reverse.
 7. Move the drive mode switch to the desired setting. See page 20.
 8. Release the park brake.
 9. Check your surroundings and determine your path of travel.
 10. Keeping both hands on the steering wheel, release the brake pedal and gradually push the accelerator toward the floor to begin driving.
 11. Drive slowly. Practice maneuvering and using the accelerator and brakes on level surfaces.
 12. Do not carry a passenger until you have at least two hours of driving experience with this vehicle. Never carry more than one passenger in this vehicle. Never allow a passenger to ride in the cargo box.
 13. To stop the vehicle, release the accelerator pedal completely and brake to a complete stop.
- Tip:** Always come to a complete stop before reversing direction.
14. Set the park brake.
 15. Place the direction selector in neutral.
 16. Turn the key off.



WARNING! A rolling vehicle can cause serious injury. Always set the park brake when leaving the vehicle unattended.

Driving On Slippery Surfaces

⚠ WARNING

Skidding or sliding can cause loss of control or overturn (if tires regain traction unexpectedly). When operating on slippery surfaces such as ice or loose gravel, reduce speed and use extra caution to reduce the chance of skidding or sliding out of control. Do not operate on excessively slippery surfaces.

Whenever riding on slippery surfaces such as wet trails or loose gravel, or during freezing weather, follow these precautions:

1. Do not operate on excessively rough, slippery or loose terrain.
2. Slow down before entering slippery areas.
3. Maintain a high level of alertness, reading the trail and avoiding quick, sharp turns, which can cause skids.
4. Engage all-wheel drive before wheels begin to lose traction.

NOTICE: Severe damage to the drive train may occur if the AWD is engaged while the wheels are spinning. Always allow the wheels to stop spinning before engaging AWD.

5. Correct a skid by turning the steering wheel in the direction of the skid. *Never apply the brakes during a skid.*

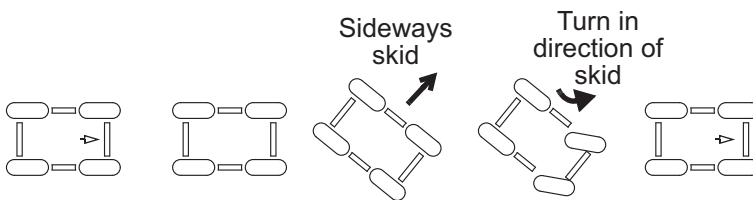

OPERATION

Driving Uphill

Whenever traveling uphill, follow these precautions:

1. Always travel straight uphill.
2. Avoid steep hills (15° maximum).
3. Keep both feet on the floor.
4. Always check the terrain carefully before ascending any hill.
5. Never climb hills with excessively slippery or loose surfaces.
6. Proceed at a steady rate of speed.
7. Never go over the crest of a hill at high speed. An obstacle, a sharp drop, or another vehicle or person could be on the other side of the hill.
8. If the vehicle stalls while climbing a hill, apply the brakes. Place the direction selector in neutral, turn the key off and on, then select low range. Place the direction selector switch in reverse and slowly allow the vehicle to roll straight downhill while applying light brake pressure to control speed.

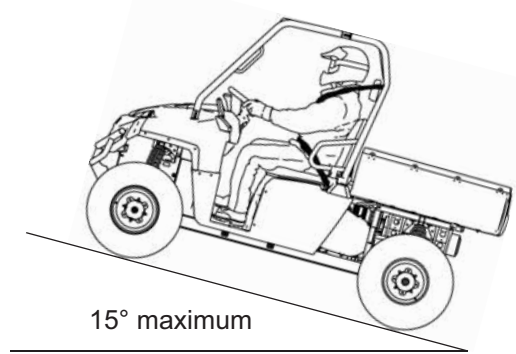

Driving on a Sidehill (Sidehilling)

Driving on a sidehill is not recommended. Improper procedure could cause loss of control or overturn. Avoid crossing the side of any hill unless absolutely necessary.

If crossing a sidehill is *unavoidable*, follow these precautions:

1. Slow down.
2. Exercise extreme caution.
3. Avoid crossing the side of a steep hill (15° maximum).

Driving Downhill

When driving downhill, follow these precautions:

1. Avoid steep hills (15° maximum).
2. Always descend a hill with the direction selector switch on forward. Never descend a hill with the switch on neutral.
3. Drive straight downhill. Avoid descending a hill at an angle, which would cause the vehicle to lean sharply to one side. Travel straight downhill when possible.
4. Slow down.
5. Apply the brakes *slightly* to aid in slowing.

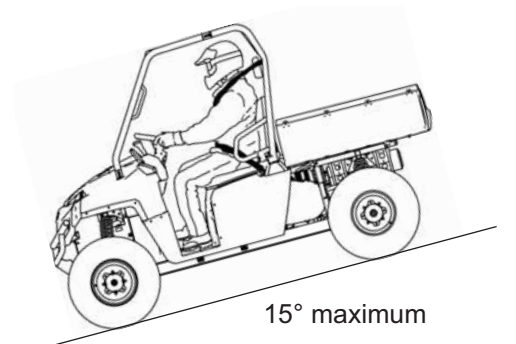

Driving Through Water

Your POLARIS vehicle can operate through water up to a maximum recommended depth equal to the floorboards.

NOTICE: Serious damage can occur to the electrical system and batteries if the vehicle is operated in water deeper than the floorboards.

Follow these procedures when operating through water:

1. Determine water depths and current before entering water.
2. Choose a crossing where both banks have gradual inclines.
3. Proceed slowly, avoiding rocks and obstacles.
4. Avoid operating through deep or fast-flowing water.
5. After leaving water, always dry the brakes by applying light pressure to the pedal repeatedly until braking action is normal.

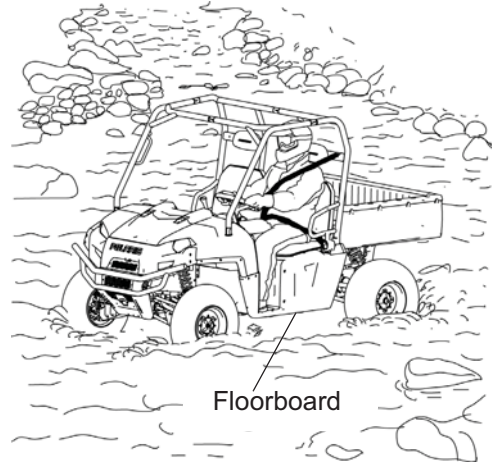

Driving Over Obstacles

Follow these precautions when operating over obstacles:

1. Always check for obstacles before operating in a new area.
2. Look ahead and learn to read the terrain. Be constantly alert for hazards such as logs, rocks and low hanging branches.
3. Travel slowly and use extra caution when operating on unfamiliar terrain. Not all obstacles are immediately visible.
4. Move the drive mode switch to low mode if needed. See page 20.



OPERATION

Driving in Reverse

Follow these precautions when operating in reverse:

1. Always check for obstacles or people behind the vehicle. Always inspect left and right fields of vision before backing.
2. Always avoid backing downhill.
3. Back slowly.
4. Apply the brakes *lightly* for stopping.
5. Avoid turning at sharp angles.
6. Never accelerate suddenly.



Parking on an Incline

Avoid parking on an incline if possible. If it's unavoidable, follow these precautions:

1. Apply the brakes.
2. Set the park brake.
3. Place the direction selector in neutral.
4. Turn the key off.
5. Block the rear wheels on the downhill side.

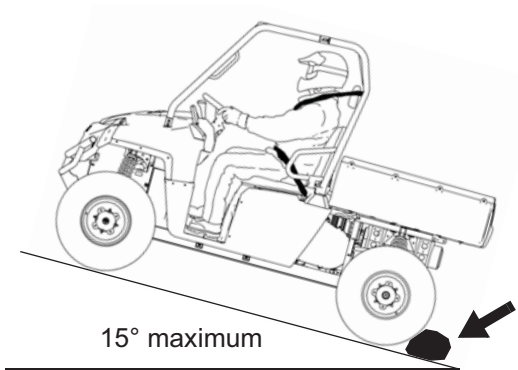

Hauling Cargo

⚠ WARNING

Hauling cargo improperly can alter vehicle handling and may cause loss of control or brake instability, which can result in serious injury or death. Always follow these precautions when hauling cargo:

Never exceed the maximum weight capacity of the vehicle. When determining the weight you are adding to the vehicle, include the weight of the operator, passenger, accessories, loads in the rack or box and the load on the trailer tongue. The combined weight of these items must not exceed the maximum weight capacity.

REDUCE SPEED AND ALLOW GREATER DISTANCES FOR BRAKING WHEN HAULING CARGO.

Always load the cargo box with the load as far forward and as low as possible.

When operating over rough or hilly terrain, reduce speed and cargo to maintain stable driving conditions.

Always operate the vehicle with extreme care when hauling or towing loads.

Slow down and drive in the lowest gear available.

SECURE ALL LOADS BEFORE OPERATING. Unsecured loads can create unstable operating conditions, which could result in loss of control of the vehicle.

OPERATE ONLY WITH STABLE AND SAFELY ARRANGED LOADS. When handling off-centered loads that cannot be centered, securely fasten the load and operate with extra caution. Always attach the tow load to the hitch point designated for your vehicle.

HEAVY LOADS CAN CAUSE BRAKING AND CONTROL PROBLEMS. Use extreme caution when applying brakes with a loaded vehicle. Avoid terrain or situations that may require backing downhill.

USE EXTREME CAUTION when operating with loads that extend over the rack sides. Stability and maneuverability may be adversely affected, causing the vehicle to overturn.

DO NOT TRAVEL FASTER THAN THE RECOMMENDED SPEEDS. Vehicle should never exceed 10 MPH (16 km/h) while towing a load on a level grass surface. Vehicle speed should never exceed 5 MPH (8 km/h) when towing loads in rough terrain, while cornering, or while ascending or descending a hill.

The *RANGER* has been designed to carry or tow specific capacities. Always read and understand the load distribution warnings listed on the warning labels. Move the drive mode switch to low mode if needed. See page 20.

The total load (operator, passenger, accessories, cargo and weight on hitch) must not exceed the maximum weight capacity of the vehicle. Never exceed the following capacities.

| Model | Maximum Capacities (Level Ground) | Cargo Box |
|------------------|--------------------------------------|-------------------|
| <i>RANGER EV</i> | 1000 lbs. (455 kg) | 500 lbs. (227 kg) |

WARNING! Driving with passengers in the cargo box can result in severe injury or death. Never allow passengers to ride in the cargo box. A passengers must always ride in the cab with seat belt fastened securely.



OPERATION

Towing Loads

Towing improperly can alter vehicle handling and may cause loss of control or brake instability. Always follow these precautions when towing:

1. Never load more than 150 lbs. (68.1 kg) tongue weight on the towing bracket.
2. Do not operate the vehicle faster than 10 MPH (16 km/h) when towing. See page 35. Towing a trailer increases braking distance.
3. Do not tow more than the recommended weight for the vehicle. See the towing capacity chart below and the specifications charts beginning on page 56.
4. Attach a trailer to the trailer hitch bracket only. Do not attach a trailer to any other location or you may lose control of the vehicle.
5. Never tow a trailer on a grade steeper than 15°.

| Model | Total Towed Load Weight (Level Ground) | Total Towed Load Weight (15° grade) | Total Hitch Vertical Weight | Maximum Towing Speed |
|------------------|--|-------------------------------------|-----------------------------|----------------------|
| <i>RANGER EV</i> | 1250 lbs. (567 kg) | 850 lbs. (386 kg) | 150 lbs. (68.1 kg) | 10 MPH (16 kph) |

Towing the *RANGER*

NOTICE: When towing the vehicle, the key **MUST** be in the OFF position or severe motor damage will occur.

Follow these procedures when towing the vehicle:

1. Place the direction selector in neutral.
2. Turn the key off.
3. Always follow these precautions when towing this vehicle:
 - Do not operate faster than 10 MPH (16 km/h).
 - Do not tow on public streets.
 - Do not allow passengers in the towed vehicle.
 - Avoid abrupt starts and stops.
 - Avoid sharp turns and abrupt steering maneuvers.
 - Avoid towing on a hill.

Dumping the Cargo Box

1. Select a level site to dump the cargo box. Do not attempt to dump or unload the vehicle while parked on an incline.
2. Apply the brakes.
3. Set the park brake.
4. Place the direction selector in neutral.
5. Turn the key off.
6. Dismount the vehicle.
7. Ensure that the cargo is positioned evenly or toward the front of the cargo box.
8. Release the tailgate latches.



WARNING! If the weight distribution on the box is located toward the rear of the box when the release lever is pulled forward, the box may dump unexpectedly and cause serious injury to the operator or bystanders. Never operate the dump lever without ensuring that the load is positioned evenly or at the front of the box.

9. Stand clear and pull up on the cargo box release lever.
10. Lift the front of the cargo box to dump the cargo.
11. Lower the cargo box and push down securely to latch.
12. Close the tailgate and secure both tailgate latches.

WARNING! Operating the vehicle while the cargo box is raised could result in severe injury. The box could close unexpectedly and cause injury to the driver or passenger. The rear tires will also catch the rear of a raised box, damaging the vehicle and creating hazardous driving conditions. Never operate this vehicle with the cargo box in the raised position.

OPERATION

Parking the *RANGER*

1. Apply the brakes. Stop the vehicle on a level surface.
2. When parking inside a garage or other structure, be sure that the structure is well ventilated and that the vehicle is not close to any source of flame or sparks, including any appliance with pilot lights.
3. Place the direction selector in neutral.
4. Set the park brake.
5. Turn the key off. Remove the key to prevent unauthorized use.

Transporting the *RANGER*

When transporting the *RANGER* for a long distance or on public streets, always use a trailer with an approved load rating greater than the *RANGER*'s curb vehicle weight of 1700 lbs. (771 kg) plus any installed accessories or cargo.

Follow these guidelines when transporting the *RANGER*.

1. Place the direction selector in neutral.
2. Set the park brake.
3. Remove the key to prevent loss.
4. Secure the seat, hood and tailgate latches.
5. Always tie the frame of the *RANGER* to the transporting unit securely with suitable straps.
6. If using an open trailer, remove the windshield (if equipped).
7. Never allow passengers on a trailer or in a trailered vehicle.
8. Reduce speed and drive with caution.

All Wheel Drive (AWD)

Press the top of the rocker switch to engage All Wheel Drive (AWD). Once enabled, the AWD remains enabled until the switch is turned off.

The AWD switch may be turned on or off while the vehicle is moving. When the AWD switch is on, the front gearcase will automatically engage any time the rear wheels lose traction. When the rear wheels regain traction, the front gearcase will automatically disengage.

Tip: AWD will not engage initially until speed is less than 5 MPH (8 km/h).

Engage the AWD before getting into conditions where front wheel drive may be needed. If the rear wheels are spinning, release the accelerator before switching to AWD.

NOTICE: Switching to AWD while the rear wheels are spinning may cause severe drive train damage. Always switch to AWD while the rear wheels have traction or are at rest.

Locking the Differential

NOTICE: Damage to the differential can occur if it is engaged while the vehicle is traveling at high speeds or while the rear wheels are spinning. Slow the vehicle to nearly stopped before engaging the differential.

Locking the differential in slippery or low traction conditions helps improve traction. Move the rocker switch to the center position (2WD) to lock the differential and operate in rear wheel drive.

Press the bottom of the switch to unlock the differential and allow the rear drive wheels to operate independently. This mode of operation is well suited to turf driving or whenever aggressive traction is not required.

Disengaging AWD

Move the AWD switch to the center or bottom position to disengage AWD.

If the switch is turned off while the front gearcase is moving, it will not disengage until the rear wheels regain traction.

In some situations, the front gearcase may remain locked after turning the AWD switch off. If this occurs, you may notice increased steering effort and some vehicle speed restriction. Perform the following procedure to unlock the front gearcase.

1. Stop the vehicle.
2. Move the direction selector to reverse. Operate in reverse for at least 10 feet (3 m).
3. Stop completely.
4. Move the direction selector to forward and drive forward.
5. If the front gearcase remains locked after following these instructions, return the vehicle to your dealer for service.

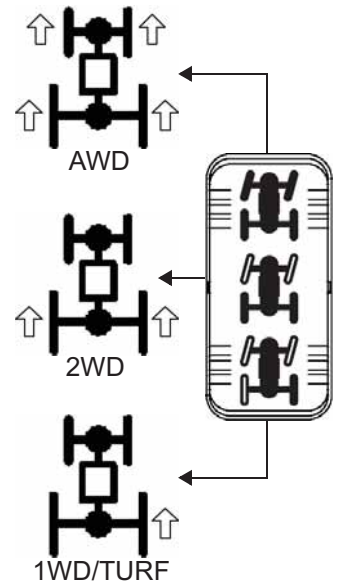

MAINTENANCE

Periodic Maintenance Chart

Careful periodic maintenance will help keep your vehicle in the safest, most reliable condition. Inspection, adjustment and lubrication of important components are explained in the periodic maintenance chart.

Inspect, clean, lubricate, adjust and replace parts as necessary. When inspection reveals the need for replacement parts, use genuine POLARIS parts available from your POLARIS dealer.

Record maintenance and service in the Maintenance Log beginning on page 62.

Tip: Service and adjustments are important for proper vehicle operation. If you're not familiar with safe service and adjustment procedures, have a qualified dealer perform these operations.

Maintenance intervals in the following chart are based upon average riding conditions and an average vehicle speed of approximately 10 MPH (16 km/h). Vehicles subjected to severe use must be inspected and serviced more frequently.

Severe Use Definition

- Frequent immersion in mud, water or sand
- Racing or race-style high RPM use
- Prolonged low speed, heavy load operation

Maintenance Chart Key

► Perform these operations more often for vehicles subjected to severe use.

D Have an authorized POLARIS dealer perform these services.

WARNING! Improperly performing the procedures marked with a “**D**” could result in component failure and lead to serious injury or death. Have an authorized POLARIS dealer perform these services.

Periodic Maintenance Chart

Perform all services at whichever maintenance interval is reached first.

| Item | Maintenance Interval (whichever comes first) | | | Remarks |
|---------------------------------|---|----------|------------|--|
| | Hours | Calendar | Miles (Km) | |
| Steering | - | Pre-Ride | - | Inspect and make adjustments as needed. See Pre-Ride Checklist on page 29. |
| Front suspension | - | | - | |
| Rear suspension | - | | - | |
| Tires | - | | - | |
| Brake fluid level | - | | - | |
| Brake pedal travel | - | | - | |
| Brake system | - | | - | |
| Wheels/fasteners | - | | - | |
| Frame fasteners | - | | - | |
| Batteries | - | | - | |
| Headlamp/tail lamp | - | | Daily | |
| ► D Brake pad wear | 10 H | Monthly | - | Inspect periodically |
| Battery terminals | 25 H | Monthly | - | Inspect and clean (page 51) |
| Battery fluid levels | 25 H | Monthly | - | Add as needed (page 51) |
| Battery terminals | 25 H | Monthly | - | Inspect; torque to specification |
| ► Front gearcase oil | 25 H | 1 M | - | Perform a break-in oil level check |
| ► Main gearcase oil (Transaxle) | 25 H | 1 M | - | Perform a break-in oil level check |
| ► General lubrication | 50 H | 3 M | - | Lubricate all fittings, pivots, cables, etc. |
| D Steering | 50 H | 6 M | - | Lubricate |
| ► Front Suspension | 50 H | 6 M | - | Lubricate |
| ► Rear Suspension | 50 H | 6 M | - | Lubricate |
| ► Front gearcase oil | 100 H | 12 M | - | Perform a break-in oil level check |
| ► Main gearcase oil (Transaxle) | 100 H | 12 M | - | Perform a break-in oil level check |
| ► Wiring | 100 H | 12 M | - | Inspect for wear, routing, security; apply dielectric grease to connectors subjected to water, mud, etc. |
| D Front wheel bearings | 100 H | 12 M | - | Inspect; replace as needed |
| D Brake fluid | 200 H | 24 M | - | Change every two years |
| D Toe adjustment | | - | | Inspect periodically; adjust when parts are replaced |
| D Headlight aim | | - | | Adjust as needed |

- Perform these procedures more often for vehicles subjected to severe use.
- D Have an authorized POLARIS dealer perform these services.

Lubrication Recommendations

Check and lubricate all components at the intervals outlined in the Periodic Maintenance Chart beginning on page 40, or more often under severe use, such as wet or dusty conditions. Items not listed in the chart should be lubricated at the general lubrication interval.

| Item | Lube | Method |
|-------------------------------|-------------------------------|--------------|
| Brake Fluid | DOT 4 | See page 44. |
| Main Gearcase Oil (Transaxle) | Premium ATV Angle Drive Fluid | See page 42. |
| Front Gearcase Oil | Demand Drive Plus Fluid | See page 43. |

MAINTENANCE

Gearcases

Gearcase Specification Chart

| Gearcase | Lubricant | Capacity | Fill Plug Torque | Drain Plug Torque |
|---------------------------|-------------------------------|-------------------|----------------------------|-----------------------|
| Main Gearcase (Transaxle) | Premium ATV Angle Drive Fluid | 20.3 oz. (600 ml) | 14 ft. lbs. (19.4 Nm) | 14 ft. lbs. (19.4 Nm) |
| Front Gearcase | Demand Drive Plus Fluid | 5.1 oz. (150 ml) | 8-10 ft. lbs. (11-13.6 Nm) | 11 ft. lbs. (15 Nm) |

Main Gearcase (Transaxle)

Always check and change the main gearcase oil at the intervals outlined in the Periodic Maintenance Chart beginning on page 40. Maintain the oil level even with the bottom thread of the fill plug hole.

Refer to the Gearcase Specifications Chart for recommended lubricants, capacities and torque specifications. See page 57 for the part numbers of POLARIS products.

Oil Check

The fill plug is located at the right rear of the vehicle.

1. Position the vehicle on a level surface.
2. Remove the fill plug.
3. Check the oil level.
4. Add the recommended oil as needed.
5. Reinstall the fill plug. Torque to specification.

Oil Change

The drain plug is located on the lower right side of the main gearcase, near the fill plug. Refer to the Gearcase Specifications Chart for recommended lubricants, capacities and torque specifications.

1. Remove the fill plug.
2. Place a drain pan under the drain plug. Remove the drain plug. Allow the oil to drain completely.
3. Wipe the magnetic end of the drain plug clean to remove accumulated metallic filings.
4. Reinstall the drain plug. Torque to specification.
5. Add the recommended oil as needed. Do not overfill.
6. Reinstall the fill plug. Torque to specification.
7. Check for leaks. Dispose of used oil properly.

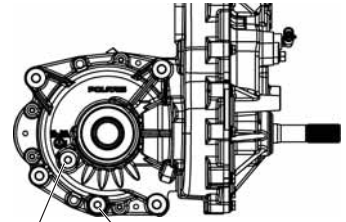

Fill Plug Drain Plug

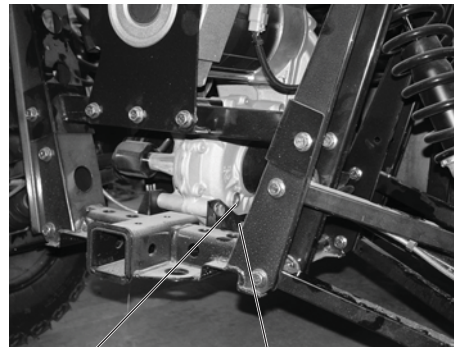

Fill Plug Drain Plug

Gearcases

Front Gearcase

Always check and change the front gearcase oil at the intervals outlined in the Periodic Maintenance Chart beginning on page 40. Maintain the oil level even with the bottom thread of the fill plug hole.

Refer to the Gearcase Specifications Chart on page 42 for recommended lubricants, capacities and torque specifications. See page 57 for the part numbers of POLARIS products.

Oil Check

The front gearcase fill plug is located on the left side of the front gearcase.

1. Position the vehicle on a level surface.
2. Remove the fill plug. Check the oil level.
3. Add the recommended oil as needed.
4. Reinstall the fill plug. Torque to specification.

Oil Change

1. Support the vehicle securely with a jackstand.
2. Remove the front tire on the driver's side.
3. Remove the fill plug.
4. Place a drain pan under the drain plug.
5. Remove the drain plug. Allow the oil to drain completely.
6. Clean the drain plug. Reinstall the drain plug. Torque to specification.
7. Add the recommended oil.
8. Reinstall the fill plug. Torque to specification.
9. Check for leaks.
10. Discard used oil properly.



Fill Plug

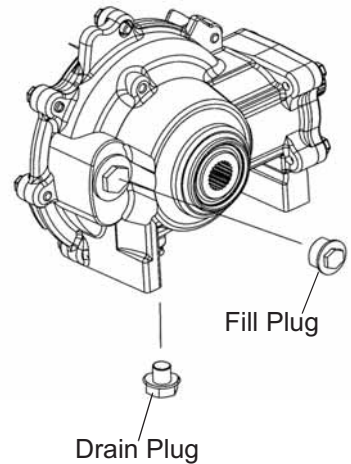

MAINTENANCE

Brakes

The front and rear brakes are hydraulic disc type brakes. Press down on the brake pedal to engage the brakes. See page 27.

Brake Fluid

Inspect the brake system routinely. Inspect the level of the brake fluid before each operation.

WARNING! After opening a bottle of brake fluid, always discard any unused portion. Never store or use a partial bottle. Brake fluid is hygroscopic, meaning it rapidly absorbs moisture from the air. The moisture causes the boiling temperature of the brake fluid to drop, which can lead to early brake fade and the possibility of accident or severe injury.

Change the brake fluid every two years and any time the fluid becomes contaminated, the fluid level is below the minimum, or if the type and brand of the fluid in the reservoir are unknown. See page 41 for fluid recommendations.

1. Position the vehicle on a level surface.
2. View the brake fluid level at the reservoir in the driver's side wheel well. The level should be between the upper (MAX) and lower (MIN) level lines.
3. If the fluid level is lower than the upper level line, add brake fluid to the upper (MAX) line.
4. Apply the brake forcefully for a few seconds and check for fluid leakage around the fittings.

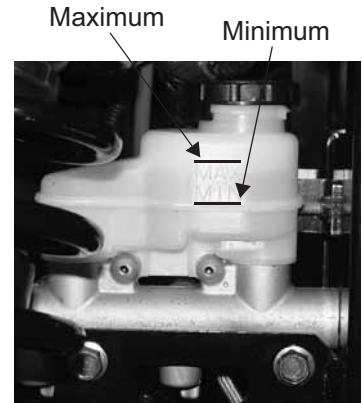

Brake Inspection

1. Check the brake system for fluid leaks.
2. Check the brake pedal for excessive travel or a spongy feel.
3. Check the friction pads for wear, damage and looseness. Change pads when worn to 3/64" (1 mm).
4. Check the security and surface condition of the disc. Clean any grease using a recommended brake cleaner or alcohol. Do not use spray lubricants or other petroleum-based products. If you discover any damage (cracks, excessive corrosion, warping) see your dealer for service before operating.

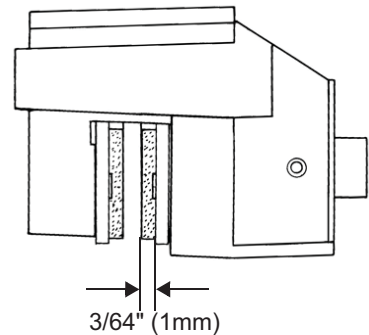

Steering Wheel Inspection

Check the steering wheel for specified freeplay and smooth operation at the intervals outlined in the Periodic Maintenance Chart beginning on page 40.

1. Position the vehicle on a level surface.
2. Lightly turn the steering wheel left and right. There should be 0.8"-1.0" (20-25 mm) of freeplay at the outer rim of the steering wheel.
3. If there is excessive freeplay or strange noises, or the steering feels rough or "catchy," have the steering system inspected by an authorized POLARIS dealer.

Spring Adjustment

Adjust the rear shock absorber springs by rotating the adjustment cams either clockwise or counter-clockwise to increase or decrease spring tension.

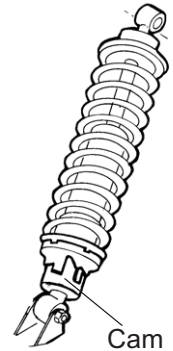

MAINTENANCE

Tires

⚠ WARNING

Operating your vehicle with worn tires, improperly inflated tires, non-standard tires or improperly installed tires will affect vehicle handling and could cause an accident resulting in serious injury or death. Always follow all tire maintenance procedures as outlined in this manual and on the labels on the vehicle. Always use original equipment size and type when replacing tires.

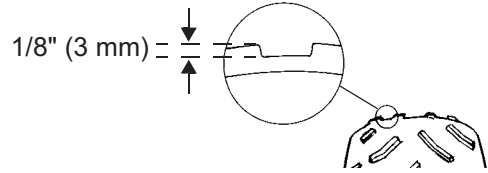

Tire Tread Depth

Always replace tires when tread depth is worn to 1/8" (3 mm) or less.

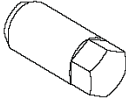

Axle and Wheel Nut Torque Specifications

Inspect the following items occasionally for tightness, and if they've been loosened for maintenance service. Do not lubricate the stud or the lug nut.

| Nut Type | Location | Nut Torque |
|---|-----------------|--|
| Lug Nut (Aluminum Wheels)  | Front and Rear | 30 ft. lbs. (41 Nm) PLUS 1/4 TURN (90 degrees) |
| Nut and Washer (Steel Wheels)  | Front and Rear | 35 ft. lbs. (47 Nm) |
| Spindle Nut | Front | 70 ft. lbs. (95 Nm) |
| Hub Retaining Nuts | Center and Rear | 110 ft. lbs. (150 Nm) |

Wheel Removal

1. Apply the brakes. Set the park brake. Turn the key off.
2. Loosen the wheel nuts slightly.
3. Elevate the side of the vehicle by placing a suitable stand under the frame.
4. Remove the wheel nuts and washers. Remove the wheel.

Wheel Installation

1. Set the park brake. Place the wheel in the correct position on the wheel hub. Be sure the valve stem is toward the outside and rotation arrows on the tire point toward forward rotation.

WARNING! Improperly installed wheels can adversely affect tire wear and vehicle handling, which can result in serious injury or death. Always ensure that all nuts are torqued to specification. Do not service axle nuts that have a cotter pin installed. See your POLARIS dealer.

2. Attach the wheel nuts and washers and finger tighten.
3. Carefully lower the vehicle to the ground.
4. Torque the wheel nuts to specification. See page 46.

Lights

Poor lighting can result in reduced visibility when driving. Headlight and taillight lenses become dirty during normal operation. Clean lights frequently and replace burned out lamps promptly. Always make sure lights are adjusted properly for best visibility.

When servicing a halogen lamp, don't touch the lamp with bare fingers. Oil from your skin leaves a residue, causing a hot spot that will shorten the life of the lamp.

Headlight Lamp Replacement

1. Open the hood.

CAUTION! Hot components can cause burns to skin. Allow lamps to cool before servicing.

2. Unplug the headlamp from the wiring harness. Be sure to pull on the connector, not on the wiring.
3. Turn the lamp counter-clockwise to remove it.
4. Install the new lamp.

Tip: Make sure the tab on the lamp locates properly in the housing.

5. Reinstall the harness assembly into the headlight assembly.



Headlight Beam Adjustment

1. Place the vehicle on a level surface with the headlight approximately 25 ft. (7.6 m) from a wall.
2. Measure the distance from the floor to the center of the headlight and make a mark on the wall at the same height.
3. Apply the brakes. Turn the key on. Turn the headlights on.
4. Observe the headlight aim. The most intense part of the headlight beam should be aimed 8" (20 cm) below the mark placed on the wall. Include the weight of a rider on the seat while performing this step.
5. If a headlight needs adjustment, access the adjustment screw under the hood or through the wheel well.
6. Loosen the screw, adjust the headlight, and tighten the screw.
7. Repeat steps 4-6 until the lamp is properly adjusted.

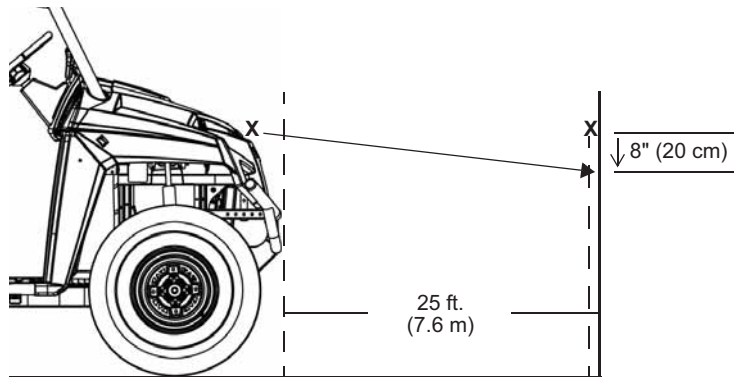

MAINTENANCE

Lights

Brake Lights

When the brake pedal is depressed, the brake light comes on. Check the brake light before each ride.

1. Turn the key to the ON position.
2. Depress the brake pedal. The brake light should come on after about 10mm (0.4 in.) of pedal travel. If the light doesn't come on, check the bulb.

Indicator Lamp Replacement

1. Lift the hood.
2. Reach in behind the console panel and lift the release to unplug the light from the harness.
3. Using a flathead screwdriver, press on the tab on the top of the light to remove the indicator light assembly from the console panel.
4. Locate the expired lamp. Using a screwdriver, rotate the lamp 1/4 turn counter-clockwise.
5. Grip the lamp with a needle-nose pliers and remove it from the assembly.
6. Install the new lamp. Using a screwdriver, rotate the lamp 1/4 turn clockwise to seat it.
7. Snap the assembly back into the console panel. Reconnect the harness.
8. Close the hood.

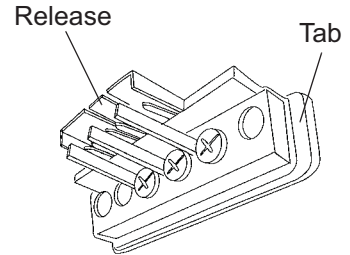

Batteries

⚠ WARNING

Battery posts, terminals and related components contain lead and lead compounds, chemicals known to cause cancer and reproductive harm. Always wash your hands after touching or handling the batteries.

⚠ WARNING

Charging a damaged battery can result in serious injury. Never attempt to charge a frozen or bulging battery. Discard the battery appropriately and install a new battery.

⚠ WARNING

Improperly connecting or disconnecting battery cables can result in an explosion and cause serious injury or death.

⚠ WARNING

Battery electrolyte is poisonous. It contains sulfuric acid. Serious burns can result from contact with skin, eyes or clothing.

Antidote:

External: Flush with water.

Internal: Drink large quantities of water or milk. Follow with milk of magnesia, beaten egg, or vegetable oil. Call physician immediately.

Eyes: Flush with water for 15 minutes and get prompt medical attention.

Batteries produce explosive gases. Keep sparks, flame, cigarettes, etc. away. Ventilate when charging or using in an enclosed space. Always shield eyes when working near batteries. KEEP OUT OF REACH OF CHILDREN.

MAINTENANCE

Batteries

Battery Charging

When not in use, park the vehicle and connect the battery charger. The vehicle's charging cord is located inside the charge plug holder on the console.

WARNING! Failure to provide adequate ventilation while charging batteries can result in an explosion. Hydrogen gas is emitted during charging and will rise and accumulate at the ceiling. Always ensure a minimum of five (5) air changes per hour in the charging area. Never charge the batteries in an area subject to a flame or spark, including areas containing gas or propane water heaters and furnaces. Do not smoke in the charging area.

Always follow these precautions when charging the batteries:

1. Position the vehicle on a level surface.
 2. Make sure the charging area is well ventilated.
 3. Make sure the key is off.
 4. Open the hood and any door enclosures or zippers.
 5. Always use an extension cord with a minimum rating of 20 amps.
 6. Inspect the charging cord and extension cord for cracks, loose connections and frayed wiring. Replace any damaged components promptly.
 7. Always connect the vehicle charger to the extension cord first, then plug the cord into a wall receptacle.
 8. Make sure the charger uses a dedicated circuit to prevent overloading. If charging multiple vehicles, each vehicle should use a dedicated circuit.
- Tip:** After the batteries have fully recharged, the battery charger will automatically cycle in and out of the trickle charge mode to maintain the charge.
9. When disconnecting the charger, always disconnect the extension cord from the wall receptacle first, then disconnect the cord from the vehicle's charging cord.



Charging Cord

Batteries

Battery Access

To access the batteries, remove the seat. See page 27. Remove the storage tray (if equipped).

NOTICE: Before removing the seat to access the batteries, make sure any wire or metal items (including seat belt latches) remain clear of the battery compartment to avoid causing a short circuit to the electrical system.

Battery Inspections

Inspect battery terminal connections monthly. Clean batteries as recommended. Using an insulated wrench, torque bolts to 8 ft. lbs. (11 Nm).

Battery Cleaning

Always keep battery terminals and connections free of corrosion. To clean, remove corrosion with a stiff wire brush. Wash with a solution of one tablespoon baking soda and one cup water. Rinse well with tap water and dry off with clean shop towels. Coat battery terminals with dielectric grease or petroleum jelly.

NOTICE: Do not allow cleaning solution or tap water to enter the batteries.

Battery Replacement

With proper care and maintenance as outlined in this owner's manual, battery life could be extended up to four years or longer, depending on the amount of use. When battery replacement is necessary, please see your authorized POLARIS dealer.

WARNING! Handling batteries and electrical components improperly can result in serious injury or death. Do not attempt to remove batteries or battery cables. Always see your dealer for battery-related service.

Battery Fluid

A poorly maintained battery will deteriorate rapidly. Check the battery fluid level often. *Add only distilled water.* Tap water contains minerals that are harmful to a battery.

Unless the plates are exposed before charging, distilled water should be added to a battery *after* charging. If the plates are exposed, add water to about 1/8 inch (3 mm) above the plates, then charge. Check the fluid level again after charging. Maintain the fluid level 1/4 inch (6 mm) below the bottom of the fill well in the cell cover. Do not overfill.

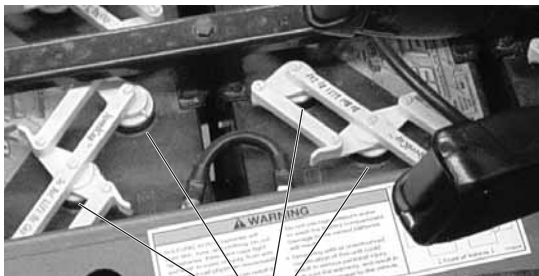

Cell Covers

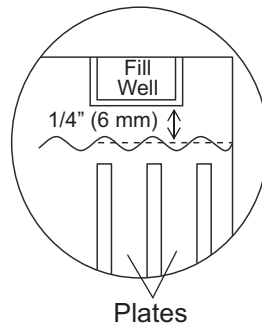

Plates

MAINTENANCE

Cleaning and Storage

Washing the Vehicle

Keeping your POLARIS vehicle clean will not only improve its appearance but it can also extend the life of various components.

NOTICE: High water pressure may damage components. POLARIS recommends washing the vehicle by hand or with a garden hose, using mild soap.

NOTICE: Certain products, including insect repellents and chemicals, will damage plastic surfaces. Do not allow these types of products to contact the vehicle.

The best and safest way to clean your POLARIS vehicle is with a garden hose and a pail of mild soap and water.

1. Use a professional-type washing cloth, cleaning the upper body first and the lower parts last.
2. Rinse with clean water frequently.
3. Dry surfaces with a chamois to prevent water spots.

Washing Tips

- Avoid the use of harsh cleaners, which can scratch the finish.
- Do not use a power washer to clean the vehicle.
- Do not use medium to heavy duty compounds on the finish.
- Always use clean cloths and pads for cleaning and polishing. Old or reused cloths and pads may contain dirt particles that will scratch the finish.
- Avoid directing water toward electrical components, including batteries, wiring and switches.

Washing the Vehicle

If a high pressure water system is used for cleaning (not recommended), exercise extreme caution. The water may damage components and could remove paint and labels. Avoid directing the water stream at the following items:

- Wheel bearings
- Main gearcase seals
- Brakes
- Cab and body panels
- Labels and decals
- Switches and controls
- Electrical components and wiring

If an informational or graphic label becomes illegible or comes off, contact your POLARIS dealer to purchase a replacement. Replacement *safety* labels are provided by POLARIS at no charge.

Grease all zerk fittings immediately after washing.

Cleaning and Storage

Polishing the Vehicle

POLARIS recommends the use of common household aerosol furniture polish for polishing the finish on your POLARIS vehicle. Follow the instructions on the container.

Polishing Tips

- Avoid the use of automotive products, some of which can scratch the finish of your vehicle.
- Always use clean cloths and pads for cleaning and polishing. Old or reused cloths and pads may contain dirt particles that will scratch the finish.

Chrome Wheel Care (if equipped)

Proper maintenance will protect chrome wheels from corrosion, preserve wheel life and ensure a “like new” appearance for many years. Chrome wheels exposed to road salt (or salt in the air in coastal areas) are more susceptible to corrosion if not properly cleaned. Clean chrome wheels more often if they're exposed to salt or other corrosive elements.

1. Wash chrome wheels frequently. Use a mild detergent. Never use abrasive cleaners on plated or painted surfaces.
2. Rinse well with clear water. Soap, detergents, salt, dirt, mud and other elements can cause corrosion.
3. Polish the clean chrome wheels periodically. Use an automotive grade chrome polish.
4. Routinely and liberally apply a weather resistant wax to each polished chrome wheel. Choose a product suitable for chrome finishes. Read and follow the product labels and instructions.

Removing Corrosion

If light rust is found on the chrome finish, use steel wool (#0000-OTT grade) to remove it. Gently rub the affected areas with the steel wool until the corrosion has been removed. Clean and polish the wheel as outlined above.

MAINTENANCE

Cleaning and Storage

Storage Tips

Clean the Exterior

Make any necessary repairs and clean the vehicle as recommended. See page 52.

Inspect and Lubricate

Inspect all cables and lubricate all areas of the vehicle as recommended in the Periodic Maintenance Chart beginning on page 40.

Battery Maintenance

See pages 49-51 for procedures.

Fluid Levels

Inspect the fluid levels. Add or change fluids as recommended in the Periodic Maintenance Chart beginning on page 40.

- Front and rear gearcase fluid (if equipped)
- Main gearcase fluid
- Brake fluid (change every two years and any time the fluid looks dark or contaminated)

Storing the Vehicle

Any time the vehicle will be parked for more than a few hours, follow the recommended storage procedures:

1. Make any necessary repairs and clean the vehicle. See page 52.
2. Clean the batteries. See page 51.
3. Store the vehicle out of the sun in a cool, dry place.
4. Be sure the storage area is well ventilated.
5. Turn the key off.
6. *Do not* set the park brake.
7. Verify that tire pressure is at specification.
8. Block the wheels to prevent rolling.
9. Fully charge the batteries. Leave the charger connected to maintain a full charge during the storage period, or check battery voltage each month during storage and recharge as needed to maintain a full charge. If the charger remains connected, check it monthly to verify proper operation.

Tip: Do not use plastic or coated materials. They do not allow enough ventilation to prevent condensation, and may promote corrosion and oxidation.

WARNING! Do not cover the vehicle while the charger is connected. Dangerous levels of hydrogen gas could accumulate.

Removal from Storage

1. Inspect all battery connections.
2. Verify that batteries are fully charged.
3. Verify that tire pressure is at specification.
4. Perform the pre-ride inspection. See page 29.
5. Inspect and verify the tightness of the bolts, nuts and other fasteners.
6. Lubricate at the intervals outlined in the Periodic Maintenance Chart beginning on page 40.

SPECIFICATIONS

| RANGER EV | |
|--|---|
| Dimensions | |
| Dry Weight | 1750 lbs. (793.8 kg) |
| Ground Clearance | 10 in. (25.4 cm) |
| Length | 108 in. (274.3 cm) |
| Width | 56.5 in. (143.5 cm) |
| Height | 73 in. (185.4 cm) |
| Wheelbase | 72 in. (183 cm) |
| Turning Radius | 150 in. (381 cm) |
| Load Capacity | |
| Box Dimensions (Inside) | 32 x 42 x 11.5 in. (81 x 107 x 29 cm) |
| Box Capacity | 500 lbs. (227 kg) |
| Payload Capacity | 1000 lbs. (455 kg) |
| Hitch Towing Capacity | 1250 lbs. (567 kg) |
| Cargo System | Lock & Ride® |
| Seating | 2 |
| Skid Plate | Plastic |
| Performance | |
| Motor configuration | Single, 48-volt, high efficiency, AC induction motor |
| Motor peak | 30 HP |
| Controller | 650 - Amp Sevcon Gen IV controller with multi-mode driving and regenerative braking |
| Battery pack | 11.7 kw battery pack at 48V DC with 8 12-volt, US12VXC batteries in series-parallel configuration |
| Maximum speed | 25 MPH (40.2 km/h) |
| Range (in Max Range mode on flat ground) | 50 miles (80.5 km) (may vary with driving conditions) |
| Throttle | Redundant, non-contact, inductive-sensing pedal |
| On-board charger | Delta Q 120-volt AC input; 48-volt DC output |
| Charge time | 8 hours (dependent on depth of discharge) |
| Drivetrain | |
| Main gearcase (transaxle) | Direct drive motor-to-transaxle with low-noise gears |
| Drive | On demand AWD, 2WD, turf mode |

SPECIFICATIONS

| RANGER EV | |
|------------------------------------|--|
| Brake System | |
| Brakes | 4-Wheel hydraulic disc w/dual bore front calipers |
| Park Brake | Dash-mounted lever-activated mechanical park brake |
| Suspension | |
| Front suspension | Independent Macpherson struts w/8 in. (20.3 cm) travel |
| Rear suspension | Dual A-Arm w/9 in. (22.9 cm) travel |
| Tires | 25x9-12 Carlisle All Trail II |
| Tire pressure | 20 psi (137.9 kPa) |
| Features | |
| Cup holders | Dual cup holders |
| Indicator panel | Indicates directional selection, park brake, and motor or controller malfunction |
| Charge indicator | Digital, indicates battery discharge |
| Hour meter | Digital, indicates cumulative hours of vehicle movement |
| Auxiliary power | 12-volt accessory outlet |
| Rider restraints | Automotive-style 3-point seat belts |
| Multi-mode switch | L/M/H (Low/Max Range/High) |
| Headlights/taillights/brake lights | Dual 50-watt |
| Storage | Glove box |

POLARIS PRODUCTS

| Part Number | Description |
|--|---|
| Gearcase Lubricants | |
| 2871653 | Premium ATV Angle Drive Fluid (8 oz./237 ml) |
| 2872276 | Premium ATV Angle Drive Fluid (2.5 gal./9.5 l) |
| 2877922 | Demand Drive Plus Fluid (qt./.95 l) |
| 2877923 | Demand Drive Plus Fluid (2.5 gal./9.5 l) |
| Grease / Specialized Lubricants | |
| 2871312 | Grease Gun Kit, Premium All Season |
| 2871322 | Premium All Season Grease (3 oz./89 ml cartridge) |
| 2871423 | Premium All Season Grease (14 oz./414 ml cartridge) |
| 2871515 | Premium U-Joint Lube (3 oz./89 ml cartridge) |
| 2871551 | Premium U-Joint Lube (14 oz./414 ml cartridge) |
| 2871329 | Dielectric Grease (Nyogel™) |
| Additives / Miscellaneous | |
| 2872189 | DOT 4 Brake Fluid |

TROUBLESHOOTING

Vehicle Will Not Operate

| Possible Cause | Solution |
|--|---|
| Low battery voltage | Recharge the battery overnight |
| Loose battery connections | Check all connections and tighten |
| Loose contactor connections | Check all connections and tighten |
| Loose electronic control box connections | Inspect, clean, reinstall connectors |
| Required torque exceeds motor capability | In neutral, cycle key off and on, select low range, then select direction |

LIMITED WARRANTY

POLARIS Sales Inc., 2100 Highway 55, Medina, MN 55340, gives a SIX MONTH LIMITED WARRANTY on all components of the POLARIS *RANGER* against defects in material or workmanship. Warranty period will vary by region. POLARIS also supports a one year limited supplier warranty covering defects in material or workmanship on the factory-installed 12-volt batteries in the 48-volt system.

This warranty covers the parts and labor charges for repair or replacement of defective parts which are covered by this warranty. This warranty begins on the date of purchase. This warranty is transferable to another consumer during the warranty period through a POLARIS dealer.

REGISTRATION

At the time of sale, the Warranty Registration Form must be completed by your dealer and submitted to POLARIS within ten days. Upon receipt of this registration, POLARIS will record the registration for warranty. No verification of registration will be sent to the purchaser as the copy of the Warranty Registration Form will be the warranty entitlement. If you have not signed the original registration and received the customer copy, please contact your dealer immediately. **NO WARRANTY COVERAGE WILL BE ALLOWED UNLESS YOUR VEHICLE IS REGISTERED WITH POLARIS.**

Initial dealer preparation and set-up of your vehicle is very important in ensuring trouble-free operation. Purchasing a machine in the crate or without proper dealer set-up will void your warranty coverage.

WARRANTY COVERAGE AND EXCLUSIONS: LIMITATIONS OF WARRANTIES AND REMEDIES

The POLARIS limited warranty excludes any failures that are not caused by a defect in material or workmanship. This warranty does not cover accidental damage, normal wear and tear, abuse or improper handling. This warranty also does not cover any vehicle that has been altered structurally, modified, neglected, improperly maintained, used for racing, or used for purposes other than for which it was manufactured, or for any damages which occur during trailer transit or as a result of unauthorized service or the use of unauthorized parts. In addition, this warranty does not cover physical damage to paint or finish, stress cracks, tearing or puncturing of upholstery material, corrosion, or defects in parts, components or the vehicle due to fire, explosions or any other cause beyond POLARIS' control.

Warranty does not apply to parts exposed to friction surfaces, stresses, environmental conditions and/or contamination for which they were not designed or not intended, including but not limited to the following items:

- Wheels and tires
- Suspension components
- Brake components
- Seat components
- Clutches and components
- Steering components
- Batteries
- Light bulbs/Sealed beam lamps
- Finished and unfinished surfaces
- Carburetor/Throttle body components
- Engine components
- Drive belts
- Hydraulic components
- Circuit breakers/Fuses
- Electronic components

Warranty applies to the product only and does not allow for coverage of personal loss. Some items are considered "consumable," meaning they are considered part of normal maintenance or part of completing an effective repair. The following items are excluded from warranty coverage in the event of a warranty claim:

- Filters
- Sealants
- Hotel fees
- Towing charges
- Mileage
- Rentals/Loss of product use
- Batteries (unless deemed defective by the POLARIS Warranty Department and the battery supplier)
- Lubricants such as oil, grease, etc.
- Cosmetic damage/repair
- Meals
- Shipping/ handling fees
- Product pick-up/delivery
- Loss of vacation/personal time

WARRANTY

LIMITATIONS OF WARRANTIES AND REMEDIES

This warranty also excludes failures resulting from improper lubrication; improper engine timing; improper fuel; surface imperfections caused by external stress, heat, cold or contamination; operator error or abuse; improper component alignment, tension, adjustment or altitude compensation; failure due to snow, water, dirt or other foreign substance ingestion/contamination; improper maintenance; modified components; use of aftermarket components resulting in failure; unauthorized repairs; repairs made after the warranty period expires or by an unauthorized repair center; use of the product in competition or for commercial purposes. Warranty will not apply to any product which has been damaged by abuse, accident, fire or any other casualty not determined a defect of materials or workmanship.

The POLARIS limited warranty excludes any battery failures that are not caused by a defect in material or workmanship. Warranty claims for battery replacements require specific testing as outlined by the POLARIS Warranty Department and the battery manufacturer, U.S. Battery, prior to replacement. If the POLARIS Warranty Department, in conjunction with U.S. Battery, determines that the failure of the battery is caused by a defect in material or workmanship, POLARIS will assist with the processing of the warranty claim through U.S. Battery for a replacement battery. This warranty does not cover the time required to test and/or diagnose issues with the battery. Consequential damage caused by defective batteries are excluded from this warranty. Use of any charger not recommended by POLARIS and/or modifications to the vehicle will void any stated or implied warranty on the battery. Battery warranty exclusions include damage caused by: abuse or neglect, such as improper fluid levels, loose wiring or rusted or corroded hardware; lack of proper maintenance; improper installation of the battery; neglect, breakage, freezing, fire, explosion or wreckage; the addition of any chemical; operation of the battery in an overcharged condition; operation of the battery in an uncharged condition (below half-charge - 1.200 specific gravity); and use of a battery charged by systems other than those supplied or recommended by POLARIS.

This warranty does not cover the use of unauthorized lubricants, chemicals, or fuels that are not compatible with the vehicle. The exclusive remedy for breach of this warranty shall be, at POLARIS' exclusive option, repair or replacement of any defective materials, or components or products. THE REMEDIES SET FORTH IN THIS WARRANTY ARE THE ONLY REMEDIES AVAILABLE TO ANY PERSON FOR BREACH OF THIS WARRANTY. POLARIS SHALL HAVE NO LIABILITY TO ANY PERSON FOR INCIDENTAL, CONSEQUENTIAL OR SPECIAL DAMAGES OF ANY DESCRIPTION, WHETHER ARISING OUT OF EXPRESS OR IMPLIED WARRANTY OR ANY OTHER CONTRACT, NEGLIGENCE, OR OTHER TORT OR OTHERWISE. THIS EXCLUSION OF CONSEQUENTIAL, INCIDENTAL, AND SPECIAL DAMAGES IS INDEPENDENT FROM AND SHALL SURVIVE ANY FINDING THAT THE EXCLUSIVE REMEDY FAILED OF ITS ESSENTIAL PURPOSE. Some states do not permit the exclusion or limitation of incidental or consequential damages or implied warranties, so the above limitations or exclusions may not apply to you if inconsistent with controlling state law.

U.S. Battery's liability shall be to replace the defective battery. Replacement shall mean furnishing a new battery or used battery with sufficient life to complete the warranty term, which is incidental or reasonably equivalent to the warranted product, at no cost to the purchaser during the replacement period.

ALL IMPLIED WARRANTIES (INCLUDING BUT NOT LIMITED TO THE IMPLIED WARRANTIES OF MERCHANTABILITY AND FITNESS FOR A PARTICULAR PURPOSE) ARE LIMITED IN DURATION TO THE ABOVE SIX MONTH WARRANTY PERIOD. POLARIS FURTHER DISCLAIMS ALL EXPRESS WARRANTIES NOT STATED IN THIS WARRANTY. Some states do not allow limitations on how long an implied warranty lasts, so the above limitation may not apply to you if inconsistent with controlling state law.

HOW TO OBTAIN WARRANTY SERVICE

If your vehicle requires warranty service, you must take it to a POLARIS Servicing Dealer. When requesting warranty service you must present your copy of the Warranty Registration form to the dealer. (THE COST OF TRANSPORTATION TO AND FROM THE DEALER IS YOUR RESPONSIBILITY). POLARIS suggests that you use your original selling dealer; however, you may use any POLARIS Servicing Dealer to perform warranty service.

Please work with your dealer to resolve any warranty issues. Should your dealer require any additional assistance they will contact the appropriate person at POLARIS.

This warranty gives you specific legal rights, and you may also have other rights which vary from state to state. If any of the above terms are void because of state or federal law, all other warranty terms will remain in effect.

Lubricants

Mixing lubricant brands or using non-recommended lubricants may cause component damage. We recommend the use of POLARIS lubricants for this vehicle. Damage resulting from the use of non-recommended lubricants may not be covered by warranty.

Exported Vehicles

EXCEPT WHERE SPECIFICALLY REQUIRED BY LAW, THERE IS NO WARRANTY OR SERVICE BULLETIN COVERAGE ON THIS VEHICLE IF IT IS SOLD OUTSIDE THE COUNTRY OF THE SELLING DEALER'S AUTHORIZED LOCATION.

This policy does not apply to vehicles that have received authorization for export from POLARIS Industries. Dealers may not give authorization for export. You should consult an authorized dealer to determine this vehicle's warranty or service bulletin coverage if you have any questions.

This policy does not apply to vehicles registered to government officials or military personnel on assignment outside the country of the selling dealer's authorized location.

This policy does not apply to Safety Bulletins.

How to Get Service

In the Country where your vehicle was purchased:

Warranty or Service Bulletin repairs must be done by an authorized POLARIS dealer. If you move or are traveling within the country where your vehicle was purchased, Warranty or Service Bulletin repairs may be requested from any authorized POLARIS dealer who sells the same line as your vehicle.

Outside the Country where your vehicle was purchased:

If you are traveling temporarily outside the country where your vehicle was purchased, you should take your vehicle to an authorized POLARIS dealer. You must show the dealer photo identification from the country of the selling dealer's authorized location as proof of residence. Upon residence verification, the servicing dealer will be authorized to perform the warranty repair.

If You Move:

If you move to another country, be sure to contact POLARIS Customer Assistance and the customs department of the destination country before you move. Vehicles importation rules vary considerably from country to country. You may be required to present documentation of your move to POLARIS Industries in order to continue your warranty coverage. You may also be required to obtain documentation from POLARIS Industries in order to register your vehicle in your new country. You should warranty register your vehicle at a local POLARIS dealer in your new country immediately after you move to continue your warranty coverage and to ensure that you receive safety information and notices regarding your vehicle.

If Purchased From A Private Party:

If you purchase a POLARIS product from a private citizen, to be kept and used outside of the country in which the vehicle was originally purchased, all warranty coverage will be denied. You must nonetheless warranty register your vehicle under your name and address with a local POLARIS dealer in your country to ensure that you receive safety information and notices regarding your vehicle.

Notice

If your vehicle is registered outside of the country where it was purchased, and you have not followed the procedure set out above, your vehicle will no longer be eligible for warranty or service bulletin coverage of any kind, other than *safety* bulletins. (Vehicles registered to Government officials or military personnel on assignment outside of the country where the vehicle was purchased will continue to be covered by the basic warranty.)

For questions call POLARIS Customer Assistance:

United States: 1-888-704-5290

Canada: 1-204-925-7100

MAINTENANCE LOG

Use the following chart to record periodic maintenance.

| DATE | MILES (KM) OR HOURS | TECHNICIAN | SERVICE PERFORMED / COMMENTS |
|------|------------------------|------------|------------------------------|
| | | | |
| | | | |
| | | | |
| | | | |
| | | | |
| | | | |
| | | | |
| | | | |
| | | | |
| | | | |
| | | | |
| | | | |
| | | | |
| | | | |
| | | | |
| | | | |
| | | | |
| | | | |
| | | | |
| | | | |
| | | | |

| | | | |
|--|--------|---|-------|
| A | | D | |
| Accelerator Pedal | 27 | Driving Downhill | 32 |
| All Wheel Drive | 39 | Driving in Reverse | 34 |
| Auxiliary 12-Volt Terminal Board | 18 | Driving on a Sidehill. | 32 |
| Auxiliary Outlets. | 18 | Driving on Slippery Surfaces | 31 |
| AWD | 39 | Driving Over Obstacles | 33 |
| AWD Switch. | 21 | Driving Procedure. | 30 |
| Axle Nut Torque | 46 | Driving Through Water | 33 |
| B | | Driving Uphill. | 32 |
| Batteries | | Dumping the Cargo Box | 37 |
| Accessing | 51 | E | |
| Ambient Temperature Implications | 25 | Equipment Modifications | 5 |
| Charge Status Indicator | 19, 23 | Eye Protection. | 9 |
| Charger Operation | 25 | F | |
| Charging. | 50 | Fluid Change | |
| Charging Cord | 18, 25 | Front Gearcase | 43 |
| Cleaning | 51 | Main Gearcase | 42 |
| Conditioning. | 25 | Transaxle | 42 |
| Discharge Indicator | 18 | Fluid Level | |
| Fluid | 51 | Front Gearcase | 43 |
| Handling Precautions | 24 | Main Gearcase | 42 |
| Inspections | 51 | Transaxle | 42 |
| Main Power Connector | 26 | Fluid Levels During Storage. | 54 |
| Operation Range | 25 | Fluid Recommendation, Gearcases | 42 |
| Replacement. | 51 | Fluid, Battery | 51 |
| Boots | 9 | Fluid, Brake | 44 |
| Brake Lever, Park | 19 | Front Gearcase | 43 |
| Brake Lights | 48 | Fuel Stabilizer | 54 |
| Brake Pedal | 27 | G | |
| Brakes | 44 | Gearcase Specification Chart | 42 |
| Brake Fluid | 44 | Gearcase, Front | 43 |
| Brake Inspection | 44 | Gearcase, Main | 42 |
| C | | Gearcases | 42-43 |
| Cab Frame, ROPS. | 27 | Gloves | 9 |
| Cargo | 35 | H | |
| Cargo Box, Dumping | 37 | Hauling Cargo. | 35 |
| Charge Status Indicator. | 19, 23 | Headlight Beam Adjustment. | 47 |
| Charger Operation. | 25 | Headlight Lamp Replacement | 47 |
| Charging Batteries | 50 | Headlight Switch | 21 |
| Charging Cord. | 18 | Helmet. | 9 |
| Chrome Wheel Care | 53 | Hitch Bracket | 27 |
| Cleaning and Storage | 52-54 | Hitch Weight. | 36 |
| Clothing | 9 | Hour Meter | 18 |
| Component Locations | 16 | I | |
| Console | 17-22 | Indicator Light Replacement | 48 |
| Corrosion Removal, Chrome | 53 | Indicator Lights. | 22 |
| D | | Indicator, Charge Status | 19 |
| Differential Locking | 39 | K | |
| Direction Selector | 21 | Key Switch | 19 |
| Discharge Indicator. | 18 | Key, Periodic Maintenance Chart. | 40 |
| Disengaging AWD | 39 | | |
| Drive Mode Switch. | 20 | | |

INDEX

| | | | |
|--|-------|--|-------|
| L | | S | |
| Lamp Replacement, Indicator Lights | 48 | Safety Labels | 6-8 |
| Lights | | Safety Symbols | 4 |
| Brake Lights | 48 | Seat Belt Inspection | 28 |
| Headlight Beam Adjustment | 47 | Seat Belts | 28 |
| Headlight Lamp Replacement | 47 | Seat Removal | 27 |
| Indicator Lamp Replacement | 48 | Severe Use Definition | 40 |
| Indicator Lights | 22 | Shock Spring Adjustment | 45 |
| Lubrication Recommendations | 41 | Signal Words | 4 |
| M | | Specifications, Gearcase | 42 |
| Main Gearcase | 42 | Speed, Towing | 36 |
| Main Power Connector | 26 | Steering Wheel Inspection | 45 |
| Maintenance Log | 62 | Storage | 52-54 |
| Maintenance Precautions | 15 | Storage Tips | 54 |
| Maintenance, Periodic | 40-41 | Storage, Removal | 55 |
| Malfunction Indicator | 23 | Storing the Vehicle | 55 |
| Modifications | 5 | Switches | |
| O | | AWD Switch | 21 |
| Obstacles | 33 | Direction Selector | 21 |
| Oil Change | | Drive Mode Switch | 20 |
| Front Gearcase | 43 | Headlight Switch | 21 |
| Main Gearcase | 42 | Key Switch | 19 |
| Transaxle | 42 | T | |
| Oil Level | | Tire Pressure | 6 |
| Front Gearcase | 43 | Tires | |
| Main Gearcase | 42 | Nut Torque | 46 |
| Transaxle | 42 | Tread Depth | 46 |
| Operation Range | 25 | Wheel Installation | 46 |
| Operator Safety | 10-15 | Wheel Removal | 46 |
| P | | Towing Loads | 36 |
| Park Brake Lever | 19 | Towing Speed | 36 |
| Parking on an Incline | 34 | Towing the RANGER | 36 |
| Parking the RANGER | 38 | Trailer Hitch Bracket | 27 |
| Periodic Maintenance Chart | 40-41 | Transaxle | 42 |
| Polaris Products | 57 | Transporting the RANGER | 38 |
| Polishing the Vehicle | 53 | Troubleshooting | |
| Pre-Ride Inspection | 29 | Charge Status Indicator | 23 |
| Pressure, Tire | 6 | Malfunction Indicator | 23 |
| R | | Vehicle Will Not Operate | 58 |
| Range of Operation | 25 | V | |
| Removing the Vehicle from Storage | 55 | Vehicle Identification Numbers | 5 |
| Reverse Operaton | 34 | Vehicle Range | 25 |
| Riding Gear | 9 | Vehicle Will Not Operate | 58 |
| Roll-Over Protection System | 27 | W | |
| ROPS Cab Frame | 27 | Warning Symbols | 4 |
| | | Washing the Vehicle | 52 |
| | | Weight, Hitch | 36 |
| | | Wheel Installation | 46 |
| | | Wheel Nut Torque | 46 |
| | | Wheel Removal | 46 |