

# POLARIS® RANGER® 400



## ***RANGER***® 400

**Owner's Manual**  
**for Maintenance and Safety**

**⚠ WARNING**

Read, understand, and follow all of the instructions and safety precautions in this manual and on all product labels.

Failure to follow the safety precautions could result in serious injury or death.

**⚠ WARNING**

The engine exhaust from this product contains chemicals known to the State of California to cause cancer, birth defects or other reproductive harm.

# WELCOME

Thank you for purchasing a POLARIS vehicle, and welcome to our world-wide family of POLARIS enthusiasts. Be sure to visit us online at [www.polaris.com](http://www.polaris.com) for the latest news, new product introductions, upcoming events, career opportunities and more.

Here at POLARIS we proudly produce an exciting line of utility and recreational products.

- Snowmobiles
- All-terrain vehicles (ATVs)
- Low emission vehicles (LEVs)
- *RANGER*® utility vehicles
- *RZR*® sport vehicles
- *VICTORY*® motorcycles
- *GEM*® electric vehicles

We believe POLARIS sets a standard of excellence for all utility and recreational vehicles manufactured in the world today. Many years of experience have gone into the engineering, design, and development of your POLARIS vehicle, making it the finest machine we've ever produced.

For safe and enjoyable operation of your vehicle, be sure to follow the instructions and recommendations in this owner's manual. Your manual contains instructions for minor maintenance, but information about major repairs is outlined in the POLARIS Service Manual and should be performed only by a factory certified Master Service Dealer® (MSD) technician.

Your POLARIS dealer knows your vehicle best and is interested in your total satisfaction. Be sure to return to your dealership for all of your service needs during, and after, the warranty period.



**POLARIS**®

POLARIS®, *RANGER*® and *RANGER CREW*® are registered trademarks of POLARIS Industries Inc.

Copyright 2013 POLARIS Sales Inc. All information contained within this publication is based on the latest product information at the time of publication. Due to constant improvements in the design and quality of production components, some minor discrepancies may result between the actual vehicle and the information presented in this publication. Depictions and/or procedures in this publication are intended for reference use only. No liability can be accepted for omissions or inaccuracies. Any reprinting or reuse of the depictions and/or procedures contained within, whether whole or in part, is expressly prohibited.

The original instructions for this vehicle are in English. Other languages are provided as translations of the original instructions.

Printed in U.S.A.

2014 *RANGER* 400 Owner's Manual

P/N 9924302

# TABLE OF CONTENTS

<b>Introduction</b> .....	<b>4</b>
<b>Safety</b> .....	<b>8</b>
<b>Features and Controls</b> .....	<b>21</b>
<b>Operation</b> .....	<b>28</b>
<b>Winch Guide</b> .....	<b>42</b>
<b>Emission Control Systems</b> .....	<b>51</b>
<b>Maintenance</b> .....	<b>52</b>
<b>POLARIS Products</b> .....	<b>85</b>
<b>Specifications</b> .....	<b>86</b>
<b>Troubleshooting</b> .....	<b>88</b>
<b>Warranty</b> .....	<b>92</b>
<b>Maintenance Log</b> .....	<b>98</b>
<b>Index</b> .....	<b>101</b>

# INTRODUCTION

The *RANGER* is an off-road vehicle. Familiarize yourself with all laws and regulations concerning the operation of this vehicle in your area.

The following signal words and symbols appear throughout this manual and on your vehicle. Your safety is involved when these words and symbols are used. Become familiar with their meanings before reading the manual.



The safety alert symbol indicates a potential personal injury hazard.

## **DANGER**

A **DANGER** indicates a hazardous situation that, if not avoided, will result in death or serious injury.

## **WARNING**

A **WARNING** indicates a hazardous situation that, if not avoided, could result in death or serious injury.

## **CAUTION**

A **CAUTION** indicates a hazardous situation that, if not avoided, could result in minor or moderate injury.

## **NOTICE**

A **NOTICE** indicates a situation that could result in property damage.



The Prohibition Safety Sign indicates an action **NOT** to take in order to avoid a hazard.



The Mandatory Action Sign indicates an action that **NEEDS** to be taken to avoid a hazard.

## WARNING

Failure to follow the warnings contained in this manual can result in severe injury or death.

Your POLARIS *RANGER* is not a toy and can be hazardous to operate. This vehicle handles differently than other vehicles, such as cars, trucks or other off-road vehicles. A collision or rollover can occur quickly, even during routine maneuvers like turning, or driving on hills or over obstacles, if you fail to take proper precautions.

- Read this owner's manual and review the safety DVD that came with your vehicle. A free extra copy of the DVD can be obtained by contacting your local POLARIS dealer. Understand all safety warnings, precautions and operating procedures before operating the vehicle. Keep this manual with the vehicle.
- Review the safety DVD and take the free online Recreational Off-Highway Vehicle Association (ROHVA) training course at [www.rohva.org](http://www.rohva.org).
- This vehicle is an ADULT VEHICLE ONLY. You MUST be at least age 16 and have a valid driver's license to operate this vehicle.
- No person under the age of 12 may ride as a passenger in this vehicle. All riders must be able to sit with backs against the seat, both feet flat on the floor and both hands on the steering wheel (if driving) or on a passenger hand hold.
- Never permit a guest to operate this vehicle unless the guest has read this manual and all product labels.
- Always use the cab nets (or doors) while riding in this vehicle. Always keep hands, feet and all other body parts inside the vehicle at all times.
- Always wear a helmet, eye protection, gloves, long-sleeve shirt, long pants and over-the-ankle boots.
- Never use this vehicle with drugs or alcohol, as these conditions impair judgment and reduce operator reaction time.

# INTRODUCTION

## Vehicle Identification Numbers

Record your vehicle's identification numbers and key number in the spaces provided. Remove the spare key and store it in a safe place. An ignition key can be duplicated only by ordering a POLARIS key blank (using your key number) and mating it with one of your existing keys. The ignition switch must be replaced if all keys are lost.



VIN

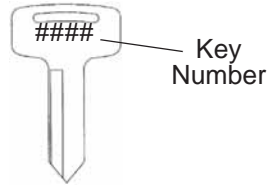

Vehicle Model Number: \_\_\_\_\_

Frame VIN: \_\_\_\_\_

Engine Serial Number: \_\_\_\_\_  
(label on side of engine)

Key Number: \_\_\_\_\_



## European Vibration and Noise

The driver-perceived noise and hand/arm and whole body vibration levels of this machinery is measured per prEN 15997.

The operating conditions of the machinery during testing:

The vehicles were in like-new condition. The environment was controlled as indicated by the test procedure(s).

The uncertainty of vibration exposure measurement is dependent on many factors, including:

- Instrument and calibration uncertainty
- Variations in the machine such as wear of components
- Variation of machine operators such as experience or physique
- Ability of the worker to reproduce typical work during measurements
- Environmental factors such as ambient noise or temperature

# SAFETY

## Safe Riding Gear

The driver and all passengers must wear helmet, eye protection, gloves, long-sleeve shirt, long pants, over-the-ankle boots and seat belt at all times. Protective gear reduces the chance of injury.

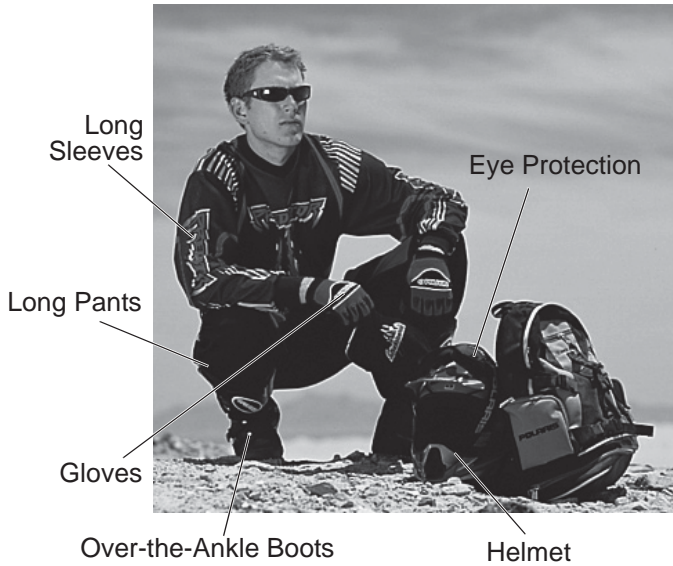

### Helmet

Wearing a helmet can prevent a severe head injury. Whenever riding this POLARIS vehicle, always wear a helmet that meets or exceeds established safety standards.

Approved helmets in the USA and Canada bear a U.S. Department of Transportation (DOT) label.

Approved helmets in Europe, Asia and Oceania bear the ECE 22.05 label. The ECE mark consists of a circle surrounding the letter E, followed by the distinguishing number of the country which has granted approval. The approval number and serial number will also be displayed on the label.

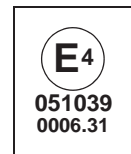

## Safe Riding Gear

### Eye Protection

Do not depend on eyeglasses or sunglasses for eye protection. Whenever riding this POLARIS vehicle, always wear shatterproof goggles or use a shatterproof helmet face shield. POLARIS recommends wearing approved Personal Protective Equipment (PPE) bearing markings such as VESC 8, V-8, Z87.1, or CE. Make sure protective eye wear is kept clean.

### Gloves

Wear gloves for comfort and for protection from sun, cold weather and other elements.

### Boots

Wear sturdy over-the-ankle boots for support and protection. Never ride a POLARIS vehicle with bare feet or sandals.

### Clothing

Wear long sleeves and long pants to protect arms and legs.

### Rider Comfort

Under certain operating conditions, heat generated by the engine and exhaust system can elevate temperatures in the driver and passenger cab area. The condition occurs most frequently when a vehicle is being operated in high ambient temperatures at low speeds and/or high load conditions for an extended period of time. The use of certain windshield, roof and/or cab systems may contribute to this condition by restricting airflow. Any discomfort due to heat buildup in this area can be minimized by wearing proper riding apparel and by varying speeds to increase airflow.

# SAFETY

## Safety Labels and Locations

Warning labels have been placed on the vehicle for your protection. Read and follow the instructions of the labels on the vehicle carefully. If any of the labels depicted in this manual differ from the labels on your vehicle, always read and follow the instructions of the labels *on the vehicle*.

If any label becomes illegible or comes off, contact your POLARIS dealer to purchase a replacement. Replacement *safety* labels are provided by POLARIS at no charge. The part number is printed on the label.



### Max Payload Warning

WARNING

RANGER Mid Size	Never Exceed	If Total Payload Exceeds
400	35 mph (56 kph)	700 lbs. (317 kg)

7180136

### Proper Use Warning

Require Proper Use of Your Vehicle

Do your part to prevent injuries:

- Do not allow careless or reckless driving.
- Make sure operators are 16 or older with a valid driver's license.
- Do not let people drive or ride after using alcohol or drugs.
- Do not allow operation on public roads (unless designated for off-highway vehicle access) - collisions with cars and trucks can occur.
- Do not exceed seating capacity: 2 occupants.

7179978

## Safety Labels and Locations

### Seat Belt/Drive Responsibly Warning

#### WARNING

Improper vehicle use can result in SEVERE INJURY or DEATH

#### Be Prepared

- Fasten seat belts.
- Wear an approved helmet and protective gear.
- ALWAYS use vehicle cab nets and/or doors.
- Each rider must be able to sit with back against seat, feet flat on the floor, and hands on steering wheel or hand holds. Stay completely inside the vehicle.

#### Drive Responsibly

Avoid loss of control and rollovers:

- Avoid abrupt maneuvers, sideways sliding, skidding or fishtailing, and never do donuts.
- Slow down before entering a turn.
- Avoid hard acceleration when turning, even from a stop.
- Plan for hills, rough terrain, ruts and other changes in traction and terrain. Avoid paved surfaces.
- Avoid sidehilling (riding across slopes).

#### Be Sure Riders Pay Attention and Plan Ahead

If you think or feel the vehicle may tip or roll, reduce your risk of injury:

- Keep a firm grip on the steering wheel or hand holds and brace yourself.
- Do not put any part of your body outside of the vehicle for any reason.

LOCATE AND READ OWNER'S MANUAL. FOLLOW ALL INSTRUCTIONS AND WARNINGS. ALWAYS REVIEW SAFETY VIDEO AND TAKE ROHVA TRAINING ([rohva.org](http://rohva.org)).



Rollovers have caused severe injuries and death, even on flat, open areas.

7179982

# SAFETY

## Passenger/Tire Pressure Warning

### WARNING

- Passengers can be thrown off. This can cause serious injury or death.
- Never carry passengers in cargo box.

### WARNING

IMPROPER TIRE PRESSURE OR OVERLOADING CAN CAUSE LOSS OF CONTROL RESULTING IN SERIOUS INJURY OR DEATH.

- Reduce speed and allow greater distance for braking when carrying cargo.
- Overloading or carrying tall, off-center, or unsecured loads will increase your risk of losing control. Loads should be centered and carried as low as possible in box.
- For stability on rough or hilly terrain, reduce speed and cargo.
- Be careful if load extends over the side of the box.

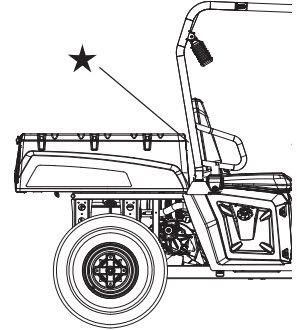

<b>RANGER MID-SIZE</b>	<b>400</b>
<b>MAXIMUM CARGO BOX LOAD</b>	500 lbs. (226 kg)
<b>TIRE PRESSURE IN PSI (KPa)</b>	FRONT 10 (69) REAR 10 (69)
<b>MAXIMUM WEIGHT CAPACITY INCLUDES WEIGHT OF OPERATOR, PASSENGER, CARGO AND ACCESSORIES</b>	1000 lbs. (454 kg)
<b>Read Operation &amp; Maintenance Manual for more detailed loading information.</b>	

7179550

## Clutch Cover Warning

### WARNING

- Moving parts hazard under belt-clutch guard. To prevent serious injury, do not operate vehicle with guard removed.
- Do not modify engine or clutch. Doing so can cause part failure, possible imbalance, and excessive engine RPM which can result in serious injury or death.

7175488

Clutch  
Cover  
Warning

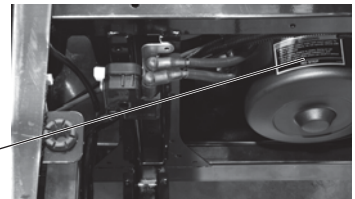

## Shift Caution

### CAUTION

To avoid transmission damage, shift only when vehicle is stationary and at idle.

APPLY BRAKE TO START. When this vehicle is not in operation, or unattended, place shift in the park position.

7176170

Shift  
Caution



## Operator Safety

### **⚠ WARNING**

Serious injury or death can result if you do not follow these instructions and procedures, which are outlined in further detail within your owner's manual.

- Read this entire manual and all labels carefully. Follow the operating procedures described.
- Never allow anyone under the age of 16 to operate this vehicle and never allow anyone without a valid driver's license to operate this vehicle.
- Do not carry a passenger until you have at least two hours of driving experience with this vehicle.
- No person under the age of 12 may ride as a passenger in this vehicle. All riders must be able to sit with backs against the seat, both feet flat on the floor and both hands on the steering wheel (if driving) or on a passenger hand hold.
- The driver and all passengers must wear helmet, eye protection, gloves, long-sleeve shirt, long pants, over-the-ankle boots and seat belt at all times.
- Always use the cab nets (or doors) while riding in this vehicle.
- Always keep hands and feet inside the vehicle at all times.
- Always keep both hands on the steering wheel and both feet on the floorboards of the vehicle during operation.
- Never permit a guest to operate this vehicle unless the guest has read this manual and all product labels.
- To reduce rollover risk, be especially careful when encountering obstacles and slopes and when braking on hills or during turns.
- This vehicle is for off-road use only. Never operate on public roads (unless marked for off-road use). Always avoid paved surfaces.
- Never consume alcohol or drugs before or while operating this vehicle.
- Never operate at excessive speeds. Always travel at a speed proper for the terrain, visibility and operating conditions, and your experience.
- Never attempt jumps or other stunts.
- Always inspect the vehicle before each use to make sure it's in safe operating condition. Always follow the inspection procedures described in this manual.

# SAFETY

## Operator Safety

- Always travel slowly and use extra caution when operating on unfamiliar terrain. Be alert to changing terrain.
- Never operate on excessively rough, slippery or loose terrain.
- Always follow proper procedures for turning. Practice turning at slow speeds before attempting to turn at faster speeds. Never turn at excessive speeds.
- Always have this vehicle checked by an authorized POLARIS dealer if it has been involved in an accident.
- Never operate this vehicle on hills too steep for the vehicle or for your abilities. Practice on smaller hills before attempting larger hills.
- Always follow proper procedures for climbing hills as described in this manual. See page 35. Check the terrain carefully before attempting to climb a hill. Never climb hills with excessively slippery or loose surfaces. Never apply throttle suddenly. Never make sudden gear changes. Never go over the top of a hill at high speed.
- Always follow the proper procedures outlined in this manual for traveling downhill and for braking on hills. See page 35. Check the terrain carefully before descending a hill. Never travel downhill at high speed. Avoid going downhill at an angle, which would cause the vehicle to lean sharply to one side. Travel straight down the hill where possible.
- Always check for obstacles before operating in a new area. Never attempt to operate over large obstacles such as large rocks or fallen trees. Always follow the proper procedures outlined in this manual when operating over obstacles. See page 33.
- Always be careful of skidding or sliding. On slippery surfaces such as ice, travel slowly and exercise caution to reduce the chance of skidding or sliding out of control.
- Never operate your vehicle in fast-flowing water or in water deeper than that specified in this manual. See page 36. Wet brakes may have reduced stopping ability. Test your brakes after leaving water. If necessary, apply them lightly several times to let friction dry out the pads.
- Always be sure there are no obstacles or people behind your vehicle when operating in reverse. When it's safe to proceed in reverse, move slowly. Avoid turning at sharp angles in reverse.



## Operator Safety

- Always use the proper size and type of tires specified in this manual. Always maintain proper tire pressure as specified on safety labels.
- Never modify this vehicle through improper installation or use of non-POLARIS-approved accessories.
- Never exceed the stated load capacity for this vehicle. Cargo should be properly distributed and securely attached. Reduce speed and follow the instructions in this manual for hauling cargo or pulling a trailer. Allow a greater distance for braking.
- Always place the transmission in PARK before getting out of the vehicle.
- Always stop the engine before refueling. Remove flammable material containers from the box before filling them with fuel. Make sure the refueling area is well ventilated and free of any source of flame or sparks. Gasoline is extremely flammable. See page 18 for fuel safety warnings.
- Always remove the ignition key when the vehicle is not in use to prevent unauthorized use by someone under the age of 16 or without a driver's license and proper training, or accidental starting.

**FOR MORE INFORMATION ABOUT SAFETY, call POLARIS at 1-800-342-3764.**

## Equipment Modifications

Do not install any non-POLARIS-approved accessory or modify the vehicle for the purpose of increasing speed or power. Any modifications or installation of non-POLARIS-approved accessories could create a substantial safety hazard and increase the risk of bodily injury.

The warranty on your POLARIS vehicle will be terminated if any non-POLARIS-approved equipment and/or modifications have been added to the vehicle that increase speed or power.

The addition of certain accessories, including (but not limited to) mowers, blades, tires, sprayers, or large racks, may change the handling characteristics of the vehicle. Use only POLARIS-approved accessories, and familiarize yourself with their function and effect on the vehicle.

# SAFETY

## Operator Safety

### **⚠ WARNING**

Failure to operate the *RANGER* properly can result in a collision, loss of control, accident or rollover, which may result in serious injury or death. Heed all safety warnings outlined in this section of the owner's manual. See the OPERATION section of the owner's manual for proper operating procedures.

### Age Restrictions

This vehicle is an ADULT VEHICLE ONLY. NEVER operate this vehicle if you are under age 16 and NEVER operate without a valid driver's license.

Never operate with a passenger under the age of 12. All riders must be able to sit with backs against the seat, both feet flat on the floor and both hands on the steering wheel (if driving) or on a passenger hand hold.



### Operating Without Instruction

Operating this vehicle without proper instruction increases the risk of an accident. The operator must understand how to operate the vehicle properly in different situations and on different types of terrain.

All operators should review the safety DVD provided with this vehicle and take a ROHVA training course ([www.rohva.org](http://www.rohva.org)).

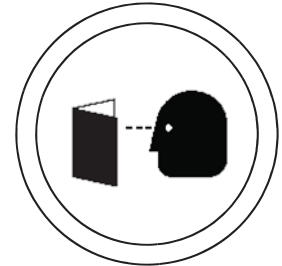

### Using Alcohol or Drugs

Operating the vehicle after consuming alcohol or drugs could adversely affect operator judgment, reaction time, balance and perception.

Never drink alcohol or use drugs or medications before or while operating this vehicle.



### Seat Belts

Riding in this vehicle without wearing the seat belt increases the risk of serious injury in the event of rollover, loss of control, other accident or sudden stop. Seat belts may reduce the severity of injury in these circumstances.

All riders *must* wear seat belts at all times.

### Protective Apparel

Riding in this vehicle without wearing an approved helmet and protective eyewear increases the risk of a serious injuries in the event of an accident.

Operator and all passengers *must* always wear an approved helmet that fits properly and eye protection (goggles or face shield).

## Operator Safety

### Cab Nets

Riding in this vehicle without using the cab nets (or doors, if equipped) increases the risk of serious injury or death in the event of an accident or rollover. Always use the cab nets (or doors) while riding in this vehicle.

*Always keep hands and feet inside the vehicle at all times.*

### Failure to Inspect Before Operating

Failure to inspect and verify that the vehicle is in safe operating condition before operating increases the risk of an accident. Always perform the pre-ride inspection before each use of your *RANGER* to make sure it's in safe operating condition. See page 29.

Always follow all inspection and maintenance procedures and schedules described in this owner's manual. See page 52.

### Operating With a Load on the Vehicle

The weight of both cargo and passengers impacts vehicle operation. For your safety and the safety of others, carefully consider how your vehicle is loaded and how to safely operate the vehicle. Follow the instructions in this manual for loading, tire pressure, gear selection and speed.

- **Do not exceed vehicle weight capacities.** The vehicle's maximum weight capacity is listed in the specifications section of this manual and on a label on the vehicle. When more passenger weight is added, cargo weight may need to be reduced accordingly.
- The recommended tire pressures are listed in the specifications section of this manual and on a label on the vehicle.

**Always follow these guidelines:**

Under ANY of these conditions:	Do ALL of these steps:
Passenger and/or cargo exceeds half the maximum weight capacity	<ol style="list-style-type: none"> <li>1. Slow down.</li> <li>2. Verify tire pressure.</li> <li>3. Use extra caution when operating.</li> </ol>
Operating in rough terrain	
Operating over obstacles	
Climbing an incline	
Towing	

# **SAFETY**

## **Operator Safety**

### **Handling Gasoline**

Gasoline is highly flammable and explosive under certain conditions.

- Always exercise extreme caution whenever handling gasoline.
- Always turn off the engine when refueling.
- Always refuel outdoors or in a well ventilated area free of any source of flame or sparks.
- Always use an approved gasoline container to store fuel and remove the container from the vehicle before filling to avoid fuel ignition due to electrical static discharge.
- Do not smoke or allow open flames or sparks in or near the area where refueling is performed or where gasoline is stored.
- Do not overfill the tank. Do not fill the tank neck.
- If gasoline spills on your skin or clothing, immediately wash it off with soap and water and change clothing.
- Turn the fuel valve off whenever the vehicle is stored or parked.

### **Exposure to Exhaust**

Engine exhaust fumes are poisonous and can cause loss of consciousness or death in a short time. Never start the engine or let it run in an enclosed area.

The engine exhaust from this product contains chemicals known to cause cancer, birth defects or other reproductive harm. Operate this vehicle only outdoors or in well-ventilated areas.

### **Operating a Damaged Vehicle**

Operating a damaged vehicle can result in an accident. After any rollover or other accident, have a qualified service dealer inspect the entire machine for possible damage, including (but not limited to) seat belts, rollover protection devices, brakes, throttle and steering systems.

### **Operating at Excessive Speeds**

Operating this vehicle at excessive speeds increases the operator's risk of losing control. Always operate at a speed that's appropriate for the terrain, the visibility and operating conditions, your skills and experience and your passengers' skills and experience.

### **Operating on Pavement**

This vehicle's tires are designed for off-road use only, not for use on pavement. Operating this vehicle on paved surfaces (including sidewalks, paths, parking lots and driveways) may adversely affect the handling of the vehicle and may increase the risk of loss of control and accident or rollover. Avoid operating the vehicle on pavement. If it's unavoidable, travel slowly, travel short distances and avoid sudden turns or stops.

## Operator Safety

### Operating on Public Roads

Operating this vehicle on public streets, roads or highways could result in a collision with another vehicle. Never operate this vehicle on any public street, road or highway, including dirt and gravel roads (unless designated for off-highway use). In some areas it's unlawful to operate this vehicle on public streets, roads and highways.

### Turning Improperly

Turning improperly could cause loss of traction, loss of control, accident or rollover. Always follow proper procedures for turning as described in this owner's manual. Never turn abruptly or at sharp angles. Never turn at high speeds. Practice turning at slow speeds before attempting to turn at faster speeds.

### Jumps and Stunts

Attempting wheelies, jumps and other stunts increases the risk of an accident or rollover. Never attempt wheelies, jumps, or other stunts. Avoid exhibition driving.

### Operating in Unfamiliar Terrain

Failure to use extra caution when operating on unfamiliar terrain could result in an accident or rollover. Unfamiliar terrain may contain hidden rocks, bumps, or holes that could cause loss of control or rollover. Travel slowly and use extra caution when operating on unfamiliar terrain. Always be alert to changing terrain conditions.

### Improper Hill Climbing

Climbing hills improperly can cause loss of control or vehicle rollover. Always follow proper procedures for climbing hills as described in this owner's manual. See page 35.

### Descending Hills Improperly

Improperly descending a hill could cause loss of control or rollover. Always follow proper procedures for traveling down hills as described in this owner's manual. See page 35.

### Stalling While Climbing a Hill

Stalling or rolling backwards while climbing a hill could cause a rollover. Always maintain a steady speed when climbing a hill.

*If all forward speed is lost:*

- Apply the brakes.
- Place the transmission in reverse and slowly allow the vehicle to roll straight downhill while applying light brake pressure to control speed.

*If you begin rolling downhill:*

- Never apply engine power.
- Apply the brakes gradually until the vehicle is fully stopped.
- Place the transmission in reverse and slowly allow the vehicle to roll straight downhill while applying light brake pressure to control speed.

# **SAFETY**

## **Operator Safety**

### **Improper Tire Maintenance**

Operating this vehicle with improper tires or with improper or uneven tire pressure could cause loss of control or accident.

Always use the size and type of tires specified for your vehicle. Always maintain proper tire pressure as described in the owner's manual and on safety labels.

### **Operating on Slippery Terrain**

Failure to use extra caution when operating on excessively rough, slippery or loose terrain could cause loss of traction, loss of control, accident or rollover. Do not operate on excessively slippery surfaces. Always slow down and use additional caution when operating on slippery surfaces.

Skidding or sliding due to loss of traction can cause loss of control or rollover (if tires regain traction unexpectedly). Always follow proper procedures for operating on slippery surfaces as described in this owner's manual. See page 34.

### **Operating on Frozen Bodies of Water**

Severe injury or death can result if the vehicle and/or the operator fall through the ice. Never operate the vehicle on a frozen body of water unless you have first verified that the ice is sufficiently thick to support the weight and moving force of the vehicle, you and your passengers, and your cargo, together with any other vehicles in your party.

Always check with local authorities and residents to confirm ice conditions and thickness over your entire route. Vehicle operators assume all risk associated with ice conditions on frozen bodies of water.

### **Unauthorized Use of the Vehicle**

Leaving the keys in the ignition can lead to unauthorized use of the vehicle by someone under the age of 16, without a drivers license, or without proper training. This could result in an accident or rollover. Always remove the ignition key when the vehicle is not in use.

### **Hot Exhaust Systems**

Exhaust system components are very hot during and after use of the vehicle. Hot components can cause burns and fire. Do not touch hot exhaust system components. Always keep combustible materials away from the exhaust system. Use caution when traveling through tall grass, especially dry grass, to avoid debris build-up around the exhaust system.

# FEATURES AND CONTROLS

## Component Locations

Your vehicle is equipped with cab nets on both sides of the vehicle. Cab nets (or doors, if equipped) must be used by both operator and passengers at all times. The vehicle illustrated below is shown without cab nets only to allow component identification. Always use the cab nets (or doors).

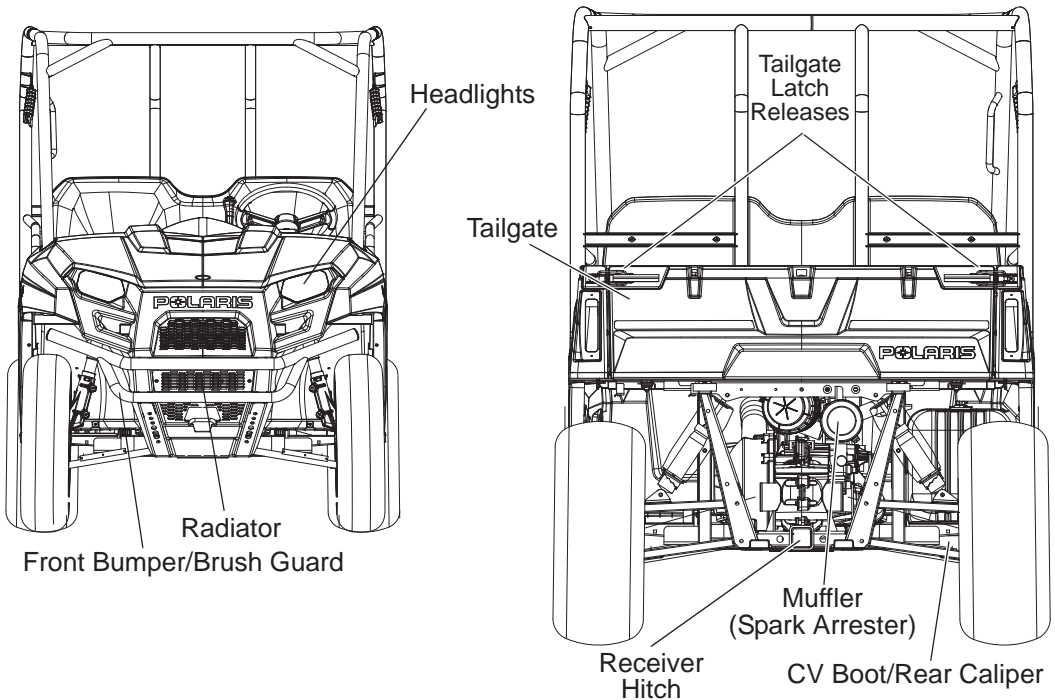
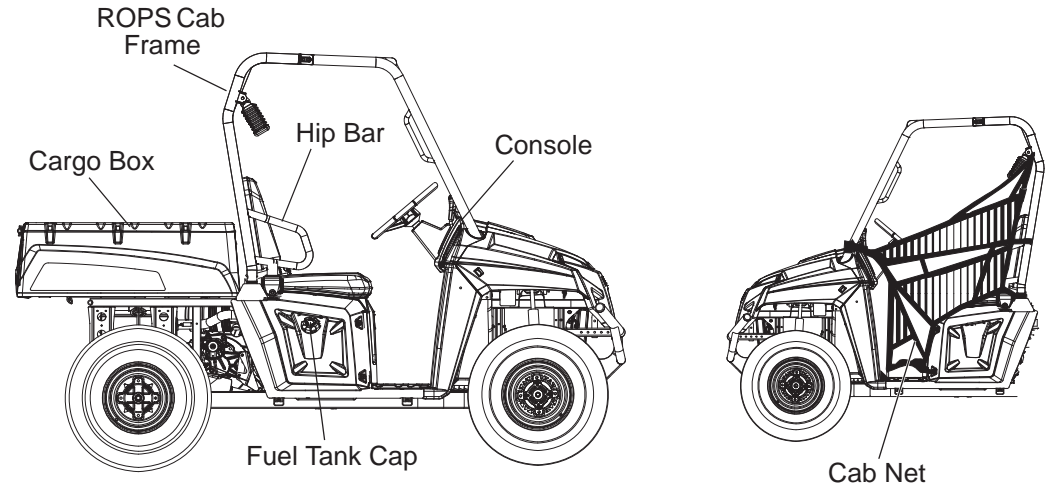

# FEATURES AND CONTROLS

## Component Locations

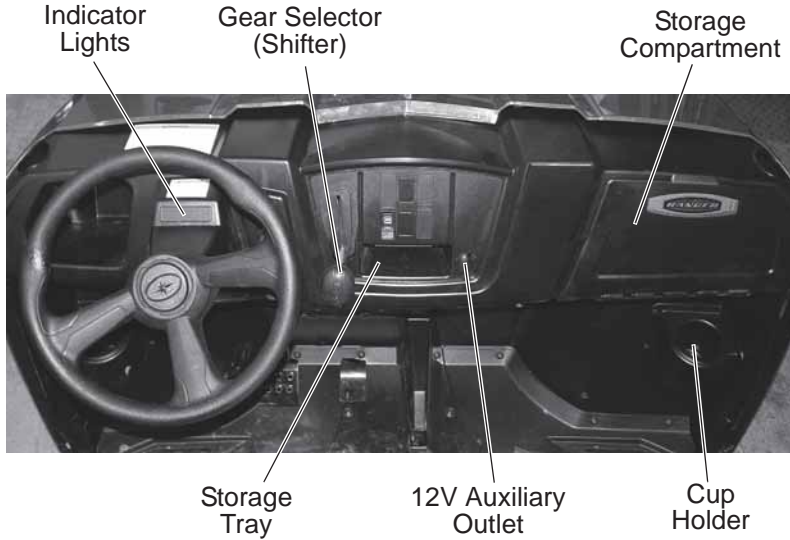

### Auxiliary Outlet

The 12-volt receptacles have spade connections on the back that may be used to power an auxiliary light or other optional accessories or lights. The connections are behind the console, under the hood.

### Indicator Lights

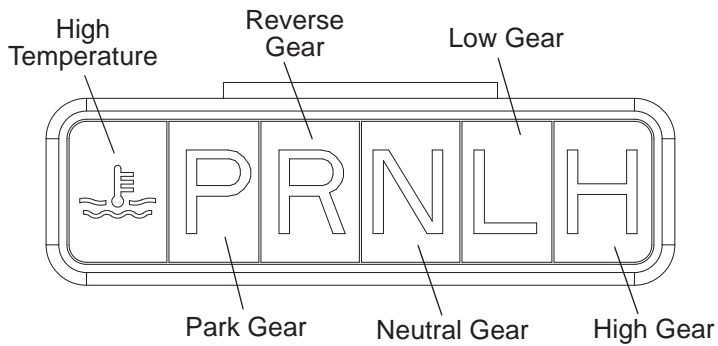



## Component Locations

### Gear Selector

H: High Gear

L: Low Gear

N: Neutral

R: Reverse

P: Park

Low gear is the primary driving range for the *RANGER*. High gear is intended for use on hard-packed surfaces with light loads. Whenever the vehicle is left unattended, always place the transmission in **PARK**.

To change gears, stop the vehicle, and with the engine idling, move the lever to the desired gear. Do not attempt to shift gears with engine speed above idle or while the vehicle is moving.

**Tip:** Maintaining shift linkage adjustment is important to assure proper transmission function. See your dealer if you experience any shifting problems.

**NOTICE:** Shifting gears with the engine speed above idle or while the vehicle is moving could cause transmission damage. Always shift when the vehicle is stationary and the engine is at idle.



### Using Low Range

Always shift into low gear for any of the following conditions.

- Operating in rough terrain or over obstacles
- Loading the vehicle onto a trailer
- Towing heavy loads

### Brake Pedal

Depress the brake pedal to slow or stop the vehicle. Apply the brakes while starting the engine.

### Throttle Pedal

Push the pedal down to increase engine speed. Spring pressure returns the pedal to the rest position when released. Always check that the throttle pedal returns normally before starting the engine. Make sure there's adequate throttle pedal freeplay. See page 70 for throttle pedal adjustment procedures.

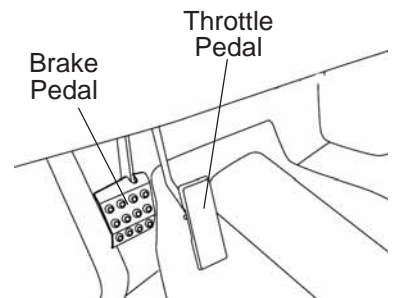

# FEATURES AND CONTROLS

## Switches

### Ignition Switch/Light Switch

The ignition switch is a four-position, key-operated switch. The key can be removed from the switch when it is in the OFF position.



<b>OFF</b>	The engine is off. Electrical circuits are off, except Acc, 12V.
<b>LIGHTS ON</b>	Lights are on. Electrical circuits are on. Electrical equipment can be used.
<b>LIGHTS OFF</b>	Lights are off. Electrical circuits are on. Electrical equipment can be used.
<b>START</b>	Turn the key to the START position to engage the electric starter. Turn the key to the LIGHTS ON position after starting the engine.

### AWD/Differential Lock Switch

The AWD/Differential Switch has three positions: All Wheel Drive (AWD), Differential Lock/Two Wheel Drive (2WD) and Off (1WD/Turf Mode).

Press the top of the switch to engage All Wheel Drive (AWD). See page 41 for AWD operating instructions.

Move the switch to the center position to lock the differential and operate in two wheel drive (2WD). Press the bottom of the switch to unlock the differential and allow the rear drive wheels to operate independently (1WD). This mode of operation is well suited to turf driving or when active traction is not needed.

See page 40 for Differential Lock operating instructions.

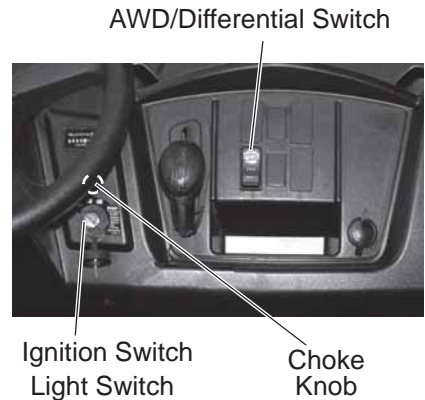

# FEATURES AND CONTROLS

## Trailer Hitch Bracket

This vehicle is equipped with a receiver hitch bracket for a trailer hitch. Trailer towing equipment is not supplied with this vehicle.

To avoid injury and property damage, always heed the warnings and towing capacities outlined on pages 37-38.

## Fuel Cap

The fuel tank filler cap is located on the right-hand side of the vehicle near the passenger seat. When refueling, always use either leaded or unleaded gasoline with a minimum pump octane number of 87 R+M/2 octane. *Do not use fuel with ethanol content greater than 10 percent, such as E-85 fuel.*



## Roll-Over Protection System (ROPS)

The Rollover Protective Structure (ROPS) on this vehicle meets OSHA 1928.53 rollover performance requirements. Always have your authorized POLARIS dealer thoroughly inspect the ROPS if it ever becomes damaged in any way.

*No device can assure occupant protection in the event of a rollover.* Always follow all safe operating practices outlined in this manual to avoid vehicle rollover.

Vehicle rollover could cause severe injury or death. Always avoid operating in a manner that could result in vehicle rollover.

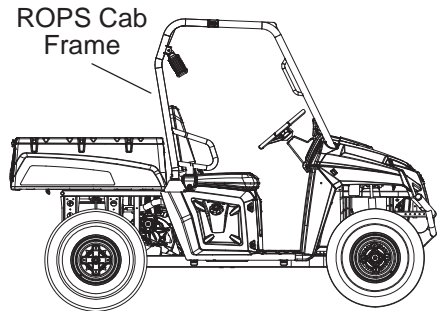

# FEATURES AND CONTROLS

## Seat Belts

This POLARIS vehicle is equipped with three-point lap and diagonal seat belts for the operator and passenger. Always make sure the seat belts are secured for all riders before operating.

The center of the seat is NOT equipped with a seat belt. Never allow a passenger to ride between the operator and passenger seats.

**WARNING!** Falling from a moving vehicle could result in serious injury or death. Always fasten your seat belt securely before operating or riding in the *RANGER*.

To wear the seat belt properly, follow this procedure:

1. For 3-point belts, pull the seat belt latch downward and across your chest toward the buckle at the inner edge of the seat. The belt should fit snugly across your hips and diagonally across your chest. Make sure the belt is not twisted.
2. Push the latch plate into the buckle until it clicks.
3. Release the strap, it will self tighten.
4. To release the seat belt, press the square red button in the buckle's center.

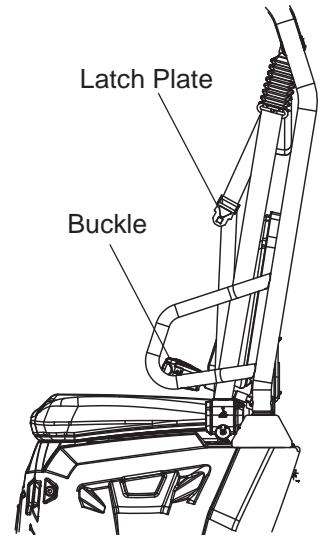

## Seat Belt Inspection

Inspect all seat belts for proper operation before each use of the vehicle.

1. Push the latch plate into the buckle until it clicks. The latch plate must slide smoothly into the buckle. A click indicates that it's securely latched.
2. Push the red release latch in the middle of the buckle to make sure it releases freely.
3. Pull each seat belt completely out and inspect the full length for any damage, including cuts, wear, fraying or stiffness. If any damage is found, or if the seat belt does not operate properly, have the seat belt system checked and/or replaced by an authorized POLARIS dealer.
4. To clean dirt or debris from the seat belts, sponge the straps with mild soap and water. Do not use bleach, dye or household detergents.

# FEATURES AND CONTROLS

## Seat Removal

Pull up on the front of the seat and slide it toward the front of the vehicle.

Install the seat by sliding the tabs into the rear of the seat base. Push down firmly on the front of the seat until the pins are fully seated into the grommets.

## Cab Nets

Riding in this vehicle without using the cab nets (or doors, if equipped) increases the risk of serious injury or death in the event of an accident or rollover. Cab nets (or doors) must be used by both operator and passengers at all times. Make sure all latches are secure before operating the vehicle.

Always inspect cab nets and latches for tightness, wear and damage before each use of the vehicle. Use the strap adjusters to tighten any loose straps. Promptly replace worn or damaged cab nets and latches with new cab nets and latches. Please see your authorized POLARIS dealer.

## Securing a Net

1. After entering the vehicle, insert the lower net rod into the net mount on the floor. Make sure the ball at the end of the rod is properly secured in the slot at the base of the mount.
2. Connect the latch at the top edge of the net to the receiver latch mounted on the front frame.

## Opening a Net

1. To exit the vehicle, release the top front latch.
2. Rotate the net rearward and slide the lower net rod out of the mount to remove it.
3. Allow the net to hang freely outside the vehicle while dismounting.

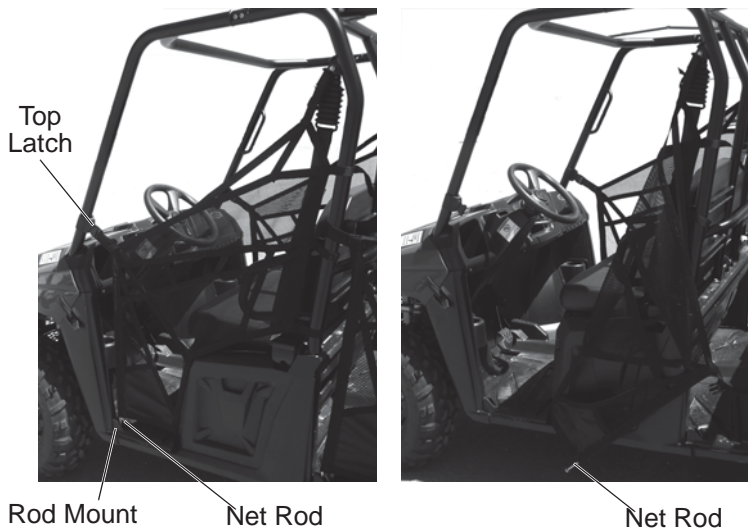

# OPERATION

## WARNING

Failure to operate the vehicle properly can result in a collision, loss of control, accident or rollover, which may result in serious injury or death. Read and understand all safety warnings outlined in the safety section of this owner's manual.

## Break-In Period

The break-in period for your new POLARIS *RANGER* is the first twenty hours of operation, or the time it takes to use the first two tanks full of gasoline. No single action on your part is as important as a proper break-in period. Careful treatment of a new engine will result in more efficient performance and longer life for the engine. Perform the following procedures carefully.

**NOTICE:** Excessive heat build-up during the first three hours of operation will damage close-fitted engine parts. Do not operate at full throttle or high speeds for extended periods during the first three hours of use.

## Engine and Drivetrain Break-in

1. Fill the fuel tank with gasoline. Heed the gasoline warnings on page 18.
2. Check the oil level. See page 56. Add the recommended oil as needed to maintain the oil level between the safe and add marks.
3. Drive slowly at first. Select an open area that allows room to familiarize yourself with vehicle operation and handling.
4. Vary throttle positions. Do not operate at sustained idle.
5. Perform regular checks on fluid levels, controls and areas outlined on the daily pre-ride inspection checklist. See page 29.
6. Pull only light loads.
7. Check fluid levels of transmission and all gearcases after the first 25 hours of operation and every 100 hours thereafter.
8. During the break-in period, change both the oil and the filter at 25 hours.

## PVT Break-in (Clutches/Belt)

A proper break-in of the clutches and drive belt will ensure a longer life and better performance. Break in the clutches and belt by operating at slower speeds during the break-in period as recommended. Pull only light loads. Avoid aggressive acceleration and high speed operation during the break-in period.

If a belt fails, always clean any debris from the duct and from the engine compartment.

## Pre-Ride Inspection

Failure to inspect and verify that the vehicle is in safe operating condition before operating increases the risk of an accident. Always inspect the vehicle before each use to make sure it's in safe operating condition.

Item	Remarks	Page
Brake system/pedal travel	Ensure proper operation	23 71
Brake fluid	Ensure proper level	71
Park gear	Ensure vehicle does not roll when in PARK. Ensure PARK light illuminates.	-
Front suspension	Inspect, lubricate if necessary	55
Rear suspension	Inspect, lubricate if necessary	55
Steering	Ensure free operation	72
Tires	Inspect condition and pressure	12 73
Wheels/fasteners	Inspect, ensure fastener tightness	73
Frame nuts, bolts, fasteners	Inspect, ensure tightness	-
Fuel and oil	Ensure proper levels	25 56
Coolant level	Ensure proper level	63
Coolant hoses	Inspect for leaks	-
Throttle	Ensure proper operation	70
Indicator lights/switches	Ensure operation	22 24
Air filter, pre-filter	Inspect, clean	67
Air box sediment tube	Drain deposits whenever visible	67
Headlamp	Check operation, apply POLARIS dielectric grease when lamp is replaced	75
Brake light/tail lamp	Check operation, apply POLARIS dielectric grease when lamp is replaced	76
Seat Belts	Check length of belt for damage, check latches for proper operation	26
Cab nets (or doors)	Check for wear or damage, ensure proper installation	27

# OPERATION

## Starting the Engine

1. Always start the engine outdoors or in a well-ventilated area.
2. Turn the fuel valve on.
3. Sit in the driver's seat and fasten the seat belt. Secure the cab nets (or doors).
4. Apply the brakes. Place the transmission in PARK.
5. Do not use the choke if starting a warm engine. Excessive use of the choke can cause spark plugs to become wet fouled.
6. If the engine is cold, pull the choke knob out until it stops.
7. Turn the ignition key to START. Engage the starter for a maximum of five seconds. Release the key when the engine starts. Turn the key to the LIGHTS ON position before driving.
8. Do not press the throttle pedal while starting the engine. If the engine does not start within five seconds, release the ignition switch and wait five seconds. Repeat steps 7 and 8 until the engine starts.
9. If a warm engine has cooled to a point where it does not readily start, intermittent use of the choke (half way out) may be necessary. If the engine is over-choked when warm, depress the throttle pedal fully while cranking to aid in starting. Release the throttle pedal *immediately* after the engine starts. If the engine does not start and all conditions are favorable, change the spark plug and try again.
10. After the engine starts, push the choke knob in half way.
11. Vary the engine RPM slightly with the throttle to aid in warm up until the engine idles smoothly.
12. Push the choke knob in.

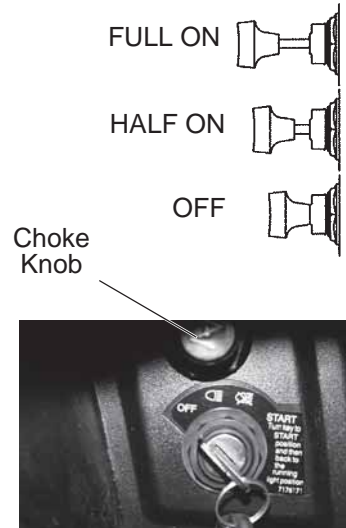

**NOTICE:** Operating the vehicle immediately after starting could cause engine damage. Allow the engine to warm up for several minutes before operating the vehicle.



## Stopping the Engine

1. Release the throttle pedal completely and brake to a complete stop.
2. Place the transmission in PARK.
3. Turn the engine off.

**WARNING!** A rolling vehicle can cause serious injury. Always place the transmission in PARK when stopping the engine.

## Braking

1. Release the throttle pedal completely.
2. Press on the brake pedal evenly and firmly.
3. Practice starting and stopping (using the brakes) until you're familiar with the controls.

**Tip:** When the throttle pedal is released completely and the engine speed drops near an idle, the vehicle has no engine braking.

## Driving Procedure

1. Wear a helmet, eye protection, gloves, long-sleeve shirt, long pants and over-the-ankle boots.
2. Sit in the driver's seat and fasten the seat belt.
3. Start the engine and allow it to warm up.
4. Always use the cab nets (or doors) while riding in this vehicle.
5. Apply the service brakes and shift the transmission into gear.
6. Check your surroundings and determine your path of travel.
7. Keeping both hands on the steering wheel, slowly release the brakes and depress the throttle with your right foot to begin driving.
8. Drive slowly. Practice maneuvering and using the throttle and brakes on level surfaces.
9. Do not carry a passenger until you have at least two hours of driving experience with this vehicle. Never carry more than one passenger in this vehicle. Never allow a passenger to ride in the cargo box.

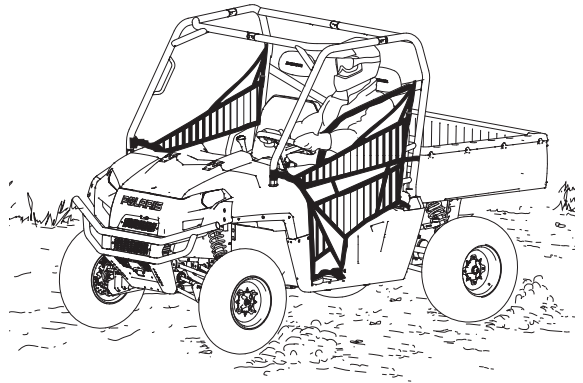

# **OPERATION**

## **Driving with a Passenger**

1. Perform the pre-ride inspection. See page 29.
2. Make sure any passenger is at least 12 years of age and tall enough to comfortably and safely sit in a passenger seat with the seat belt secured, put both feet on the floor and grasp the hand hold.
3. Make sure all passengers are wearing helmet, eye protection, gloves, long-sleeve shirt, long pants and over-the-ankle boots.
4. Make sure your passenger secures the seat belt.
5. Make sure all cab nets (or doors) are properly secured.
6. Never carry more than one passenger in this vehicle. Never allow a passenger to ride in the cargo box. Allow a passenger to ride only in a passenger seat.
7. Slow down. Always travel at a speed appropriate for your skills, your passenger's skills, and operating conditions. Avoid unexpected or aggressive maneuvers that could cause discomfort or injury to a passenger.
8. Vehicle handling may change with a passenger and/or cargo on board. Allow more time and distance for braking.
9. Always follow all operating guidelines as outlined on safety labels and in this manual.

## **Parking the Vehicle**

1. Apply the brakes. Stop the vehicle on a level surface.
2. When parking inside a garage or other structure, be sure that the structure is well ventilated and that the vehicle is not close to any source of flame or sparks, including any appliance with pilot lights.
3. Place the transmission in PARK.
4. Turn the engine off.
5. Remove the ignition switch key to prevent unauthorized use.

## Driving in Reverse

Follow these precautions when operating in reverse:

1. Always check for obstacles or people behind the vehicle. Always inspect left and right fields of vision before backing.
2. Always avoid backing downhill.
3. Back slowly.
4. Apply the brakes *lightly* for stopping.
5. Avoid turning at sharp angles.
6. Never open the throttle suddenly.

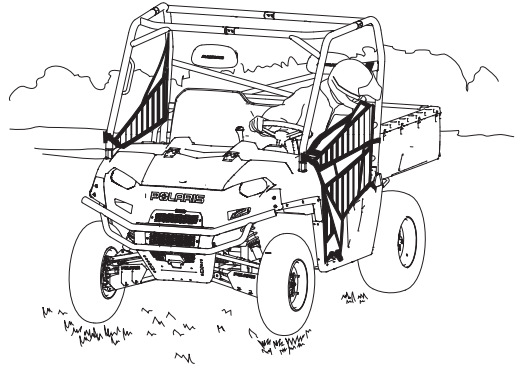

## Driving Over Obstacles

Follow these precautions when operating over obstacles:

1. Always check for obstacles before operating in a new area.
2. Look ahead and learn to read the terrain. Be constantly alert for hazards such as logs, rocks and low hanging branches.
3. Travel slowly and use extra caution when operating on unfamiliar terrain. Not all obstacles are immediately visible.
4. Avoid operating over large obstacles such as large rocks and fallen trees. If unavoidable, use extreme caution and operate slowly.
5. Always have all passengers dismount and move away from the vehicle before operating over an obstacle that could cause a rollover.

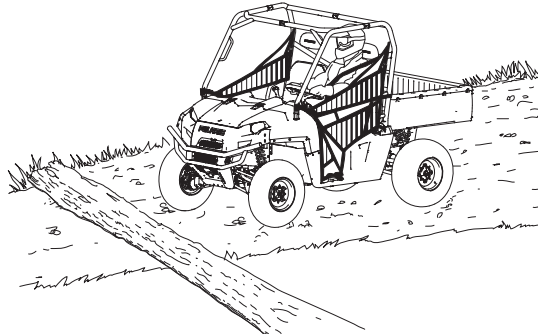

# OPERATION

## Driving On Slippery Surfaces

### ⚠ WARNING

Skidding or sliding can cause loss of control or rollover (if tires regain traction unexpectedly). When operating on slippery surfaces such as ice or loose gravel, reduce speed and use extra caution to reduce the chance of skidding or sliding out of control. Do not operate on excessively slippery surfaces.

Whenever riding on slippery surfaces such as wet trails or loose gravel, or during freezing weather, follow these precautions:

1. Do not operate on excessively rough, slippery or loose terrain.
2. Slow down before entering slippery areas.
3. Maintain a high level of alertness, reading the trail and avoiding quick, sharp turns, which can cause skids.
4. Engage all-wheel drive before wheels begin to lose traction.

**NOTICE:** Severe damage to the drive train may occur if the AWD is engaged while the wheels are spinning. Always allow the wheels to stop spinning before engaging AWD.

5. Correct a skid by turning the steering wheel in the direction of the skid. *Never apply the brakes during a skid.*

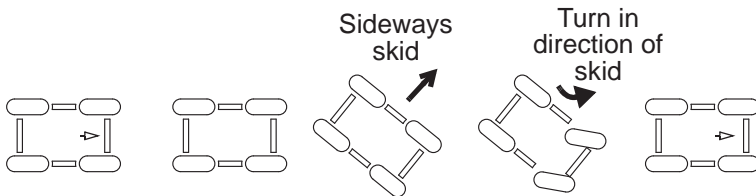

## Driving Uphill

Whenever traveling uphill, follow these precautions:

1. Always travel straight uphill.
2. Avoid excessively steep hills.
3. Keep both feet on the floor.
4. Always check the terrain carefully before ascending any hill. Never climb hills with excessively slippery or loose surfaces.
5. Proceed at a steady rate of speed and throttle opening. Never open the throttle suddenly.
6. Never go over the crest of a hill at high speed. An obstacle, a sharp drop, or another vehicle or person could be on the other side of the hill.

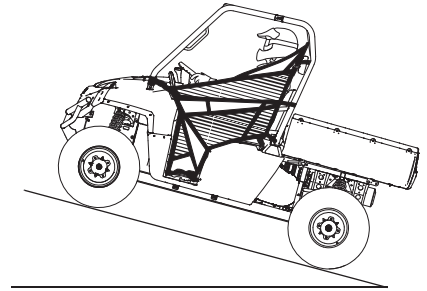

## Driving on a Sidehill (Sidehilling)

Driving on a sidehill is not recommended. Improper procedure could cause loss of control or rollover. Avoid crossing the side of any hill unless absolutely necessary.

If crossing a sidehill is *unavoidable*, follow these precautions:

1. Slow down.
2. Exercise extreme caution.
3. Avoid crossing the side of a steep hill.

## Driving Downhill

When driving downhill, follow these precautions:

1. Avoid excessively steep hills.
2. Drive straight downhill. Avoid descending a hill at an angle, which would cause the vehicle to lean sharply to one side. Travel straight downhill when possible.
3. Slow down.
4. Apply the brakes *slightly* to aid in slowing.

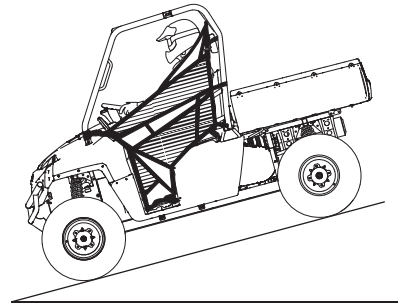

# OPERATION

## Parking on an Incline

Avoid parking on an incline if possible. If it's unavoidable, follow these precautions:

1. Apply the brakes.
2. Place the transmission in PARK.
3. Turn the engine off.
4. Block the rear wheels on the downhill side.

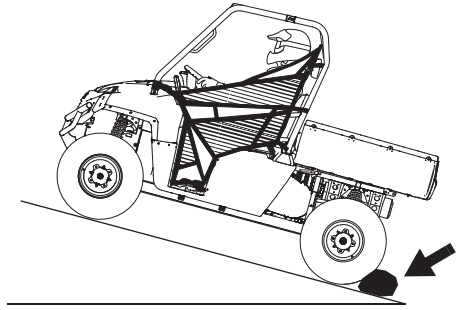

## Driving Through Water

Your POLARIS *RANGER* can operate through water up to a maximum recommended depth equal to the floorboards.

**NOTICE:** Immersion can result in major damage if the vehicle isn't serviced correctly and promptly. After immersion, always take the vehicle to your dealer service. Do not start the engine! If it's impossible to bring the vehicle to your dealer before starting the engine, perform the service outlined on page 66, and take the vehicle to your dealer at the first opportunity.

Follow these procedures when operating through water:

1. Determine water depths and current before entering water.
2. Choose a crossing where both banks have gradual inclines.
3. Proceed slowly, avoiding rocks and obstacles.
4. Avoid operating through deep or fast-flowing water.

**WARNING!** The large tires on your *RANGER* may cause the vehicle to float in deep or fast-flowing water, which could result in loss of control and lead to serious injury or death. Never cross deep or fast-flowing water with your *RANGER*.

5. After leaving water, always dry the brakes by applying light pressure to the pedal repeatedly until braking action is normal.

**NOTICE:** After running your vehicle in water, it's critical that you perform the services outlined in the Periodic Maintenance Chart beginning on page 52. Give special attention to engine oil, transmission oil, front and rear gearcases (if equipped) and all grease fittings.

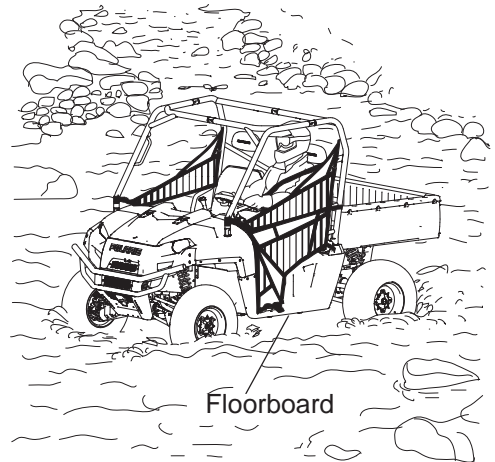

## Hauling Cargo

### **⚠ WARNING**

Hauling cargo improperly can alter vehicle handling and may cause loss of control or brake instability, which can result in serious injury or death. Always follow these precautions when hauling cargo:

Never exceed the maximum weight capacity of the vehicle. When determining the weight you are adding to the vehicle, include the weight of the operator, passenger, accessories, loads in the rack or box and the load on the trailer tongue. The combined weight of these items must not exceed the maximum weight capacity.

**REDUCE SPEED AND ALLOW GREATER DISTANCES FOR BRAKING WHEN HAULING CARGO.**

Always load the cargo box with the load as far forward and as low as possible.

When operating over rough or hilly terrain, reduce speed and cargo to maintain stable driving conditions.

Always operate the vehicle with extreme care when hauling or towing loads.

Slow down and drive in the lowest gear available.

**SECURE ALL LOADS BEFORE OPERATING.** Unsecured loads can create unstable operating conditions, which could result in loss of control of the vehicle.

**OPERATE ONLY WITH STABLE AND SAFELY ARRANGED LOADS.** When handling off-centered loads that cannot be centered, securely fasten the load and operate with extra caution. Always attach the tow load to the hitch point designated for your vehicle.

**HEAVY LOADS CAN CAUSE BRAKING AND CONTROL PROBLEMS.** Use extreme caution when applying brakes with a loaded vehicle. Avoid terrain or situations that may require backing downhill.

**USE EXTREME CAUTION** when operating with loads that extend over the rack sides. Stability and maneuverability may be adversely affected, causing a rollover.

**DO NOT TRAVEL FASTER THAN THE RECOMMENDED SPEEDS.** Vehicle should never exceed 10 MPH (16 km/h) while towing a load on a level grass surface. Vehicle speed should never exceed 5 MPH (8 km/h) when towing loads in rough terrain, while cornering, or while ascending or descending a hill.

The *RANGER* has been designed to carry or tow specific capacities. Always read and understand the load distribution warnings listed on the warning labels. The total load (operator, passenger, accessories, cargo and weight on hitch) must not exceed the maximum weight capacity of the vehicle. Never exceed the following capacities.

Model	Maximum Capacities (Level Ground)	Cargo Box
<i>RANGER</i> 400	1000 lbs. (454 kg)	500 lbs. (227 kg)

**WARNING!** Driving with passengers in the cargo box can result in severe injury or death. Never allow passengers to ride in the cargo box. A passenger must always ride in the cab with seat belt fastened securely.

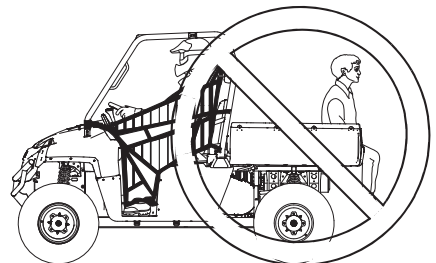

# OPERATION

## Towing Loads

Towing improperly can alter vehicle handling and may cause loss of control or brake instability. Always follow these precautions when towing:

1. Never load more than 150 lbs. (68.1 kg) tongue weight on the towing bracket.
2. Always shift to low gear for towing.
3. When towing a disabled *RANGER* vehicle, place the disabled vehicle's transmission in neutral. Do not operate the vehicle faster than 10 MPH (16 km/h) when towing.
4. Do not operate the vehicle faster than 10 MPH (16 km/h) when towing. See page 37. Towing a trailer increases braking distance.
5. Do not tow more than the recommended weight for the vehicle. See the towing capacity chart below and the specifications charts beginning on page 86.
6. Attach a trailer to the trailer hitch bracket only. Do not attach a trailer to any other location or you may lose control of the vehicle.
7. Never tow a trailer on a grade steeper than 15°.

Model	Total Towed Load Weight (Level Ground)	Total Towed Load Weight (15° grade)	Total Hitch Vertical Weight	Maximum Towing Speed
RANGER 400	1250 lbs. (567 kg)	850 lbs. (386 kg)	150 lbs. (68.1 kg)	10 MPH (16 km/h)

### Belt Life

To extend belt life, use the lowest gear possible when hauling or towing heavy cargo.



## Dumping the Cargo Box

1. Select a level site to dump the cargo box. Do not attempt to dump or unload the vehicle while parked on an incline.
2. Apply the brakes.
3. Place the transmission in PARK. Dismount the vehicle.
4. Ensure that the cargo is positioned evenly or toward the front of the cargo box.
5. Release the tailgate latches.

**WARNING!** If the weight distribution on the box is located toward the rear of the box when the release lever is pulled forward, the box may dump unexpectedly and cause serious injury to the operator or bystanders. Never operate the dump lever without ensuring that the load is positioned evenly or at the front of the box.

6. Stand clear and pull up on the cargo box release lever. Lift the front of the cargo box to dump the cargo.
7. Lower the cargo box and push down securely to latch.
8. Close the tailgate and secure both tailgate latches.

**WARNING!** Operating the vehicle while the cargo box is raised could result in severe injury. The box could close unexpectedly and cause injury to the driver or passenger. The rear tires will also catch the rear of a raised box, damaging the vehicle and creating hazardous driving conditions. Never operate this vehicle with the cargo box in the raised position.

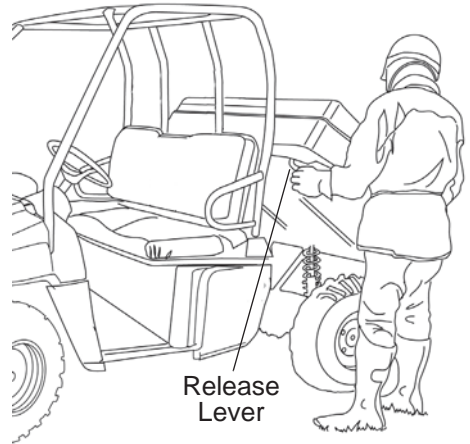

# OPERATION

## Differential Operation Modes

The 4X4 rear axle is equipped with a lockable differential that allows the operator to choose between an open differential or a closed differential.

### AWD

Press the top of the rocker switch to engage All Wheel Drive (AWD). When in AWD, the rear wheels rotate at the same speed. The front wheels also rotate at the same speed. See page 41 for AWD operating instructions.

### 2WD/Rear Differential Locked

Move the rocker switch to the center position to lock the differential and operate in two wheel drive (2WD). Locking the differential in slippery or low traction conditions helps improve traction. When the rear differential is locked, both rear wheels rotate at the same speed.

### OFF/Differential Unlocked

Press the bottom of the switch to unlock the differential and allow the rear drive wheels to operate independently (1WD). When the rear differential is unlocked, the rear wheels can rotate at different speeds. Unlock the differential to make maneuvering easier and minimize damage to turf.

**NOTICE:** Damage to the differential can occur if it is engaged while the vehicle is traveling at high speeds or while the rear wheels are spinning. Slow the vehicle to nearly stopped before engaging the differential.

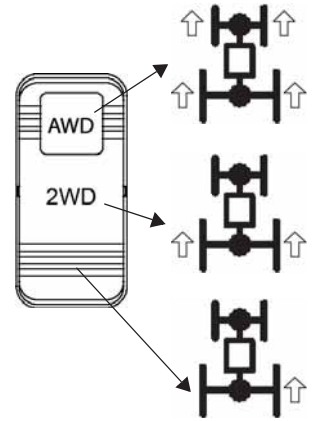

## All Wheel Drive (AWD)

The illuminated amber AWD switch indicates that the vehicle is in AWD. When the AWD switch is on, the front gearcase will automatically engage any time the rear wheels lose traction. When the rear wheels regain traction, the front gearcase will automatically disengage. There is no limit to the length of time the vehicle may remain in AWD.

**Tip:** The AWD switch may be turned on or off while the vehicle is moving.

Initially, the vehicle's electronic system will not enable the AWD until the engine RPM is below 3100. Once enabled, the AWD remains enabled until the AWD switch is turned off.

Engage the AWD before getting into conditions where front wheel drive may be needed. If the rear wheels are spinning, release the throttle before switching to AWD.

**NOTICE:** Switching to AWD while the rear wheels are spinning may cause severe drive shaft and clutch damage. Always switch to AWD while the rear wheels have traction or are at rest.

## Disengaging AWD

Under certain conditions, it may be possible for the front gearcase to remain locked unnecessarily. This condition causes increased steering effort and some vehicle speed restriction. If the front gearcase remains locked after following these instructions, return the vehicle to your dealer for service.

1. Stop the vehicle.
2. Operate in reverse for at least 10 feet (3 m).
3. Stop completely.
4. Shift into low gear and drive forward.

# WINCH GUIDE

These safety warnings and instructions apply if your vehicle came equipped with a winch or if you choose to add an accessory winch to your vehicle.

## **⚠ WARNING**

Improper winch use can result in SEVERE INJURY or DEATH. Always follow all winch instructions and warnings in this manual.

Your winch may have a cable made of either wire rope or specially designed synthetic rope. The term “winch cable” will be used for either unless noted otherwise.

## Winch Safety Precautions

1. Read all sections of this manual.
2. Never use alcohol or drugs before or while operating the winch.
3. Never allow children under 16 years of age to operate the winch.
4. Always wear eye protection and heavy gloves when operating the winch.
5. Always keep body, hair, clothing and jewelry clear of the winch cable, fairlead and hook when operating winch.
6. Never attempt to “jerk” a load attached to the winch with a moving vehicle. See the *Shock Loading* section on page 49.
7. Always keep the area around the vehicle, winch, winch cable and load clear of people (especially children) and distractions while operating the winch.
8. Always turn the vehicle ignition power OFF when it and the winch are not being used.
9. Always be sure that at least five (5) full turns of winch cable are wrapped around the winch drum at all times. The friction provided by this wrapped cable allows the drum to pull on the winch cable and move the load.
10. Always apply your vehicle’s park brake and/or park mechanism to hold the vehicle in place during winching. Use wheel chocks if needed.
11. Always align the vehicle and winch with the load directly in front of the vehicle as much as possible. Avoid winching with the winch cable at an angle to the winching vehicle’s centerline whenever possible.
12. If winching at an angle is unavoidable, follow these precautions:
  - A. Look at the winch drum occasionally. Never let the winch cable “stack” or accumulate at one end of the winch drum. Too much winch cable at one end of the winch drum can damage the winch and the winch cable.
  - B. If stacking occurs, stop winching. Follow step 15 on page 47 to feed and rewind the cable evenly before continuing the winch operation.

## Winch Safety Precautions

13. Never winch up or down at sharp angles. This can destabilize the winching vehicle and possibly cause it to move without warning.
14. Never attempt to winch loads that weigh more than the winch's rated capacity.
15. The winch motor may become hot during winch use. If you winch for more than 45 seconds, or if the winch stalls during operation, stop winching and permit the winch to cool down for 10 minutes before using it again.
16. Never touch, push, pull or straddle the winch cable while winching a load.
17. Never let the winch cable run through your hands, even if wearing heavy gloves.
18. Never release the clutch on the winch when the winch cable is under load.
19. Never use the winch for lifting or transporting people.
20. Never use the winch to hoist or suspend a vertical load.
21. Never immerse or submerge your winch in water. Take your winch to your dealer for service if this occurs.
22. Always inspect your winch and winch cable before each use.
23. Never winch the hook fully into the winch. This can cause damage to winch components.
24. Unplug the remote control from the vehicle when the winch is not in use to prevent inadvertent activation and use by unauthorized persons.
25. Never grease or oil the winch cable. This will cause the winch cable to collect debris that will shorten the life of the cable.



# WINCH GUIDE

## Winch Operation

Read the *Winch Safety Precautions* in the preceding pages before using your winch.

**Tip:** Consider practicing the operation and use of your winch before you actually need to use it in the field.

### **⚠ WARNING**

Improper winch use can result in SEVERE INJURY or DEATH. Always follow all winch instructions and warnings in this manual.

Each winching situation is unique.

- Take your time to think through the winching you are about to do.
  - Proceed slowly and deliberately.
  - Never hurry or rush during winching.
  - Always pay attention to your surroundings.
  - You may need to change your winching strategy if it is not working.
  - Always remember that your winch is very powerful.
  - There are simply some situations that you and your winch will not be able to deal with. Do not be afraid to ask others to help when this happens.
1. Always inspect the vehicle, winch, winch cable and winch controls for any signs of damage or parts in need of repair or replacement before each use. *Pay particular attention to the first 3 feet (1 meter) of winch cable if the winch is being used (or has been used) for lifting an accessory plow assembly.* Promptly replace any worn or damaged cable.
  2. Never operate a winch or a vehicle in need of repair or service.
  3. Always apply your vehicle's park brake and/or park mechanism to hold the vehicle in place during winching. Use wheel chocks if needed.

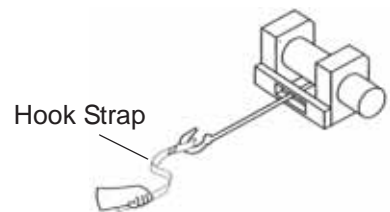

## Winch Operation

4. Always use the hook strap when handling the hook.

**WARNING!** Never put your fingers into the hook. This could lead to SEVERE INJURY.

- A. Attach the hook itself onto the load or use a tow strap or chain to secure the load to the winch cable.

**Tip:** A “tow strap” is NOT intended to stretch. A “recovery strap” is designed to stretch.

**WARNING!** Never use a recovery strap when winching due to the excessive energy that can be released if the winch cable breaks. This can result in SEVERE INJURY or DEATH. See the *Shock Loading* section on page 49.

- B. Never hook the winch cable back onto itself. This will damage the winch cable and may result in winch cable failure.

**WARNING!** Replace the winch cable at the first sign of damage to prevent SEVERE INJURY or DEATH in the event of failure. For your safety, always replace POLARIS winch parts (including the cable) with genuine POLARIS replacement parts available at your authorized POLARIS dealer.

- C. If possible, keep the winch cable aligned with the centerline of the winching vehicle. This will help the spooling of the winch cable and reduce the load on the fairlead.
- D. If freeing a stuck vehicle by attaching to a tree, use an item such as a tow strap to avoid damaging the tree during winch operation. Sharp cables and chains can damage and even kill trees. Please remember to TreadLightly® (treadlightly.org).
- E. Before operating the winch, be sure that the safety latch on the winch cable hook is fully seated when the load is attached.
- F. Never operate your winch with a damaged hook or latch. Always replace damaged parts before using the winch.

5. Never remove the hook strap from the hook.

6. Release the winch clutch and pull out the winch cable.

7. Pulling out as much cable as possible maximizes the winch’s pulling capacity. Always be sure that at least five (5) full turns of winch cable are wrapped around the winch drum at all times. The friction provided by this wrapped cable allows the drum to pull on the winch cable and move the load.



**NO**



**YES**

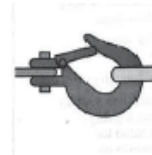

**YES**



**NO**

# WINCH GUIDE

## Winch Operation

8. Read and adhere to the following information for winch damping to ensure safe winch use.
  - A. In order to absorb energy that could be released by a winch cable failure, always place a “damper” on the winch cable. A damper can be a heavy jacket, tarp, or other soft, dense object. A damper can absorb much of the energy released if a winch cable breaks when winching. Even a tree limb can help as a damper if no other items are available to you.
  - B. Lay the damper on top of the mid-point of the winch cable length that is spooled out.
  - C. On a long pull, it may be necessary to stop winching so that the damper can be repositioned to the new mid-point of the winch cable. Always release the tension on the winch cable before repositioning the damper.
  - D. Avoid being directly in line with the winch cable whenever possible. Also, never permit others to stand near or in line with the winch cable during winch operation.
9. Never hook the winch cable back onto itself. This will damage the winch cable and may result in winch cable failure.
10. Never use straps, chains or other rigging items that are damaged or worn.
11. The **ONLY** time a winch-equipped vehicle should be moving when using the winch is when that vehicle itself is stuck. The winch-equipped vehicle should **NEVER** be in motion to “shock” load the winch cable in an attempt to move a second stuck vehicle. See the *Shock Loading* section on page 49. For your safety, always follow these guidelines when winching a vehicle free:
  - A. Release the winch clutch and spool out the necessary length of winch cable.
  - B. Align the winch cable as close as possible to the winching vehicle’s centerline.
  - C. Attach the winch cable hook to the anchor point or the stuck vehicle’s frame following instructions in this manual.
  - D. Re-engage the clutch on the winch.
  - E. Slowly winch in the slack in the winch cable.
  - F. Select the proper vehicle gear to propel the stuck vehicle in the direction of winching.
  - G. Shift to the lowest gear available on the stuck vehicle.
  - H. Slowly and carefully apply vehicle throttle and winch together to free the vehicle.
  - I. Stop winching as soon as the stuck vehicle is able to propel itself without the help of the winch.
  - J. Detach the winch cable hook.
  - K. Rewind the winch cable evenly back onto the winch drum following the instructions in this manual.
12. Never attempt to winch another stuck vehicle by attaching the winch cable to a suspension component, brush guard, bumper or cargo rack. Vehicle damage may result. Instead, attach the winch to a strong portion of the vehicle frame or hitch.



## Winch Operation

13. Extensive winching will run down the battery on the winching vehicle. Let the winching vehicle's engine run while operating the winch to prevent the battery from running low if winching for long periods.
14. The winch motor may become hot during winch use. If you winch for more than 45 seconds, or if the winch stalls during operation, stop winching and permit the winch to cool down for 10 minutes before using it again.
15. After winching is complete, especially if winching at an angle, it may be necessary to re-distribute the winch cable across the winch drum. You will need an assistant to perform this task.
  - A. Release the clutch on the winch.
  - B. Feed out the winch cable that is unevenly bunched up in one area.
  - C. Re-engage the winch clutch.
  - D. Have an assistant pull the winch cable tightly with about 100 lbs. (45 kg) of tension using the hook strap.
  - E. Slowly winch the cable in while your assistant moves the end of the winch cable back and forth horizontally to evenly distribute the winch cable on the drum.
  - F. Doing this reduces the chances of the winch cable "wedging" itself between lower layers of winch cable.

# WINCH GUIDE

## Winch Cable Care

For your safety, always replace POLARIS winch parts (including the cable) with genuine POLARIS replacement parts available at your authorized POLARIS dealer.

**WARNING!** Use of worn or damaged cable could lead to sudden failure and SEVERE INJURY.

1. Always inspect your winch before each use. Inspect for worn or loose parts including mounting hardware. Never use the winch if any part needs repair or replacement.
2. Always inspect your winch cable before each use. Inspect for worn or kinked winch cable.

A. A kinked winch cable made of wire rope is shown at right. Even after being "straightened out," this cable has already been permanently and severely damaged. Promptly discontinue use of a winch cable in this condition.



B. A kinked winch cable made of wire rope that has been "straightened out" is shown at right. Even though it may look usable, the cable has been permanently and severely damaged. It can no longer transmit the load that it could prior to kinking. Promptly discontinue use of a winch cable in this condition.



C. A winch cable made of synthetic rope should be inspected for signs of fraying. Replace the cable if fraying is observed (shown at right). Promptly discontinue use of a winch cable in this condition.



D. Also replace the winch cable if there are fused or melted fibers. Such an area of the synthetic rope will be stiff and appear smooth or glazed. Promptly discontinue use of a winch cable in this condition.

## Shock Loading

**WARNING!** Your winch cable is very strong but it is NOT designed for dynamic, or “shock” loading. Shock loading may tension a winch cable beyond its strength and cause the cable to break. The end of a broken winch cable under such high loading can cause SEVERE INJURY or DEATH to you and other bystanders.

*Winch cables are designed to NOT absorb energy. This is true of both wire-rope and synthetic-rope winch cables.*

1. Never attempt to “jerk” a load with the winch. For example, never take up slack in the winch cable by moving the winching vehicle in an attempt to move an object. This is a dangerous practice. It generates high winch cable loads that may exceed the strength of the cable. Even a slowly moving vehicle can create large shock loads in a winch cable.

**WARNING!** SEVERE INJURY or DEATH can result from a broken winch cable.

2. Never quickly turn the winch ON and OFF repeatedly (“jogging”). This puts extra load on the winch, winch cable, and generates excessive heat from the motor. This is a form of shock loading.
3. Never tow a vehicle or other object with your winch. Towing an object with a winch produces shock loading of the cable even when towing at slow speeds. Towing from a winch also positions the towing force high on the vehicle. This can cause instability of the vehicle and possibly lead to an accident.
4. Never use recovery straps with your winch. Recovery straps are designed to stretch and can store energy. This stored energy in the recovery strap is released if a winch cable fails making the event even more hazardous. Similarly, never use elastic “bungee” cords for winching.
5. Never use the winch to tie down a vehicle to a trailer or other transportation vehicle. This type of use also causes shock loading that can cause damage to the winch, winch cable, or vehicles used.

**Your winch cable is designed and tested to withstand the loads produced by the winch motor when operated from a stationary vehicle. Always remember that the winch and winch cable are NOT designed for shock loading.**

# WINCH GUIDE

## Winch Maintenance and Service Safety

**WARNING!** Improper or lack of winch maintenance and service could lead to SEVERE INJURY or DEATH. Always follow all winch instructions and warnings in this manual.

1. Always inspect your winch before each use. Inspect for worn or kinked winch cable. Also inspect for worn or loose parts including mounting hardware.
2. Permit your winch motor to cool down prior to servicing your winch.
3. Never work on your winch without first disconnecting the battery connections to prevent accidental activation of the winch
4. For your safety, always replace POLARIS winch parts (including the cable) with genuine POLARIS replacement parts available at your authorized POLARIS dealer.
5. Some winch models use wire rope as the winch cable. Other winches use a specially designed synthetic rope as the winch cable.
6. Never replace a synthetic-rope winch cable with a consumer-grade polymer rope such as can be purchased in a hardware store. Although they may look similar, they are NOT alike. A polymer rope not designed for winch use will stretch and store excessive energy when winching.

**WARNING!** Failure of a stretched rope under winching conditions will release all of the stored energy. This will increase the chances of SEVERE INJURY or DEATH.

**WARNING!**

# EMISSION CONTROL SYSTEMS

## Noise Emission Control System

Do not modify the engine, intake or exhaust components, as doing so may affect compliance with U.S.A. EPA noise control requirements (40 CFR 205) and local noise level requirements.

## Operation on Public Lands in the U.S.A.

Your POLARIS vehicle has a spark arrester that was tested and qualified to be in accordance with the USFS standard 5100-1c. Federal law requires that this spark arrester be installed and functional when the vehicle is operated on public lands.

Operation of off-road vehicles on public lands in the U.S.A. is regulated by 43 CFR 420. Violations are subject to monetary penalties. Federal regulations can be viewed online at [www.gpoaccess.gov/ecfr/](http://www.gpoaccess.gov/ecfr/).

## Crankcase Emission Control System

This engine is equipped with a closed crankcase system. Blow-by gases are forced back to the combustion chamber by the intake system. All exhaust gases exit through the exhaust system.

## Exhaust Emission Control System

The emissions from the exhaust of this vehicle are controlled by engine design, including factory-set fuel delivery and ignition. The engine and related components must be maintained at POLARIS specifications to achieve optimal performance.

Engine idle speed is the only adjustment POLARIS recommends that the operator perform. Any other adjustments should be performed by an authorized POLARIS dealer.

The emissions label is located on the frame under the seat.

## Electromagnetic Interference

This spark ignition system complies with Canadian ICES-002.

This vehicle complies with the EMC requirements of European directives 97/24/EC and 2004/108/EC.

**Non-ionizing Radiation:** This vehicle emits some electromagnetic energy. People with active or non-active implantable medical devices (such as heart monitoring or controlling devices) should review the limitations of their device and the applicable electromagnetic standards and directives that apply to this vehicle.

# MAINTENANCE

## Periodic Maintenance Chart

Careful periodic maintenance will help keep your vehicle in the safest, most reliable condition. Inspection, adjustment and lubrication of important components are explained in the periodic maintenance chart.

Inspect, clean, lubricate, adjust and replace parts as necessary. When inspection reveals the need for replacement parts, use genuine POLARIS parts available from your POLARIS dealer.

Record maintenance and service in the Maintenance Log beginning on page 98.

**Tip:** Service and adjustments are important for proper vehicle operation. If you're not familiar with safe service and adjustment procedures, have a qualified dealer perform these operations.

Maintenance intervals in the following chart are based upon average riding conditions and an average vehicle speed of approximately 10 MPH (16 km/h). Vehicles subjected to severe use must be inspected and serviced more frequently.

### Severe Use Definition

- Frequent immersion in mud, water or sand
- Frequent or prolonged operation in dusty environments
- Racing or race-style high RPM use
- Prolonged low speed, heavy load operation
- Extended idle
- Short trip cold weather operation

Pay special attention to the oil level. A rise in oil level during cold weather can indicate contaminants collecting in the oil sump or crankcase. Change oil immediately if the oil level begins to rise. Monitor the oil level, and if it continues to rise, discontinue use and determine the cause or see your dealer.

### Maintenance Chart Key

► Perform these operations more often for vehicles subjected to severe use.

**E** Emission-related service (Failure to conduct this maintenance will not void the emissions warranty but may affect emissions.)

**D** Have an authorized POLARIS dealer perform these services.

**WARNING!** Improperly performing the procedures marked with a “**D**” could result in component failure and lead to serious injury or death. Have an authorized POLARIS dealer perform these services.

## Periodic Maintenance Chart

Perform all services at whichever maintenance interval is reached first.

Item	Maintenance Interval (whichever comes first)			Remarks
	Hours	Calendar	Miles (Km)	
Steering	-	Pre-Ride	-	Make adjustments as need ed. See Pre-Ride Checklist on page 29.
Front suspension				
Rear suspension				
Tires				
Brake fluid level				
Brake pedal travel				
Brake system				
Wheels/fasteners				
Frame fasteners				
Engine oil level				
▶ E Air filter, pre-filter				
▶ E Air box sediment tube	-	Daily	-	Drain deposits when visible
Coolant (if applicable)	-	Daily	-	Check level daily, change coolant every 2 years
Headlamp/tail lamp	-	Daily	-	Check operation; apply dielectric grease if replacing
▶ E Air filter, main element	-	Weekly	-	Inspect; replace as needed
▶ D Brake pad wear	10 H	Monthly	-	Inspect periodically
Battery	20 H	Monthly	-	Check terminals; clean; test
▶ E Engine breather filter (if equipped)	25 H	Monthly	-	Inspect; replace if necessary
▶ Engine oil change (break-in)	25 H	1 M	-	Perform a break-in oil change at one month
▶ Front Gearcase Oil (if equipped)	25 H	1 M	-	Perform a break-in oil level check
▶ Middle Gearcase Oil (if equipped)	25 H	1 M	-	Perform a break-in oil level check
▶ Rear gearcase oil (if equipped)	25 H	1 M	-	Perform a break-in oil level check
▶ Transmission oil	25 H	1 M	-	Perform a break-in oil level check
▶ General lubrication	50 H	3 M	-	Lubricate all fittings, pivots, cables, etc.
Shift Linkage	50 H	6 M	-	Inspect, lubricate, adjust
D Steering	50 H	6 M	-	Lubricate
▶ Front Suspension	50 H	6 M	-	Lubricate
▶ Rear Suspension	50 H	6 M	-	Lubricate

▶ Perform these procedures more often for vehicles subjected to severe use.

E Emission-Related Service.

D Have an authorized POLARIS dealer perform these services.

# MAINTENANCE

## Periodic Maintenance Chart

Item		Maintenance Interval (whichever comes first)			Remarks
		Hours	Calendar	Miles (Km)	
	Carburetor float bowl	50 H	6 M	-	Drain bowl periodically and prior to storage
<b>D</b> <b>E</b>	Throttle cable	50 H	6 M	-	Inspect; adjust; lubricate; replace if necessary
<b>D</b> <b>E</b>	Choke cable	50 H	6 M	-	Inspect; adjust; lubricate; replace if necessary
<b>E</b>	Carburetor air intake ducts/flange	50 H	6 M	-	Inspect ducts for proper sealing/air leaks
	Drive belt	50 H	6 M	-	Inspect; adjust; replace as needed
	Cooling system (if applicable)	50 H	6 M	-	Inspect coolant strength seasonally; pressure test system yearly
▶	Oil lines, fasteners	50 H	6 M	-	Inspect for leaks and loose fittings
▶	Engine oil change	100 H	6 M	-	Perform a break-in oil change at one month
▶	Oil filter change	100 H	6 M	-	Replace with oil change
▶	Front Gearcase oil (if equipped)	100 H	6 M	-	Inspect level; change yearly
▶	Middle Gearcase oil (if equipped)	100 H	6 M	-	Inspect level; change yearly
▶	Rear gearcase oil (if equipped)	100 H	6 M	-	Inspect level; change yearly
▶	Transmission oil	100 H	6 M	-	Inspect level; change yearly
<b>D</b> <b>E</b>	Fuel system	100 H	12 M	-	Check for leaks at tank cap, lines, fuel valve, filter, pump, carburetor; replace lines every two years
<b>D</b>	Fuel filter	100 H	12 M	-	Replace yearly
▶	Radiator (in applicable)	100 H	12 M	-	Inspect; clean external surfaces
▶	Cooling Hoses	100 H	12 M	-	Inspect for leaks
▶	Engine mounts	100 H	12 M	-	Inspect
	Exhaust muffler/pipe	100 H	12 M	-	Inspect
▶ <b>E</b>	Spark plug	100 H	12 M	-	Inspect; replace as needed
<b>D</b> <b>E</b>	Ignition timing	100 H	12 M	-	Inspect
▶	Wiring	100 H	12 M	-	Inspect for wear, routing, security; apply dielectric grease to connectors subjected to water, mud, etc.
<b>D</b>	Clutches (drive and driven)	100 H	12 M	-	Inspect; clean; replace worn parts
<b>D</b>	Front wheel bearings	100 H	12 M	-	Inspect; replace as needed
<b>D</b>	Brake fluid	200 H	24 M	-	Change every two years
	Spark arrester	300 H	36 M	-	Clean out
	Idle speed	-			Adjust as needed
<b>D</b>	Toe adjustment	-			Inspect periodically; adjust when parts are replaced
<b>D</b> ▶	Auxiliary brake (if equipped)	-			Inspect daily; adjust as needed
	Headlight aim	-			Adjust as needed

▶ Perform these procedures more often for vehicles subjected to severe use.

**E** Emission-Related Service.

**D** Have an authorized POLARIS dealer perform these services.



## Lubrication Recommendations

Check and lubricate all components at the intervals outlined in the Periodic Maintenance Chart beginning on page 52, or more often under severe use, such as wet or dusty conditions. Items not listed in the chart should be lubricated at the general lubrication interval.

Item	Lube	Method
Engine Oil	PS-4 5W-50 4-Cycle Oil	See page 56.
Brake Fluid	DOT 4 Brake Fluid	See page 71.
Main Gearcase Oil (Transmission)	AGL Gearcase Lubricant & Transmission Fluid	See page 59.
Front Gearcase Oil	Demand Drive Fluid	See page 60.
Front Prop Shaft Yoke	U-Joint Grease	Locate fittings and grease (3 pumps maximum).

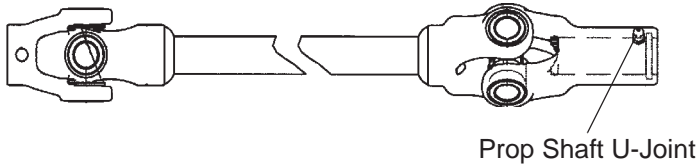

# MAINTENANCE

## Engine Oil

Always check and change the engine oil at the intervals outlined in the Periodic Maintenance Chart beginning on page 52. Always change the oil filter whenever changing oil.

**WARNING!** Vehicle operation with insufficient, deteriorated, or contaminated engine oil will cause accelerated wear and may result in engine seizure, accident, and injury. Always perform the maintenance procedures as outlined in the Periodic Maintenance Chart.

### Oil Recommendations

POLARIS recommends the use of POLARIS PS-4 5W-50 4-Cycle Oil. See page 85 for the part numbers of POLARIS products.

Oil may need to be changed more frequently if POLARIS oil is not used. Always use 5W-50 oil. Follow the manufacturer's recommendations for ambient temperature operation.

**NOTICE:** Mixing brands or using a non-recommended oil may cause serious engine damage. Always use the recommended oil. Never substitute or mix oil brands.

### Oil Check

The oil tank is located under the seat.

1. Position the vehicle on a level surface. Place the transmission in **PARK**.
2. Start the engine and allow it to idle for 20-30 seconds. Stop the engine.
3. Remove the seat. See page 27.
4. Remove the dipstick. Wipe it dry with a clean cloth.
5. Reinstall the dipstick. Screw it in completely.
6. Remove the dipstick. Make sure that the oil level is in the safe range. Add oil if necessary. Do not overfill.
7. Reinstall the dipstick.

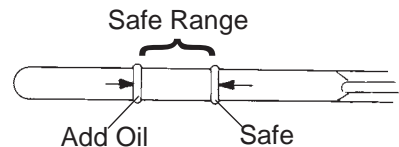
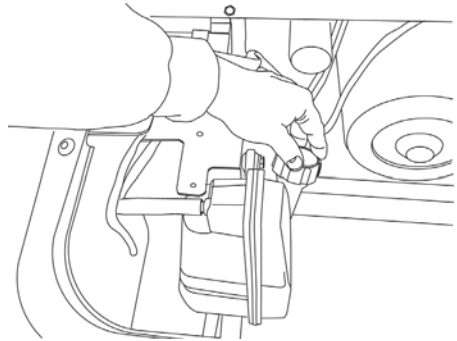

## Engine Oil Oil and Filter Change

Always change the oil and filter at the intervals outlined in the Periodic Maintenance Chart beginning on page 52. Always change the oil filter whenever changing oil.

1. Position the vehicle on a level surface.
2. Place the transmission in PARK.
3. Start the engine. Allow it to idle for two to three minutes. Stop the engine.
4. Clean the area around the oil tank drain plug.
5. Place a drain pan under the oil tank.

**CAUTION!** Hot oil can cause burns to skin. Do not allow hot oil to contact skin.

6. Remove the drain plug. Allow the oil to drain completely.
7. Install a new sealing washer on the drain plug. The sealing surfaces on drain plug and oil tank should be clean and free of burrs, nicks or scratches.
8. Reinstall the drain plug. Torque to 14 ft. lbs. (19 Nm).
9. Disconnect the lower oil delivery hose and remove the screen fitting from the oil tank. Clean the fitting.

**Tip:** The fitting threads must be sealed with LOCTITE PST 505 or PTFE seal tape.

10. Reinstall the screen fitting and rotate the fitting clockwise a minimum of 2 1/2 turns into the tank threads. Continue to rotate the fitting until the nipple of the fitting aligns with the mark on the tank.

**Tip:** Do not over-tighten. Maximum torque for the screen fitting is 25 ft. lbs. (34 Nm).

11. Reattach the oil line.
12. Place shop towels under the oil filter. Using an oil filter wrench, turn the filter counter-clockwise to remove it.
13. Using a clean dry cloth, clean the filter sealing surface on the engine.

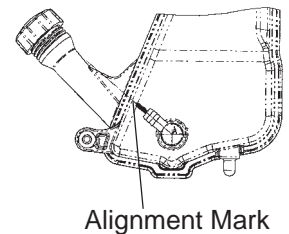
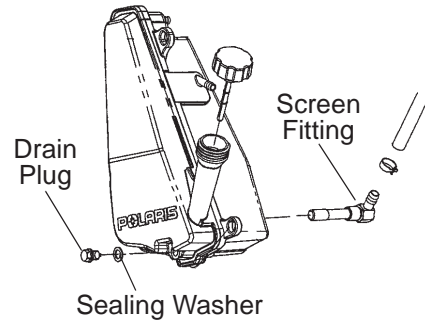

# MAINTENANCE

## Engine Oil

### Oil and Filter Change

14. Lubricate the gasket on the new filter with a film of new engine oil. Make sure the gasket is in good condition. Make sure the gasket from the old filter is not still on the engine.
15. Install the new filter and turn by hand until the filter gasket contacts the sealing surface, then turn and additional 1/2 turn.
16. Approximately one cup of engine oil will remain in the crankcase. To drain, remove the drain plug on the lower right side of the crankcase.

**Tip:** The sealing surfaces on the drain plug and crankcase should be clean and free of burrs, nicks or scratches.

17. Reinstall the drain plug. Torque to 14 ft. lbs. (19 Nm).
18. Remove the dipstick. Add two quarts (1.9 l) of recommended oil. If the sump is not drained, add about 1 3/4 quarts (1.6 l) initially.
19. Reinstall the dipstick.
20. **Prime the oil pump using the procedure below.** Then stop the engine and inspect for leaks.
21. Check the oil level on the dipstick. Add oil as necessary to bring the level to the upper mark on the dipstick.
22. Dispose of used filter and oil properly.

### Oil Pump Priming

This priming procedure must be performed whenever the oil hose connection between the oil tank and pump inlet has been disconnected.

1. Clamp or pinch off the vent line approximately 2" (5 cm) from the oil tank, between the end of the oil tank vent fitting and the vent line's pressure relief slit.
2. Start the engine. Allow it to idle for 10-20 seconds.
3. Remove the vent line clamp. If the line is bled properly, you should hear a rush of air, indicating that the line is properly primed and ready for operation.

**Tip:** If you do not hear air, the line has not bled. Repeat the priming procedure.

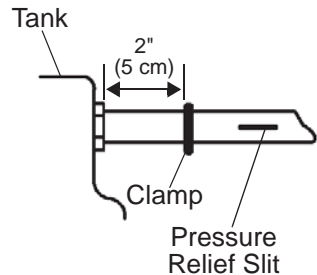

## Gearcases

### Gearcase Specification Chart

Gearcase	Lubricant	Capacity	Fill Plug(s) Torque	Drain Plug Torque
Main Gearcase (Transmission)	AGL Gearcase Lubricant & Transmission Fluid	34 oz. (1000 ml)	12 ft. lbs. (16.3 Nm)	12 ft. lbs. (16.3 Nm)
Front Gearcase	Demand Drive Fluid	9.3 oz. (275 ml)	8-10 ft. lbs. (11-13.6 Nm)	11 ft. lbs. (15 Nm)

### Transmission (Main Gearcase)

Always check and change the transmission oil at the intervals outlined in the Periodic Maintenance Chart beginning on page 52. Maintain the oil level even with the bottom of the fill plug hole threads.

Refer to the Gearcase Specifications Chart for recommended lubricants, capacities and torque specifications. See page 85 for the part numbers of POLARIS products.

#### Oil Check

The fill plug is located on the rear of the gearcase. A level check/alternate fill plug is located on the side of the gearcase. Maintain the oil level even with the bottom of the level check/fill plug hole threads.

1. Position the vehicle on a level surface.
2. Remove the level check/fill plug. Check the oil level.
3. Remove the rear fill plug and add the recommended oil as needed.
4. Reinstall both fill plugs. Torque to specification.

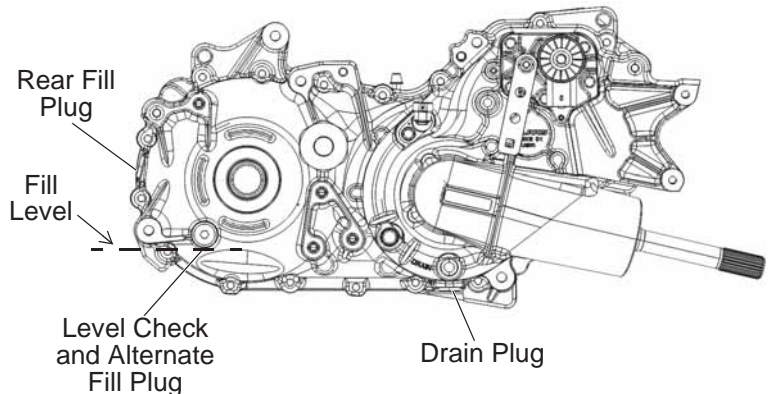

#### Oil Change

The drain plug is located near the bottom of the gearcase.

1. Remove the rear fill plug and the level check/fill plug.
2. Place a drain pan under the gearcase.
3. Remove the drain plug. Allow the oil to drain completely.
4. Clean and reinstall the drain plug. Torque to specification.
5. Add the recommended oil.
6. Reinstall both fill plugs. Torque to specification.
7. Check for leaks. Dispose of used oil properly.

# MAINTENANCE

## Gearcases

### Front Gearcase

Always check and change the front gearcase oil at the intervals outlined in the Periodic Maintenance Chart beginning on page 52. Maintain the oil level even with the bottom thread of the fill plug hole.

Refer to the Gearcase Specifications Chart on page 59 for recommended lubricants, capacities and torque specifications. See page 85 for the part numbers of POLARIS products.

### Oil Check

The front gearcase fill plug is located on the right side of the front gearcase.

1. Position the vehicle on a level surface.
2. Remove the fill plug. Check the oil level.
3. Add the recommended oil as needed.
4. Reinstall the fill plug. Torque to specification.

### Oil Change

1. Support the vehicle securely with a jackstand.
2. Remove the front tire on the driver's side.
3. Remove the fill plug.
4. Place a drain pan under the drain plug on the bottom right-hand side.
5. Remove the drain plug. Drain the oil.
6. Clean the drain plug. Reinstall the drain plug. Torque to specification.
7. Add the recommended oil.
8. Reinstall the fill plug. Torque to specification.
9. Check for leaks.
10. Discard used oil properly.

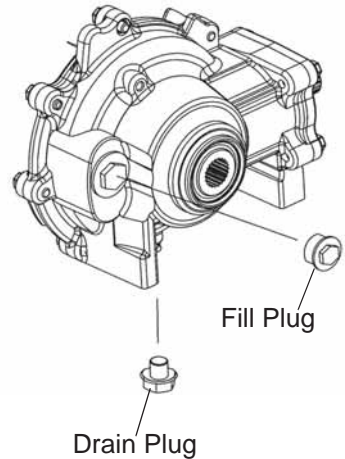

## Spark Plugs

### Spark Plug Recommendations

Refer to the specifications section beginning on page 86 for the recommended spark plug type for your vehicle. Always torque spark plugs to specification.

**NOTICE:** Using non-recommended spark plugs can result in serious engine damage. Always use POLARIS-recommended spark plugs.

### Spark Plug Gap/Torque

Model	Electrode Gap	New Plug Torque	Used Plug Torque
RANGER 400	.036" (.9 mm)	9-11 ft. lbs. (12-15 Nm)	9-11 ft. lbs. (12-15 Nm)

### Spark Plug Inspection

Spark plug condition is indicative of engine operation. The spark plug firing end condition should be read after the engine is warmed up and the vehicle is driven at higher speeds. Immediately check the spark plug for correct color.

**CAUTION!** A hot exhaust system and engine can cause burns. Wear protective gloves when removing a spark plug for inspection.

1. Remove the seat to access the engine compartment.
2. Remove the spark plug cap. Using the spark plug wrench provided in the tool kit, remove the plug by rotating it counter-clockwise.
3. Reverse the procedure for spark plug installation. Torque to specification.

### Normal Plug

The normal insulator tip is gray, tan or light brown. There will be few combustion deposits. The electrodes are not burned or eroded. This indicates the proper type and heat range for the engine and the service.

The tip should not be white. A white insulator tip indicates overheating, caused by use of an improper spark plug or incorrect carburetion adjustments.

### Wet Fouled Plug

The wet fouled insulator tip is black. A damp oil film covers the firing end. There may be a carbon layer over the entire nose. Generally, the electrodes are not worn. General causes of fouling are excessive oil, use of non-recommended oil, improper use of the choke, or incorrect throttle body/carburetor adjustments.

# MAINTENANCE

## Cooling System

The engine coolant level is controlled or maintained by the recovery system. The recovery system components are the overflow bottle, radiator filler neck, radiator pressure cap and connecting hose.

As coolant operating temperature increases, the expanding (heated) excess coolant is forced out of the radiator, past the pressure cap, and into the overflow bottle. As engine coolant temperature decreases, the contracting (cooled) coolant is drawn back up from the tank, past the pressure cap, and into the radiator.

Some coolant level drop on new vehicles is normal as the system is purging itself of trapped air. Observe coolant levels and maintain as recommended by adding coolant to the overflow bottle.

### Adding or Changing Coolant

To ensure that the coolant maintains its ability to protect the engine, we recommend that the system be completely drained every two years and a fresh mixture of antifreeze and water added. POLARIS recommends the use of POLARIS Antifreeze 60/40 premix or a 50/50 mixture of high quality aluminum compatible anti-freeze/coolant and distilled water. POLARIS Antifreeze is already premixed and ready to use. Do not dilute with water. See page 85 for the part numbers of POLARIS products.

Always follow the manufacturer's mixing recommendations for the freeze protection required in your area.

Any time the cooling system has been drained for maintenance or repair, replace the coolant. If the recovery bottle has run dry, the level in the radiator should be inspected. Add coolant as needed.

### Radiator and Cooling Fan

Always check and clean the screen and radiator fins at the intervals outlined in the Periodic Maintenance Chart beginning on page 52. Do not obstruct or deflect air flow through the radiator by installing unauthorized accessories in front of the radiator or behind the cooling fan. Interference with the radiator air flow can lead to overheating and consequent engine damage.

**NOTICE:** Washing the vehicle with a high-pressure hose could damage the radiator fins and impair the radiator's effectiveness. Using a high-pressure system is not recommended.



## Cooling System

### Overflow Bottle Coolant Level

Always check and change the coolant at the intervals outlined in the Periodic Maintenance Chart beginning on page 52. Maintain the coolant level between the minimum and maximum marks on the bottle (when the fluid is cool).

The overflow bottle is located in front of the right front wheel.

1. Position the vehicle on a level surface.
2. View the coolant level in the overflow bottle.
3. If the coolant level is below the safe operating range, lift the hood and locate the overflow bottle lid. Remove the cap and use a funnel to add coolant through the filler opening. Reinstall the cap.

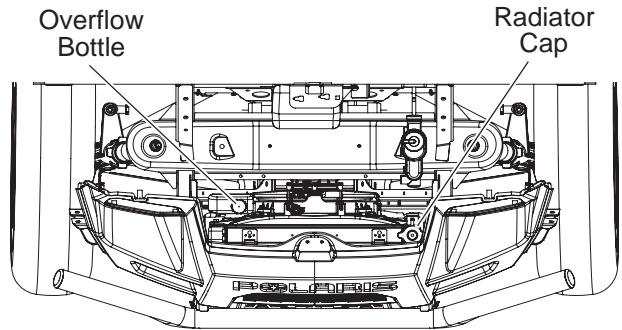

**Tip:** If coolant must be added often, or if the overflow bottle runs completely dry, there may be a leak in the system. Have the cooling system inspected by your POLARIS dealer.

### Radiator Coolant Level

Always check and clean the screen and radiator fins at the intervals outlined in the Periodic Maintenance Chart beginning on page 52. Do not obstruct or deflect air flow through the radiator by installing unauthorized accessories in front of the radiator or behind the cooling fan. Interference with the radiator air flow can lead to overheating and consequentially, engine damage.

1. Lift the hood.

**CAUTION!** Escaping steam can cause burns. Never remove the pressure cap while the engine is warm or hot. Always allow the engine to cool before removing the pressure cap.

2. Slowly remove the radiator cap.
3. View the coolant level through the opening.
4. Use a funnel and slowly add coolant as needed.

**Tip:** This procedure is required only if the cooling system has been drained for maintenance and/or repair. But if the overflow bottle has run dry, the level in the radiator should also be inspected.

5. Reinstall the pressure cap. Use of a non-standard pressure cap will not allow the recovery system to function properly. See your dealer for the correct replacement part.

# MAINTENANCE

## POLARIS Variable Transmission (PVT) System

### **⚠ WARNING**

Failure to comply with the instructions in this warning can result in severe injury or death.

Do not modify any component of the PVT system. Doing so may reduce its strength so that a failure may occur at a high speed. The PVT system has been precision balanced. Any modification will cause the system to be out of balance, creating vibration and additional loads on components.

The PVT system rotates at high speeds, creating large amounts of force on clutch components. As the owner, you have the following responsibilities for your own safety and the safety of others:

- Always follow all recommended maintenance procedures. Always look for and remove debris inside and around the clutch and vent system when replacing the belt.
- See your dealer as outlined in the owner's manual.
- This PVT system is intended for use on POLARIS products only. Do not install it in any other product.
- Always make sure the PVT housing is securely in place during operation.

### **Belt Replacement/Debris Removal**

If a belt fails, always clean any debris from the duct and from the clutch and engine compartments when replacing the belt.

**WARNING!** Failure to remove ALL debris when replacing the belt could result in vehicle damage, loss of control and severe injury or death.

1. Remove the seat and the underseat storage box.
2. Remove the clutch cover screws and open the clutch cover. Remove all debris wrapped in and around the PVT system.
3. Remove all debris from the entire clutch air duct passage.
4. Check for signs of damage to seals on the transmission and engine. See your dealer promptly for service if any seals appear to be damaged.

**Tip:** Belt slip is responsible for creating excessive heat that destroys belts, wears clutch components and causes outer clutch covers to fail. Switch to low range while operating at slower speeds to extend the life of the PVT components (belt, cover, etc.).

## **POLARIS Variable Transmission (PVT) System**

### **PVT Drying**

There may be some instances when water is ingested into the PVT system. Use the following instructions to dry it out before operating.

1. Position the vehicle on a level surface.
2. Remove the drain plug. Allow the water to drain completely. Reinstall the drain plug.
3. Place the transmission in PARK.
4. Start the engine.
5. Apply varying throttle for 10-15 seconds to expel the moisture and air-dry the belt and clutches. Do not hold the throttle wide open for more than 10 seconds.
6. Allow the engine RPM to settle to idle speed. Apply the brakes. Shift the transmission to the lowest available range.
7. Test for belt slippage. If the belt slips, repeat the process.
8. Take the vehicle to your dealer for service as soon as possible.

# MAINTENANCE

## Vehicle Immersion

**NOTICE:** If your vehicle becomes immersed, major engine damage can result if the machine is not thoroughly inspected. Take the vehicle to your dealer before starting the engine.

If it's impossible to take your *RANGER* to a dealer before starting it, follow the steps outlined below.

1. Move the vehicle to dry land or at the very least, to water below the footrests.
2. Disconnect the fuel pump wires.
3. Remove the spark plug.
4. Place a clean container under the engine and loosen the carburetor drain screw two turns.
5. Dry any water present in the air box. Filter replacement is required if water is present.
6. Thoroughly dry the air pre-cleaner located under the hood.
7. Turn the engine over several times using the electric start.
8. Inspect the drained fuel for water or sediment.
9. Dry the spark plug and reinstall it, or install a new plug.
10. Tighten the carburetor drain screw.
11. Reconnect the fuel pump wires.
12. Attempt to start the engine. If necessary, repeat the drying procedure.
13. Take the vehicle to your dealer for service as soon as possible, whether you succeed in starting it or not.
14. If water has been ingested into the PVT follow the procedure on page 65 for drying.

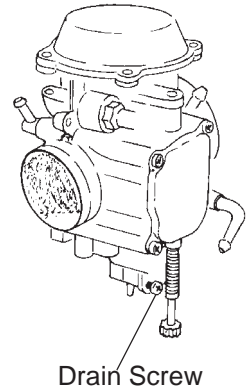

## Cylinder Head/Cylinder Base Fastener Torque

Have your dealer check the cylinder head and cylinder base fasteners for proper torque at the first service or after 25 hours.

## Filter Systems

### Air Filter

Always change the air filter at the intervals outlined in the Periodic Maintenance Chart beginning on page 52. Service the air filter more frequently if the vehicle is operated in wet conditions or at high throttle openings for extended periods.

1. Lift the cargo box to access the air box.
2. Remove the air box cover and inspect the gasket. It should adhere tightly to the cover and seal all the way around.
3. Remove the air filter.
4. Do not attempt to clean the main element. Install a new air filter.

**Tip:** Apply a small amount of general purpose grease to the sealing edges of the filter before installing.

5. Inspect the air box for oil or water deposits. If present, drain them into a suitable container.

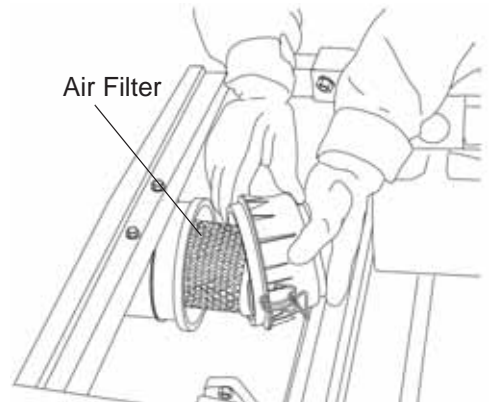

### Fuel Filter

Your POLARIS vehicle is equipped with an in-line fuel filter. Have your dealer replace it after every 100 hours of operation. Do not attempt to clean the fuel filter.

### Breather Filter and Hoses

1. Lift the cargo box and locate the air box.
2. Follow the right-hand breather line out the side of the air box and locate the filter.
3. Remove and inspect the filter for debris. Blow gently through the filter in the direction of the arrow to check for clogging. Replace as needed.
4. Check hoses for cracks, deterioration, abrasion, or leaks. Replace as needed.
5. Reinstall the filter with the arrow pointing toward the engine. Secure the clamps.



**NOTICE:** Operation of the vehicle without a breather filter can cause engine damage. Always reinstall the breather filter after removing it for service.

# MAINTENANCE

## Carburetor

The idle speed adjustment should be performed as outlined in the Periodic Maintenance Chart, or whenever the idle speed is changed. Recommended engine idle RPM is 1200 +/- 200.

### Carburetor/Engine Idle RPM Adjustment

If the engine idle speed is unsatisfactory and all other conditions are favorable, the carburetor can be adjusted.

1. Apply the brakes.
2. Place the transmission in PARK.
3. Start the engine and allow it to warm up for approximately five minutes.
4. Remove the seat. Locate the idle adjust screw.
5. Place the transmission in gear.
6. Turn the screw in (clockwise) to raise RPM. Turn the screw out (counter-clockwise) to lower RPM.

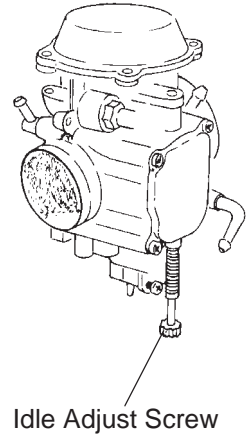

## Spark Arrester

### **⚠ WARNING**

Failure to heed the following warnings while servicing the spark arrester could result in serious injury or death.

- Do not perform service on the spark arrester while the system is hot. Exhaust system temperatures can reach 1000° F. Allow components to cool sufficiently before proceeding.
- Remove any combustible materials from the area.
- Wear eye protection and gloves.
- Do not stand behind or in front of the vehicle while purging.
- Never run the engine in an enclosed area. Exhaust contains poisonous carbon monoxide gas that can cause loss of consciousness or death in a very short time.
- Never operate without the spark arrester.
- Never go under the vehicle while it's inclined.

Use the following procedure to periodically purge accumulated carbon from the exhaust pipe.

1. Remove the arrester clean-out plug located on the bottom of the muffler.
2. Place the transmission in PARK.
3. Start the engine.
4. Purge accumulated carbon from the system by momentarily revving the engine several times.
5. If carbon is expelled, cover or plug the exhaust outlet and rap on the pipe around the clean-out plug while revving the engine several more times.
6. If particles are still suspected to be in the muffler, elevate the rear of the vehicle one foot higher than the front. Block the wheels.
7. Repeat steps 4 and 5 until no more particles are expelled when the engine is revved.
8. Stop the engine. Allow the arrester to cool.
9. Reinstall the arrester plug and remove the outlet cover or plug.

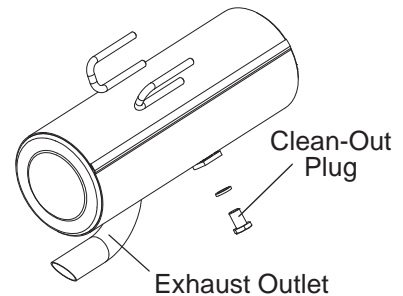

# MAINTENANCE

## Throttle System

### **⚠ WARNING**

Failure to check or maintain proper operation of the throttle system can result in an accident and lead to serious injury or death if the throttle pedal sticks during operation.

Always check the pedal for free movement and return before starting the engine and occasionally during operation. Never start or operate this vehicle if it has a sticking or improperly operating throttle pedal. Immediately contact your dealer for service if throttle problems arise.

### Throttle Freeplay

If the throttle pedal has excessive play due to cable stretch or misadjustment, it will cause a delay in throttle response, especially at low engine speed. The throttle may also not open fully. If the throttle pedal has no freeplay, the throttle may be hard to control, and the idle speed may be erratic.

Check the throttle pedal freeplay at the intervals outlined in the Periodic Maintenance Chart beginning on page 52. Adjust the freeplay if necessary.

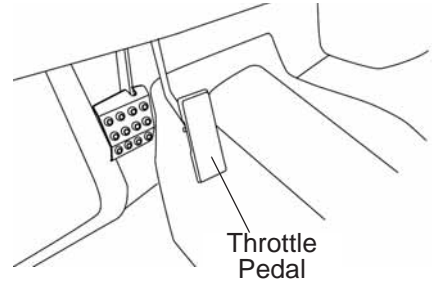

### Throttle Freeplay Inspection

1. Place the transmission in PARK.
2. Start the engine. Allow it to warm up thoroughly.
3. Measure the distance the throttle pedal moves before the engine begins to pick up speed. Freeplay should be 1/16 to 1/8 inches (1.6-3.2 mm).

### Throttle Freeplay Adjustment

1. Remove the lower seat base.
2. Locate the throttle cable adjuster at the throttle body.
3. Slide the cable adjuster boot away from the adjuster.
4. Using a 10mm open-end wrench, loosen the adjustment jam nut.
5. Using an 8mm open-end wrench, move the cable adjuster until 1/16 to 1/8 inches (1.6-3.2 mm) of freeplay is achieved at the throttle pedal.

**Tip:** While adjusting, lightly move the throttle pedal up and down.

6. Tighten the jam nut.
7. Apply a small amount of all-purpose grease to the inside of the boot and slide it over the cable adjuster to its original position.
8. Reinstall the lower seat base.
9. Perform a test drive to ensure proper throttle operation.



## Brakes

The front and rear brakes are hydraulic disc type brakes. Press down on the brake pedal to engage the brakes. See page 23.

### Brake Fluid

Inspect the brake system routinely. Inspect the level of the brake fluid before each operation.

**WARNING!** After opening a bottle of brake fluid, always discard any unused portion. Never store or use a partial bottle. Brake fluid is hygroscopic, meaning it rapidly absorbs moisture from the air. The moisture causes the boiling temperature of the brake fluid to drop, which can lead to early brake fade and the possibility of accident or severe injury.

Change the brake fluid every two years and any time the fluid becomes contaminated, the fluid level is below the minimum, or if the type and brand of the fluid in the reservoir are unknown. See page 55 for fluid recommendations.

1. Position the vehicle on a level surface.
2. View the brake fluid level at the reservoir in the driver's side wheel well. The level should be between the upper (MAX) and lower (MIN) level lines.
3. If the fluid level is lower than the upper level line, add brake fluid to the upper (MAX) line.
4. Apply the brake forcefully for a few seconds and check for fluid leakage around the fittings.

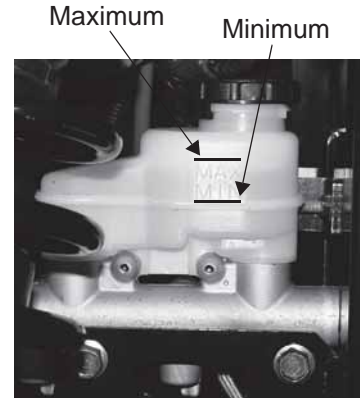

### Brake Inspection

1. Check the brake system for fluid leaks.
2. Check the brake pedal for excessive travel or a spongy feel.
3. Check the friction pads for wear, damage and looseness.
4. Check brake discs for signs of cracks, excessive corrosion, warping or other damage. Clean any grease using an approved brake cleaner or alcohol.

**WARNING!** Do not apply WD-40 or any petroleum product to brake discs. These types of products are flammable and may also reduce the friction between the brake pad and caliper.

5. Inspect the brake disc spline and pad wear surface for excessive wear. Change pads when worn to 3/64" (1 mm).

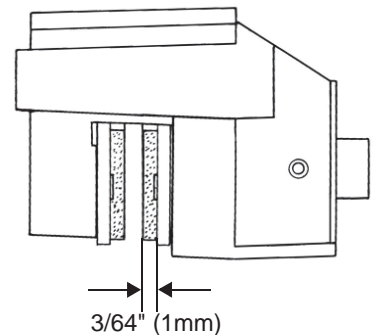

# MAINTENANCE

## Steering Wheel Inspection

Check the steering wheel for specified freeplay and smooth operation at the intervals outlined in the Periodic Maintenance Chart beginning on page 52.

1. Position the vehicle on a level surface.
2. Lightly turn the steering wheel left and right.
3. There should be 0.8"-1.0" (20-25 mm) of freeplay.
4. If there is excessive freeplay or strange noises, or the steering feels rough or "catchy," have the steering system inspected by an authorized POLARIS dealer.

## Spring Adjustment

Adjust the front and rear shock absorber springs by rotating the adjustment cam either clockwise or counter-clockwise to increase or decrease spring tension.

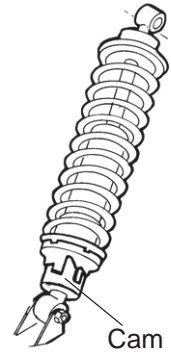

## Tires

### ⚠ WARNING

Operating your vehicle with worn tires, improperly inflated tires, non-standard tires or improperly installed tires will affect vehicle handling and could cause an accident resulting in serious injury or death. Always follow all tire maintenance procedures as outlined in this manual and on the labels on the vehicle. Always use POLARIS-approved size and type of tires for this vehicle when replacing tires.

### Tire Tread Depth

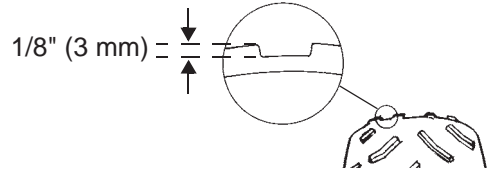

Always replace tires when tread depth is worn to 1/8" (3 mm) or less.



### Axle and Wheel Nut Torque Specifications

Inspect the following items occasionally for tightness, and if they've been loosened for maintenance service.

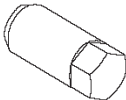
Do not lubricate the stud or the lug nut.

Nut Type	Location	Nut Torque
Lug Nut (Aluminum Wheels) 	Front and Rear	30 ft. lbs. (41 Nm) PLUS 1/4 TURN
Nut and Washer (Steel Wheels) 	Front and Rear	35 ft. lbs. (47 Nm)
Spindle Nut	Front	70 ft. lbs. (95 Nm)
Hub Retaining Nuts	Center and Rear	110 ft. lbs. (150 Nm)

# MAINTENANCE

## Tires

### Wheel Removal

1. Apply the brakes.
2. Place the transmission in PARK.
3. Stop the engine.
4. Loosen the wheel nuts slightly.
5. Elevate the side of the vehicle by placing a suitable stand under the frame.
6. Remove the wheel nuts and washers. Remove the wheel.

### Wheel Installation

1. Place the transmission in PARK.
2. Place the wheel in the correct position on the wheel hub. Be sure the valve stem is toward the outside and rotation arrows on the tire point toward forward rotation.

**WARNING!** Improperly installed wheels can adversely affect tire wear and vehicle handling, which can result in serious injury or death. Always ensure that all nuts are torqued to specification. Do not service axle nuts that have a cotter pin installed. See your POLARIS dealer.

3. Attach the wheel nuts and washers and finger tighten.
4. Carefully lower the vehicle to the ground.
5. Torque the wheel nuts to specification. See page 73.

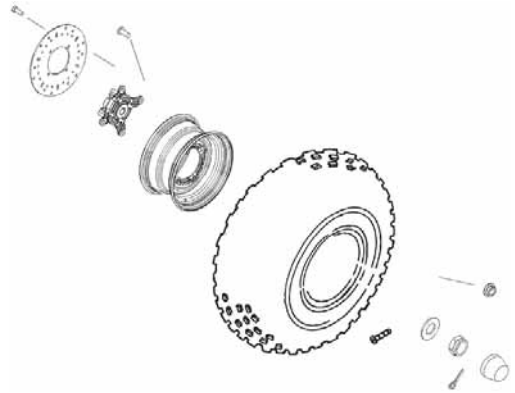

## Lights

Poor lighting can result in reduced visibility when driving. Headlight and taillight lenses become dirty during normal operation. Clean lights frequently and replace burned out lamps promptly. Do not operate this vehicle at night or in low light conditions until the headlight is replaced. Always make sure lights are adjusted properly for best visibility.

When servicing a halogen lamp, don't touch the lamp with bare fingers. Oil from your skin leaves a residue, causing a hot spot that will shorten the life of the lamp.

## Headlight Beam Adjustment

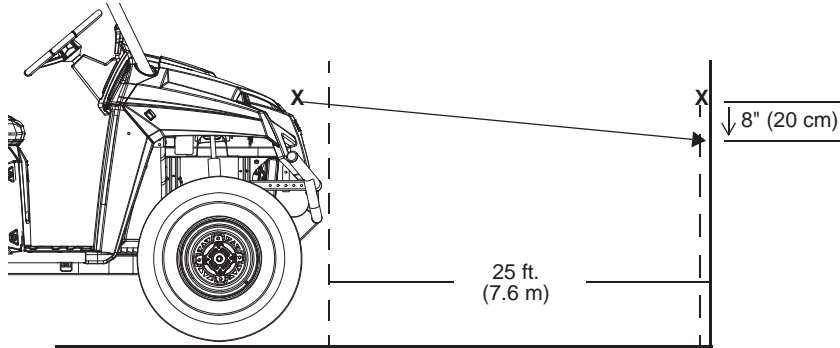

1. Place the vehicle on a level surface with the headlight approximately 25 ft. (7.6 m) from a wall.
2. Measure the distance from the floor to the center of the headlight and make a mark on the wall at the same height.
3. Apply the brakes. Start the engine. Turn on the headlights.
4. Observe the headlight aim. The most intense part of the headlight beam should be aimed 8" (20 cm) below the mark placed on the wall. Include the weight of a rider on the seat while performing this step.
5. If a headlight needs adjustment, access the adjustment screw under the hood or through the wheel well.
6. Loosen the screw, adjust the headlight, and tighten the screw.
7. Repeat steps 4-6 until the lamp is properly adjusted.

# MAINTENANCE

## Lights

### Headlight Lamp Replacement

1. Open the hood.

**CAUTION!** Hot components can cause burns to skin. Allow lamps to cool before servicing.

2. Unplug the headlamp from the wiring harness. Be sure to pull on the connector, not on the wiring.
3. Turn the lamp counter-clockwise to remove it.
4. Install the new lamp.

**Tip:** Make sure the tab on the lamp locates properly in the housing.

5. Reinstall the harness assembly into the headlight assembly.



### Brake Lights

When the brake pedal is depressed, the brake light comes on. Check the brake light before each ride.

1. Turn the ignition switch to the ON position.
2. Depress the brake pedal. The brake light should come on after about 10mm (0.4 in.) of pedal travel. If the light doesn't come on, check the bulb.

### Indicator Lamp Replacement

1. Lift the hood.
2. Reach in behind the console panel and lift the release to unplug the light from the harness.
3. Using a flathead screwdriver, press on the tab on the top of the light to remove the indicator light assembly from the console panel.
4. Locate the expired lamp. Using a screwdriver, rotate the lamp 1/4 turn counter-clockwise.
5. Grip the lamp with a needle-nose pliers and remove it from the assembly.
6. Install the new lamp. Using a screwdriver, rotate the lamp 1/4 turn clockwise to seat it.
7. Snap the assembly back into the console panel. Reconnect the harness.
8. Close the hood.

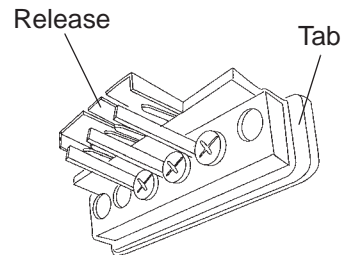

## Battery

### **⚠ WARNING**

Battery electrolyte is poisonous. It contains sulfuric acid. Serious burns can result from contact with skin, eyes or clothing.

Antidote:

**External:** Flush with water.

**Internal:** Drink large quantities of water or milk. Follow with milk of magnesia, beaten egg, or vegetable oil. Call physician immediately.

**Eyes:** Flush with water for 15 minutes and get prompt medical attention.

Batteries produce explosive gases. Keep sparks, flame, cigarettes, etc. away. Ventilate when charging or using in an enclosed space. Always shield eyes when working near batteries. **KEEP OUT OF REACH OF CHILDREN.**

Your vehicle may have either a sealed battery, which requires little maintenance, or a conventional battery. A sealed battery can be identified by its flat covers on the top of the battery. A conventional battery has six filler caps on the top of the battery.

Always keep battery terminals and connections free of corrosion. If cleaning is necessary, remove the corrosion with a stiff wire brush. Wash with a solution of one tablespoon baking soda and one cup water. Rinse well with tap water and dry off with clean shop towels. Coat the terminals with dielectric grease or petroleum jelly. Be careful not to allow cleaning solution or tap water into the battery.

**Tip:** If accessories are using power constantly while the vehicle is operated in colder temperatures (below 30° F./-1° C.), a 30 amp/hour battery will provide the best performance, including improved starting performance.

# MAINTENANCE

## Battery

### Battery Removal

#### **⚠ WARNING**

Improperly connecting or disconnecting battery cables can result in an explosion and cause serious injury or death. When removing the battery, always disconnect the negative (black) cable first. When reinstalling the battery, always connect the negative (black) cable last.

1. Remove the seat.
2. On conventional batteries, remove the battery vent tube.
3. Disconnect the black (-) battery cable first.
4. Disconnect the red (+) battery cable last.
5. Lift the battery out of the vehicle. Be careful not to tip a conventional battery sideways, which could spill electrolyte.

**NOTICE:** If electrolyte spills, immediately wash it off with a solution of one tablespoon baking soda and one cup water to prevent damage to the vehicle.

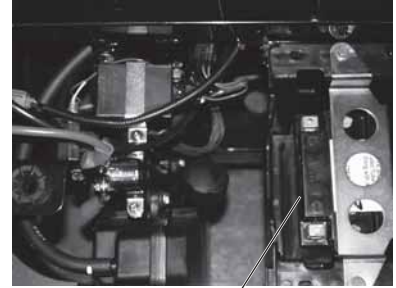

Battery

### Battery Installation

Using a new battery that has not been fully charged can damage the battery and result in a shorter life. It can also hinder vehicle performance. Always install a fully charged battery.

1. Ensure that the battery is fully charged.
2. Place the battery in the battery holder.
3. With conventional batteries, install the battery vent tube (sealed batteries do not have a vent tube). The vent tube must be free of obstructions and securely installed. Route the tube away from the frame and vehicle body to prevent contact with electrolyte.

**WARNING!** Battery gases could accumulate in an improperly installed vent tube and cause an explosion, resulting in serious injury or death. Always ensure that the vent tube is free of obstructions and is securely installed as recommended.

4. Coat the terminals with dielectric grease or petroleum jelly.
5. Connect and tighten the red positive (+) cable first.
6. Connect and tighten the black negative (-) cable last.
7. Verify that cables are properly routed. Cables should be safely tucked away at the front and rear of the battery.
8. Install the battery hold-down strap.



## Battery

### Battery Storage

Whenever the vehicle is not used for a period of three months or more, remove the battery from the vehicle, ensure that it's fully charged, and store it out of the sun in a cool, dry place. Check battery voltage each month during storage and recharge as needed to maintain a full charge. See page 80.

POLARIS recommends maintaining battery charge by using a POLARIS Battery Tender charger or by charging about once a month to make up for normal self-discharge. Battery Tender can be left connected during the storage period, and will automatically charge the battery if the voltage drops below a pre-determined point. See page 85 for the part numbers of POLARIS products.

### Battery Fluid (Conventional Battery)

A poorly maintained battery will deteriorate rapidly. Check the battery fluid level often. Maintain the fluid level between the upper and lower level marks.

Add only distilled water. Tap water contains minerals that are harmful to a battery.

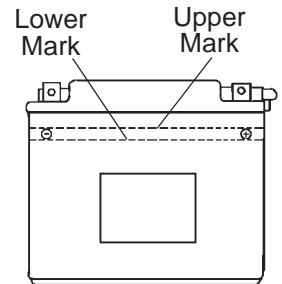

# MAINTENANCE

## Battery

### Battery Charging (Conventional Battery)

1. Remove the battery from the vehicle to prevent damage from leaking or spilled electrolyte during charging. See page 78.
2. Charge the battery with a charging output no larger than 1/10 of the battery's amp/hr rating. Charge as needed to raise the specific gravity to 1.270 or greater.
3. Reinstall the battery. See page 78. Make sure the positive terminal is toward the driver's side of the vehicle.

### Battery Charging (Sealed Battery)

The following battery charging instructions apply only to the installation of a sealed battery. Read all instructions before proceeding with the installation of this battery.

The sealed battery is already filled with electrolyte and has been sealed and *fully charged* at the factory. *Never* pry the sealing strip off or add any other fluid to this battery.

The single most important thing about maintaining a sealed battery is to keep it fully charged. Since the battery is sealed and the sealing strip cannot be removed, you must use a voltmeter or multimeter to measure DC voltage.

**WARNING!** An overheated battery may explode, causing severe injury or death. Always watch charging times carefully. Stop charging if the battery becomes very warm to the touch. Allow it to cool before resuming charging.

For a refresh charge, follow all instructions carefully.

1. Check the battery voltage with a voltmeter or multimeter. A fully charged battery will register 12.8 V or higher. If the voltage is less than 12.8 volts, recharge the battery at 1.2 amps or less until battery voltage is 12.8 or greater.
2. When using an automatic charger, refer to the charger manufacturer's instructions for recharging. When using a constant current charger, use the following guidelines for recharging.

*Always verify battery condition before and 1-2 hours after the end of charging.*

State of Charge	Voltage	Action	Charge Time (Using constant current charger @ standard amps specified on top of battery)
100%	12.8-13.0 volts	None, check at 3 mos. from date of manufacture	None required
75%-100%	12.5-12.8 volts	May need slight charge, if no charge given, check in 3 months	3-6 hours
50%-75%	12.0-12.5 volts	Needs charge	5-11 hours
25%-50%	11.5-12.0 volts	Needs charge	At least 13 hours, verify state of charge
0%-25%	11.5 volts or less	Needs charge with desulfating charger	At least 20 hours

## Cleaning and Storage

### Washing the Vehicle

Keeping your POLARIS vehicle clean will not only improve its appearance but it can also extend the life of various components.

**NOTICE:** High water pressure may damage components. POLARIS recommends washing the vehicle by hand or with a garden hose, using mild soap.

**NOTICE:** Certain products, including insect repellents and chemicals, will damage plastic surfaces. Do not allow these types of products to contact the vehicle.

The best and safest way to clean your POLARIS vehicle is with a garden hose and a pail of mild soap and water.

1. Use a professional-type washing cloth, cleaning the upper body first and the lower parts last.
2. Rinse with clean water frequently.
3. Dry surfaces with a chamois to prevent water spots.

### Washing Tips

- Avoid the use of harsh cleaners, which can scratch the finish.
- Do not use a power washer to clean the vehicle.
- Do not use medium to heavy duty compounds on the finish.
- Always use clean cloths and pads for cleaning and polishing. Old or reused cloths and pads may contain dirt particles that will scratch the finish.
- Grease all zerk fittings immediately after washing. Allow the engine to run for a while to evaporate any water that may have entered the engine or exhaust system.

If a high pressure water system is used for cleaning (not recommended), exercise extreme caution. The water may damage components and could remove paint and labels. Avoid directing the water stream at the following items:

- Wheel bearings
- Brakes
- Switches and controls
- Radiator
- Cab and body panels
- Electrical components and wiring
- Transmission seals
- Labels and decals

If an informational or graphic label becomes illegible or comes off, contact your POLARIS dealer to purchase a replacement. Replacement *safety* labels are provided by POLARIS at no charge.

### Polishing the Vehicle

POLARIS recommends the use of common household aerosol furniture polish for polishing the finish on your POLARIS vehicle. Follow the instructions on the container.

- Avoid the use of automotive products, some of which can scratch the finish of your vehicle.
- Always use clean cloths and pads for cleaning and polishing. Old or reused cloths and pads may contain dirt particles that will scratch the finish.

# MAINTENANCE

## Cleaning and Storage

### Chrome Wheel Care (if equipped)

Proper maintenance will protect chrome wheels from corrosion, preserve wheel life and ensure a “like new” appearance for many years. Chrome wheels exposed to road salt (or salt in the air in coastal areas) are more susceptible to corrosion if not properly cleaned. Clean chrome wheels more often if they're exposed to salt or other corrosive elements.

1. Wash chrome wheels frequently. Use a mild detergent. Never use abrasive cleaners on plated or painted surfaces.
2. Rinse well with clear water. Soap, detergents, salt, dirt, mud and other elements can cause corrosion.
3. Polish the clean chrome wheels periodically. Use an automotive grade chrome polish.
4. Routinely and liberally apply a weather resistant wax to each polished chrome wheel. Choose a product suitable for chrome finishes. Read and follow the product labels and instructions.

### Removing Corrosion

If light rust is found on the chrome finish, use steel wool (#0000-OTT grade) to remove it. Gently rub the affected areas with the steel wool until the corrosion has been removed. Clean and polish the wheel as outlined above.

### Storage Tips

**NOTICE:** Starting the engine during the storage period will disturb the protective film created by fogging and damage could occur. Never start the engine during the storage period.

### Clean the Exterior

Make any necessary repairs and clean the vehicle as recommended. See page 81.

### Stabilize the Fuel

1. Fill the fuel tank.
2. Add POLARIS Carbon Clean Fuel Treatment or POLARIS Fuel Stabilizer. Follow the instructions on the container for the recommended amount. Carbon Clean removes water from fuel systems, stabilizes fuel and removes carbon deposits from pistons, rings, valves and exhaust systems.
3. Allow the engine to run for 15-20 minutes to allow the stabilizer to disperse through the fuel in the tank and carburetor.
4. Drain the carburetor bowl.

### Oil and Filter

Change the oil and filter. See page 57.

### Air Filter / Air Box

1. Inspect and clean or replace the pre-cleaner and air filter. See page 67.
2. Clean the air box.
3. Drain the sediment tube.

## Cleaning and Storage

### Storage Tips

#### Inspect and Lubricate

Inspect all cables and lubricate all areas of the vehicle as recommended in the Periodic Maintenance Chart beginning on page 52.

#### Battery Maintenance

See pages 79-80 for storage and charging procedures.

#### Fluid Levels

Inspect the fluid levels. Add or change fluids as recommended in the Periodic Maintenance Chart beginning on page 52.

- Front and rear gearcase fluid (if equipped)
- Transmission fluid
- Brake fluid (change every two years and any time the fluid looks dark or contaminated)
- Coolant (test strength/fill)

#### Fog the Engine

1. Remove the spark plug and add 2-3 tablespoons (30-45 ml) of engine oil.
2. Reinstall the spark plug. Torque to specification. See page 61.
3. Apply dielectric grease to the inside of the spark plug cap. Reinstall the cap.
4. Turn the engine over several times. Oil will be forced in and around the piston rings and ring lands, coating the cylinder with a protective film of fresh oil.
5. Treat the fuel system with POLARIS Carbon Clean. See page 82. If POLARIS fuel system additive is not used, fuel tank, fuel lines, and carburetor should be completely drained of gasoline.
6. To eliminate any fuel remaining in the carburetor, run the engine until it stops.

#### Storage Area/Covers

Be sure the storage area is well ventilated. Cover the vehicle with a genuine POLARIS cover. Do not use plastic or coated materials. They do not allow enough ventilation to prevent condensation, and may promote corrosion and oxidation.

# MAINTENANCE

## Removal from Storage

1. Check the battery electrolyte level and charge the battery if necessary. Install it in the vehicle. Make sure the battery vent hose is routed properly and that it's not pinched or restricted in any way.
2. Make sure the spark plug is tight.
3. Fill the fuel tank with fuel.
4. Check all the points listed in the Daily Pre-Ride Inspection section on page 29. *Tightness of the bolts, nuts and other fasteners should be checked by an authorized POLARIS dealer.*
5. Lubricate at the intervals outlined in the Periodic Maintenance Chart beginning on page 52.

## Transporting the *RANGER*

Follow these procedures when transporting the vehicle.

1. Apply the brakes.
2. Place the transmission in PARK.
3. Stop the engine.
4. Secure the fuel cap, oil cap, hood and cargo box. Ensure that the seats are attached correctly and are not loose.

**WARNING!** Cargo and other loose vehicle parts may fly off while transporting this vehicle. Secure or remove all cargo, and inspect the unit for loose parts prior to transport.

5. Always tie the frame of the *RANGER* to the transporting unit securely with suitable straps or rope. Do not attach tie straps to the front A-arm bolt pockets.
6. Remove the key to prevent loss during transporting.

# POLARIS PRODUCTS

Part Number	Description
<b>Engine Lubricant</b>	
2870791	Fogging Oil (12 oz./355 ml Aerosol)
2876244	PS-4 Full Synthetic 5W-50 4-Cycle Oil (qt./.95 l)
2876245	PS-4 Full Synthetic 5W-50 4-Cycle Oil (gal./3.8 l)
<b>Gearcase / Transmission Lubricants</b>	
2878068	AGL Full Synthetic Gearcase Lubricant & Transmission Fluid (qt./.95 l)
2878069	AGL Full Synthetic Gearcase Lubricant & Transmission Fluid (gal./3.8 l)
2877922	Demand Drive Fluid (qt./.95 l)
2877923	Demand Drive Fluid (gal./3.8 l)
2870465	Pump for Gallon (3.8 l) Jug
<b>Coolant</b>	
2871534	Polaris Antifreeze 60/40 Premix (qt./.95 l)
2871323	Polaris Antifreeze 60/40 Premix (gal./3.8 l)
<b>Grease / Specialized Lubricants</b>	
2871312	Grease Gun Kit, All Season Grease
2871322	All Season Grease (3 oz./89 ml cartridge)
2871423	All Season Grease (14 oz./414 ml cartridge)
2876160	ATV Angle Drive Fluid (qt./.95 l)
2872276	ATV Angle Drive Fluid (2.5 gal./9.5 l)
2871460	Premium Starter Grease
2871515	U-Joint Grease (3 oz./89 ml cartridge)
2871551	U-Joint Grease (14 oz./414 ml cartridge)
2871329	Dielectric Grease (Nyogel™)
<b>Additives / Miscellaneous</b>	
2871326	Carbon Clean
2870652	Fuel Stabilizer
2872189	DOT 4 Brake Fluid
2871956	Loctite™ 565 Thread Sealant
2871076	POLARIS Battery Tender™ Charger

# SPECIFICATIONS

## RANGER 400

Maximum Weight Capacity (includes weight of operator, passenger, cargo, accessories)	1000 lbs. (454 kg)
Dry Weight	1050 lbs. (476 kg)
Test GVW - Rollover Protection System (ROPS)	2750 lbs. (1247 kg) per OSHA 29 CFR 1928.53
Fuel Capacity	8.8 gal. (33.3 l)
Engine Oil Capacity	2 qts. (1.9 l)
Coolant Capacity	2.25 qts. (2.4 l)
Overall Length	108 in. (274.3 cm)
Overall Width	56.5 in. (143.5 cm)
Overall Height	73 in. (185 cm)
Wheelbase	72 in. (183 cm)
Cargo Box Dimensions (Inside)	32 x 42 x 11.5 in. (81 x 107 x 29 cm)
Ground Clearance	10 in. (25.4 cm)
Min. Turning Radius	150 in. (381 cm)
Towing Capacity	1250 lbs. (567 kg)
Max. Cargo Box Load	500 lbs. (227 kg)
Engine	4 valve 4 stroke single cylinder with counter balance
Lubrication System	Dry Sump
Cooling	Liquid
Engine Oil	2W-50
Displacement	455 cc
Bore x Stroke (mm)	87.9 x 75
Pilot Jet	42.5
Main Jet	150
Needle Jet	P-6 (829)
Jet Needle	4IB33
Air Screw	2.75
Alternator Output	250 W
Compression Ratio	9.7:1
Starting System	Electric
Carburetor	34 mm
Ignition System	CDI
Ignition Timing	30° @5000 RPM
Spark Plug	NGK BKR6E
Front Suspension	Strut w/8 in. (20.3 cm) of travel
Rear Suspension	Independent w/9 in. (23 cm) of travel
Driving System Type	PVT
Shift Type	Single Lever (console)
Gear Reduction - Low	7.70:1
Gear Reduction - Reverse	7.00:1
Gear Reduction - High	4.12:1
Drive Ratio - Front	3.818:1



# SPECIFICATIONS

## RANGER 400

Tire Size - Front	25 x 8 - 12
Tire Size - Rear	25 x 11 - 12
Tire Pressure - Front	10 psi (68.9 kPa)
Tire Pressure - Rear	12 psi (82.7 kPa)
Brakes, Front/Rear	Foot Activated, 4 wheel hydraulic disc
Hood Headlights	2 single beam, 50W, quartz/halogen
Taillights	10 L.E.D. (.28W)
Brake Light	10 L.E.D. (3.1W)
Indicator Light	1.0 W

### Clutching Chart

Altitude		Shift Weight	Drive Spring	Driven Spring
Meters (Feet)	0-1500 (0-5000)	10 MHF PN 5632281	Blue/Red PN 7041157	Silver PN 7041499
	1500-3700 (5000-12000)	10 RH PN 5630709	Blue/Red PN 7041157	Silver PN 7041499

### Jetting Chart

Altitude Meters (Feet)	Ambient Temperature	
	Below 40° F (Below 5° C)	+40°F and above (+5°C and above)
0-1829 (0-6000)	155	<b>150</b>
1829-3048 (6000-10,000)	150	145 #2 Jet Needle Clip Position
Above 3048 (Above 10,000)	145 #2 Jet Needle Clip Position	140 #1 Jet Needle Clip Position

# TROUBLESHOOTING

## Drive Belt Wear/Burn

Possible Cause	Solution
Driving onto a pickup or tall trailer in high range	Use low range during loading.
Starting out going up a steep incline	Use low range. See warnings on page 35.
Driving at low RPM or ground speed (3-7 MPH)	Drive at a higher speed or use low range more frequently. See page 23.
Insufficient warm-up at low ambient temperatures	Warm the engine at least 5 minutes. With the transmission in neutral, advance the throttle to about 1/8 throttle in short bursts, 5 to 7 times. The belt will become more flexible and prevent belt burning.
Slow/easy clutch engagement	Use the throttle quickly and effectively.
Towing/pushing at low RPM/low ground speed	Use low range only.
Utility use/plowing	Use low range only.
Stuck in mud or snow	Shift the transmission to low range and carefully use fast, aggressive throttle application to engage clutch. <b>WARNING:</b> Excessive throttle may cause loss of control and vehicle roll-over.
Climbing over large objects from a stopped position	Shift the transmission to low range and carefully use fast, brief, aggressive throttle application to engage clutch. <b>WARNING:</b> Excessive throttle may cause loss of control and vehicle roll-over.
Belt slippage from water or snow ingestion into the PVT system	Dry out the PVT. See page 65. Inspect clutch seals for damage if repeated leaking occurs.
Clutch malfunction	See your POLARIS dealer.
Poor engine performance	Check for fouled plugs or foreign material in fuel tank or fuel lines. See your dealer.
Slippage from failure to warm up belt	Always warm up the belt by operating below 30 MPH for one mile (5 miles or more when temperature is below freezing).
Wrong or missing belt	Install the recommended belt.
Improper break-in	Always break in a new belt and/or clutch. See pages 28 and 64.

## Engine Doesn't Turn Over

Possible Cause	Solution
Low battery voltage	Recharge the battery to 12.8 VDC
Loose battery connections	Check all connections and tighten
Loose solenoid connections	Check all connections and tighten
Loose electronic control box connections	Inspect, clean, reinstall connectors

## Engine Turns Over, Fails to Start

Possible Cause	Solution
Out of fuel	Refuel
Water is present in fuel	Drain the fuel system and refuel
Old or non-recommended fuel	Replace with fresh recommended fuel
Fouled or defective spark plugs	Inspect plugs and replace if necessary
No spark to spark plug	Inspect plugs and replace if necessary
Water or fuel in crankcase	Immediately see your POLARIS dealer
Overuse of choke	Inspect, clean and/or replace spark plug
Low battery voltage	Recharge the battery to 12.8 VDC
Mechanical failure	See your dealer

## Engine Backfires

Possible Cause	Solution
Weak spark from spark plug	Inspect, clean and/or replace spark plugs
Incorrect spark plug gap or heat range	Set gap to specs or replace plugs
Old or non-recommended fuel	Replace with fresh recommended fuel
Incorrectly installed spark plug wires	See your dealer
Incorrect ignition timing	See your dealer
Mechanical failure	See your dealer
Loose ignition connections	Check all connections and tighten
Water present in fuel	Replace with fresh recommended fuel

# TROUBLESHOOTING

## Engine Pings or Knocks

Possible Cause	Solution
Poor quality or low octane fuel	Replace with recommended fuel
Incorrect ignition timing	See your dealer
Incorrect spark plug gap or heat range	Set gap to specs or replace plugs

## Engine Runs Irregularly, Stalls or Misfires

Possible Cause	Solution
Fouled or defective spark plugs	Inspect, clean and/or replace spark plugs
Worn or defective spark plug wires	See your dealer
Incorrect spark plug gap or heat range	Set gap to specs or replace plugs
Loose ignition connections	Check all connections and tighten
Water present in fuel	Replace with new fuel
Low battery voltage	Recharge battery to 12.8 VDC
Kinked or plugged fuel tank vent line	Inspect and replace
Incorrect fuel	Replace with recommended fuel
Clogged air filter	Inspect and clean or replace
Other mechanical failure	See your dealer

Possible Lean Fuel Cause	Solution
Overuse of choke	Inspect, clean and/or replace spark plug
Low or contaminated fuel	Add or change fuel, clean the fuel system
Low octane fuel	Replace with recommended fuel
Possible Rich Fuel Cause	Solution
Fuel is very high octane	Replace with lower octane fuel

## Engine Stops or Loses Power

Possible Cause	Solution
Out of fuel	Refuel
Kinked or plugged fuel vent line	Inspect and replace
Overuse of choke	Inspect, clean and/or replace spark plug
Water is present in fuel	Replace with new fuel
Fouled or defective spark plugs	Inspect, clean and/or replace spark plug
Worn or defective spark plug wires	See your dealer
Incorrect spark plug gap or heat range	Set gap to specs or replace plug
Loose ignition connections	Check all connections and tighten
Low battery voltage	Recharge the battery to 12.8 VDC
Incorrect fuel	Replace with fresh recommended fuel
Clogged air filter	Inspect and clean or replace
Other mechanical failure	See your dealer
Overheated engine	Clean radiator screen and core, clean engine exterior, see your dealer

# WARRANTY

## LIMITED WARRANTY

POLARIS Sales Inc., 2100 Highway 55, Medina, MN 55340 (POLARIS) gives a SIX MONTH LIMITED WARRANTY on all components of your POLARIS vehicle against defects in material or workmanship. POLARIS further warrants that the spark arrestor in this product will meet the efficiency requirements of USFS standard 5100-1C for at least 1000 hours when subjected to normal use and when maintenance and installation are in accordance with POLARIS recommendations.

This warranty covers parts and labor charges for repair or replacement of defective parts and begins on the date of purchase by the original retail purchaser. This warranty is transferable to another owner during the warranty period through a POLARIS dealer, but any such transfer will not extend the original term of the warranty. The duration of this warranty may vary by international region based upon local laws and regulations.

## REGISTRATION

At the time of sale, the Warranty Registration Form must be completed by your dealer and submitted to POLARIS within ten days of purchase. Upon receipt of this registration, POLARIS will record the registration for warranty. No verification of registration will be sent to the purchaser as the copy of the Warranty Registration Form will be your proof of warranty coverage. If you have not signed the original registration and received the customer copy, please contact your dealer immediately. **NO WARRANTY COVERAGE WILL BE ALLOWED UNLESS YOUR VEHICLE IS REGISTERED WITH POLARIS.** Initial dealer preparation and set-up of your vehicle is very important in ensuring trouble-free operation. Purchasing a machine in the crate or without proper dealer set-up will void your warranty coverage.

## WARRANTY COVERAGE AND EXCLUSIONS: LIMITATIONS OF WARRANTIES AND REMEDIES

This POLARIS limited warranty excludes any failures that are not caused by a defect in material or workmanship. **THIS WARRANTY DOES NOT COVER CLAIMS OF DEFECTIVE DESIGN.** This warranty also does not cover acts of God, accidental damage, normal wear and tear, abuse or improper handling. This warranty also does not cover any vehicle, component, or part that has been altered structurally, modified, neglected, improperly maintained, or used for purposes other than for which it was designed.

This warranty excludes damages or failures resulting from: improper lubrication; improper engine timing; improper fuel; surface imperfections caused by external stress, heat, cold or contamination; operator error or abuse; improper component alignment, tension, adjustment or altitude compensation; snow, water, dirt or other foreign substance ingestion/contamination; improper maintenance; modified components; use of aftermarket or unapproved components, accessories, or attachments; unauthorized repairs; or repairs made after the warranty period expires or by an unauthorized repair center.

## LIMITATIONS OF WARRANTIES AND REMEDIES

This warranty excludes damages or failures caused by abuse, accident, fire, or any other cause other than a defect in materials or workmanship and provides no coverage for consumable components, general wear items, or any parts exposed to friction surfaces, stresses, environmental conditions and/or contamination for which they were not designed or not intended, including but not limited to the following items:

- Wheels and tires
- Suspension components
- Brake components
- Seat components
- Clutches and components
- Steering components
- Batteries
- Light bulbs/Sealed beam lamps
- Filter
- Lubricants
- Bushings
- Finished and unfinished surfaces
- Carburetor/Throttle body components
- Engine components
- Drive belts
- Hydraulic components and fluids
- Circuit breakers/Fuses
- Electronic components
- Spark plugs
- Sealants
- Coolants
- Bearings

## Lubricants and Fluids

1. Mixing oil brands or using non-recommended oil may cause engine damage. We recommend the use of POLARIS engine oil.

2. Damage or failure resulting from the use of non-recommended lubricants or fluids is not covered by this warranty.

This warranty provides no coverage for personal loss or expense, including mileage, transportation costs, hotels, meals, shipping or handling fees, product pick-up or delivery, replacement rentals, loss of product use, loss of profits, or loss of vacation or personal time.

THE EXCLUSIVE REMEDY FOR BREACH OF THIS WARRANTY SHALL BE, AT POLARIS' OPTION, REPAIR OR REPLACEMENT OF ANY DEFECTIVE MATERIALS, COMPONENTS, OR PRODUCTS. THE REMEDIES SET FORTH IN THIS WARRANTY ARE THE ONLY REMEDIES AVAILABLE TO ANY PERSON FOR BREACH OF THIS WARRANTY. POLARIS SHALL HAVE NO LIABILITY TO ANY PERSON FOR INCIDENTAL, CONSEQUENTIAL OR SPECIAL DAMAGES OF ANY DESCRIPTION, WHETHER ARISING OUT OF EXPRESS OR IMPLIED WARRANTY OR ANY OTHER CONTRACT, NEGLIGENCE, OR OTHER TORT OR OTHERWISE. THIS EXCLUSION OF CONSEQUENTIAL, INCIDENTAL, AND SPECIAL DAMAGES IS INDEPENDENT FROM AND SHALL SURVIVE ANY FINDING THAT THE EXCLUSIVE REMEDY FAILED OF ITS ESSENTIAL PURPOSE.

THE IMPLIED WARRANTY OF FITNESS FOR A PARTICULAR PURPOSE IS EXCLUDED FROM THIS LIMITED WARRANTY. ALL OTHER IMPLIED WARRANTIES (INCLUDING BUT NOT LIMITED TO THE IMPLIED WARRANTY OF MERCHANTABILITY) ARE LIMITED IN DURATION TO THE ABOVE SIX MONTH WARRANTY PERIOD. POLARIS DISCLAIMS ALL EXPRESS WARRANTIES NOT STATED IN THIS WARRANTY. SOME STATES DO NOT PERMIT THE EXCLUSION OR LIMITATION OF INCIDENTAL OR CONSEQUENTIAL DAMAGES OR ALLOW LIMITATIONS ON THE DURATION OF IMPLIED WARRANTIES, SO THE ABOVE LIMITATIONS MAY NOT APPLY TO YOU IF INCONSISTENT WITH CONTROLLING STATE LAW.

# WARRANTY

## HOW TO OBTAIN WARRANTY SERVICE

If your vehicle requires warranty service, you must take it to a POLARIS Servicing Dealer. When requesting warranty service you must present your copy of the Warranty Registration Form to the dealer. (THE COST OF TRANSPORTATION TO AND FROM THE DEALER IS YOUR RESPONSIBILITY). POLARIS suggests that you use your original selling dealer; however, you may use any POLARIS Servicing Dealer to perform warranty service.

*In the country where your product was purchased:*

Warranty or Service Bulletin repairs must be done by an authorized POLARIS dealer. If you move or are traveling within the country where your product was purchased, Warranty and Service Bulletin repairs may be requested from any authorized POLARIS dealer that sells the same line as your product.

*Outside the country where your product was purchased:*

If you are traveling temporarily outside the country where your product was purchased, you should take your product to an authorized POLARIS dealer. You must show the dealer photo identification from the country of the selling dealer's authorized location as proof of residence. Upon residence verification, the servicing dealer will be authorized to perform the warranty repair.

*If you move:*

If you move to another country, be sure to contact POLARIS Customer Assistance and the customs department of the destination country before you move. Product importation rules vary considerably from country to country. You may be required to present documentation of your move to POLARIS in order to continue your warranty coverage. You may also be required to obtain documentation from POLARIS in order to register your product in your new country. You should warranty register your product at a local POLARIS dealer in your new country immediately after you move to continue your warranty coverage and to ensure that you receive information and notices regarding your vehicle.

*If you purchase from a private party:*

If you purchase a POLARIS product from a private party, to be kept and used outside of the country in which the product was originally purchased, all warranty coverage will be denied. You must nonetheless register your product under your name and address with a local POLARIS dealer in your country to ensure that you receive safety information and notices regarding your product.



## EXPORTED PRODUCTS

EXCEPT WHERE SPECIFICALLY REQUIRED BY LAW, THERE IS NO WARRANTY OR SERVICE BULLETIN COVERAGE ON THIS PRODUCT IF IT IS SOLD OUTSIDE THE COUNTRY OF THE SELLING DEALER'S AUTHORIZED LOCATION. This policy does not apply to products that have received authorization for export from POLARIS. Dealers may not give authorization for export. You should consult an authorized dealer to determine this product's warranty or service coverage if you have any questions. This policy does not apply to products registered to government officials or military personnel on assignment outside the country of the selling dealer's authorized location. This policy does not apply to Safety Bulletins.

## NOTICE

If your product is registered outside of the country where it was purchased and you have not followed the procedure set above, your product will no longer be eligible for warranty or service bulletin coverage of any kind, other than *safety* bulletins. Products registered to Government officials or military personnel on assignment outside of the country where the product was purchased will continue to be covered by the Limited Warranty.

Please work with your dealer to resolve any warranty issues. Should your dealer require any additional assistance, they will contact the appropriate person at POLARIS.

This warranty gives you specific legal rights, and you may also have other rights which vary from state to state or in different countries. If any of the above terms are void because of federal, state, local law, all other warranty terms will remain in effect.

***For questions call POLARIS Customer Assistance:***

United States & Canada: 1-800-POLARIS (1-800-765-2747)

French: 1-800-268-6334

# WARRANTY

## U.S.A. EPA Emissions Limited Warranty

This emissions limited warranty is in addition to the POLARIS standard limited warranty for your vehicle. POLARIS Industries Inc. warrants that at the time it is first purchased, this emissions-certified vehicle is designed, built and equipped so it conforms with applicable U.S. Environmental Protection Agency emission regulations. POLARIS warrants that the vehicle is free from defects in materials and workmanship that would cause it to fail to meet these regulations.

The warranty period for off-road vehicles 100cc or greater emissions-certified vehicles starts on the date of purchase by original retail purchaser and continues for a period of 500 hours of engine operation, 5000 kilometers (3100 miles) of vehicle travel, or 30 calendar months from the date of purchase, whichever comes first. The warranty period for ATVs less than 100cc emissions-certified vehicles starts on the date of purchase by original retail purchaser and continues for a period of 250 hours of engine operation, 2500 kilometers (3100 miles) of vehicle travel, or 30 calendar months from the date of purchase, whichever comes first. This EPA emissions warranty period is extended for at least as long as the standard factory warranty that Polaris provides on the vehicle as a whole. The EPA emissions warranty period does not further extend if you purchase additional warranty coverage in the form of a service contract or other paid warranty extension, but emission-related parts may be covered subject to the terms of any such paid service contract or paid warranty extension.

This emissions limited warranty covers components whose failure increases the vehicle's regulated emissions, and it covers components of systems whose only purpose is to control emissions. Repairing or replacing other components not covered by this warranty is the responsibility of the vehicle owner. This emissions limited warranty does not cover components whose failure does not increase the vehicle's regulated emissions.

For exhaust emissions, emission-related components include any engine parts related to the following systems:

- Air-induction system
- Fuel system
- Ignition system
- Exhaust gas recirculation systems

The following parts are also considered emission-related components for exhaust emissions:

- Aftertreatment devices
- Crankcase ventilation valves
- Sensors
- Electronic control units

The following parts are considered emission-related components for evaporative emissions:

- Fuel Tank
- Fuel Cap
- Fuel Line
- Fuel Line Fittings
- Clamps\*
- Pressure Relief Valves\*
- Control Valves\*
- Control Solenoids\*
- Electronic Controls\*
- Vacuum Control Diaphragms\*
- Control Cables\*
- Control Linkages\*
- Purge Valves
- Vapor Hoses
- Liquid/Vapor Separator
- Carbon Canister
- Canister Mounting Brackets
- Carburetor Purge Port Connector

\*As related to the evaporative emission control system.

# WARRANTY

## U.S.A. EPA Emissions Limited Warranty

The exclusive remedy for breach of this limited warranty shall be, at the exclusive option of POLARIS, repair or replacement of any defective materials, components or products. THE REMEDIES SET FORTH IN THIS LIMITED WARRANTY ARE THE ONLY REMEDIES AVAILABLE TO ANY PERSON FOR BREACH OF THIS WARRANTY. POLARIS SHALL HAVE NO LIABILITY TO ANY PERSON FOR INCIDENTAL, CONSEQUENTIAL OR SPECIAL DAMAGES OF ANY DESCRIPTION, WHETHER ARISING OUT OF EXPRESS OR IMPLIED WARRANTY OR ANY OTHER CONTRACT, NEGLIGENCE OR OTHER TORT OR OTHERWISE. THIS EXCLUSION OF CONSEQUENTIAL, INCIDENTAL, AND SPECIAL DAMAGES IS INDEPENDENT FROM AND SHALL SURVIVE ANY FINDING THAT THE EXCLUSIVE REMEDY FAILED OF ITS ESSENTIAL PURPOSE.

ALL IMPLIED WARRANTIES (INCLUDING BUT NOT LIMITED TO ANY IMPLIED WARRANTIES OF MERCHANTABILITY AND FITNESS FOR A PARTICULAR PURPOSE) ARE LIMITED IN DURATION TO THE WARRANTY PERIOD DESCRIBED HEREIN. POLARIS DISCLAIMS ALL EXPRESS WARRANTIES NOT STATED IN THIS WARRANTY. Some states do not allow limitations on how long an implied warranty lasts, so the above limitation may not apply if it is inconsistent with the controlling state law.

This limited warranty excludes failures not caused by a defect in material or workmanship. This limited warranty does not cover damage due to accidents, abuse or improper handling, maintenance or use. This limited warranty also does not cover any engine that has been structurally altered, or when the vehicle has been used in racing competition. This limited warranty also does not cover physical damage, corrosion or defects caused by fire, explosions or other similar causes beyond the control of POLARIS.

Owners are responsible for performing the scheduled maintenance identified in the owner's manual. POLARIS may deny warranty claims for failures that have been caused by the owner's or operator's improper maintenance or use, by accidents for which POLARIS has no responsibility, or by acts of God.

Any qualified repair shop or person may maintain, replace, or repair the emission control devices or systems on your vehicle. POLARIS recommends that you contact an authorized POLARIS dealer to perform any service that may be necessary for your vehicle. POLARIS also recommends that you use only Pure POLARIS parts. It is a potential violation of the Clean Air Act if a part supplied by an aftermarket parts manufacturer reduces the effectiveness of the vehicle's emission controls. Tampering with emission controls is prohibited by federal law.

## California Residents

Certain POLARIS off-road vehicles are available in 49-state and 50-state versions. Only the 50-state models are certified for sale in California. The 50-state models available for sale in California are identified by the letter "C" in the model name (e.g., R13UH88A\_C). The POLARIS 50-state models are designed and built with features such as a reduced cargo box capacity. Any modifications to these features may be a violation of the applicable California regulations and may void this limited emissions warranty offered by the manufacturer.

If you have any questions regarding your warranty rights and responsibilities, please contact POLARIS Customer Assistance.

United States & Canada: 1-800-POLARIS (1-800-765-2747)

French: 1-800-268-6334







# INDEX

## A

Accessory Outlet	22
Air Filter	67
All Wheel Drive	41
All Wheel Drive Lock Switch	24
Auxiliary Outlet	22
AWD	41
AWD/Differential Lock Switch	24
Axle Nut Torque	73

## B

<b>Battery</b>	<b>77-80</b>
Charging (Conventional)	80
Charging (Sealed)	80
Fluid Replenishment	79
Installation	78
Removal	78
Storage	79
Warnings	77
Belt Life	38
Belt Replacement	64
Belt Wear	88
Boots	9
Brake Fluid	71
Brake Inspection	71
Brake Lights	76
Brake Pedal	23
Brakes	71
Braking	31
Break-In Period	28
Breather Filter	67

## C

Cab Frame, ROPS	25
Cab Nets	27
Carburetor	68
Carburetor Adjustment	68
Cargo	37
Cargo Box, Dumping	39
Chrome Wheel Care	82
Cleaning and Storage	81-83
Clothing	9
Clutching	87
Component Locations	21-23
Coolant Level, Overflow Bottle	63
Coolant Level, Radiator	63
Coolant, Adding or Changing	62
Cooling Fan	62
Cooling System	62-63
Corrosion Removal, Chrome	82
Cylinder Head Fasteners	66

## D

Differential Lock Switch	24
Differential Operation	40
Disengaging AWD	41
Drive Belt Wear	88
Drivetrain Break-In	28
Driving Downhill	35
Driving in Reverse	33
Driving on a Sidehill	35
Driving on Slippery Surfaces	34
Driving Over Obstacles	33
Driving Procedure	31
Driving Through Water	36
Driving Uphill	35
Driving with a Passenger	32
Driving, After Driving in Water	65
Dumping the Cargo Box	39

## E

Emissions Limited Warranty	96-97
Engine Break-In	28
Engine Fogging	83
Engine Idle RPM Adjustment	68
Engine Oil	56-58
Engine Starting	30
Engine Stopping	31
Equipment Modifications	15
Exhaust System Warning	69
Eye Protection	9

## F

Fastener Torque, Cylinder Head/Base	66
Filter Change	57-58
Filter Systems	67
Filter, Air	67
Filter, Breather	67
Filter, Fuel	67
<b>Fluid Change</b>	
Engine Oil	57-58
Front Gearcase	60
Main Gearcase	59
Transmission	59
<b>Fluid Level</b>	
Coolant (Overflow Bottle)	63
Coolant (Radiator)	63
Engine Oil	56
Front Gearcase	60
Main Gearcase	59
Transmission	59
Fluid Levels During Storage	83
<b>Fluid Recommendation</b>	
Coolant	62
Engine Oil	56
Gearcases	59

# INDEX

## F

Fluid, Battery . . . . .	79
Fluid, Brake . . . . .	71
Fogging the Engine . . . . .	83
Fouled Plugs . . . . .	61
Freeplay Adjustment, Throttle . . . . .	70
Freeplay Inspection, Throttle . . . . .	70
Freeplay, Throttle . . . . .	70
Front Gearcase . . . . .	60
Fuel Cap . . . . .	25
Fuel Filter . . . . .	67
Fuel Safety . . . . .	18
Fuel Stabilizer . . . . .	82

## G

Gap, Spark Plug . . . . .	61
Gasoline Handling . . . . .	18
Gear Selector . . . . .	23
Gearcase Specification Chart . . . . .	59
Gearcase, Front . . . . .	60
Gearcase, Main . . . . .	59
Gearcases . . . . .	59-60
Gears, Shifting . . . . .	23
Gloves . . . . .	9

## H

Hauling Cargo . . . . .	37
Headlight Beam Adjustment . . . . .	75
Headlight Lamp Replacement . . . . .	76
Helmet . . . . .	8
Hitch Bracket . . . . .	25
Hitch Weight . . . . .	38

## I

Idle RPM Adjustment . . . . .	68
Ignition Switch . . . . .	24
Immersion of Vehicle . . . . .	66
Indicator Light Replacement . . . . .	76
Indicator Lights . . . . .	22

## K

Key, Periodic Maintenance Chart . . . . .	52
---	----

## L

Lamp Replacement, Indicator Lights . . . . .	76
Light Switch . . . . .	24
<b>Lights</b>	
Brake Lights . . . . .	76
Headlight Beam Adjustment . . . . .	75
Headlight Lamp Replacement . . . . .	76
Indicator Lamp Replacement . . . . .	76
Indicator Lights . . . . .	22
Lubrication Recommendations . . . . .	55

## M

Main Gearcase . . . . .	59
Maintenance Log . . . . .	98
Maintenance, Periodic . . . . .	52-54
Modifications . . . . .	15

## O

Obstacles . . . . .	33
Oil, Engine . . . . .	56-58
<b>Oil Change</b>	
Engine Oil . . . . .	57-58
Front Gearcase . . . . .	60
Main Gearcase . . . . .	59
Transmission . . . . .	59
<b>Oil Level</b>	
Engine Oil . . . . .	56
Front Gearcase . . . . .	60
Main Gearcase . . . . .	59
Transmission . . . . .	59
Oil Pump Priming . . . . .	58
Oil Recommendations . . . . .	56
Operator Safety . . . . .	13-20
Outlet, Auxiliary . . . . .	22

## P

Parking on an Incline . . . . .	36
Parking the Vehicle . . . . .	32
Periodic Maintenance Chart . . . . .	52-54
Plug Gap . . . . .	61
Plug Torque . . . . .	61
Plug, Accessory . . . . .	22
Plugs, Fouled . . . . .	61



## P

Polaris Products .....	85
Polishing the Vehicle .....	81
Pre-Ride Inspection .....	29
Pressure, Tire .....	12
PVT Break-In .....	28
PVT Drying .....	65
PVT System .....	64-65
PVT Warning .....	65
PVT, Cleaning Debris .....	64

## R

Radiator .....	62
Radiator Coolant Level .....	63
Reverse Operator .....	33
Riding Gear .....	8-9
Roll-Over Protection System .....	25
ROPS Cab Frame .....	25

## S

Safety Labels .....	10-11
Safety Symbols .....	4
Safety, Winch Maintenance .....	50
Seat Belt Inspection .....	26
Seat Belts .....	26
Seat Removal .....	27
Severe Use Definition .....	52
Shifter .....	23
Shifting Gears .....	23
Shock Loading the Winch .....	49
Shock Spring Adjustment .....	72
Signal Words .....	4
Spark Arrester .....	69
Spark Arrester Warning .....	69
Spark Plug Gap .....	61
Spark Plug Inspection .....	61
Spark Plug Recommendations .....	61
Spark Plug Torque .....	61
Spark Plugs .....	61
Spark Plugs, Fouled .....	61
Specifications .....	86-87
Specifications, Gearcase .....	59
Speed, Towing .....	38
Starting the Engine .....	30
Steering Wheel Inspection .....	72
Stopping the Engine .....	31
Storage .....	81-83
Storage Area .....	83
Storage Tips .....	82-83
Storage, Battery .....	79
Storage, Covers .....	83

## S

Storage, Removal From .....	84
-----------------------------	----

### Switches

AWD Switch .....	24
Differential Lock Switch .....	24
Ignition Switch .....	24
Light Switch .....	24

## T

Throttle Freeplay .....	70
Throttle Freeplay Adjustment .....	70
Throttle Freeplay Inspection .....	70
Throttle Pedal .....	23
Throttle System .....	70
Tire Pressure .....	12
<b>Tires .....</b>	<b>73-74</b>
Nut Torque .....	73
Tread Depth .....	73
Wheel Installation .....	74
Wheel Removal .....	74
Towing Loads .....	38
Towing Speed .....	38
Trailer Hitch Bracket .....	25
Transmission .....	59
Transmission Operation .....	65
Transmission System .....	64-65
Transmission Warning .....	65
Transmission, Drying .....	65
Transporting the Vehicle .....	84

## V

Vehicle Identification Numbers .....	6
Vehicle Immersion .....	66
Vehicle Transport .....	84

## W

Warning Symbols .....	4
Warning, Transmission Modification .....	65
Washing the Vehicle .....	81
Weight, Hitch .....	38
Wheel Installation .....	74
Wheel Nut Torque .....	73
Wheel Removal .....	74
Winch Cable Care .....	48
Winch Maintenance and Service Safety .....	50
Winch Operation .....	44-47
Winch Safety Precautions .....	42-43
Winch Shock Loading .....	49

# ! WARNING

Improper vehicle use can result in SEVERE INJURY or DEATH

## NEVER Operate:

- If you are under age 16 and without a valid driver's license.
- Without first viewing safety video and taking a ROHVA training course at [www.rohva.org](http://www.rohva.org).
- On excessively steep hills.
- On public roads (unless designated for off-road use).
- With a passenger who is not seated in a passenger seat, or with passengers under age 12 or who cannot comfortably reach the floor and hand holds.
- On paved surfaces - pavement may seriously affect handling and control.
- With non-Polaris approved accessories - they may seriously affect stability.

## ALWAYS:

- Wear your seat belt. Vehicle rollover can cause severe injury or death.
- Secure cab nets or doors and keep hands and feet inside vehicle at all times.
- Wear a helmet, eye protection, gloves, long-sleeve shirt, long pants and over-the-ankle boots.
- Reduce speed and use extra caution when carrying passengers.
- Avoid sharp turns or turns while applying heavy throttle.
- Operate slowly in reverse - avoid sharp turns or sudden braking.
- Make sure passengers read and understand all safety labels.



ALL RIDERS MUST WEAR AN APPROVED HELMET AND PROTECTIVE GEAR.  
ALL RIDERS MUST WEAR SEAT BELTS. NEVER USE ON PUBLIC ROADS.  
NEVER USE WITH DRUGS OR ALCOHOL.

READ OWNER'S MANUAL. FOLLOW ALL INSTRUCTIONS AND WARNINGS.



For your nearest Polaris dealer,  
call 1-800-POLARIS  
or visit [www.polaris.com](http://www.polaris.com)  
Polaris Sales Inc.  
2100 Hwy. 55  
Medina, MN 55340  
Phone 1-888-704-5290  
Part No. 9924302 Rev 01  
Printed in USA

