



BRUTUS[®] **SNOW BLADE**

Owner's Manual
for Maintenance and Safety

WELCOME

Thank you for purchasing a POLARIS vehicle, and welcome to our world-wide family of POLARIS owners. We proudly produce an exciting line of utility and recreational products.

- Snowmobiles
- All-terrain vehicles (ATVs)
- BRUTUS® utility vehicles and attachments
- RANGER® utility vehicles
- Victory® motorcycles
- Low Emission Vehicles (LEVs)

We believe POLARIS sets a standard of excellence for all utility and recreational vehicles manufactured in the world today. Many years of experience have gone into the engineering, design, and development of your POLARIS vehicle, making it the finest machine we've ever produced.

For safe and enjoyable operation of your vehicle, be sure to follow the instructions and recommendations in this owner's manual. Your manual contains instructions for minor maintenance, but information about major repairs is outlined in the POLARIS Service Manual and should be performed only by a Factory Certified Master Service Dealer® (MSD) Technician.

Your POLARIS dealer knows your vehicle best and is interested in your total satisfaction. Be sure to return to your dealership for all of your service needs during, and after, the warranty period.



POLARIS® and BRUTUS® are trademarks of POLARIS Industries Inc.

Copyright 2013 POLARIS Industries Inc. All information contained within this publication is based on the latest product information at the time of publication. Due to constant improvements in the design and quality of production components, some minor discrepancies may result between the actual vehicle and the information presented in this publication. Depictions and/or procedures in this publication are intended for reference use only. No liability can be accepted for omissions or inaccuracies. Any reprinting or reuse of the depictions and/or procedures contained within, whether whole or in part, is expressly prohibited.

The original instructions for this vehicle are in English. Other languages are provided as translations of the original instructions.

Printed in U.S.A.

BRUTUS Snow Blade Owner's Manual

P/N 9924406

TABLE OF CONTENTS

Introduction	4
Safety	6
Features And Accessories	11
Initial Setup	13
Daily Inspection	14
Operation	15
Lifting The Attachment	26
Transporting The Attachment On A Trailer	26
Maintenance Safety	28
Troubleshooting	29
Maintenance	30
POLARIS Products	42
Specifications	43
Bolt Torque	46
Hydraulic Connection Specifications	47
Warranty	48
Maintenance Log	49
Index	51

INTRODUCTION

⚠ WARNING

Failure to follow the warnings contained in this manual can result in severe injury or death.

A POLARIS BRUTUS and attachments are not toys and can be hazardous to operate. This vehicle handles differently than other vehicles, such as motorcycles and cars. A collision or rollover can occur quickly, even during routine maneuvers like turning, or driving on hills or over obstacles, if you fail to take proper precautions.

- Read this owner's manual. Understand all safety warnings, precautions and operating procedures before operating the vehicle. Keep this manual with the vehicle.
- Never permit a guest to operate this vehicle unless the guest has read this manual and all product labels.
- Always keep hands and feet inside the vehicle at all times.
- The Polaris BRUTUS is not intended for on-highway use. Driver must be at least 16 years old with a valid driver's license to operate. Passengers must be at least 12 years old and tall enough to sit with feet firmly on the floor. All SxS drivers should take a safety training course. Polaris recommends that drivers and passengers wear helmets, eye protection, and protective clothing, especially for trail riding and other recreational use. Always wear seat belts. Be particularly careful on difficult terrain. Never engage in stunt driving, and avoid excessive speeds and sharp turns. Riding and alcohol/drugs don't mix. Check local laws before riding trails.

The BRUTUS is an off-road vehicle. Familiarize yourself with all laws and regulations concerning the operation of this vehicle in your area.

The following signal words and symbols appear throughout this manual and on your vehicle. Your safety is involved when these words and symbols are used. Become familiar with their meanings before reading the manual.

Safety Symbols and Signal Words

The following signal words and symbols appear throughout this manual. Your safety and the safety of others is involved when these words and symbols are used. Become familiar with their meanings before reading the manual.



The safety alert symbol indicates a potential personal injury hazard.

DANGER

A DANGER indicates a hazardous situation that, if not avoided, will result in death or serious injury.

WARNING

A WARNING indicates a hazardous situation that, if not avoided, could result in death or serious injury.

CAUTION

A CAUTION indicates a hazardous situation that, if not avoided, could result in minor or moderate injury.

NOTICE

A NOTICE indicates a situation that could result in property damage.



The Prohibition Safety Sign indicates an action NOT to take in order to avoid a hazard.



The Mandatory Action Sign indicates an action that NEEDS to be taken to avoid a hazard.

Vehicle Identification Numbers

Record your snow blade identification number in the spaces provided.

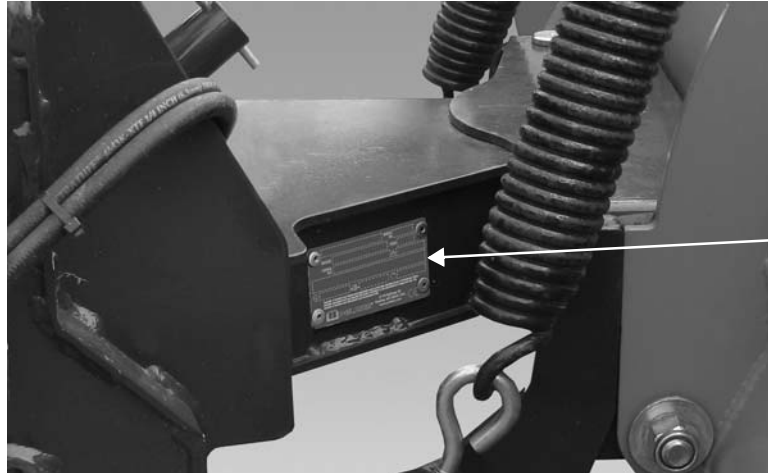

VIN

Vehicle Model Number: _____

SAFETY

Safety Labels and Locations

Warning labels have been placed on the vehicle for your protection. Read and follow the instructions of the labels on the vehicle carefully. If any of the labels depicted in this manual differ from the labels on your vehicle, always read and follow the instructions of the labels *on the vehicle*.

If any label becomes illegible or comes off, contact your POLARIS dealer to purchase a replacement. Replacement *safety* labels are provided by POLARIS at no charge. The part number is printed on the label.

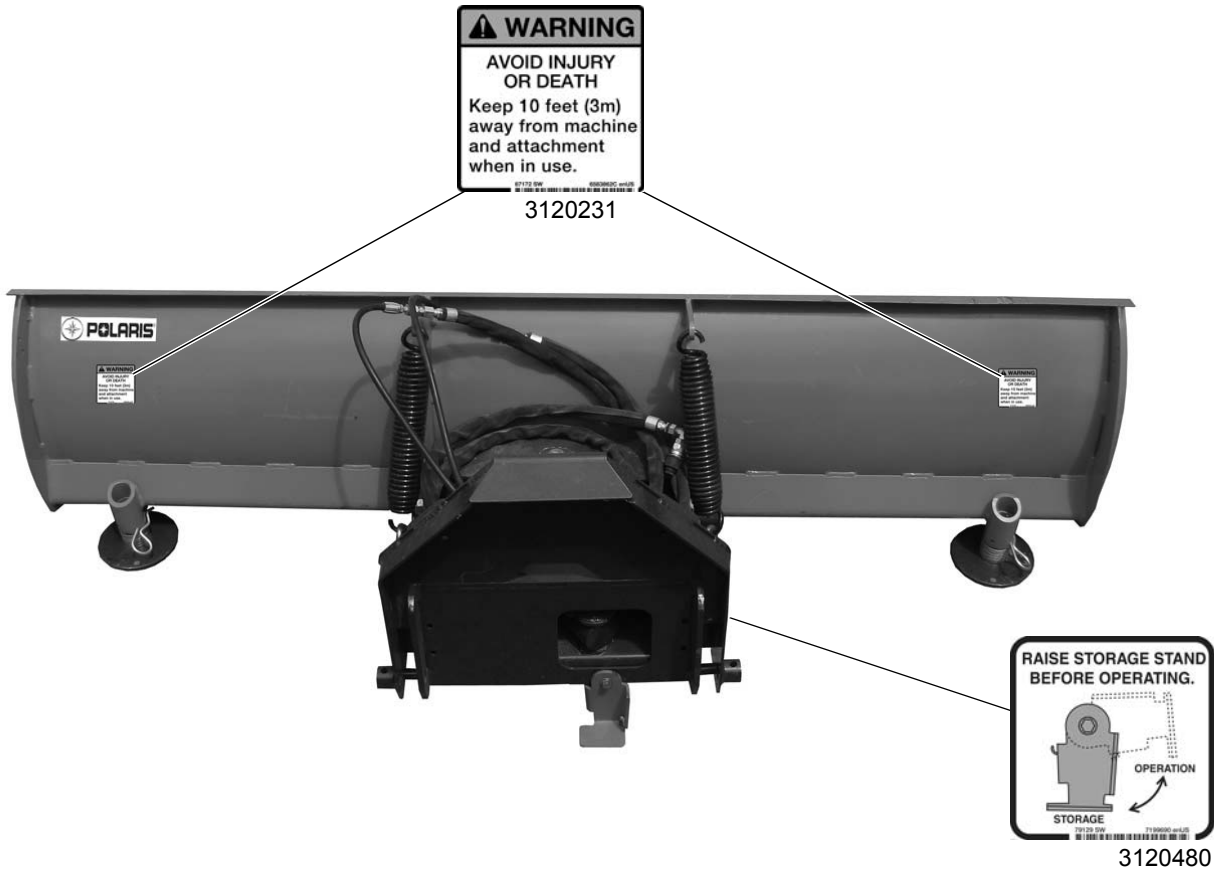

Safety Labels and Locations

Keep Away Danger

DANGER

AVOID INJURY OR DEATH

- Keep 10 feet (3 m) away from machine and attachment when in use.

3120231

Raise Storage Stand Before Operating

3120480

SAFETY

Operator Safety

WARNING!

Serious injury or death can result if you do not follow these instructions and procedures, which are outlined in further detail within your owner's manual.

- Read this manual and all labels carefully. Follow the operating procedures described.
- Never allow anyone under age 16 to operate this vehicle and never allow anyone without a valid driver's license to operate this vehicle.
- Do not carry passengers until you have at least two hours of driving experience with this vehicle.
- No person under the age of 12 may ride as a passenger in this vehicle. Any passenger must be able to comfortably reach the floor and hand holds.
- The driver and all passengers must wear eye protection and seat belt at all times. All riders should also wear long sleeves, long pants and sturdy over-the-ankle boots.
- Always keep hands and feet inside the vehicle at all times.
- Always keep both hands on the steering wheel and both feet on the floorboards of the vehicle during operation.
- Never permit a guest to operate this vehicle unless the guest has read this manual and all product labels.
- To reduce tipover risk, be especially careful when encountering obstacles and slopes and when braking on hills or during turns.
- This vehicle is for off road use only. Never operate on public roads. Always avoid paved surfaces.
- Never consume alcohol or drugs before or while operating this vehicle.
- Never operate at excessive speeds. Always travel at a speed proper for the terrain, visibility and operating conditions, and your experience.
- Never attempt jumps or other stunts.
- Always inspect the vehicle before each use to make sure it's in safe operating condition. Always follow the inspection procedures described in this manual.
- Always travel slowly and use extra caution when operating on unfamiliar terrain. Be alert to changing terrain.
- Never operate on excessively rough, slippery or loose terrain.
- Always follow proper procedures for turning. Practice turning at slow speeds before attempting to turn at faster speeds. Never turn at excessive speeds.
- Always have this vehicle checked by an authorized POLARIS dealer if it has been involved in an accident.
- Never operate this vehicle on hills too steep for the vehicle or for your abilities. Practice on smaller hills before attempting larger hills.
- Always follow proper procedures for climbing hills as described in the BRUTUS owner's manual. Check the terrain carefully before attempting to climb a hill. Never climb hills with excessively slippery or loose surfaces. Never move the travel control pedal suddenly, make sudden changes of direction or make sudden gear changes. Never go over the top of a hill at high speed.
- Always follow the proper procedures outlined in this manual for traveling downhill and for braking on hills. Check the terrain carefully before descending a hill. Never travel downhill at high speed. Avoid going downhill at an angle, which would cause the vehicle to lean sharply to one side. Travel straight down the hill where possible.
- Always check for obstacles before operating in a new area. Never attempt to operate over large obstacles such as rocks or fallen trees. Always follow the proper procedures outlined in the BRUTUS owner's manual when operating over obstacles.
- Always be careful of skidding or sliding. On slippery surfaces such as ice, travel slowly and exercise caution to reduce the chance of skidding or sliding out of control.
- Never operate your vehicle in fast-flowing water or in water deeper than that specified in the BRUTUS owner's manual. Wet brakes may have reduced stopping ability. Test your brakes after leaving water. If necessary, apply them lightly several times to let friction dry out the pads.
- Always be sure there are no obstacles or people behind your vehicle when operating in reverse. When it's safe to proceed in reverse, move slowly. Avoid turning at sharp angles in reverse.
- Always use the proper size and type of tires specified in this manual. Always maintain proper tire pressure as specified on safety labels.
- Never modify this vehicle through improper installation or use of accessories.
- Never exceed the stated load capacity for this vehicle. Cargo should be properly distributed and securely attached. Reduce speed and follow the instructions in this manual for hauling cargo, with attachments installed or pulling a trailer. Allow a greater distance for braking. Keep the attachment arm low (if equipped) and slow down when turning.
- Check that the attachment is securely fastened to the machine.
- Check for underground lines before operating attachment (if applicable).
- Disengage PTO (if equipped), put the gear selector lever in PARK, stop the engine and make sure all rotating components are stopped before exiting utility vehicle.
- Always stop the engine before refueling. Remove flammable material containers from the box before filling them with fuel. Make sure the refueling area is well ventilated and free of any source of flame or sparks. Fuel is extremely flammable. See your BRUTUS owner's manual for fuel safety warnings.
- Always remove the ignition key when the vehicle is not in use to prevent unauthorized use or accidental starting.

FOR MORE INFORMATION ABOUT SAFETY, call POLARIS at 1-800-342-3764.

Operator Safety

Equipment Modifications

We strongly recommend that consumers do not install on a POLARIS BRUTUS any equipment that may increase the speed or power of the vehicle, or make any other modifications to the vehicle for these purposes. Any modifications to the original equipment of the vehicle create a substantial safety hazard and increase the risk of bodily injury.

The warranty on your POLARIS BRUTUS is terminated if any equipment has been added to the vehicle, or if any modifications have been made to the vehicle, that increase its speed or power.

The addition of certain accessories, including (but not limited to) mowers, blades, tires, sprayers, or large racks, may change the handling characteristics of the vehicle. Use only POLARIS-approved accessories and attachments, and familiarize yourself with their function and effect on the vehicle.

WARNING!

Failure to operate the BRUTUS properly can result in a collision, loss of control, accident or overturn, which may result in serious injury or death. Heed all safety warnings outlined in this section of the owner's manual. See the OPERATION section of the owner's manual for proper operating procedures.

Age Restrictions

This vehicle is an ADULT VEHICLE ONLY. NEVER operate this vehicle if you are under age 16 and NEVER operate without a valid driver's license.

No person under the age of 12 may ride as a passenger in this vehicle. Any passenger must be able to comfortably reach the floor and hand holds.



Operating Without Instruction

Operating this vehicle without proper instruction increases the risk of an accident. The operator must understand how to operate the vehicle properly in different situations and on different types of terrain.

All operators must read and understand the Owner's Manual and all warning and instruction labels before operating the vehicle and attachment.

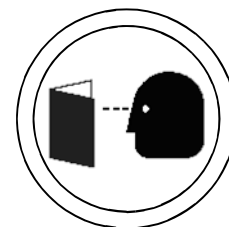

Using Alcohol or Drugs

Operating the vehicle after consuming alcohol or drugs could adversely affect operator judgment, reaction time, balance and perception.

Never drink alcohol or use drugs or medications before or while operating this vehicle.



Seat Belts

Riding in this vehicle without wearing the seat belt increases the risk of serious injury in the event of an accident or sudden stop. Riders *must* wear seat belts at all times. Seat belts reduce the severity of injury in the event of a sudden stop or accident. Always make sure the seat belts are secured for both the operator and passengers before riding.

Protective Eyewear

Riding in this vehicle without wearing protective eye wear increases the risk of a serious injuries in the event of an accident. Operator and all passengers *must* always wear approved eye protection (goggles).

Operating With a Load on the Vehicle

The weight of both cargo, passengers and attachments impacts vehicle operation. For your safety and the safety of others, carefully consider how your vehicle is loaded and how to safely operate the vehicle. Follow the instructions in this manual for loading, tire pressure, gear selection and speed.

- **Do not exceed vehicle weight capacities.** The vehicle's maximum weight capacity is listed in the specifications section of the owner's manual and on a label on the vehicle. When more passenger weight is added, cargo weight may need to be reduced accordingly.
- The recommended tire pressures are listed in the specifications section of the BRUTUS owner's manual.

Always follow these guidelines:

Under ANY of these conditions:	Do ALL of these steps:
Passenger and/or cargo exceeds half the maximum weight capacity	1. Slow down. 2. Verify tire pressure. 3. Use extra caution when operating.
Operating in rough terrain	
Operating over obstacles	
Climbing an incline	
Towing	
Operating with attachments installed	

SAFETY

Failure to Inspect Before Operating

Failure to inspect and verify that the vehicle is in safe operating condition before operating increases the risk of an accident.

Always inspect your BRUTUS and attachment before each use to make sure it's in safe operating condition.

Always follow all inspection and maintenance procedures and schedules described in the owner's manual.

Exposure to Exhaust

Engine exhaust fumes are poisonous and can cause loss of consciousness or death in a short time. Never start the engine or let it run in an enclosed area.

The engine exhaust from this product contains chemicals known to cause cancer, birth defects or other reproductive harm. Operate this vehicle only outdoors or in well-ventilated areas.

Operating a Damaged Vehicle

Operating a damaged vehicle or attachment can result in an accident. After any overturn or accident, have a qualified service dealer inspect the entire machine for possible damage, including (but not limited to) brakes, throttle and steering systems.

Operating at Excessive Speeds

Operating this vehicle at excessive speeds increases the operator's risk of losing control. Always operate at a speed that's appropriate for the terrain, the visibility and operating conditions, your skills and your passengers' skills.

Turning Improperly

Turning improperly could cause loss of traction, loss of control, accident or overturn. Always follow proper procedures for turning. Never turn abruptly or at sharp angles. Never turn at high speeds. Practice turning at slow speeds before attempting to turn at faster speeds.

Operating on Public Roads

Operating this vehicle on public streets, roads or highways could result in a collision with another vehicle.

Never operate this vehicle on any public street, road or highway, including dirt and gravel roads. In some areas it's unlawful to operate this vehicle on public streets, roads and highways.

Jumps and Stunts

Attempting wheelies, jumps and other stunts increases the risk of an accident or overturn. Never attempt wheelies, jumps, or other stunts. Avoid exhibition driving.

Operating in Unfamiliar Terrain

Failure to use extra caution when operating on unfamiliar terrain could result in an accident or overturn. Unfamiliar terrain may contain hidden rocks, bumps, or holes that could cause loss of control or overturn.

Travel slowly and use extra caution when operating on unfamiliar terrain. Always be alert to changing terrain conditions.

Operating on Slippery Terrain

Failure to use extra caution when operating on excessively rough, slippery or loose terrain could cause loss of traction, loss of control, accident or overturn.

Do not operate on excessively slippery surfaces.

Always reduce speed and use additional caution when operating on slippery surfaces.

Improper Hill Climbing

Climbing hills improperly can cause loss of control or vehicle overturn. Always follow proper procedures for climbing hills as described in the BRUTUS owner's manual.

Stalling While Climbing a Hill

Stalling or rolling backwards while climbing a hill could cause an overturn. Always maintain a steady speed when climbing a hill.

If all forward speed is lost:

- Apply the brakes.
- Place the transmission in reverse and slowly allow the vehicle to roll straight downhill while applying light brake pressure to control speed.

If you begin rolling downhill:

- Never apply engine power.
- Apply the brakes gradually until the vehicle is fully stopped.
- Place the transmission in reverse and slowly allow the vehicle to roll straight downhill while applying light brake pressure to control speed.

Improper Tire Maintenance

Operating this vehicle with improper tires or with improper or uneven tire pressure could cause loss of control or accident.

Always use the size and type of tires specified for your vehicle.

Always maintain proper tire pressure as described in the owner's manual and on safety labels.

Operating on Frozen Bodies of Water

Severe injury or death can result if the vehicle and/or the operator fall through the ice. Never operate the vehicle on a frozen body of water unless you have first verified that the ice is sufficiently thick to support the weight and moving force of the vehicle, you and your passengers, and your cargo, together with any other vehicles in your party. Always check with local authorities and residents to confirm ice conditions and thickness over your entire route. Vehicle operators assume all risk associated with ice conditions on frozen bodies of water.

Unauthorized Use of the Vehicle

Leaving the keys in the ignition can lead to unauthorized use of the vehicle, which could result in an accident or overturn. Always remove the ignition key when the vehicle is not in use.

Hot Exhaust Systems

Exhaust system components are very hot during and after use of the vehicle. Hot components can cause burns and fire. Do not touch hot exhaust system components. Always keep combustible materials away from the exhaust system. Use caution when traveling through tall grass, especially dry grass.

Component Locations

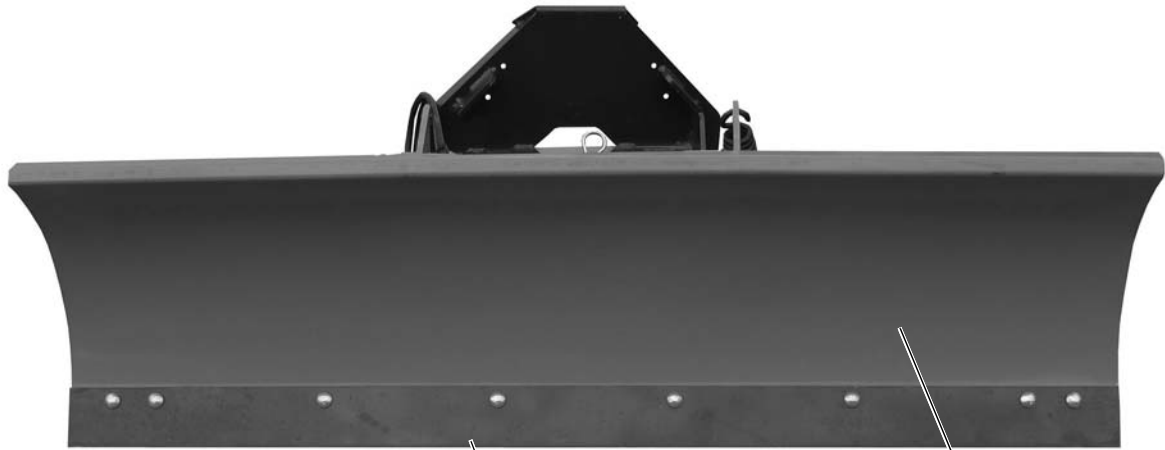

Cutting Edge

Moldboard

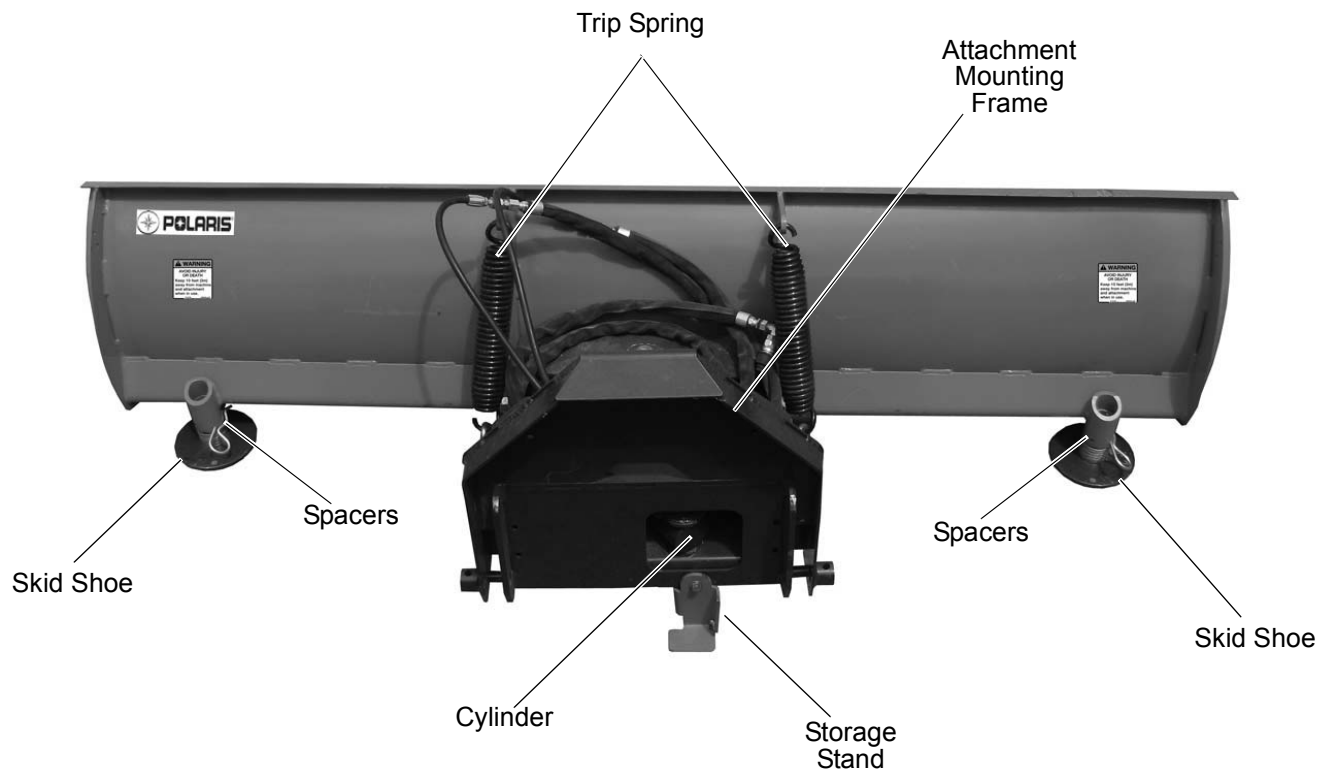

Trip Spring

Attachment
Mounting
Frame

Spacers

Skid Shoe

Spacers

Skid Shoe

Cylinder

Storage
Stand

FEATURES AND ACCESSORIES

Standard Items

The front mount snow blade is equipped with the following Standard items:

- Moldboard That Angles Right Or Left Up To 30°
- Trip Moldboard
- Bolt On Replaceable Cutting Edges
- Cylinder Shear Bolt
- Storage Stand

Required Kits For Attachment

Auxiliary Relief Kit

Options And Accessories

Below is a list of Options and Accessories available for the angle broom. See your dealer for other available options and accessories:

- Rubber Or Polyether Cutting Edges Available
- Side Marker Kit
- Rubber Snow Deflector

Adjusting Skid Shoe Height

Raise the snow blade off the ground. Place blocks (Item 1) under the cutting edge (both sides) to hold the skid shoes off the ground.

Lower the snow blade until it rest securely on the blocks (Item 1).

Stop the engine and exit the vehicle. See page 16.

Remove the retaining pin (Item 2) and the skid shoe (Item 3).

Install or remove spacers (Item 4) as needed to position the skid shoe to the desired height.

Insert the skid shoe (Item 3) all the way into the skid shoe sleeve (Item 5).

Tip: If the skid shoes are not installed properly, the weight of the snow blade will be put on the retaining pins instead of the washers and may cause damage.

Reinstall the retaining pin through a retaining pin hole in the skid shoe sleeve (Item 5).

Tip: There are two retaining pin holes in the skid shoe sleeve. Depending on the amount of spacers used, one hole will be open and one hole will be blocked. If the pin will not go through one hole, use the other hole.

Repeat the procedure on the opposite side, make sure both skid shoes are adjusted to the same height.

Store unused skid shoe spacers (Item 6) on the storage peg (Item 7) located near the front mounting plate. Install the retaining pin (Item 8).

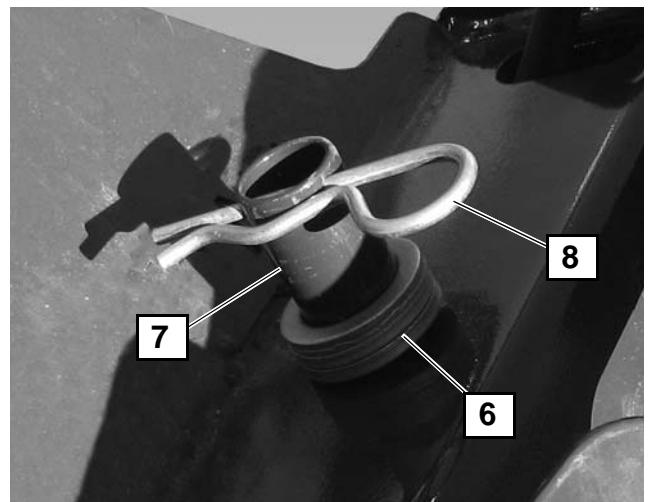
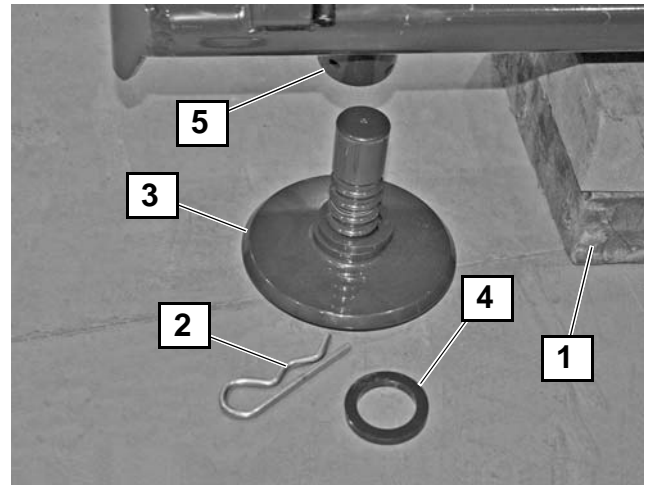

Snow Blade Mounting Frame

Inspect the mounting flange (Item 1), pin mounts (Item 2), storage stands (Item 3) and all welds on the attachment for wear or damage each time the attachment is removed from the machine.

Check the following items at the start of the work day:

- Check for damaged or missing decals. Replace if necessary.
- Replace any worn or damaged parts immediately.

DAILY INSPECTION

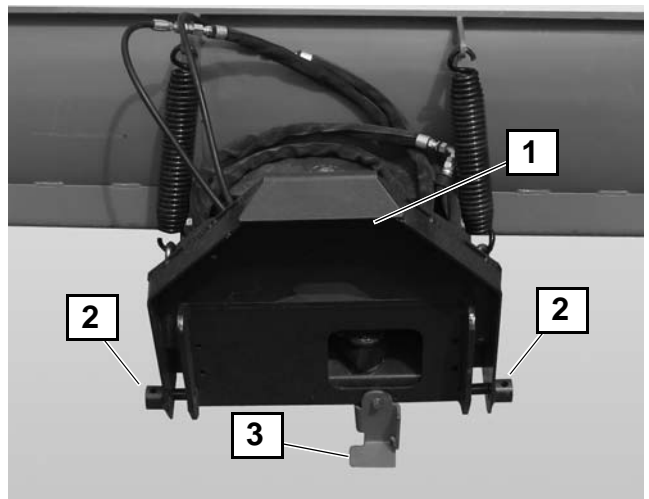

DAILY INSPECTION PRO-TACH Attachment Mounting Frame

WARNING!

MACHINE ROLLAWAY CAN CAUSE SERIOUS INJURY OR DEATH
Place the gear selector lever in PARK before leaving the operator's seat.

Inspect the mounting frame (Item 1) and all welds on the attachment mount for wear and damage each time the attachment is removed from the machine.

Check the attachment mounting pins (Item 2) for wear or damage. ensure mounting pins are securely fastened in there storage location.

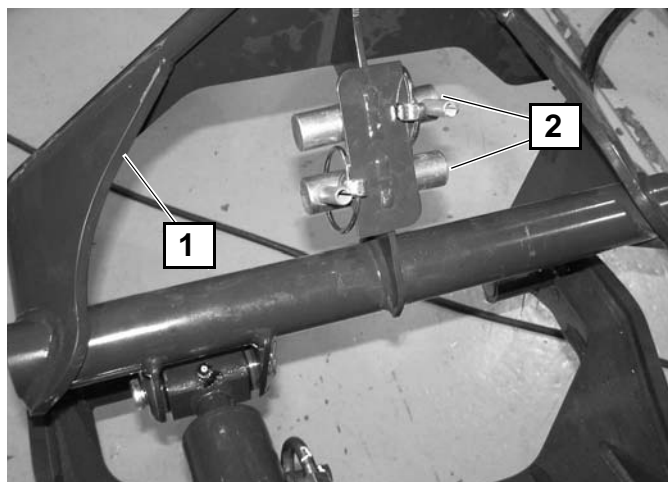
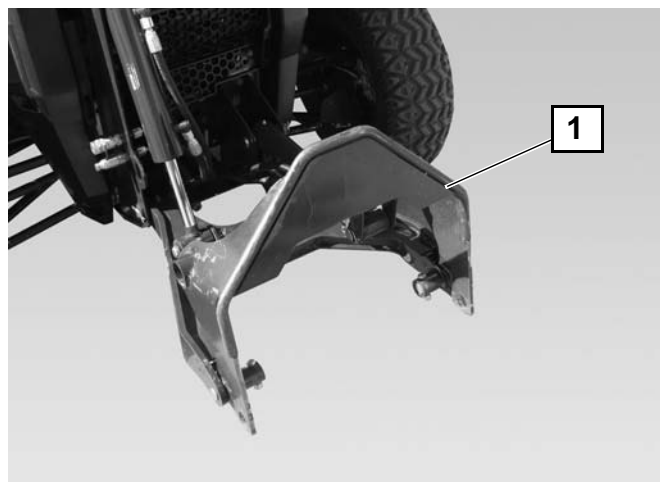

Approved Utility Vehicle Models And Requirements

UTILITY VEHICLE	SB69
BRUTUS HD and HDPTO	X

The above chart lists the snow blade approved for use on the BRUTUS HDPTO.

The warranty is void if this attachment is used on a non-approved carrier. See your Polaris dealer for an updated list of approved carriers.

WARNING!

Never use attachments or buckets which are not approved by Polaris. Attachments and buckets for safe loads of specified densities are approved for each model. Unapproved attachments and buckets can cause injury or death.

The utility vehicle must be equipped with front auxiliary hydraulics (Item 1) for proper operation of the chute rotation. See your dealer for available kits for your model utility vehicle.

The utility vehicle must be equipped with the auxiliary relief kit for proper operation of the snow blade. See your dealer for the auxiliary relief kit.

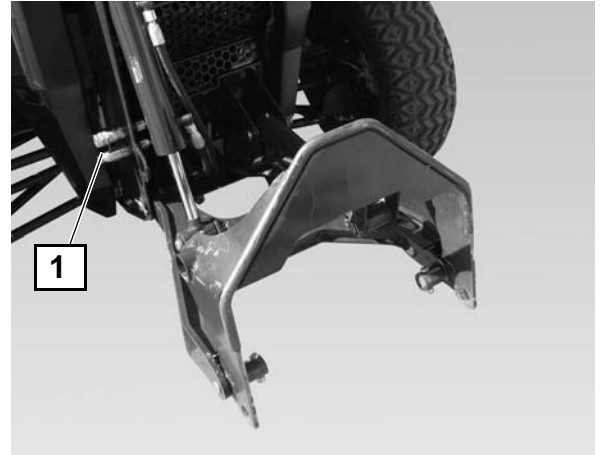

OPERATION

Entering and Existing The Utility Vehicle

Entering

WARNING!

Operator must have instructions before operating the machine. Untrained operators can cause injury or death.

WARNING!

AVOID INJURY OR DEATH

When operating the machine:

- Operate only from the driver's seat.
- Keep the seat belts fastened snugly.
- Keep entire body inside the vehicle.

Enter and exit the operator seat of the utility vehicle from the left side.

Tip: The left side of the utility vehicle as viewed from the operator seat.

Insert the tab (Item 1) into the buckle (Item 2). Position the lap belt as low as possible on the hips – not on the waist, then adjust it to a snug fit by pulling the shoulder portion upward through the latch plate.

Tip: Use a single safety belt for one person at a time. Do not use a single safety belt for two or more people - this includes children.

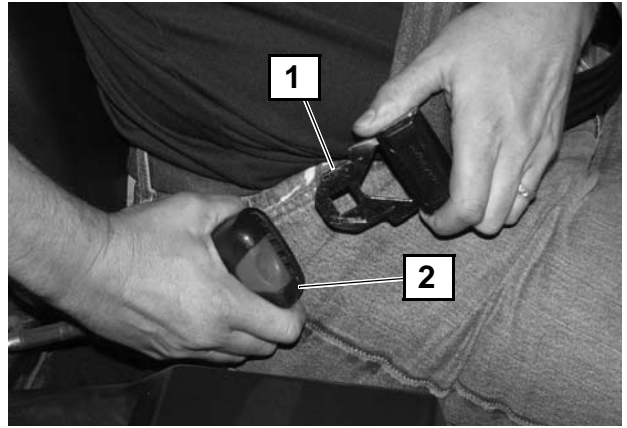

Exiting

WARNING!

AVOID INJURY OR DEATH

Before leaving the operator seat:

- Park on flat level ground.
- Lower the attachment arm, put the attachment flat on the ground.
- Press the brake and put the gear selector lever in PARK.
- Stop the engine and remove the key.

SEE THE BRUTUS OWNER'S MANUAL FOR MORE INFORMATION.

To release the seat belt, press the buckle release button (Item 1) and allow the belt to retract.

Remove the key to prevent operation of the utility vehicle by unauthorized personnel.

Exit the utility vehicle.



Installation

Installing The Snow Blade

Always inspect the utility vehicle's mounting frame and attachment front mounting frame before installation. See the BRUTUS owner's manual. See Daily Inspection on page 14.

WARNING!

Warnings on the machine and in the manuals are for your safety. Failure to obey warnings can cause serious injury or death.

WARNING!

Keep fingers and hands out of pinch points when installing and removing attachments.

1. Enter the utility vehicle. See page 16.
 2. Start the engine.
 3. Move the gear selector lever to Low.
 4. Tilt the mounting frame (Item 1) of the utility vehicle forward. Slowly drive forward until the front edge of the attachment interface (Item 1) is completely under the top lip of the attachment mounting frame (Item 2).
 5. Raise the utility vehicle's attachment arm until the mounting frame engages the attachment mounting frame and starts to raise the attachment off the ground.
 6. Tilt the attachment interface backward until the attachment is slightly off the ground.
 7. Move the gear selector lever to Park. Stop the engine and exit the utility vehicle. See page 16.
 8. Rotate the storage stand (Item 3) up.
9. Remove the two retainer pins (Item 4) and pins (Item 5) from the storage location on the mounting frame.

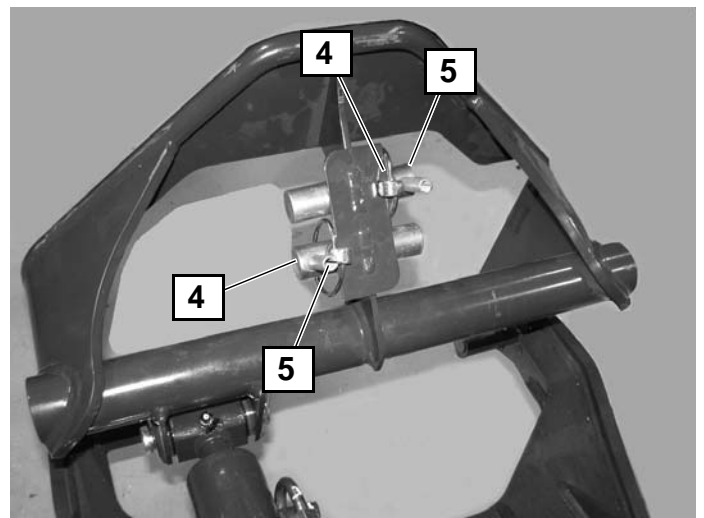
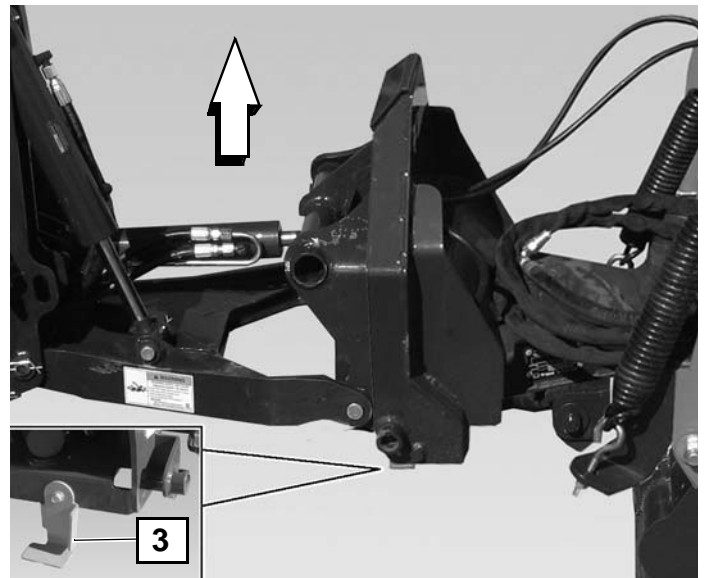
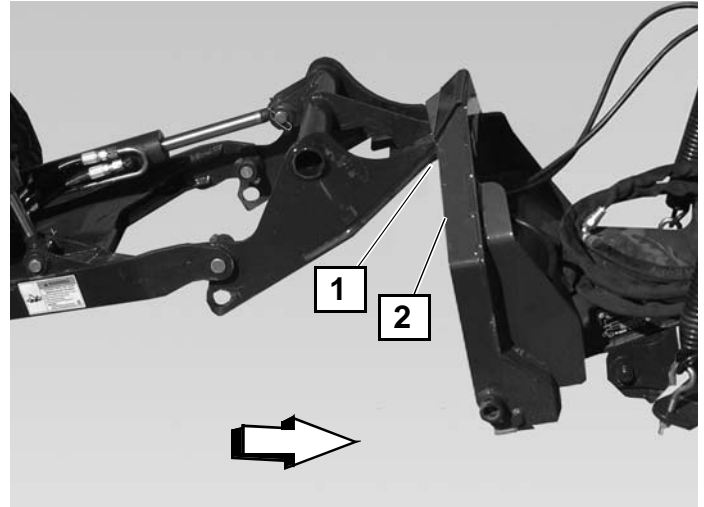

OPERATION

Installation

Installing The Snow Blade

10. Install the pin (Item 6) and retainer pin (Item 7) (both sides).
11. Connect the hoses to the hydraulic quick couplers. (See page 19).

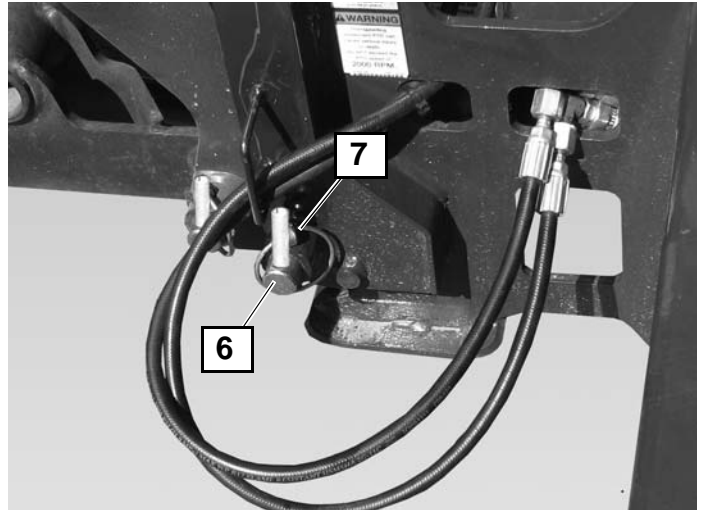

Leveling The Snow Blade

The snow blade should be leveled before every use. This will position the snow blade parallel to the ground.

1. The tilt cylinder (Item 1) is used to adjust the front to back level of the attachment.
2. Using the tilt function of the utility vehicle, level the snow blade.
3. Once the attachment is leveled - engage the tilt lock. See page 20.

Tip: The snow blade is level (parallel to the ground) when rotating the blade to the left and right and the blade tips remain level to the ground. See Page 20.

Tip: Once the attachment is leveled, the tilt function of the utility vehicle can be locked so it does not need to be readjusted. (See the BRUTUS Owner's Manual for additional information).

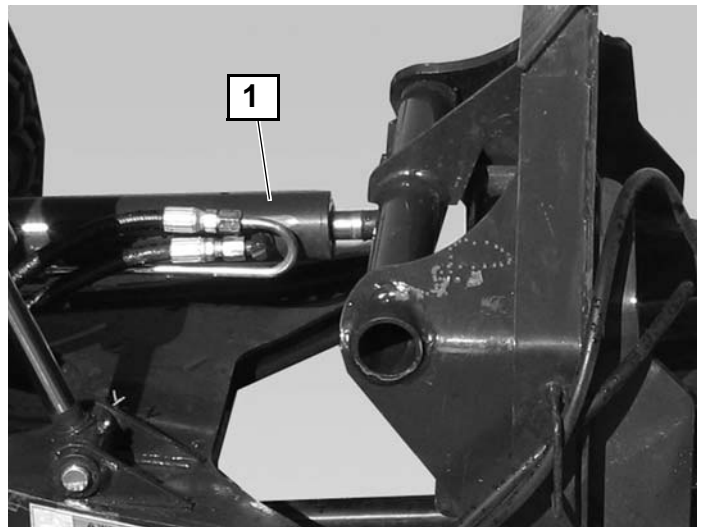

Hydraulic Quick Couplers

New attachments and new BRUTUS HD and HDPTO models are factory equipped with flush face couplers. If installing an attachment equipped with other couplers, the attachment couplers will have to be changed to match the BRUTUS. See your dealer for parts.

Tip: Make sure the quick couplers are fully engaged. If the quick couplers do not fully engage, check to see that the couplers are the same size and type.

WARNING!

AVOID BURNS

Hydraulic fluid, tubes, fittings and quick couplers can get hot when running machine and attachments. Be careful when connecting and disconnecting quick couplers.

To Connect:

Remove dirt or debris from the both the female and male couplers. Visually check the couplers for corrosion, damage or excessive wear, if any of these conditions exist, the couplers must be replaced. Align the notched out area of the sleeve (Item 1) with the ball on the base (Item 2) and retract the sleeve on the female coupler. Insert the male coupler and push the couplers tightly together. Pull back firmly on the male coupler to make sure the couplers have engaged properly.

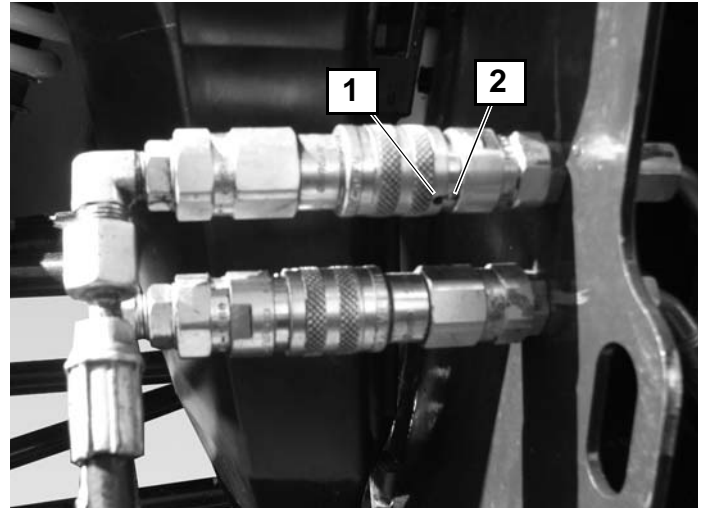

To Disconnect:

Align the notched out area of the sleeve (Item 1) with the ball on the base (Item 2). Push the couplers together, retract the sleeve on the female coupler until the couplers disconnect. Pull to disengage the male coupler.

For First Time Installation

With the utility vehicle's engine off, connect the attachment couplers to the utility vehicle couplers. Check the attachment hoses so they are not twisted and they route to the utility vehicle without contacting any moving parts. It may be necessary to loosen the couplers on the hoses to remove any twists in the hoses. Tighten all connections before starting the utility vehicle.

Tip: Check the attachment hydraulic hoses so the hoses are not twisted or contacting any moving parts of the BRUTUS or attachment.

OPERATION

Controls

Joystick

The joystick control lever will be used to control the utility vehicle PRO-TACH attachment system.

Move the joystick control lever forward to lower the attachment arm (Item 1).

Move the joystick control lever backward to raise the attachment arm (Item 2).

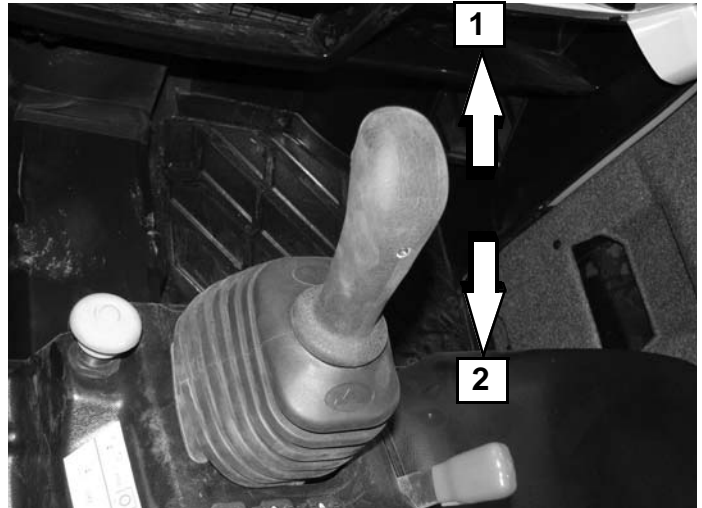

Float

Move the joystick control lever all the way forward until it locks in the detent (float) position to have the utility vehicle PRO-TACH in the float position.

Move the joystick back to disengage float.



Rotating The Snow Blade

Press the switch to the left (Item 1) to rotate the snow blade counterclockwise.

Press the switch to the right (Item 2) to rotate snow blade clockwise.

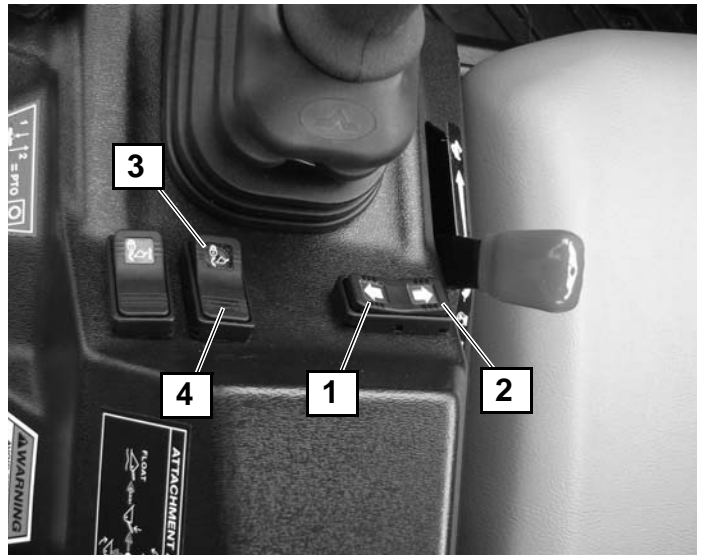

Tilt Lock Switch

Press the tilt lockout switch forward (Item 3) to engage the tilt lock.

Press the tilt lockout switch backward (Item 4) to disengage the tilt lock.

Driving The Utility Vehicle and The Snow Blade To The Worksite

Read and understand the attachment Owner's Manual and the BRUTUS Owner's Manual prior to installing or using any attachment.

WARNING!

VEHICLE TIPPING OR ROLLOVER CAN CAUSE SERIOUS INJURY OR DEATH

- Keep the attachment arm as low as possible.
- Turn on level ground. Slow down when turning.
- Go up and down slopes, not across them.
- Keep the heavy end of the vehicle uphill.
- Do not exceed vehicle load capacity.
- Check for adequate traction.

WARNING!

When operating the machine:

- Operate only from the driver's seat.
- Keep the seat belts fastened snugly.
- Keep entire body inside the vehicle.

Enter the utility vehicle. See page 16.

Start the engine.

Raise the snow blade to the travel position. See Controls on page 20.

Tip: Keep the snow blade as low as possible for travel.

Drive the utility vehicle and attachment to the work area.



OPERATION

Operating The Snow Blade

The snow blade is used to clear snow from sidewalks, drive-ways and parking lots.

Trip Springs

The snow blade is equipped with trip springs (Item 1) which will allow the snow blade to tilt forward when the cutting edge hits an obstruction.

Reset the trip spring after hitting an obstruction, raise the snow blade, or slowly back up the utility vehicle.

WARNING!

AVOID SERIOUS INJURY OR DEATH

Hitting obstructions with the snow blade angled and the front tires off the ground can cause loss of traction. Ensure the front tires are in contact with the ground at all times.

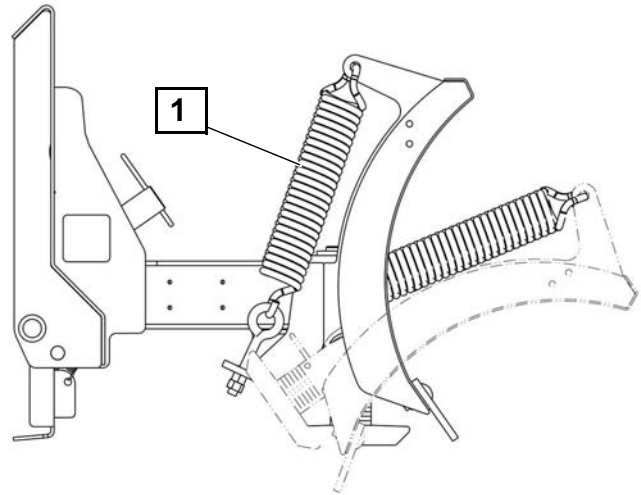
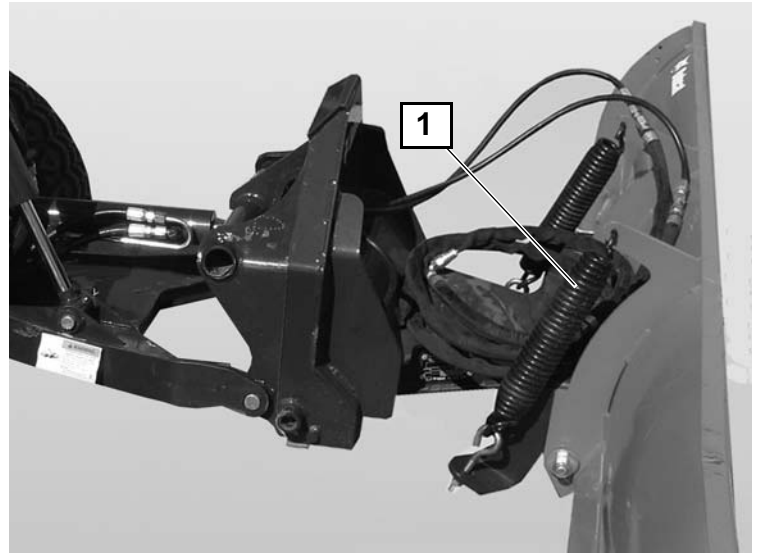

Pushing Snow

Change the angle of the snow blade to the desired position. See page 16.

With the operator in the operator's position and seat belt fastened, start the engine. See BRUTUS owner's manual for detailed information.

The snow blade can be used in either the float position or lowered to the desired position with the joystick. See page 20.

Move the utility vehicle forward to push snow.



Operating The Snow Blade Back Dragging Snow

Small amounts of snow (example: snow that remains next to a garage door) can be back dragged when operating the utility vehicle with the snow blade in the float position. (See page 20.

Back dragging large amounts of snow with the snow blade is not recommended. The trip springs (Item 1) protect the front mount snow blade from damage only when going forward.

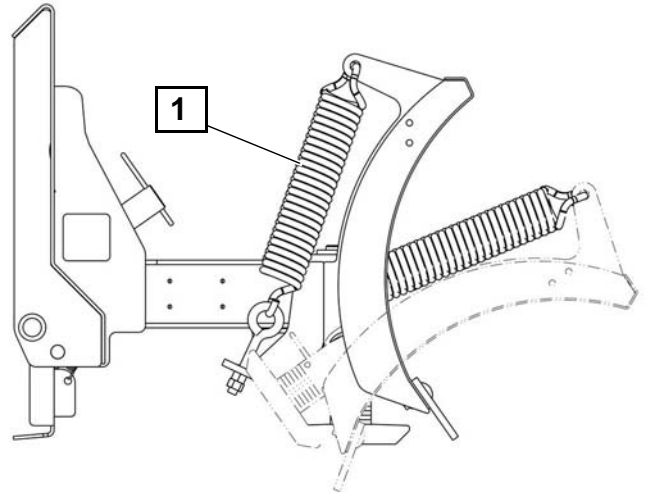
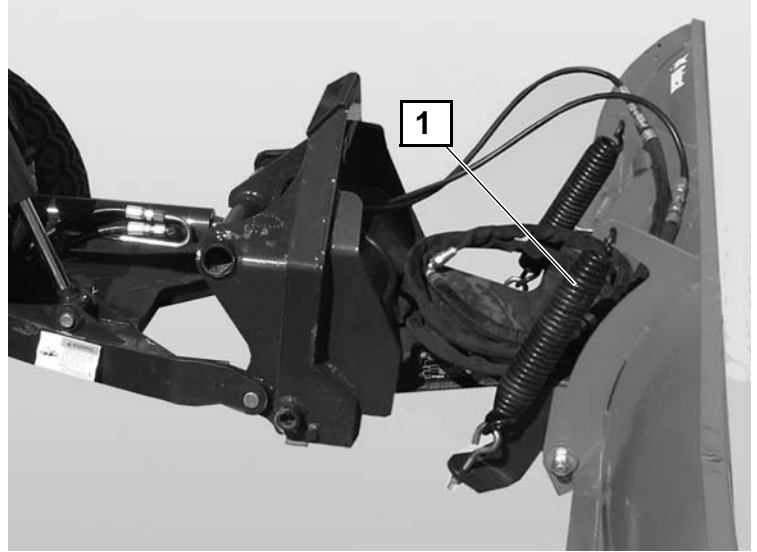

OPERATION

Removal

Removing The Snow Blade

Tip: In muddy conditions or to prevent the attachment from freezing to the ground, put the attachment on planks or blocks before removing the attachment from the machine.

WARNING!

AVOID INJURY OR DEATH

Before leaving the operator seat:

- Park on flat level ground.
- Lower the attachment arm, put the attachment flat on the ground.
- Press the brake and put the gear selector lever in PARK.
- Stop the engine and remove the key.

SEE THE BRUTUS OWNER'S MANUAL FOR MORE INFORMATION.

1. Always park on flat level ground. Fully lower the attachment arm and put the attachment flat on the ground.
2. Stop the engine.
3. Release auxiliary hydraulic pressure. See the BRUTUS owner's manual for the correct procedure.
4. Exit the utility vehicle. See page 16.
5. Disconnect the auxiliary hydraulic couplers. See page 19.
6. Remove the retaining pins (Item 1) (both sides).
7. Remove the pins (Item 2) (both sides).
8. Install the two pins (Item 3) and retaining pins (Item 4) in the storage location on the mounting frame.

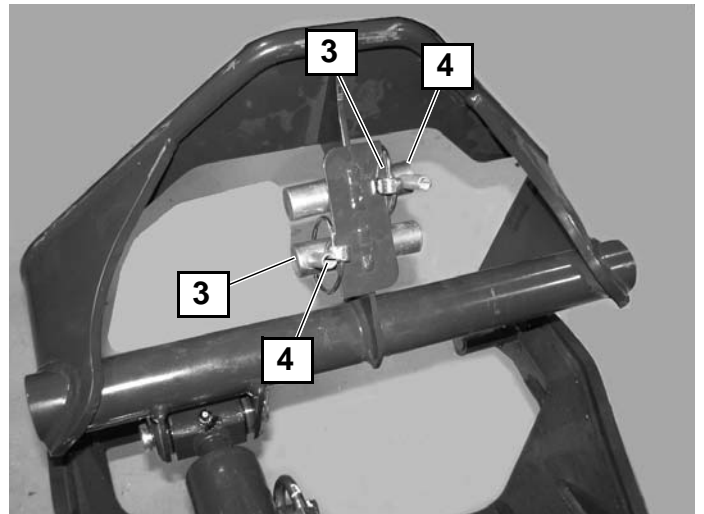
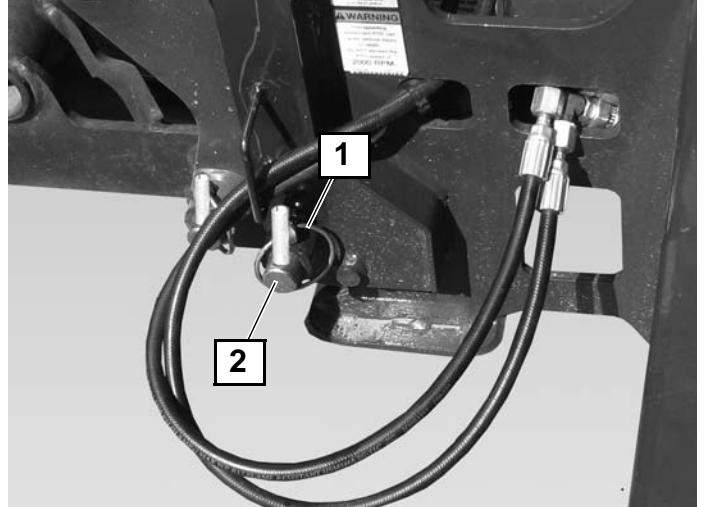

Removal

Removing The Snow Blade

9. Rotate the storage stand (Item 5) to the down position.
10. Slowly lower the attachment arm and tilt it forward until the attachment is released from the mounting frame. See page 20.

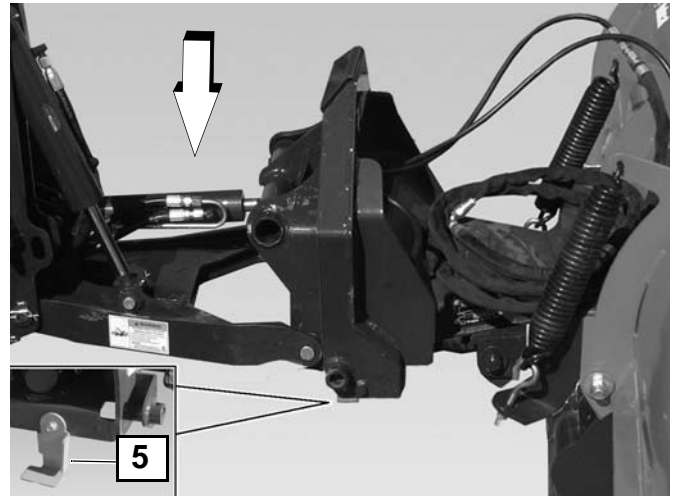

11. Slowly drive the Brutus backwards away from the attachment.

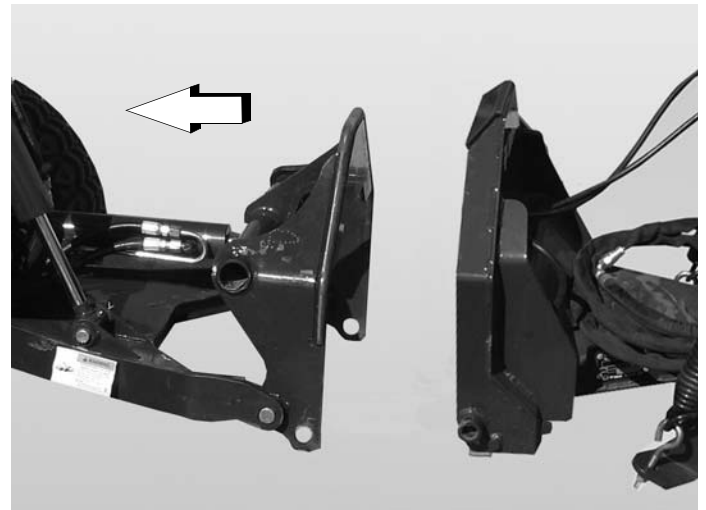

LIFTING THE ATTACHMENT Procedure

Fasten the chain to the snow blade (Item 1).

Tip: Use chains that are in good condition and of adequate size to lift the attachment.

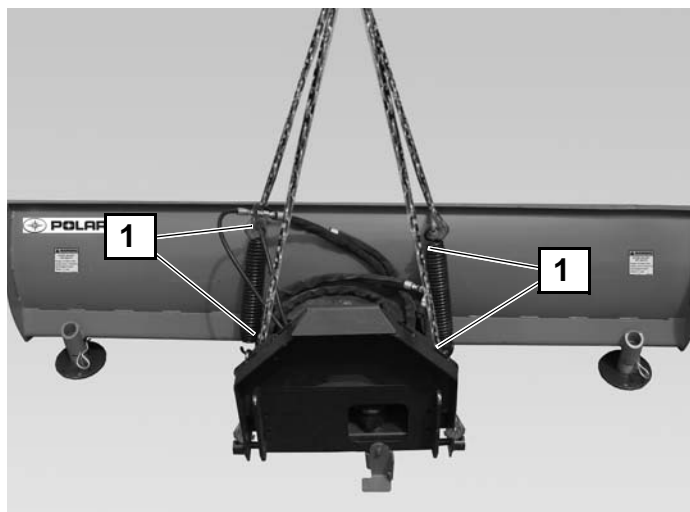

TRANSPORTING THE ATTACHMENT ON A TRAILER Fastening

With the snow blade on the transport vehicle, route the chains (Item 1) through the front mount.

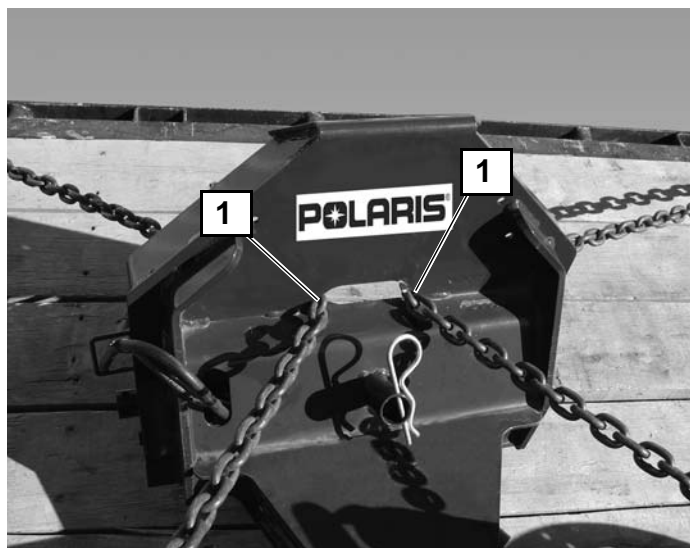

Route the chains over the top of the moldboard and to the trailer tie downs (Item 2).

Use chain binders (Item 3) to prevent the snow blade from moving during transport.

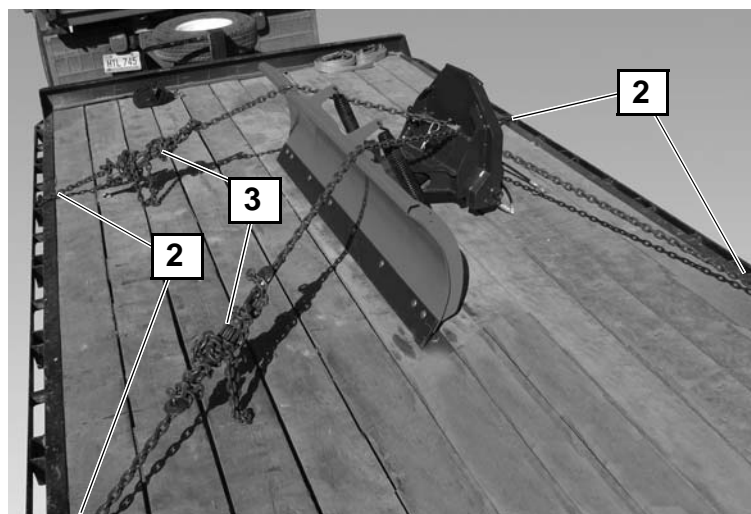

TRANSPORTING THE ATTACHMENT ON A TRAILER

Loading and Fastening

WARNING!

AVOID INJURY OR DEATH

Adequately designed ramps of sufficient strength are needed to support the weight of the machine when loading onto a transport vehicle. Wood ramps can break and cause personal injury.

Be sure the transport and towing vehicles are of adequate size and capacity for weight of machine and attachment combination. (See utility vehicle and attachment Owner's Manuals for specifications.)

Loading

The rear of the trailer must be blocked or supported when loading and unloading to prevent the front of the trailer from raising.

- Load the heaviest end of the machine and attachment combination first.
- Lower the attachment to the floor.
- Stop the engine.
- Exit the utility vehicle. See page 16.

Fastening

Install the chains at the front and rear tie down positions on the BRUTUS. See BRUTUS owner's manual for procedure.

- Install chains on the attachment (if needed).
- Fasten each end of the chain to the transport vehicle and secure with chain binders.

Tip: Use chain binders to prevent the attachment and machine from moving during transport.



MAINTENANCE SAFETY

WARNING!

Instructions are necessary before operating or servicing machine. Read and understand the Owner's Manual, Operator's Handbook and signs (decals) on machine. Follow warnings and instructions in the manuals when making repairs, adjustments or service. Check for correct function after adjustments, repairs or service. Untrained operators and failure to follow instructions can cause injury or death.

CORRECT



WARNING!

Never service attachments without instructions. See Owner's Manual and Attachment Service Manual.

WARNING!

Cleaning and maintenance are required daily.

WARNING!

Never service or adjust attachment with the engine running unless instructed to do so in manual.

WARNING!

Always lower the attachment to the ground before lubricating or servicing.

WARNING!

Avoid contact with leaking hydraulic fluid or diesel fuel under pressure. It can penetrate skin or eyes.

WARNING!

Stop, cool and clean engine of flammable materials before checking fluids.

WARNING!

Keep body, loose objects and clothing away from moving parts, electrical contacts, hot parts and exhaust.

WARNING!

Safety glasses are needed for eye protection from electrical arcs, battery acid, compressed springs, fluids under pressure and flying debris or when tools are used. Use eye protection approved for type of welding.

WARNING!

Instructions are necessary before operating or servicing machine. Read and understand the Owner's Manual, Operator's Handbook and signs (decals) on machine. Follow warnings and instructions in the manuals when making repairs, adjustments or service. Check for correct function after adjustments, repairs or service. Untrained operators and failure to follow instructions can cause injury or death.

Chart

PROBLEM	CAUSE	CORRECTION
Snow blade does not mount properly on the front mount frame.	Attachment pin holes have debris in them.	Remove debris from the pin holes.
	Snow, ice or other debris lodged between the front mount frame and the snow blade.	Remove debris from between front mount frame and snow blade.
	Worn or damaged parts.	Replace worn or damaged parts.
Cannot change angle of snow blade.	No hydraulic flow.	Check quick coupler connections. Check for damaged hose ends and fittings.
	Cylinder shear bolt broken.	Replace shear bolt.
Snow blade is hard to control.	Skid shoes worn.	Replace skid shoes.
	Worn pins.	Replace pins.
	Too much down pressure on the blade.	Lift to the proper height.
Uneven cutting edge wear.	Turn buckle not properly adjusted.	Adjust as required.

MAINTENANCE

Trip Spring Removal And Installation

WARNING!

Be careful when removing or installing parts which have spring tension. Wear safety glasses or goggles. Failure to obey warnings can cause injury or death.

Removal

1. Remove the two nuts (Item 1).
2. Push forward on the top of the moldboard (Item 2) rotating it forward. Rotate mold board forward lift up on the spring (Item 3) until the tension bolt (Item 4) can be removed from the mounting bracket (Item 5).
3. Rotate the spring (Item 6) and remove from the moldboard (Item 7).

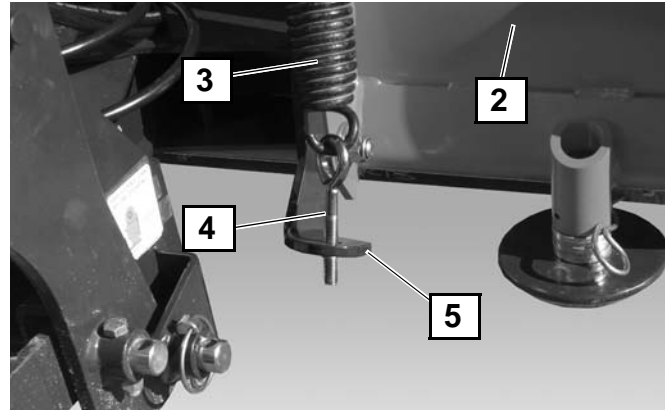
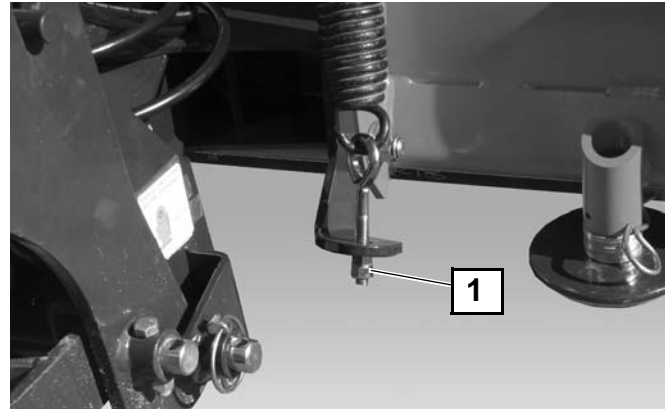

4. Rotate the spring (Item 8) and remove from the tension bolt (Item 9).

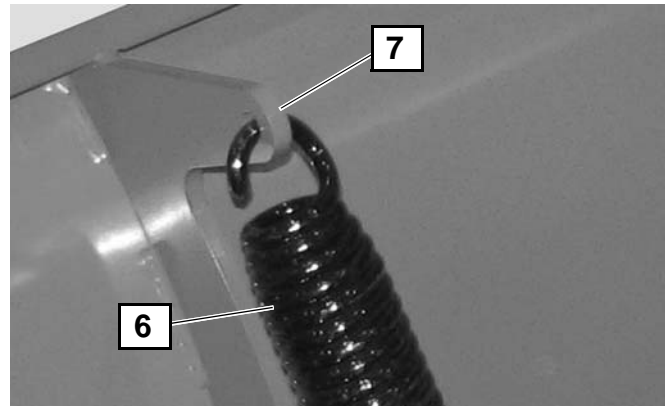

Installation

1. Install the spring (Item 8) into the tension bolt (Item 9).
2. Rotate the spring (Item 6) and install in the moldboard (Item 7).
3. Press the top of the moldboard (Item 2) and install the tension bolt (Item 4) into the mounting bracket (Item 5).
4. Install the two nuts (Item 1).

Tip: If the blade trips too easily, loosen the lower nut slightly, then tighten the upper nut until the desired tension is acquired. Tighten the lower nut to the upper nut to lock the nuts in place.

Tip: If the blade trips too hard, loosen the lower nut slightly, then tighten the upper nut until the desired tension is acquired. Tighten the lower nut to the upper nut to lock the nuts in place.

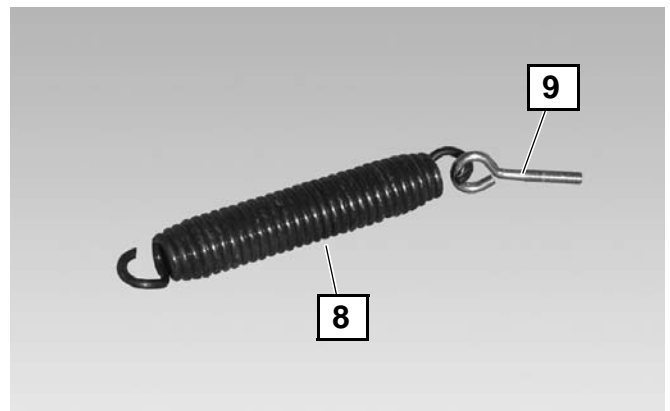

Skid Shoe Removal And Installation

WARNING!

AVOID INJURY OR DEATH

Wear safety glasses to prevent eye injury when any of the following conditions exist:

- When fluids are under pressure.
- Flying debris or loose material is present.
- Engine is running.
- Tools are being used.

Removal

1. Lower the snow blade until it rest securely on the blocks (Item 1).
2. Stop the engine and exit the vehicle. See page 16.
3. Remove the retaining pin (Item 2) and the skid shoe (Item 3).
4. Remove any spacers (Item 4).
5. Store unused washers (Item 6) on the peg near the front mounting plate.

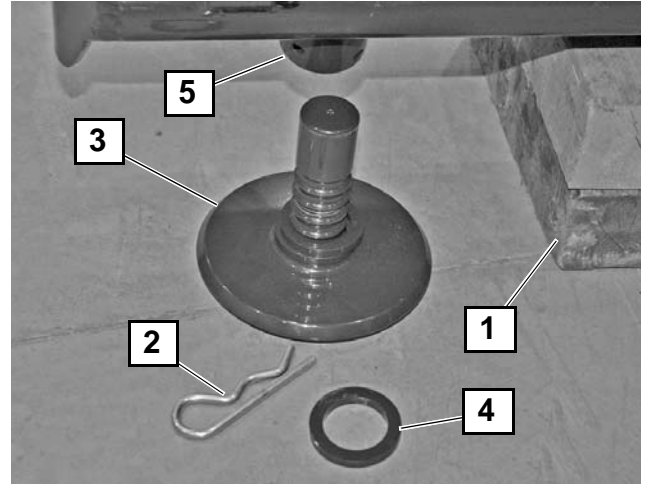

Installation

1. Install the spacers (Item 4) onto the skid shoe (Item 3) to the desired height.
2. Insert the skid shoe (Item 3) all the way into the skid shoe sleeve (Item 5).

Tip: If the skid shoes are not installed properly, the weight of the snow blade will be put on the retaining pins instead of the washers and may cause damage.

3. Reinstall the retaining pin (Item 2) through a retaining pin hole in the skid shoe sleeve (Item 5).

Tip: There are two retaining pin holes in the skid shoe sleeve. Depending on the amount of spacers used, one hole will be open and one hole will be blocked. If the pin will not go through one hole, use the other hole.

4. Repeat the procedure on the opposite side, make sure both skid shoes are adjusted to the same height.
5. Store unused skid shoe spacers (Item 6) on the storage peg located near the front mounting plate.



MAINTENANCE

Cutting Edge Removal And Installation

WARNING!

AVOID INJURY OR DEATH

Securely block up the attachment before working underneath.

1. Raise the snow blade off the ground. Position blocks (Item 1) under the skid shoes. Lower the blade until it rests securely on the blocks.
2. Stop the engine and exit the machine. See page 16.
3. Remove all the bolts (Item 2) and remove the cutting edge (Item 3).

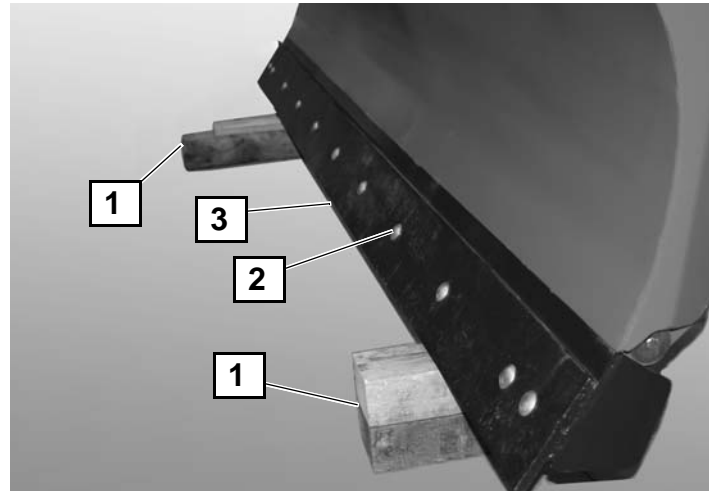

Shear Bolt Removal And Installation

WARNING!

AVOID INJURY OR DEATH

Securely block up the attachment before working underneath.

Removal

1. Raise the snow blade off the ground. Position a jackstand (Item 1) under the blade. Lower the blade until it rests securely on the jackstand.
2. Stop the engine and exit the machine. See page 16.

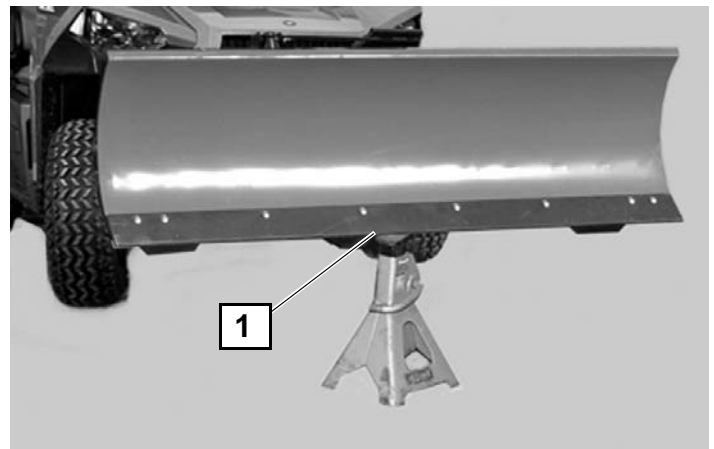

3. Remove the old shear bolt (Item 2) from the base of the angle blade cylinder and remove the bushing (Item 3).

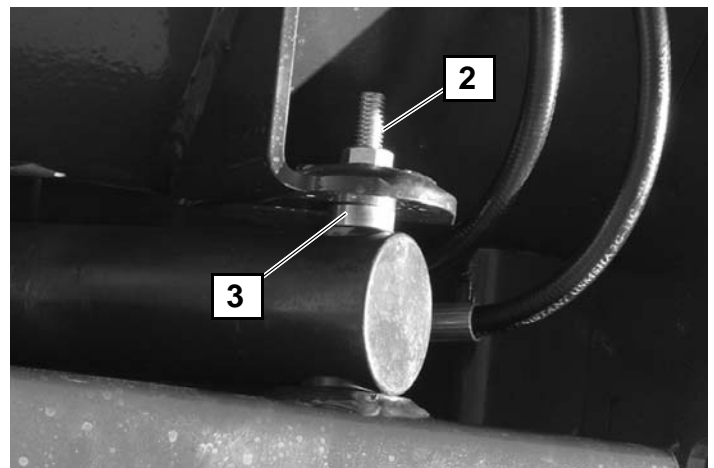

4. Inspect the bushing (Item 4), bolt (Item 5) and nut (Item 6) for damage.

Installation

1. Install the bushing (Item 3).
2. Align the cylinder and install the bolt (Item 2) and nut. Tighten to 20-24 ft.-lbs. (27-32 Nm) torque.

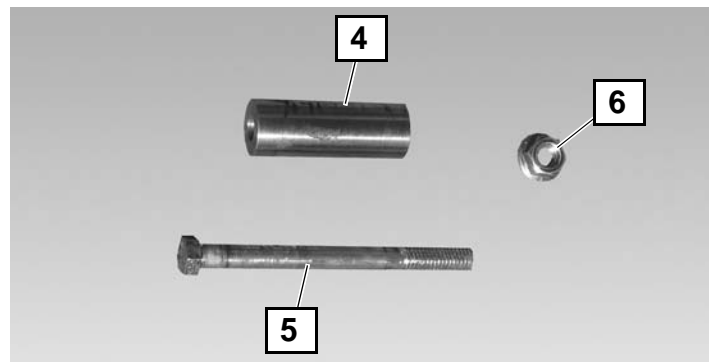

Hydraulic Cylinder Removal And Installation

NOTE: When repairing hydrostatic and hydraulic systems, clean the work area before disassembly and keep all parts clean. Always use caps and plugs on hoses, tubelines and ports to keep dirt out. Dirt can quickly damage the system.

NOTE: Contain and dispose of any oil leakage in an environmentally safe manner.

WARNING!

AVOID INJURY OR DEATH

Wear safety glasses to prevent eye injury when any of the following conditions exist:

- When fluids are under pressure.
- Flying debris or loose material is present.
- Engine is running.
- Tools are being used.

Removal

WARNING!

AVOID INJURY OR DEATH

Securely block up the attachment before working underneath.

1. Raise the snow blade off the ground. Position a jackstand (Item 1) under the blade. Lower the blade until it rests securely on the jackstand.
2. Stop the engine and exit the machine. See page 16.
3. Remove the cotter pin (Item 2) and the cylinder pin (Item 3).
4. Remove the nut (Item 4), bolt (Item 5) and the spacer (Item 6) from the cylinder (Item 7).
5. Slide the cylinder (Item 7) out. Mark the location of and disconnect the hydraulic hoses from the cylinder.

Installation

1. Position the cylinder (Item 7) so the hydraulic hoses can be reinstalled on the cylinder and tightened.
2. Install the cylinder (Item 7) into the frame.
3. Align the cylinder base end. Install the bushing (Item 6), the bolt (Item 5) and nut (Item 4). Tighten to 20-24 ft.-lbs. (27-32 Nm) torque.
4. Align the rod end of the cylinder to the frame and install the pin (Item 3) and the cotter pin (Item 2).
5. Enter the utility vehicle and start the engine. See page 16.
6. Raise the blade and remove the jackstand. Fully lower the blade to the ground.
7. Stop the engine and exit the vehicle. See page 16.

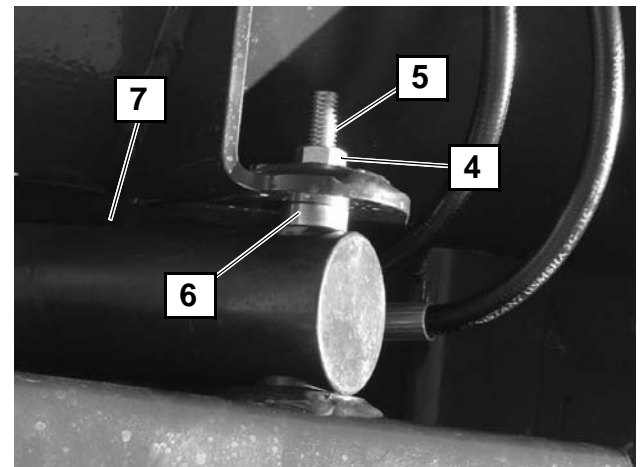
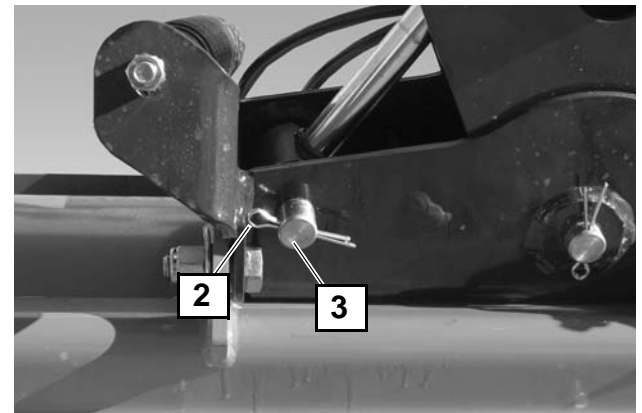
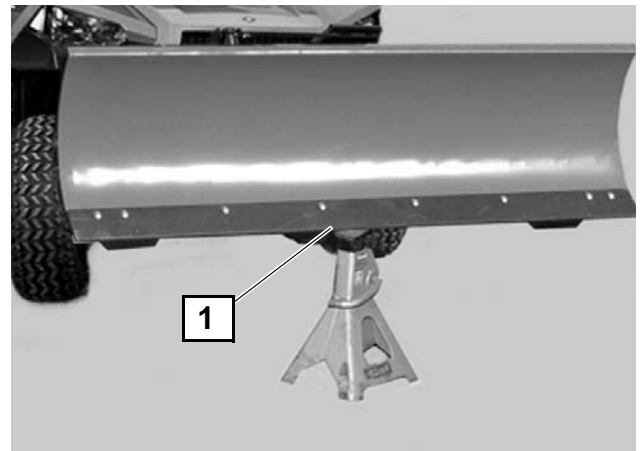

MAINTENANCE

Hydraulic Cylinder Disassembly And Assembly

1. Nut
2. O-ring
3. Seal
4. Piston
5. Back-up Ring
6. Seal
7. Head
8. Rod

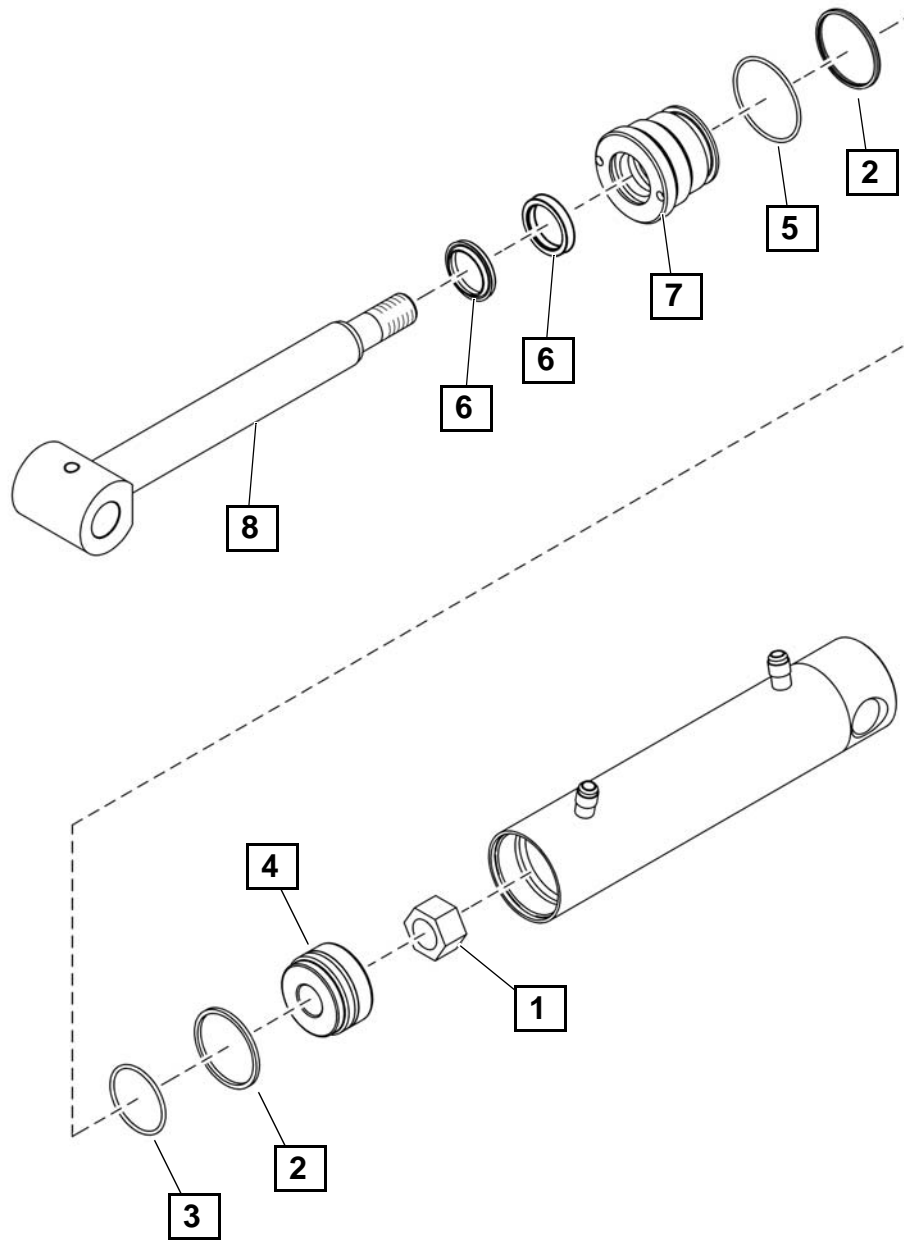

Hydraulic Cylinder Disassembly And Assembly

NOTE: When repairing hydrostatic and hydraulic systems, clean the work area before disassembly and keep all parts clean. Always use caps and plugs on hoses, tubelines and ports to keep dirt out. Dirt can quickly damage the system.

NOTE: Contain and dispose of any oil leakage in an environmentally safe manner.

WARNING!

AVOID INJURY OR DEATH

Wear safety glasses to prevent eye injury when any of the following conditions exist:

- When fluids are under pressure.
- Flying debris or loose material is present.
- Engine is running.

NOTE: The drawings may not show the cylinder exactly as it appears but the procedure is correct for the cylinder.

Use the following tools to disassemble and assemble the hydraulic cylinder:

PU-51107 O-ring Seal Hook

PU-51293 Seal Installation Tool

PU-51292 Rod Seal Installation Tool

PU-51108 Adjustable Gland Nut Wrench

Torque Wrench

Disassembly

1. Put the base end of the cylinder in a drain pan and move the rod end in and out to remove the hydraulic fluid from the cylinder.
2. Put the base end of the cylinder in a vise.
3. Use the adjustable gland nut wrench to loosen the head.
4. Remove the rod assembly from the cylinder.
5. Remove the old shear bolt (Item 2) from the base of the angle blade cylinder and remove the bushing (Item 3).
6. Remove the cylinder from the vise.
7. Put the rod end in the vise.
8. Remove the nut from the piston end of the rod.
9. Remove the piston off the rod end.
10. Remove the head (Item 1) from the rod.

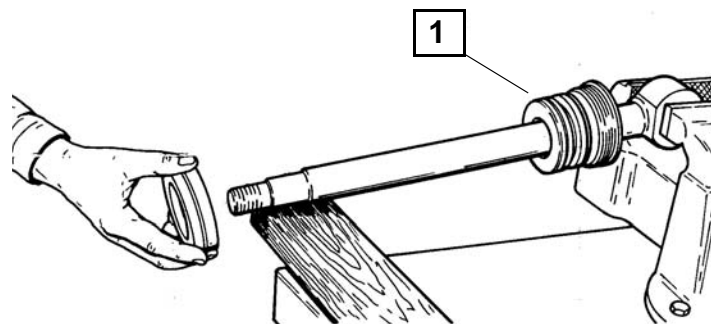
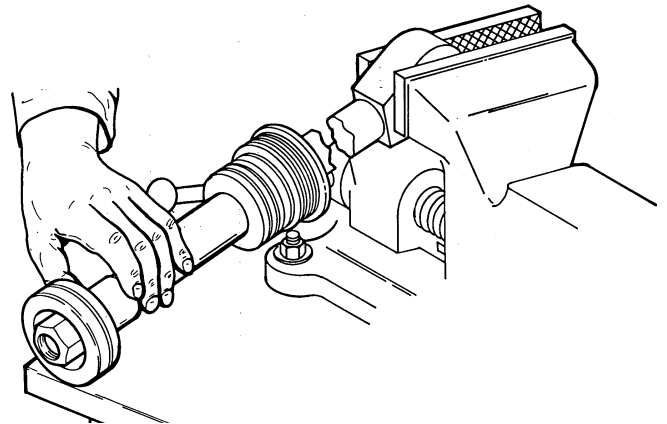
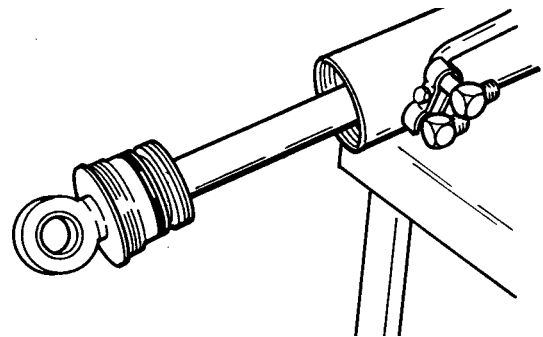
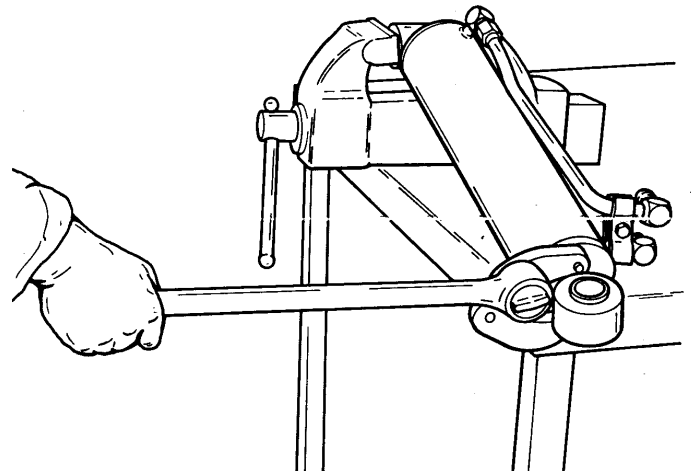

MAINTENANCE

Hydraulic Cylinder Disassembly And Assembly

Disassembly (Cont'd)

11. Remove the O-ring and the back-up ring.
12. Remove the O-ring (Item 1).

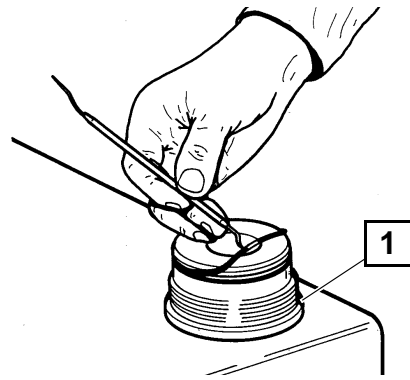

13. Remove the wiper seal from the head.

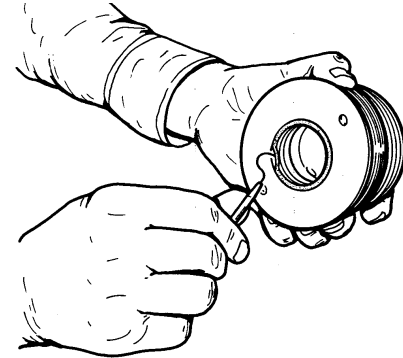

14. Remove the oil seal from the head.

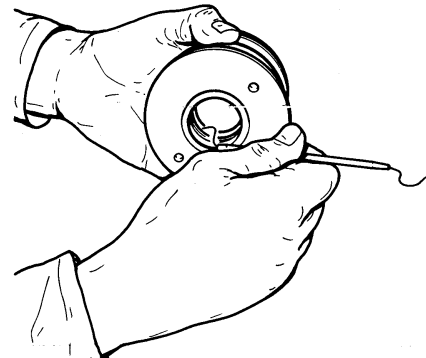

15. Remove the piston seal.

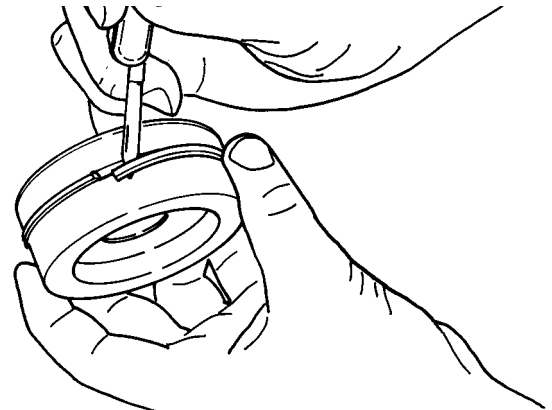

Hydraulic Cylinder Disassembly And Assembly

Disassembly (Cont'd)

16. Remove the O-ring from the piston.

Tip: while repairing the cylinder, use care not to damage the parts. Inspect for nicks, scratches or otherwise damaged or bent parts before assembling the cylinder. Replace parts that appear damaged in any way. The cylinder may not function correctly if there is damage to any of the parts.

Destroy all the O-rings and seals and replace with NEW O-rings and seals

Assembly

1. Install the O-Ring on the piston.

Tip: Do not overstretch the seal.

2. Install the seal on the tool (PU-51293) and stretch the seal until it fits over the piston. Allow the seal to stretch for 30 seconds before removing from the tool and installing on the piston.

3. Remove the piston seal from the tool and install on the piston.

4. Use the ring compressor to compress the seal to the correct size. Leave the piston in the ring compressor for at least 3 minutes.

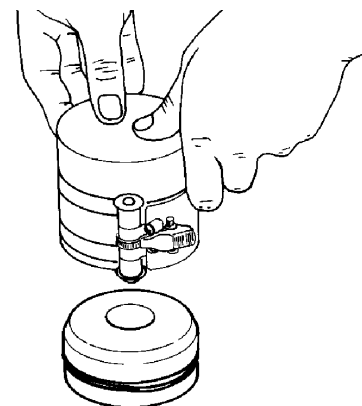
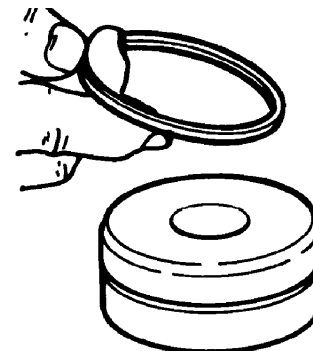
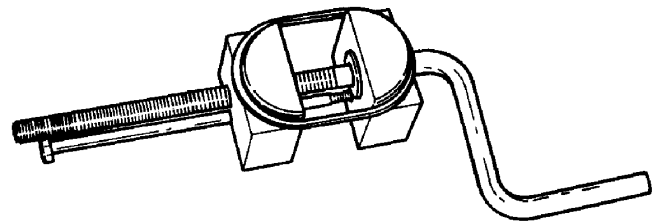
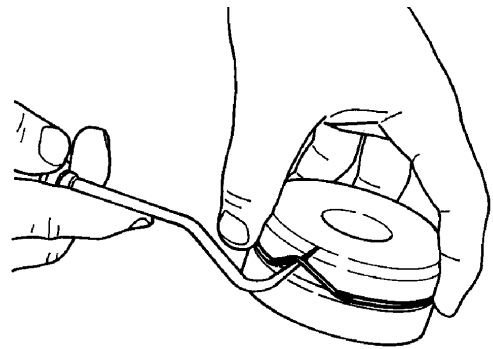

MAINTENANCE

Hydraulic Cylinder Disassembly And Assembly

Assembly (Cont'd)

5. Install the oil seal into the head.

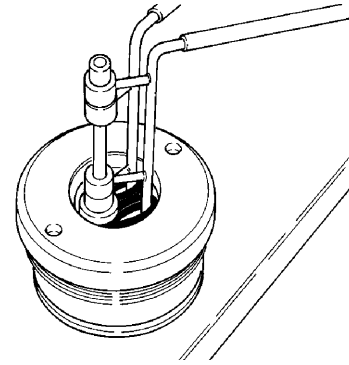

6. Install the wiper seal with the lip toward the outside of the head.

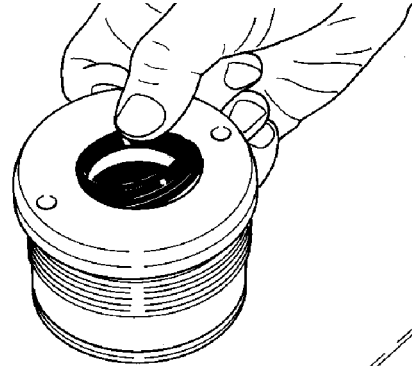

7. Install the O-ring (Item 1) and install the back-up washer and O-ring on the head.

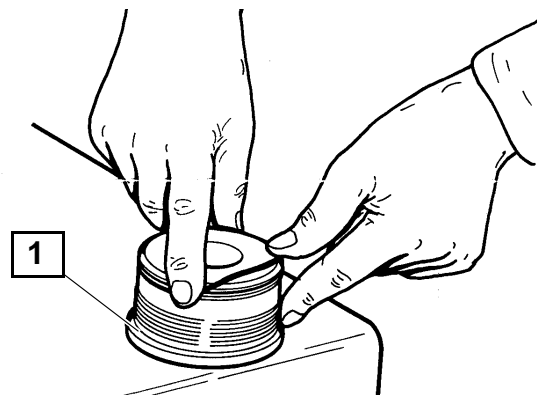

8. Install the head onto the rod.

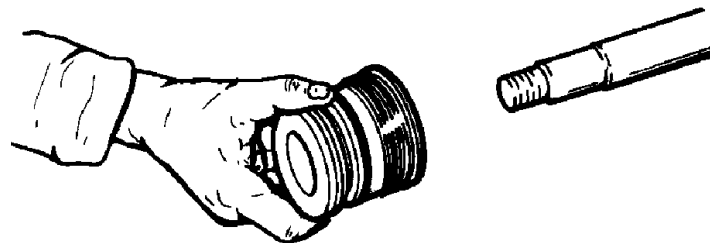

Hydraulic Cylinder Disassembly And Assembly

Assembly (Cont'd)

9. Install the piston on the rod.

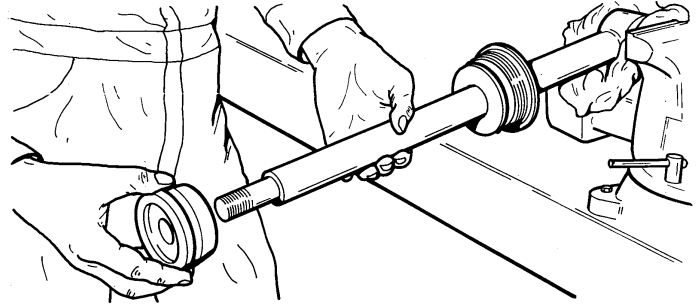

10. Install the nut on the rod. Tighten the nut to 250 ft.-lbs. (339 Nm) torque.

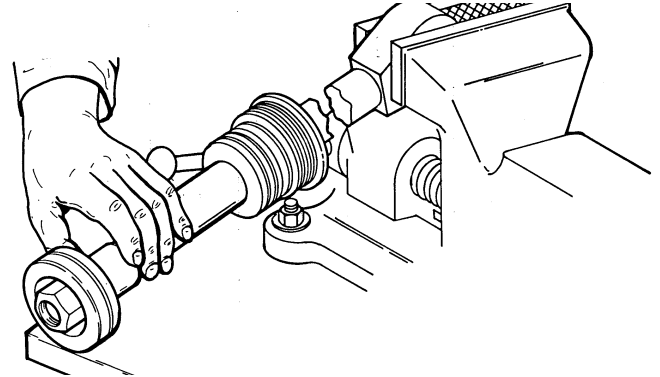

11. Apply clean hydraulic oil to the inside of the cylinder case.

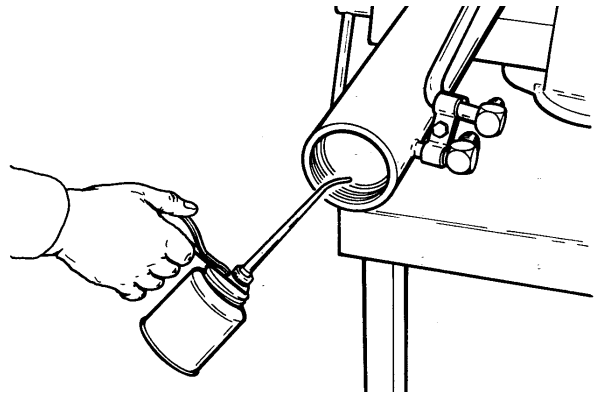

12. Apply clean hydraulic oil to the outer diameter of the piston.

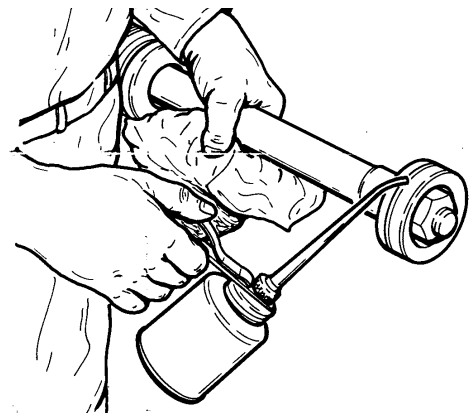

MAINTENANCE

Hydraulic Cylinder Disassembly And Assembly

Assembly (Cont'd)

13. Install the rod into the cylinder case.

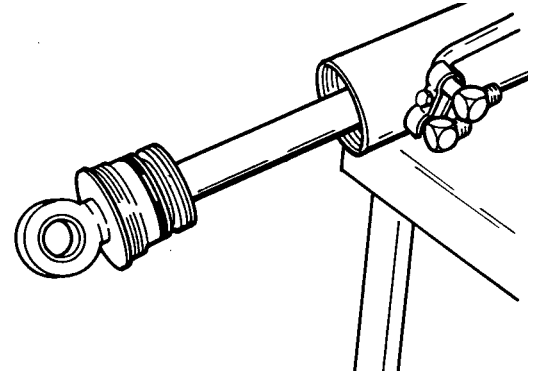

14. Apply clean hydraulic oil to the threads of the cylinder case and to the outer diameter of the head.

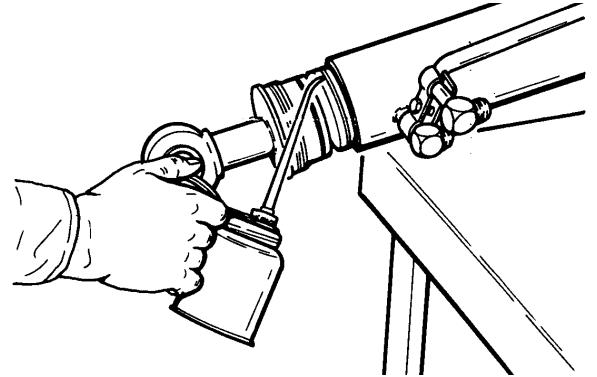

15. Install the head into the cylinder case. Use the adjustable gland nut wrench to tighten the head. Tighten the nut to 200 ft.-lbs. (271 Nm) torque.

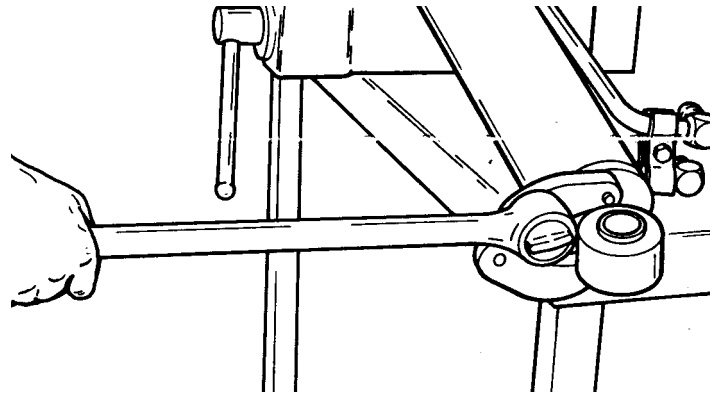

Attachment Storage

Sometimes it may be necessary to store your attachment for an extended period of time. Below is a list of items to perform before storage:

- Thoroughly clean and wash the attachment.
- Lubricate the attachment.
- Inspect the mounting frame, mounting pins and all welds on the attachment for wear and damage.
- Check for loose hardware, missing guards, or damaged parts.
- Replace worn or damaged parts.
- Check for damaged or missing decals. Replace if necessary.
- Place the attachment in a dry protected shelter.
- Place the attachment flat on the ground.

Tip: In muddy conditions or to prevent the attachment from freezing to the ground, put the attachment on planks or blocks before removing the attachment from the machine.

Return to Service

After the attachment has been in storage, it is necessary to follow a list of items to return the attachment to service:

- Check for damaged or missing decals. Replace if necessary.
- Be sure all shields and guards are in place.
- Lubricate the attachment.
- Check for loose hardware, missing or damaged parts.
- Check for leaks. Repair as needed.
- Install and operate attachment, check for correct function.

POLARIS PRODUCTS

Part Number	Description
Grease / Specialized Lubricants	
2871312	Grease Gun Kit, Premium All Season
2871322	Premium All Season Grease (3 oz./89 ml cartridge)
2871423	Premium All Season Grease (14 oz./414 ml cartridge)

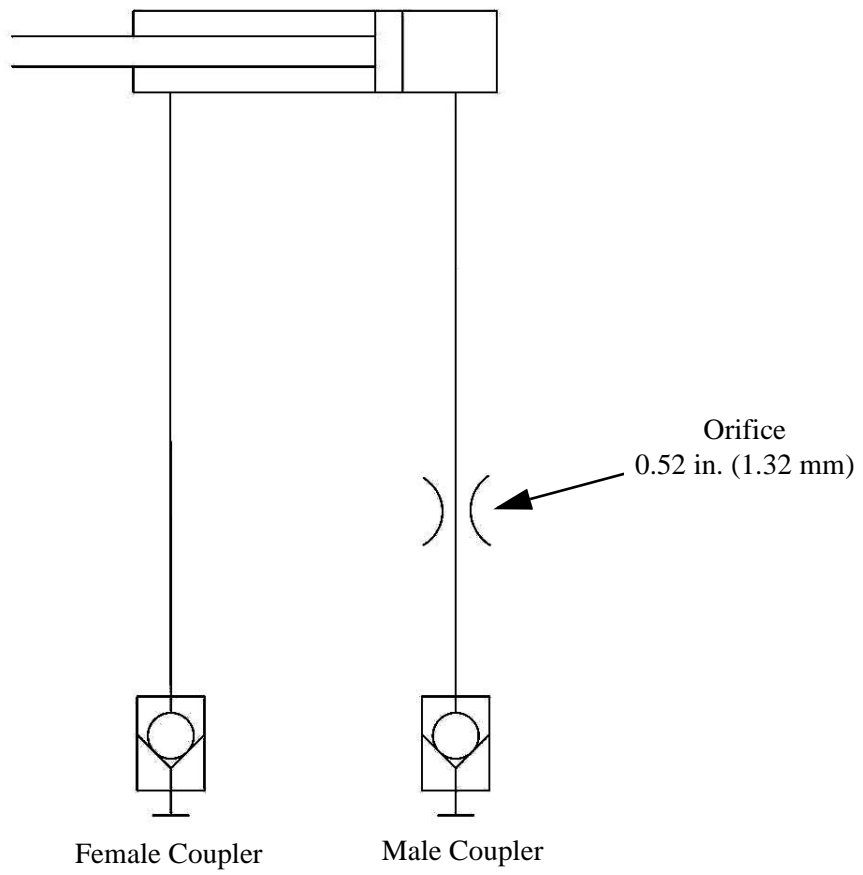

SPECIFICATIONS

Dimensions

- Where applicable, specifications conform to **SAE and ISO** standards and are subject to change without notice

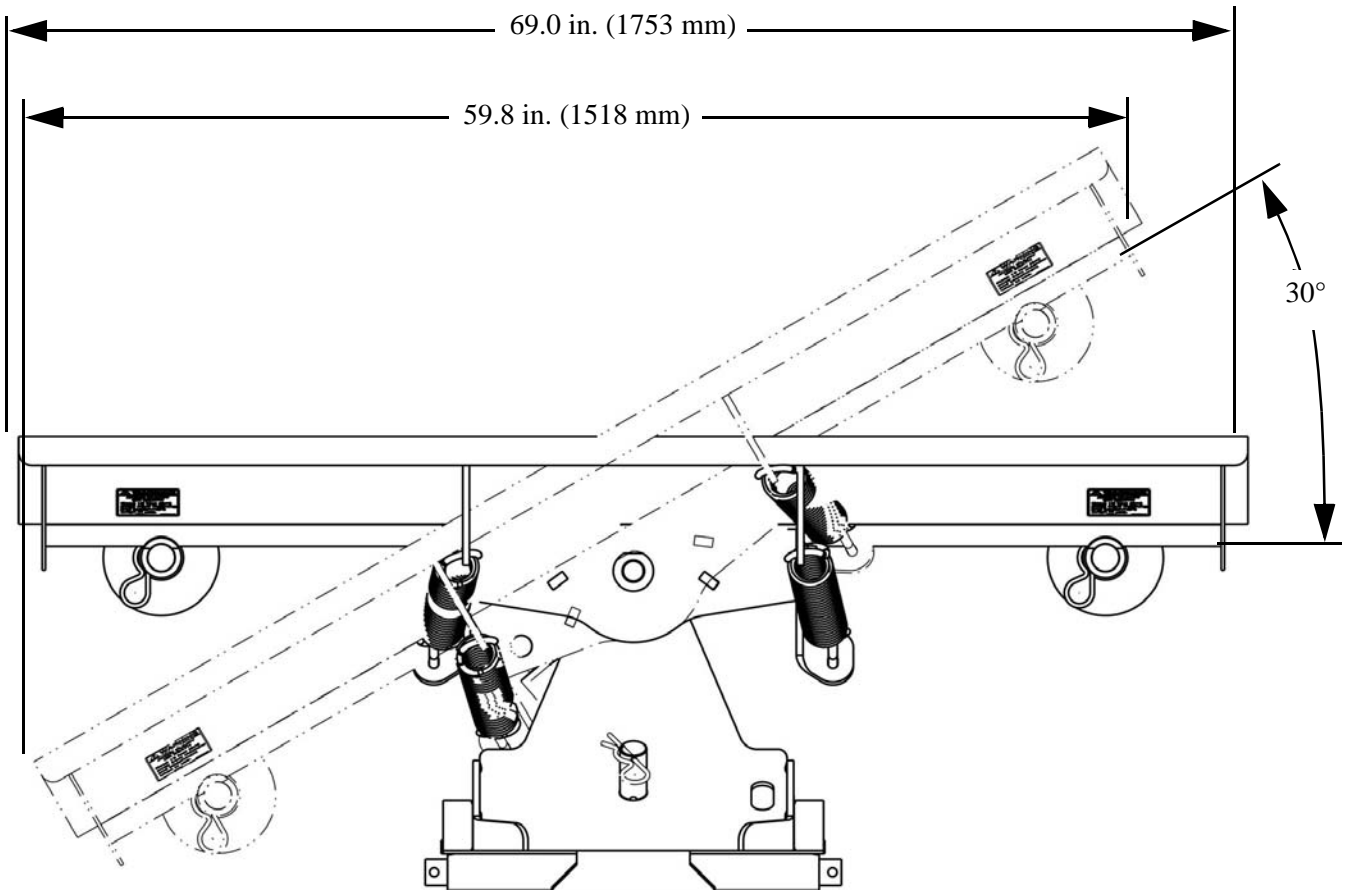
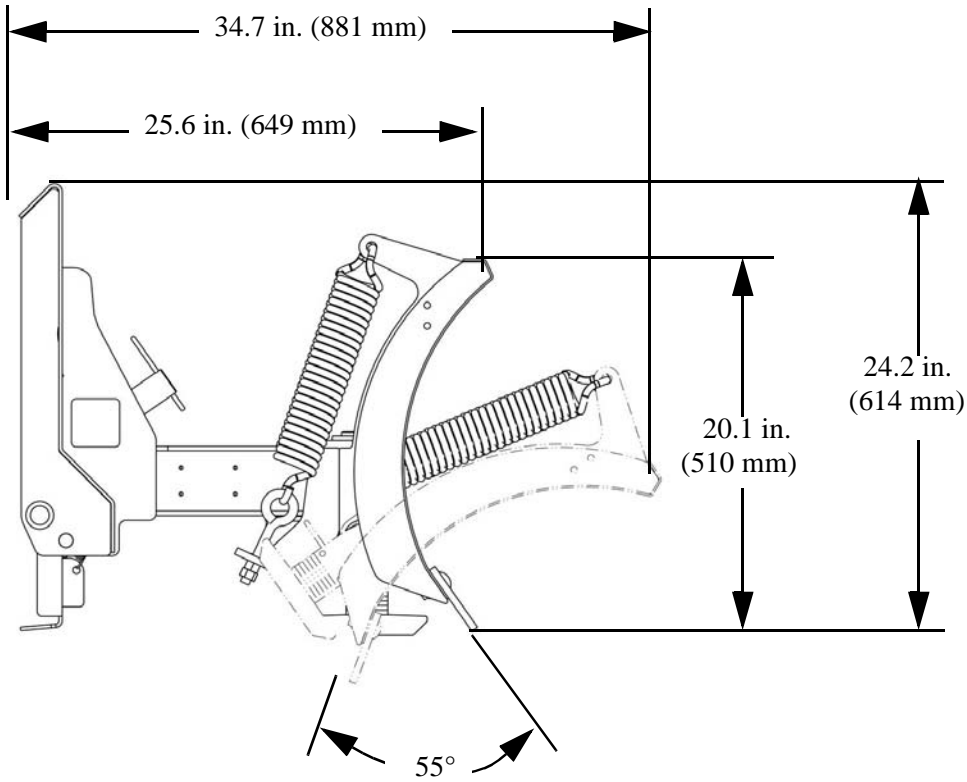

Performance

Weight	275 lbs. (125 kg)
--------	-------------------

BOLT TORQUE

Standard Bolt Torque Specification

Bolt Size	Grade 2 ft-lbs (Nm)	Grade 5 ft-lbs (Nm)	Grade 8 ft-lbs (Nm)
1/4-20	5 (7)	8 (11)	12 (16)
1/4-28	6 (8)	10 (14)	14 (19)
5/16-18	11 (15)	17 (23)	25 (35)
5/16-24	12 (16)	19 (26)	29 (40)
3/8-16	20 (27)	30 (40)	45 (62)
3/8-24	23 (32)	35 (48)	50 (69)
7/16-14	30 (40)	50 (69)	70 (97)
7/16-20	35 (48)	55 (76)	80 (110)
1/2-13	50 (69)	75 (104)	110 (152)
1/2-20	55 (76)	90 (124)	120 (166)

Metric Bolt Torque Specification

Bolt Size	GRADE				
	4.6	4.8	8.8/8.9	10.9	12.9
	FT-LBS / NM (DRY THREADS)				
M3	.3/5	.5/7	1/1.3	1.5/2	1.5/2
M4	.8/1.1	1/1.5	2/3	3/4.5	4/5
M5	1.5/2.5	2/3	4.5/6	6.5/9	7.5/10
M6	3/4	4/5.5	7.5/10	11/15	13/18
M8	7/9.5	10/13	18/25	26/35	33/45
M10	14/19	18/25	37/50	55/75	63/85
M12	26/35	33/45	63/85	97/130	110/150
M14	37/50	55/75	103/140	151/205	177/240
M16	59/80	85/115	159/215	232/315	273/370
M18	81/110	118/160	225/305	321/435	376/510

HYDRAULIC CONNECTION SPECIFICATIONS

Straight Thread O-ring Fitting

NOTE: When repairing hydrostatic and hydraulic systems, clean the work area before disassembly and keep all parts clean. Always use caps and plugs on hoses, tubelines and ports to keep dirt out. dirt can quickly damage the system.

NOTE: Contain and dispose of any oil leakage in an environmentally safe manner.

Lubricate the O-ring before installing the fitting. Loosen the jam nut and install the fitting. Tighten the jam nut until the washer is tight against the surface.

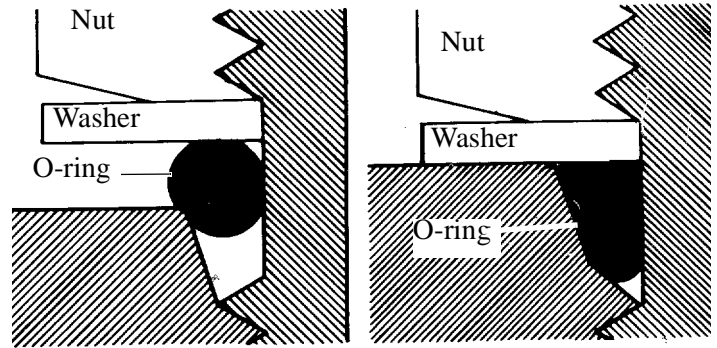

Straight Thread O-ring Fitting

Replace any tubelines that are bent or flattened. they will restrict flow, which will slow hydraulic action and can cause heat.

Replace hoses which show signs of wear, damage or weather cracked rubber.

Always use two wrenches when loosening and tightening hoses and tubeline fittings.

Flared Fitting

Use the following procedure to tighten the flare fittings:

Tighten the nut until it makes contact with the seat. Make a mark across the flats of both the male and female parts of the connection (Item 1).

Use the chart below to find the correct tightness needed (Item 2). If the fitting leaks after tightening, disconnect and inspect the seat area for damage.

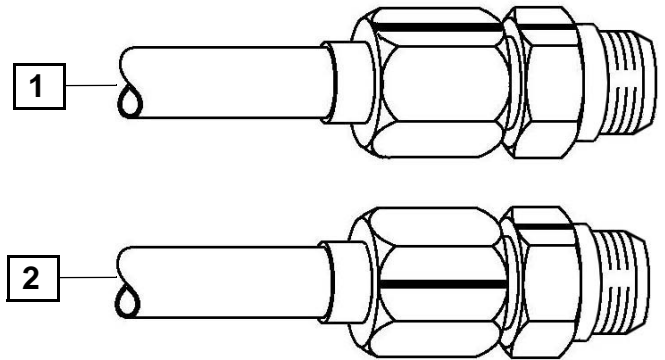

Flare Fitting Tightening Torque		
Tubeline Outside Diameter	Thread Size	Torque Ft-lbs (Nm)
1/4 inch	7/16 inch - 20	13 (18)
5/16 inch	1/2 inch - 20	17 (23)
3/8 inch	9/16 inch - 18	22 (30)
1/2 inch	3/4 inch - 16	40 (54)
5/8 inch	7/8 inch - 14	60 (81)
3/4 inch	1-1/16 inch - 12	84 (114)
7/8 inch	1-3/16 inch - 12	98 (133)
1.0 inch	1-5/16 inch - 12	118 (160)
1-1/4 inch	1-5/8 inch - 12	154 (209)
1-1/2 inch	1-7/8 inch - 12	163 (221)
2.0 inch	2-1/2 inch - 12	252 (342)

POLARIS ATTACHMENT LIMITED WARRANTY

LIMITED WARRANTY

POLARIS Sales Inc., 2100 Highway 55, Medina, MN 55340 (POLARIS) gives a 12-month LIMITED WARRANTY for all components of your POLARIS Attachment against defects in material or workmanship. This warranty covers parts and labor charges for repair or replacement of defective parts and begins on the date of purchase. This warranty is limited to the original retail purchaser and is not transferable. The duration of this warranty may vary by international region based upon local laws and regulations.

WARRANTY COVERAGE LIMITATIONS AND EXCLUSIONS

This POLARIS limited warranty excludes any failures that are not caused by a defect in material or workmanship. **THIS WARRANTY DOES NOT COVER CLAIMS OF DEFECTIVE DESIGN.**

This warranty also does not cover: 1) acts of God, accidental damage, normal wear and tear, abuse or improper handling; 2) scheduled service and general wear items, consumable components, or any parts exposed to friction surfaces, stresses, environmental conditions and/or contamination for which they were not designed or not intended, including engine and hydraulic components and fluids; and 3) any component or part that has been altered structurally, modified, neglected, improperly maintained, or used for purposes other than for which it was designed.

This warranty excludes damages or failures resulting from improper attachment or installation; airflow obstructions; operator error or abuse; accidents; use of the attachment on any vehicle or equipment not approved by Polaris; failure to maintain or use the attachment as provided in the applicable instructions; or repairs made by an unauthorized repair center.

Mixing brands of hydraulic fluids or using non-recommended hydraulic fluids may cause damage to attachments. We recommend the use of POLARIS hydraulic fluids. Damage or failure resulting from the use of non-recommended lubricants or hydraulic fluids is not covered by this warranty.

The warranty provides no coverage for personal loss or expense, including mileage, transportation costs, hotels, meals, shipping or handling fees, product pick-up or delivery, replacement rentals, loss of product use, loss of profits, or loss of vacation or personal time.

THE EXCLUSIVE REMEDY FOR BREACH OF THIS WARRANTY SHALL BE, AT POLARIS' OPTION, REPAIR OR REPLACEMENT OF ANY DEFECTIVE MATERIALS, COMPONENTS, OR PRODUCTS. THE REMEDIES SET FORTH IN THIS WARRANTY ARE THE ONLY REMEDIES AVAILABLE TO ANY PERSON FOR BREACH OF THIS WARRANTY. POLARIS SHALL HAVE NO LIABILITY TO ANY PERSON FOR INCIDENTAL, CONSEQUENTIAL OR SPECIAL DAMAGES OF ANY DESCRIPTION, WHETHER ARISING OUT OF EXPRESS OR IMPLIED WARRANTY OR ANY OTHER CONTRACT, NEGLIGENCE, OR OTHER TORT OR OTHERWISE. THIS EXCLUSION OF CONSEQUENTIAL, INCIDENTAL, AND SPECIAL DAMAGES IS INDEPENDENT FROM AND SHALL SURVIVE ANY FINDING THAT THE EXCLUSIVE REMEDY FAILED OF ITS ESSENTIAL PURPOSE.

THE IMPLIED WARRANTY OF FITNESS FOR A PARTICULAR PURPOSE IS EXCLUDED FROM THIS LIMITED WARRANTY. ALL OTHER IMPLIED WARRANTIES (INCLUDING BUT NOT LIMITED TO THE IMPLIED WARRANTY OF MERCHANTABILITY) ARE LIMITED IN DURATION TO THE ABOVE 12-MONTH WARRANTY PERIOD. POLARIS DISCLAIMS ALL EXPRESS WARRANTIES NOT STATED IN THIS WARRANTY. Some states do not permit the exclusion or limitation of incidental or consequential damages or allow limitations on the duration of implied warranties, so the above limitations may not apply to you if inconsistent with controlling state law.

Please work with your dealer to resolve any warranty issues. Should your dealer require any additional assistance they will contact the appropriate person at POLARIS. This warranty gives you specific legal rights, and you may also have other rights which vary from state to state. If any of the above terms are void because of federal, state, local law, all other warranty terms will remain in effect.

For questions call POLARIS Customer Assistance:

United States: 1-888-704-5290

Canada: 1-204-925-7100

MAINTENANCE LOG

Use the following chart to record periodic maintenance.

DATE	MILES (KM) OR HOURS	TECHNICIAN	SERVICE PERFORMED / COMMENTS

MAINTENANCE LOG

Use the following chart to record periodic maintenance.

DATE	MILES (KM) OR HOURS	TECHNICIAN	SERVICE PERFORMED / COMMENTS

A	
Adjusting Deflector	22
Adjusting Drive Chain	36
Adjusting the Skid Shoe	22, 36
Attachment Component Locations	11
Attachment Mounting Frame	14
Attachment Storage	41

C	
Capacity	44
Chain Adjustment	36
Changing Gearbox Fluid	38
Cleaning Discharge Chute	27
Cleaning Snow Blade	35
Component Locations	11
Controls	21
Controls, Float	21
Couplers	20

D	
Deflector Adjustment	22
Disconnecting Couplers	20

E	
Entering	16
Entering and Exiting	16
Equipment Modifications	9
Exiting	16

F	
Fastening BRUTUS and Attachment on Trailer	31
Float	21
Fluid Capacity	44

G	
Gearbox Fluid Change	38
Grease Points	37
Greasing The Attachment	37

H	
Hydraulic Quick Couplers	20

I	
Installing Chute Slide	40
Installing Couplers	20
Installing Cutting Edge	40
Installing Skid Shoe	39
Installing the PTO	19
Installing the Snow blade	17
Introduction	4

L	
Leveling The Snow Blade	18
Lifting The Attachment	30
Loading Onto Trailer	31
Lowering the Attachment	21
Lubrication	37

M	
Maintenance Log	46
Modifications to Vehicle	9
Mounting Frame	13

O	
Operator Safety	8, 9

P	
Performance	44
Power Take-Off	19
Protective Eyewear	9
PTO	19
PTO Controls	24
PTO Driveline	13

R	
Raising the Attachment	21
Removing Chute Slide	40
Removing Cutting Edge	40
Removing the PTO	19
Removing The Snow Blade	28
Return To Service	41

S	
Safety Labels	6, 7
Safety Symbols	4
Safety Warnings	8, 9
Seat Belt	9, 16
Signal Words	4
Skid Shoe Adjustment	22, 36
Skid Shoe Replacement	39
Snow Blade Dimensions	44
Snow blade Mounting Frame	13
Snow Blade Removal	28
Snow Blade Specifications	44
Snow Blade Storage	41
Standard Items	12
Storage	41
Storing the Attachment	41

V	
Vehicle Identification Number	5

W	
Warnings	4
Warranty	48
Weight of Snow Blade	45
Welcome	1
Width of Snow Blade	44

WARNING

Improper vehicle use can result in SEVERE INJURY or DEATH

NEVER Operate:

- At speeds too fast for your skills or the conditions.
- After or while using Alcohol or Drugs.
- On hills steeper than 15 degrees $\leq 15^\circ$
- On public roads, a collision can occur with another vehicle.
- With passengers under age twelve or who cannot comfortably reach the floor and hand holds.
- With unapproved accessories - they may seriously affect stability.

ALWAYS:

- Wear your seat belt. Vehicle rollover could cause severe injury or death.
- Wear eye protection and keep hands and feet in vehicle at all times.
- Reduce speed and use extra caution when carrying passengers.
- Avoid sharp turns or turns while applying heavy throttle.
- Operate slowly in reverse - avoid sharp turns or sudden braking.
- Make sure passenger reads and understands all safety signs.
- Watch for branches or other hazards that could enter vehicle.

READ OWNER'S MANUAL.

FOLLOW ALL INSTRUCTIONS AND WARNINGS.



For your nearest Polaris dealer,
call 1-800-POLARIS (765-2747)
or visit www.polaris.com
Polaris Industries Inc.
2100 Hwy. 55
Medina, MN 55340
Part No. 9924406 Rev 02
Printed in USA

