

**TERRAIN
DOMINATION**



POLARIS®

AXYS



2015 600 / 800 RUSH®
2015 600 / 800 SWITCHBACK®

Snowmobile Owner's Manual
for Maintenance and Safety

IMPORTANT NOTICE TO OWNER

Modifications to this snowmobile are not recommended and may result in voided warranty coverage. Please read the warranty section of this manual carefully.

⚠ WARNING

Read, understand, and follow all of the instructions and safety precautions in this manual and on all product labels.

Failure to follow the safety precautions could result in serious injury or death.

⚠ WARNING

The engine exhaust from this product contains chemicals known to the State of California to cause cancer, birth defects or other reproductive harm.



For videos and more information about a safe riding experience with your Polaris vehicle, scan this QR code with your smartphone.

WELCOME

Thank you for purchasing a POLARIS vehicle, and welcome to our world-wide family of POLARIS enthusiasts. Be sure to visit us online at www.polaris.com for the latest news, new product introductions, upcoming events, career opportunities and more.

Here at POLARIS we proudly produce an exciting line of utility and recreational products.

- Snowmobiles
- All-terrain vehicles (ATVs)
- Low emission vehicles (LEVs)
- *RANGER*® utility vehicles
- *RZR*® sport vehicles
- *VICTORY*® motorcycles
- *GEM*® vehicles

We believe POLARIS sets a standard of excellence for all utility and recreational vehicles manufactured in the world today. Many years of experience have gone into the engineering, design, and development of your POLARIS vehicle, making it the finest machine we've ever produced.

For safe and enjoyable operation of your vehicle, be sure to follow the instructions and recommendations in this owner's manual. Your manual contains instructions for minor maintenance, but information about major repairs is outlined in the POLARIS Service Manual and should be performed only by a factory certified Master Service Dealer® (MSD) technician.

Your POLARIS dealer knows your vehicle best and is interested in your total satisfaction. Be sure to return to your dealership for all of your service needs during, and after, the warranty period.



POLARIS®

The following are trademarks of POLARIS Industries Inc.:

POLARIS®	AXYS™	SWITCHBACK®
PERC®	RUSH®	SWITCHBACK ADVENTURE®
LOCK & RIDE®		

Copyright 2014 POLARIS Industries Inc. All information contained within this publication is based on the latest product information at the time of publication. Due to constant improvements in the design and quality of production components, some minor discrepancies may result between the actual vehicle and the information presented in this publication. Depictions and/or procedures in this publication are intended for reference use only. No liability can be accepted for omissions or inaccuracies. Any reprinting or reuse of the depictions and/or procedures contained within, whether whole or in part, is expressly prohibited.

The original instructions for this vehicle are in English. Other languages are provided as translations of the original instructions.

Printed in U.S.A.

2015 600/800 AXYS Snowmobile Owner's Manual

P/N 9925073

TABLE OF CONTENTS

Introduction	5
This section contains helpful information for owners and drivers and illustrates the location of important identification numbers that should be recorded in the owner's manual.	
Safety	9
This section describes safe vehicle operation and identifies warning labels and their locations.	
Features	26
This section identifies the locations of your snowmobile's controls and features.	
The Perfect Fit	51
This section includes a Suspension Quick Set-Up Guide and explains how to make additional suspension adjustments for the perfect riding experience.	
Pre-Ride Inspections	66
This section explains procedures that must be performed before riding.	
Operation	73
This section explains proper engine break-in, operation of features and general operating procedures.	
Maintenance	87
This section defines your role, and your dealer's role, in your snowmobile's regular maintenance.	
POLARIS Products	137
Specifications	138
Troubleshooting	158
Warranty	163
Maintenance Log	171
Index	174

INTRODUCTION

Important Notes for Owners and Drivers

After reading this manual, store it in the snowmobile for convenient reference. It should remain with the snowmobile when the snowmobile is sold.

Some of the illustrations and photos used in this manual are general representations. Your model may differ.

Follow the maintenance program outlined in this manual. Preventive maintenance ensures that critical components of the snowmobile are inspected by your dealer at specific mileage intervals.

You and your dealer must complete the registration form included with your snowmobile and forward it to us. This completed form is necessary to ensure warranty coverage.

Protect and preserve your right to ride by joining your local trail riding clubs.

When teaching inexperienced operators to ride, set up a predetermined course for practice. Make sure they know how to drive and control the snowmobile before allowing them to make longer trips. Teach them proper snowmobile courtesy, and enroll them in driver's training and safety courses sponsored by local or state organizations.

INTRODUCTION

Preservation of the Environment

POLARIS is committed to supporting an environmental education campaign. We encourage state and provincial governments across the snowbelt to adopt rigorous safety training programs that encourage protection of our environment, including wildlife and vegetation.

Snowmobile clubs and other organizations are working together to protect our environment. Please support their efforts and operate your snowmobile with consideration for the protection and preservation of our environment.

Noise Level

One of the most publicized issues about snowmobiles is noise. The Society of Automotive Engineers (SAE), the standard-setting body for snowmobile development, recommends that snowmobiles conform to prescribed sound levels.

POLARIS snowmobiles are engineered to conform to these SAE standards. Our muffler systems are designed to reduce noise levels and must not be altered or removed. The sound of your snowmobile may not be welcome to non-snowmobilers, so you have a responsibility to operate your snowmobile with concern for others. We do our part by manufacturing quieter machines; we ask your help to further reduce the impact of noise by operating your snowmobile safely and responsibly.

Air Pollution

POLARIS engineers continuously investigate ways to reduce emission levels of two-stroke engines. We expect our efforts to lead to the reduction of potential air pollution.

In addition to our technological research, we encourage government agencies, manufacturers, distributors, dealers, ecologists, and other interested parties to work together to develop data on environmental topics.

INTRODUCTION

Vehicle Identification Numbers

Record your snowmobile's identification numbers and key number in the spaces provided.

NOTE: The Vehicle Identification Number (VIN) is stamped into the side of the tunnel and printed on the tunnel VIN label.

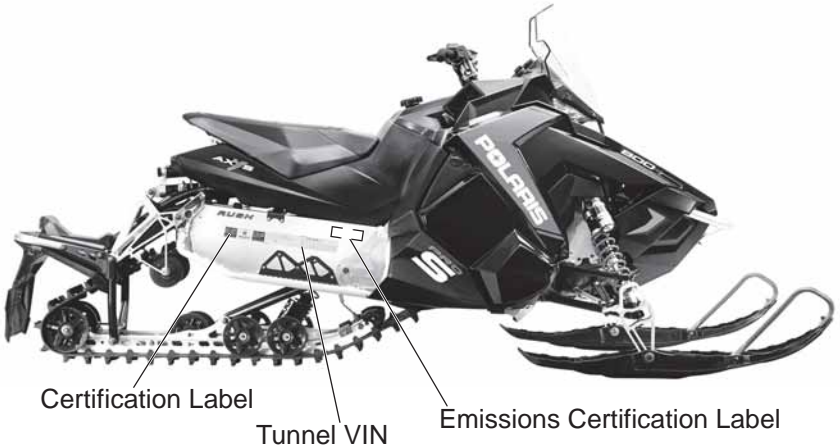

Vehicle Model Number: _____

Tunnel VIN (right side of tunnel): _____

Engine Serial Number (on recoil housing): _____

Key Number: _____

NOTICE: If installing an aftermarket tunnel wrap, do not cover the tunnel certification, tunnel VIN or emissions certification labels with the wrap. If the tunnel wrap doesn't provide an opening for these labels, remove the section of wrap where the labels are located.

INTRODUCTION

Engine Serial Number

The engine serial number is located on the identification label on the engine recoil cover.

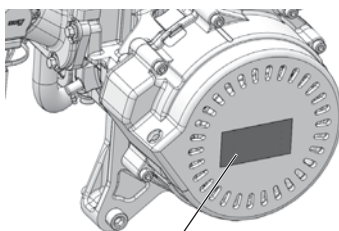

Engine Serial Number

Key Identification

The ignition keys are etched with an identification number. Remove the spare key and store it in a safe place. Your key can be duplicated only by mating a POLARIS key blank using the same identification number with one of your existing keys, so if both keys are lost, the ignition switch assembly must be replaced.



Key Identification Number

Operator Safety

The following signal words and symbols appear throughout this manual and on your vehicle. Your safety is involved when these words and symbols are used. Become familiar with their meanings before reading the manual.



The safety alert symbol indicates a potential personal injury hazard.

DANGER

A **DANGER** indicates a hazardous situation that, if not avoided, will result in death or serious injury.

WARNING

A **WARNING** indicates a hazardous situation that, if not avoided, could result in death or serious injury.

CAUTION

A **CAUTION** indicates a hazardous situation that, if not avoided, could result in minor or moderate injury.

NOTICE

A **NOTICE** indicates a situation that could result in property damage.



The Prohibition Safety Sign indicates an action **NOT** to take in order to avoid a hazard.



The Mandatory Action Sign indicates an action that **NEEDS** to be taken to avoid a hazard.

SAFETY

Operator Safety

Follow the recommended maintenance program beginning on page 88 of this manual to ensure that all critical components on the snowmobile are thoroughly inspected by your dealer at specific mileage intervals.

WARNING

Driving a snowmobile requires your full attention. **DO NOT** drink alcohol or use drugs or medications before or while driving or riding as a passenger. They will reduce your alertness and slow your reaction time.

Snowmobiles are capable of traveling at high speeds. Use extra caution to ensure operator safety. Make sure your snowmobile is in excellent operating condition at all times. Always check major and vital safety components before every ride.

All POLARIS snowmobiles are designed and tested to provide safe operation when used as directed. Failure of critical machine components may result from operation with any modifications, especially those that increase speed or power. **DO NOT MODIFY YOUR MACHINE.** The snowmobile may become aerodynamically unstable at speeds higher than those for which it is designed. Loss of control may occur at higher speeds. Modifications may also create a safety hazard and lead to bodily injury.

The warranty on your entire machine is terminated if any equipment has been added, or any modifications have been made, to increase the speed or power of the snowmobile.

Operator Safety

Stay Clear of Track

Your snowmobile is propelled by a revolving track that must be partially exposed for proper operation. Do not stand on the plastic flap.

WARNING! Serious injuries may result if hands, feet, or clothing become entangled in the track. Be alert when riding, and remain properly seated to stay clear of the track. Never hold the snowmobile up or stand behind it while warming up the track. A loose track or flying debris could cause serious injury or death. We recommend having your dealer perform all track service and alignment procedures.

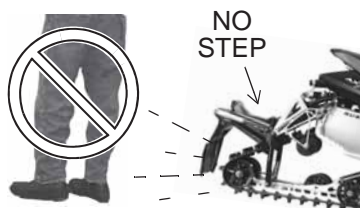

Stay Clear of Engine

Never attempt adjustments with the engine running. Stop the engine before opening a side panel. Always ensure that the hood and side panels are installed and securely latched before starting the engine.

WARNING! Serious injury can occur if fingers or clothing contact the moving parts of an engine. Always stop the engine before attempting adjustments.

Riding Position

Operating a snowmobile requires skill and balance for proper control. Rider positions may vary with experience and the features available on some snowmobiles, but under many conditions, the proper position is to be seated with both feet on the running boards and both hands on the handlebar grips for proper throttle, brake and steering control.

WARNING! Improper riding position may reduce control and could result in serious injury or death. Always ride in a position that allows for control of your vehicle.

SAFETY

Operator Safety

Riding Apparel

Helmet

Wearing a helmet can prevent a severe head injury. Whenever riding a POLARIS vehicle, always wear a helmet that meets or exceeds established safety standards.

Approved helmets in the USA and Canada bear a U.S. Department of Transportation (DOT) label.

Approved helmets in Europe, Asia and Oceania bear the ECE 22.05 label. The ECE mark consists of a circle surrounding the letter E, followed by the distinguishing number of the country which has granted approval. The approval number and serial number will also be displayed on the label.

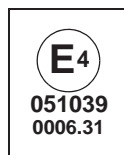

Eye Protection

Do not depend on eyeglasses or sunglasses for eye protection. Whenever riding a POLARIS vehicle, always wear shatterproof goggles or use a shatterproof helmet face shield. POLARIS recommends wearing approved Personal Protective Equipment (PPE) bearing markings such as VESC 8, V-8, Z87.1, or CE. Make sure protective eye wear is kept clean.

Clothing

Be prepared, be warm and be comfortable when riding. Be aware of the weather forecast, especially the windchill, and dress accordingly. See the chart on page 21.

WARNING! Avoid wearing loose clothing or long scarves, which can become entangled in moving parts and cause serious injury. Always wear an approved helmet and eye protection.



Operator Safety

Disabled Operators

Safe operation of this rider-active vehicle requires good judgement and physical skills. Operators with cognitive or physical disabilities have an increased risk of loss of control, which could result in serious injury or death.

Survival Preparation

For your safety, always ride in a group of other snowmobilers. Always tell someone where you're going and how long you expect to be gone. If it isn't possible to ride with others, and you must travel into remote areas, always carry survival equipment that's appropriate to the conditions you may encounter. Such equipment may include, but is not limited to: extra clothing, a sleeping bag, a flashlight, food and water, a signaling mirror, a means of building a fire and a two-way radio or cellular telephone.

Always carry the owner's manual on your snowmobile. For added protection, purchase and carry the following items on your snowmobile as well:

- Spare Drive Belt
- Extra Set of Spark Plugs
- Tow Rope
- Extra Oil
- Fuel Deicer
- Winter Survival Kit
- Trail Map
- First Aid Kit
- Tool Kit

SAFETY

Operator Safety

Rider Capacity

This snowmobile is designed for a single rider only. Never carry a passenger on this snowmobile.

Excessive Speed

WARNING! High speed driving, especially at night, could result in serious injury or death. Always reduce speed when driving at night or in inclement weather.

Always observe all state and local laws governing snowmobile operation and speed limits. Always be alert and pay attention to the trail ahead. If your speed is 40 MPH (64 km/h), your snowmobile is traveling about 60 feet (18 m) per second. If you look back for only two seconds, your snowmobile will travel about 120 feet (36 m). If your speed is 60 MPH (96 km/h), your snowmobile will travel about 180 feet (55 m) in two seconds.

Traveling at night requires extra caution. Check headlight and taillight to ensure proper operation, and don't over-drive your headlight beam. Always be able to bring your snowmobile to a stop in the distance illuminated by the headlight.

Operator Safety Driver Awareness

Slow down when traveling near poles, posts, or other obstacles. Be especially alert if you're snowmobiling after dark. Always be on the alert for wire fences. Single strands are especially dangerous, since there may be a great distance between posts. Guy wires on utility poles are also difficult to distinguish.

Make sure the way is clear before crossing railroads and other roads and highways. The noise of your snowmobile will drown out the sound of approaching vehicles. Look ahead, behind, and to both sides before turning or crossing railroad tracks or highways. Steep embankments may also hide your view. Always leave yourself a way out.



Variations in snow depth and/or water currents may result in uneven ice thickness. You may drown if you break through the ice. Never travel on frozen bodies of water unless you have first verified that the ice is sufficiently thick to support the weight and moving force of the snowmobile, you and your cargo, together with any other vehicles in your party. Always check with local authorities and residents to confirm ice conditions and thickness over your entire route. Snowmobile operators assume all risk associated with ice conditions on frozen bodies of water.

When teaching inexperienced operators to ride, set up a predetermined course for practice. Make sure they know how to drive and control the snowmobile before allowing them to make longer trips. Teach them proper snowmobile courtesy, and enroll them in driver's training and safety courses.

SAFETY

Operator Safety

Avalanches

Snowmobilers should always be properly trained and equipped before traveling in mountainous terrain:

- Take an avalanche class
- Travel with experienced people
- Travel on designated trails
- Make sure each person is equipped with a shovel, probe and avalanche beacon.



You don't have to be snowmobiling on a slope for an avalanche to occur. Be aware that all of the snow is connected. You may be riding on a flat slope or snow covered road, but if the snowpack above is unstable enough you can trigger an avalanche on a steeper slope above you. Always be aware of snow conditions above you as you travel in mountainous terrain.

Before riding in mountainous terrain, call or log on to your local avalanche advisory to get current weather and snow stability information.

For more information about avalanche training and avalanche conditions, contact local law enforcement in your area, or visit the American and Canadian online avalanche centers at www.avalanche.org.

Operator Safety

Ice and Snow Build-up

WARNING! Ice and snow build-up may interfere with the steering of your snowmobile, resulting in serious injury or death. Keep the underhood area free of snow and ice.

Before driving, manually turn the skis to the left and right to be sure ice and snow are not interfering with full left and right steering. If difficulty is encountered, remove ice and snow build-up that may be obstructing the steering linkage.

Driving on Slippery Surfaces

WARNING! Never attempt an abrupt change of direction when operating on slippery surfaces. Proceed slowly and use extra caution. Driving on ice or hard-packed snow reduces steering and braking control, which may result in loss of control and serious injury or death. Slow down and use extra caution when operating on slippery surfaces.

Inadequate Snow Conditions

Since snow provides the only lubrication for the power slide suspension and, on liquid cooled models, cooling for the engine, adequate snow cover is a requirement for operation of your snowmobile.

NOTICE: Driving in too little snow will result in excessive wear and damage to the slide rail, track and/or engine.

WARNING! Inadequate cooling and lubrication will lead to overheating of the slide rail and track, causing premature wear, damage and failure, which can result in serious injury. Reduce speeds and frequently drive into fresh snow to allow adequate cooling and polishing of the slide rail and track surfaces. Avoid operating for prolonged periods on ice, hard-packed surfaces or roads.

Operating in Deep Snow

If the snowmobile becomes stuck in snow, clear the running board area of snow, then step down the snow in front of the snowmobile so that when the throttle is opened, the snowmobile will be able to climb up and over the snow.

SAFETY

Operator Safety

Driving Downhill

When riding downhill, shift your weight to the rear of the snowmobile and reduce your speed to a minimum. Apply just enough throttle to keep the clutch engaged, allowing the engine's compression to help slow the snowmobile and keep it from rolling freely downhill.

WARNING! When driving on long downhill stretches, pump the brakes. Riding the brakes may cause the brake system to overheat, which may result in brake failure. Excessive or repetitive use of the brakes for high speed stops will also cause an overheated brake system. This condition may lead to a sudden loss of brakes and/or fire and may result in serious injury or death.

Driving in Hilly Terrain

WARNING! Climbing a hill or crossing the face of a slope may result in loss of balance and snowmobile rollover, causing serious injury or death. Use caution and good judgement when driving in hilly terrain.

Use extra caution when operating in hilly terrain. If climbing a hill is unavoidable, keep your weight low and forward. If you must cross the face of a slope, keep your weight on the uphill side of the snowmobile to maintain proper balance and avoid possible roll-over.

Slow down when reaching the crest of a hill. Be prepared to react to obstacles, sharp drops or other people or vehicles that may be on the other side of the hill.

If you're unable to continue up a hill, turn the snowmobile downhill before it loses momentum. If this isn't possible, spin the track just enough to dig in to prevent it from rolling back down the hill. Stop the engine and set the parking brake (if equipped). Keeping away from the downhill side of the snowmobile, pull the rear of the snowmobile around and point the front end and skis downhill. Remount the snowmobile, restart the engine, release the parking brake, and descend the hill carefully.

Operator Safety

Drive Belt

Do not operate the engine with the drive belt removed.

Any servicing that requires operation without a belt must be performed by your dealer.

NOTICE: Operation of the engine with the belt removed may result in injury or damage to the engine.

Intake Silencer

Do not operate the engine with the intake silencer or filter removed.

NOTICE: Damage to the engine may occur if the intake silencer or filter are removed.

Clutches

Do not attempt to service the clutches.

All clutch service must be performed by your dealer. The clutch is a complex mechanism that rotates at high speeds. Each clutch is dynamically balanced before installation. Any tampering may disrupt this precision balancing and create an unstable condition.

Cold Weather Drive-Away

Whenever your snowmobile has been parked for a length of time, especially overnight, always make sure the skis and track are loosened from ice and snow before attempting to drive. Apply the throttle with enough authority to put the snowmobile into motion, but always operate within safety limits.

Maneuverability

While much control and maneuverability is achieved through the steering system and skis, maximum control is achieved by the shifting of your body weight. Maneuverability will change for lighter operators or snowmobiles designed to carry a load.

SAFETY

Operator Safety

Driving Responsibly

Every snowmobile handles differently, and even the most docile conditions may become dangerous if operators drive improperly. If you're new to snowmobiling, acquaint yourself with the snowmobile and with what it will and won't do under various conditions. Even seasoned drivers should spend some time getting the feel for a snowmobile before attempting ambitious maneuvers.

- A snowmobile depends on the rider's body position for proper balance in executing turns, traversing hills, etc. Always start on a smooth, level area to begin building your operating experience.
- Before allowing someone else to use your snowmobile, know the extent of their operating skills. Check to see if they've taken a snowmobile safety course and have an operator's certificate. For their protection, as well as yours, make sure they take a snowmobile safety course. Everyone can benefit from the course.
- Don't "jump" your snowmobile over large drifts or similar terrain. Jumping may injure your back because of spinal compression that could occur when the snowmobile impacts the ground. The seat and suspension of your snowmobile have been designed to provide protection under normal riding conditions. Your snowmobile is not intended for this kind of use.
- Be courteous to oncoming traffic by dimming your headlights and reducing your speed.
- When traveling in a group of snowmobiles, don't tailgate (follow too closely). Leave enough distance between snowmobiles to provide ample stopping room and to provide protection from flying snow and debris. Allow even more distance when driving on slippery surfaces or when driving in darkness or other low visibility conditions. Be aware of any snowmobile traffic around your vehicle. Drive defensively to avoid accidents.
- Remove the key from the ignition when you leave the snowmobile unattended.

Operator Safety

Windchill/Temperature Charts

The following information is provided to help you determine when temperatures become dangerous for riding.

WINDCHILL CHART (°F)

Wind Speed in MPH	Actual Thermometer Reading (°F)																		
	40	35	30	25	20	15	10	5	0	-5	-10	-15	-20	-25	-30	-35	-40	-45	
	Equivalent Temperature (°F)																		
Calm	40	35	30	25	20	15	10	5	0	-5	-10	-15	-20	-25	-30	-35	-40	-45	
5	36	31	25	19	13	7	1	-5	-11	-16	-22	-28	-34	-40	-46	-52	-57	-63	
10	34	27	21	15	9	3	-4	-10	-16	-22	-28	-35	-41	-47	-53	-59	-66	-72	
15	32	25	19	13	6	0	-7	-13	-19	-26	-32	-39	-45	-51	-58	-64	-71	-77	
20	30	24	17	11	4	-2	-9	-15	-22	-29	-35	-42	-48	-55	-61	-68	-74	-81	
25	29	23	16	9	3	-4	-11	-17	-24	-31	-37	-44	-51	-58	-64	-71	-78	-84	
30	28	22	15	8	1	-5	-12	-19	-26	-33	-39	-46	-53	-60	-67	-73	-80	-87	
35	28	21	14	7	0	-7	-14	-21	-27	-34	-41	-48	-55	-62	-69	-76	-82	-89	
40	27	20	13	6	-1	-8	-15	-22	-29	-36	-43	-50	-57	-64	-71	-78	-84	-91	
45	26	19	12	5	-2	-9	-16	-23	-30	-37	-44	-51	-58	-65	-72	-79	-86	-93	
50	26	19	12	4	-3	-10	-17	-24	-31	-38	-45	-52	-60	-67	-74	-81	-88	-95	
55	25	18	11	4	-3	-11	-18	-25	-32	-39	-46	-54	-61	-68	-75	-82	-89	-97	
60	25	17	10	3	-4	-11	-19	-26	-33	-40	-48	-55	-62	-69	-76	-84	-91	-98	
Frostbite in >>										30 min.	10 min.	5 min.							

WINDCHILL CHART (°C)

Wind Speed in Km/h	Actual Thermometer Reading (°C)																		
	5	2	-1	-4	-7	-10	-13	-16	-19	-22	-25	-28	-31	-34	-37	-40	-43	-46	
	Equivalent Temperature (°C)																		
Calm	5	2	-1	-4	-7	-10	-13	-16	-19	-22	-25	-28	-31	-34	-37	-40	-43	-46	
8	3	0	-4	-7	-11	-14	-18	-22	-25	-29	-32	-36	-39	-43	-46	-50	-53	-57	
16	2	-2	-6	-10	-13	-17	-21	-24	-28	-32	-36	-39	-43	-47	-50	-54	-58	-62	
24	1	-3	-7	-11	-15	-19	-22	-26	-30	-34	-38	-42	-45	-49	-53	-57	-61	-65	
32	0	-4	-8	-12	-16	-20	-24	-28	-32	-36	-39	-43	-47	-51	-55	-59	-63	-67	
40	-1	-5	-9	-13	-17	-21	-25	-29	-33	-37	-41	-45	-49	-53	-57	-61	-65	-69	
48	-1	-5	-9	-13	-18	-22	-26	-30	-34	-38	-42	-46	-50	-54	-58	-62	-66	-70	
56	-2	-6	-10	-14	-18	-22	-26	-31	-35	-39	-43	-47	-51	-55	-59	-64	-68	-72	
64	-2	-6	-10	-15	-19	-23	-27	-31	-35	-40	-44	-48	-52	-56	-61	-65	-69	-73	
72	-2	-7	-11	-15	-19	-23	-28	-32	-36	-40	-45	-49	-53	-57	-61	-66	-70	-74	
80	-3	-7	-11	-15	-20	-24	-28	-33	-37	-41	-45	-50	-54	-58	-62	-67	-71	-75	
88	-3	-7	-12	-16	-20	-24	-29	-33	-37	-42	-46	-50	-55	-59	-63	-67	-72	-76	
96	-3	-8	-12	-16	-21	-25	-29	-34	-38	-42	-47	-51	-55	-60	-64	-68	-73	-77	
Frostbite in >>										30 min.	10 min.	5 min.							

SAFETY

Safety Labels and Locations

Warning labels have been placed on the snowmobile for your protection. Read and follow the instructions of the labels and other warnings on the snowmobile carefully. If any of the labels depicted in this manual differ from the labels on your snowmobile, always read and follow the instructions of the labels on the snowmobile.

If any label becomes illegible or comes off, contact your POLARIS dealer to purchase a replacement. Replacement *safety* labels are provided by POLARIS at no charge. The part number is printed on the label.

Pressure Cap Warning

This warning label is found on the pressure cap of applicable liquid cooled models:

WARNING

Do not open hot. Test or replace when changing coolant. Press down and turn to release cap. 13 PSI

7170063

Pressure Cap Warning



Track Warning

WARNING

Stay clear of track. Do not sit on seat back. Entanglement with the track or a fall from seat back may result in severe injury or death.

7175974

Track Warning

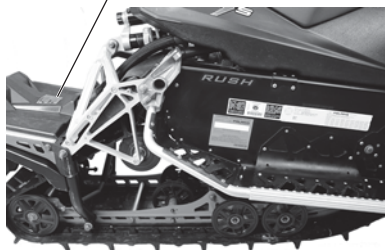

Safety Labels and Locations

No Passenger Warning

WARNING

This vehicle is designed for operator only. NO PASSENGER.

7181012

Fuel Recommendation Label

91+ Octane without Ethanol. For maximum performance see decal on left hand side panel for setting.

7181061

Fuel Recommendation Label

No Passenger Warning



Reverse Warning

Reverse Warning

WARNING

Reverse operation, even at low speeds, can cause loss of control resulting in serious injury or death. To avoid loss of control, always:

- Look behind before and while backing up.
- Avoid sharp turns.
- Shift to or from reverse only when stopped.
- Apply throttle slowly.

NOTE: For more information, see Owner's Manual.

If electric reverse:

- Machine stopped and engine at idle, push yellow button on LH control to reverse. Flashing light on dash indicates reverse operation.
- Push button again to return to forward.

7176779

SAFETY

Safety Labels and Locations

Operation Warning

WARNING

- To avoid serious injury or death, read and understand all warnings and the Owner's Manual before operation. If manual is missing, contact a POLARIS dealer for a replacement.
- This vehicle is capable of high speeds. Buried objects or uneven terrain can cause loss of control. Reduce speed and use extreme caution when operating in unfamiliar terrain.
- Excessive speed, especially at night or with limited visibility, can result in insufficient time for you to react to terrain changes, to avoid unexpected obstacles, or to stop safely.
- Never consume alcohol or drugs before or while operating this vehicle.
- In an emergency, push down the Auxiliary Shut-Off Switch, located on the top of the throttle control assembly, to stop the engine. Then pull the brake lever to stop.
- Always wear an approved helmet, eye protection, and adequate clothing while operating this vehicle.
- This vehicle is designed for adult use only. Check local laws for age requirements.
- When operating with a passenger (on approved models only) reduce speed and allow extra space for steering and stopping. A passenger reduces your ability to control the vehicle.
- When operating on hard-packed snow, ice, or when crossing roads, steering and braking ability are greatly reduced. Reduce speed and allow extra space to turn or stop.
- To maintain vehicle control on ice or hard-packed surfaces, you should have a proper balance of ski carbides to track studs. See Owner's Manual for proper use of traction products.
- Repeated stops from high speed may cause fading or sudden loss of braking ability.
- Parking brake may relax when used for long periods. Do not leave brake engaged for more than five minutes.
- Before starting engine, check throttle, brake, and steering for proper operation. Make sure hood and side panels are latched. Be seated and in position to control the vehicle.



Operation Warning

Oil injection system: Use unmixed fuel only. Check oil level when refueling.

7176779

Safety Labels and Locations Clutch Warning/Belt Removal

WARNING

Do not operate engine with hood or side panels open. Do not attempt adjustment with engine running. Do not operate engine with the clutch guard removed. Never run engine with drive belt removed. Never service clutches yourself - See your dealer.

Belt Removal - All Units

1. For electric reverse models, engine must be stopped in forward to allow clutch opening
2. Install L-wrench from fender into the open threaded hole in the driven clutch.
3. Turn the L-wrench clockwise to open the sheaves and replace the belt.
4. Return the L-wrench to the fender.

Note: See owners manual for sheave width adjustment procedure.

Clutch Warning/Belt Removal



7181093

FEATURES

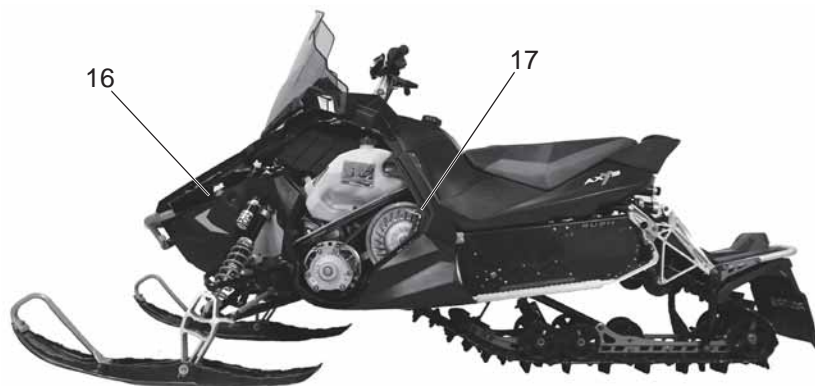
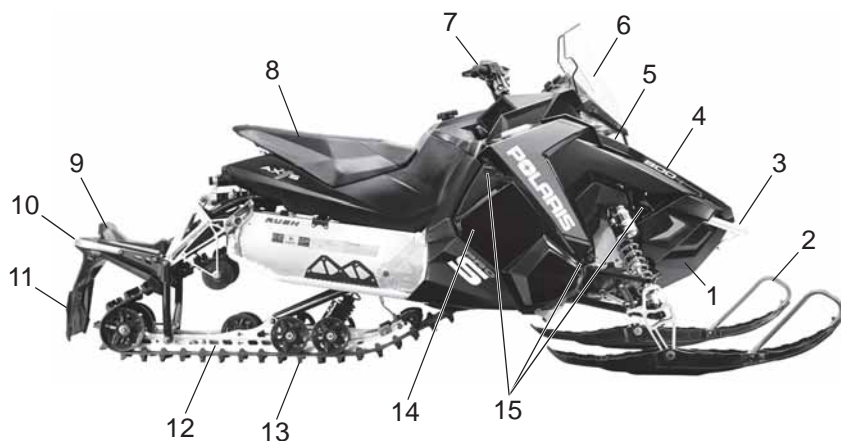

- | | |
|---------------------------|--|
| 1. Nosepan | 10. Rear Bumper |
| 2. Skis | 11. Snow Flap |
| 3. Front Bumper | 12. Suspension |
| 4. Hood | 13. Track |
| 5. Headlight | 14. Side Panel |
| 6. Windshield (accessory) | 15. Side Panel Fasteners |
| 7. Handlebar | 16. Tool Kit (Inside engine compartment) |
| 8. Operator Seat | 17. L-Wrench |
| 9. Taillight | |

FEATURES

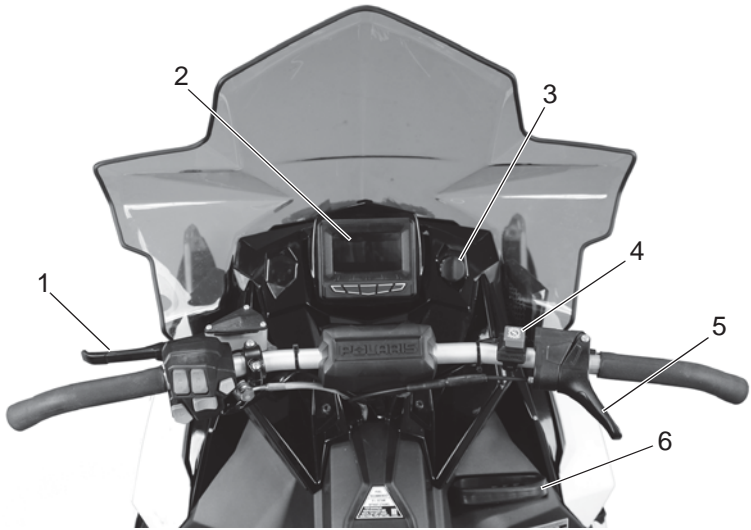

1. Brake Lever
2. Instrument Cluster
(Interactive Digital Display shown)
3. Ignition Switch
4. Engine Stop Switch
5. Throttle Control
6. Recoil Starter Handle
7. Parking Brake Lock
8. Handlebar Grip Warmer Switch
9. Thumbwarmer Switch
10. POLARIS Electronic Reverse (PERC) Button
11. Mode/Set Switch
12. Headlight Dimmer Switch

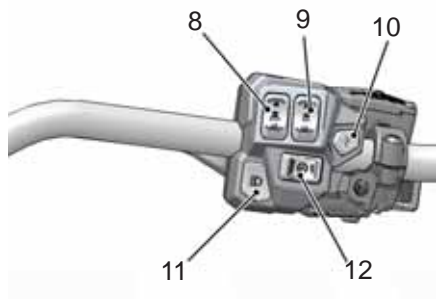
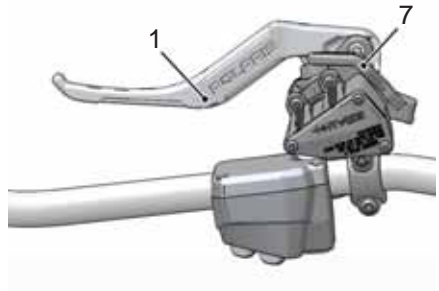

FEATURES

Adjustable Headlight

The headlight can be adjusted for vertical aim using the following procedure.

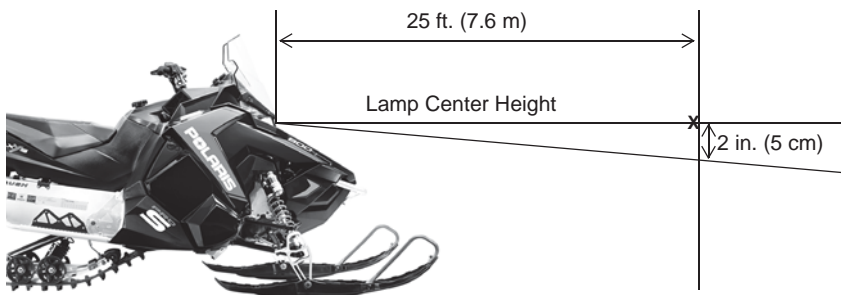

1. In a well-ventilated area, position the snowmobile on a level surface with the headlight approximately 25 feet (7.6 m) from a wall.
2. Place the rider or the approximate weight of the rider on the seat or tunnel floorboards.
3. Measure the distance from the floor to the center of the headlight and make a mark on the wall at the same height.
4. Start the engine. Move the headlight switch to high beam.
5. Observe the headlight aim on the wall. The most intense part of the headlight beam should be two inches (5 cm) below the mark on the wall.
6. If adjustment is necessary, access the headlight adjuster knob through the left side panel. Turn the adjuster knob clockwise to lower the beam. Turn the adjuster counter-clockwise to raise the beam.

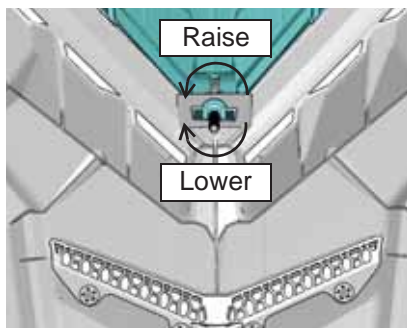

Heated Storage Compartment

The storage compartment on the top of the console is heated by engine compartment heat. This compartment can be used to warm gloves or defog goggles.

Heated Storage
(if equipped)



12-Volt Receptacle

If equipped, the 12-volt DC receptacle is located on the console next to the instrument cluster. If not equipped, the receptacle can be installed as an accessory.

The 12-volt receptacle is protected by a 2 AMP fuse.

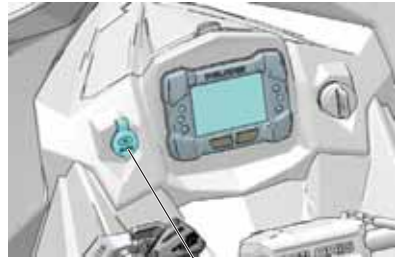

12-Volt Receptacle
(if equipped)

FEATURES

Saddlebags

Some snowmobiles are equipped with saddlebags. LOCK & RIDE saddlebags can be added as an accessory on other models. Please see your POLARIS dealer for more information.

Three (3) locking plungers secure each saddlebag to the rear cargo rack. To remove a saddlebag, open each plunger latch, then pull the bag away from the rack.

When reinstalling the saddlebags, always make sure the locking plungers are secured before operating.

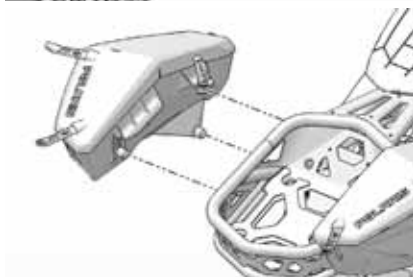
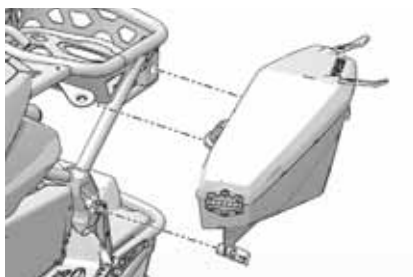

Fuel Type Selection

Whenever using ethanol, MTBE or other forms of oxygenated gasoline, the fuel type designation setting must be changed to “Eth” in the gauge. When using the recommended 91 non-ethanol gasoline, always select the “91-non” setting. *Whenever in doubt of your fuel purchase, use the “Eth” setting as a safeguard.*

Interactive Digital Display (IDD)

If your model is equipped with the interactive digital display (IDD), please see your IDD Owner’s Manual for fuel type selection procedures.

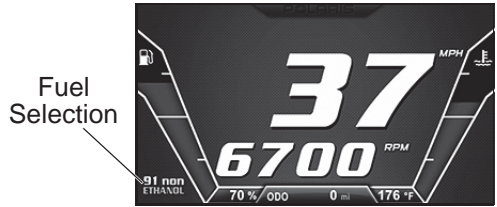

Standard Instrument Cluster

Use the following procedure to change the fuel type designation in the standard instrument cluster. *Refer to the fuel type selection label located inside the left side panel.*

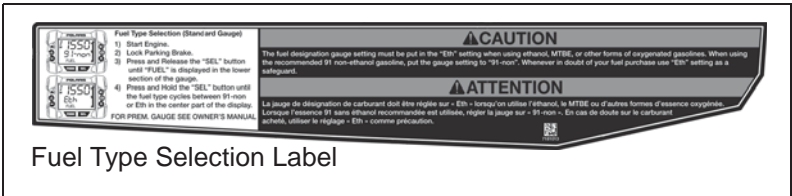

Fuel Type Selection Label

1. Start the engine. Lock the parking brake.
2. *Press and release* the SELECT button or SET switch until “FUEL” is displayed in the lower section of the gauge.
3. *Press and hold* the SELECT button or SET switch until the desired fuel type is displayed in the center of the screen.

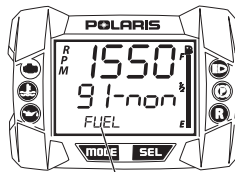

Step 2

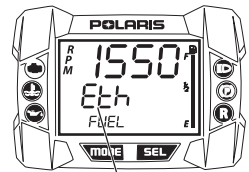

Step 3

FEATURES

Detonation Elimination Technology (DET)

The DET system prevents damage to the engine from detonation by entering an engine protection mode whenever the DET system is active.

When *excessive* detonation is detected, the check engine light will illuminate. You may notice decreased engine performance and RPM when the DET system is activated. In most cases this is temporary and no action is required. The engine will return to its normal performance automatically.



Standard Instrument Cluster



Interactive Digital Display (IDD)

If *severe* detonation occurs, the check engine light will begin to flash steadily.

- The standard gauge will display “DET”.
- The IDD will display “Detonation Detected - MAG (or PTO)”.

The engine will enter a *limp home* mode and engine speed will be limited to 6500 RPM. The engine will remain in this mode until it is shut down and restarted.

Check Engine Light	Indicates
Solid or Flickering	Excessive detonation detected
Steady Flashing	Severe detonation detected, RPM will be limited

FEATURES

Detonation Elimination Technology (DET)

The most likely causes of severe detonation are outlined in the troubleshooting table below.

DET Troubleshooting

Cause of DET Activation	Solution
Poor quality fuel	Replace with higher quality fuel
Incorrect ethanol/non-ethanol fuel type setting	Verify correct fuel type setting on gauge
Low fuel/no fuel in tank	Refuel with recommended fuel
Water in fuel	Replace with recommended fuel
Plugged fuel filter or tank pick-up sock	See your POLARIS dealer for service
Alcohol-based fuel additive used with Ethanol fuel	Do not add deicers or additives that contain any form of alcohol while using up to 10% ethanol fuel
Improper engine modifications	Do not modify the engine

FEATURES

Engine Overheat Indicators

Over-Temperature Indicator (Standard Cluster)

The over-temperature indicator on the standard instrument cluster will *illuminate* when the engine is overheating. Take action to cool the engine. See page 35.



The indicator will *flash* when engine temperature reaches critical levels. *Stop the engine immediately.*

Overheat Warning (IDD)

The engine temperature scale at the right side of the IDD screen changes to *RED* and the check engine temperature indicator at the top left of the screen illuminates when the engine is overheating. Take action to cool the engine. See page 35.

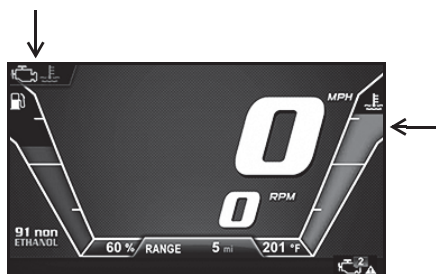

The indicator will *flash* when engine temperature reaches critical levels. *Stop the engine immediately.*

Please see your IDD Owner's Manual for more information.

Flashing Indicator

Flashing indicators indicate continued operation could result in serious engine damage. The engine management system will automatically reduce engine power and create a misfire condition. *Stop the engine immediately.* Allow the engine to cool down.

NOTE: If engine overheating seems to be caused by something other than poor cooling conditions, see your dealer for service.

Engine Overheat Indicators

Engine-Cooling Actions

If the engine is overheating, promptly take action to cool the engine.

- Drive in loose snow.
- View the coolant level. *Do not open the pressure cap while the engine is hot.* Add coolant if the level is low.
- Stop the engine and allow it to cool down.

NOTICE: If you must continue to operate while the indicator light is *illuminated*, drive slowly and stop the engine frequently to allow it to cool down.

Security System (Ignition Lock System)

Your snowmobile has an optional security function that can be activated by an authorized POLARIS dealer. If you have this feature activated, you can lock the ignition to prevent unauthorized use when leaving the snowmobile unattended. A locked system will limit engine speed to 3000 RPM, which prevents clutch engagement, and the snowmobile will not move when throttle is applied.

If you wish to use this system, see page 43 for security system activation and operating instructions (standard instrument cluster). If your model is equipped with the Interactive Digital Display (IDD), please see the IDD Owner's Manual provided with your snowmobile.

FEATURES

Standard Instrument Cluster



The instrument cluster contains indicator lights and the rider information center. The information center can be controlled by either the MODE and SELECT buttons on the instrument cluster or by the MODE/SET switch on the left handlebar.

NOTICE: Certain products will damage the lens and other plastic surfaces. Do not use alcohol to clean the instrument cluster. Immediately clean off any gasoline that splashes on the instrument cluster.

CAUTION! The speedometer may give wrong values at the existence of electromagnetic radiation ≥ 10 V/m.



Standard Instrument Cluster Indicators

Check Engine Indicator

This indicator appears if an EFI-related fault occurs. Do not operate the snowmobile if this warning appears. Serious engine damage could result. See your dealer. See page 92 for diagnostic code definitions.

Over-Temperature Indicator

This indicator illuminates to alert the operator that the engine is overheating. The operator should take action to cool the engine. If the indicator flashes, continued operation could result in serious engine damage. Stop the engine *immediately*.

Low Oil Indicator

The low oil indicator light may flicker at times due to oil movement in the bottle, but when the light comes on and remains on, add the recommended oil before further operation. See page 80.

High Beam Indicator

The high beam indicator illuminates when the lights are set to high beam.

Parking Brake Indicator

This indicator illuminates when the parking brake is engaged. It will also illuminate when the service brake is in use. See page 70.

Reverse Indicator

This indicator flashes when the snowmobile is in reverse. See page 85.

FEATURES

Standard Instrument Cluster

Rider Information Center

The rider information center is located in the instrument cluster. The center displays vehicle speed, engine speed, odometer, resettable trip meters (2), total engine hours of operation, fuel level, engine temperature and diagnostic display mode.

Setting changes must be made with the engine running or with the vehicle powered by an external DC power supply connector.

The information center is set to display standard units of measurement for distance and temperature. To change to metric units, see page 42.



Standard Instrument Cluster

Rider Information Center

1. **Information Display Area** - This area displays either engine speed or vehicle speed (whichever is not displayed in the speed display), engine temperature and maximum vehicle speed. To change the display, see page 40.
2. **Speed Display** - The speed display area displays either vehicle speed or engine speed. To change the display, see page 40.
3. **Fuel Gauge** - The segments of the fuel gauge show the level of fuel in the fuel tank. When the last segment clears, a low fuel warning is activated. All segments including the fuel icon will flash. Refuel immediately.
Tip: If the fuel icon fails to display, an open or short circuit has occurred in the fuel sensor circuit. See your dealer.
4. **Odometer/Engine Hour Display** - This area displays the odometer, Trip A, Trip B and engine hours. To change the display, see page 41.
5. **Battery Power** - This indicator illuminates when battery power is low.
6. **Playback Icon** - The playback function allows the rider to record and play back engine speed, vehicle speed and throttle position sensor information for up to three minutes. The playback icon flashes while recording. See page 41.

FEATURES

Standard Instrument Cluster

Rider Information Center

Speed Display Area

The speed display area displays either vehicle speed or engine speed. Vehicle speed is displayed in either miles per hour (MPH) or kilometers per hour (km/h). Engine speed is displayed in revolutions per minute (RPM).

1. To change which item displays, first make sure the information display area is set to display either engine speed or vehicle speed.
2. *Press and hold* the MODE button (on the instrument cluster) or the MODE switch (on the left handlebar) for three seconds.

Information Display Area

This area displays either engine speed or vehicle speed (whichever is not displayed in the speed display), engine temperature and maximum vehicle speed. To change the display, *press and release* the MODE button or the MODE switch until the desired item is displayed.

Standard Instrument Cluster

Rider Information Center

Odometer/Engine Hour Display Area

This area displays the odometer, Trip A meter, Trip B meter and engine hours meter.

The odometer displays the total distance traveled by the vehicle since manufacture. Each trip meter records the distance traveled by the vehicle on a trip if the meter is reset before each trip. The engine hour meter displays the total hours the engine has been in operation since manufacture.

To change the display, *press and release* the SELECT button or the SET switch until the desired item is displayed.

To reset a trip meter, *press and hold* the SELECT button or the SET switch until the meter resets to zero.

Playback Function

The playback function allows the rider to record and play back engine speed, vehicle speed and throttle position sensor information for up to three minutes.

1. To begin recording, simultaneously *press and hold* the MODE and SELECT buttons on the instrument cluster for three seconds. The playback indicator will flash while the instrument cluster is recording.
2. To play back the recorded data, stop the vehicle and wait for engine speed to drop below clutch engagement.
3. Simultaneously *press and release* the MODE and SELECT buttons on the instrument cluster.
4. Applying the throttle will clear the display and return the instrument cluster to normal operation.

FEATURES

Standard Instrument Cluster

Rider Information Center

Standard/Metric Display

The odometer and temperature displays can be viewed in either standard or metric units of measurement. Both displays change if units are changed. The new settings will remain until changed by the operator.

Change Method 1

1. *Press and release* the MODE button or MODE switch until engine temperature displays.
2. *Press and hold* the MODE button or MODE switch until the units change.

Change Method 2

1. *Press and release* the SELECT button or SET switch until the odometer displays.
2. *Press and hold* the SELECT button or SET switch until the units change.

Standard Instrument Cluster

Rider Information Center

Security System (Ignition Lock System)

This system is an optional feature and will not function until it has been activated by your authorized POLARIS dealer. If you have this feature activated, you can lock the ignition to prevent unauthorized use when leaving the snowmobile unattended. A locked system will limit engine speed to 3000 RPM, which prevents clutch engagement, and the snowmobile will not move when throttle is applied.

If you wish to use this feature, you must complete all four tasks on the following pages to have your system activated and to change the security code to one of your own choosing.

FEATURES

Standard Instrument Cluster

Rider Information Center

Security System (Ignition Lock System)

First Time Use of Your Security System

Perform all tasks in the order shown if you wish to activate and use the optional security system.

TASK 1: Activate the security system

See your authorized POLARIS dealer to have the optional security system feature activated in the electronic control unit (ECU).

TASK 2: Lock the System the First Time

1. Start the engine and lock the parking brake.
2. Press and hold the MODE and SEL buttons for 3 seconds, then release. SECURE OFF should be displayed. If not, repeat this step.
3. Wait until ENTER CODE displays, then press and release SEL to advance the digit. When "0" is displayed, press and release MODE to accept the digit. **TIP:** If the ENTER CODE screen exits due to inactivity, repeat step 2.
4. Press and release SEL to advance the second digit. When "0" is displayed, press and release MODE to accept the digit.
5. Press and release SEL to advance the third digit. When "0" is displayed, press and release MODE to accept the digit.
6. After accepting the third digit, view the display screen. SECURE ON displays if the system locks.

NOTE: The system is now *locked*.

7. You must now unlock the system. Proceed immediately to TASK 3.

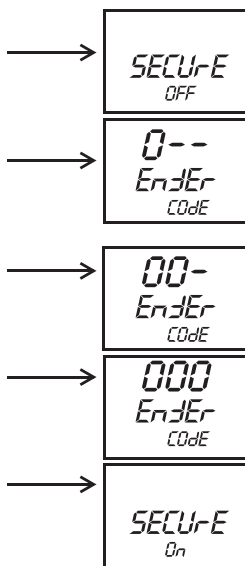

Standard Instrument Cluster Rider Information Center Security System (Ignition Lock System)

First Time Use of Your Security System

TASK 3: Unlock the System

- When the engine is running, the display will alternate between SECURE ON and ENTER CODE. Wait until ENTER CODE displays, then press and release SEL to advance the digit. When "0" is displayed, press and release MODE to accept the digit.
- Press and release SEL to advance the second digit. When "0" is displayed, press and release MODE to accept the digit.
- Press and release SEL to advance the third digit. When "0" is displayed, press and release MODE to accept the digit.
- After accepting the third digit, view the display screen. SECURE OFF displays if the system unlocks.

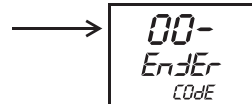
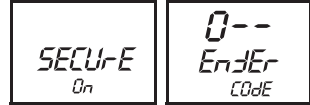

NOTE: The system is now *unlocked*.

- You must now enter a new security code. Proceed immediately to TASK 4.

TASK 4: Enter Your New Security Code

- Immediately after locking and unlocking the system, and while SECURE OFF is displayed, press and release the MODE button to bring up the ENTER CODE screen.
- When ENTER CODE displays, use the SEL and MODE buttons to select and accept each digit of a new personal security code.
- After accepting the third digit, view the display screen. The new code and CODE SET will display if the system accepted your new code. You will not see this display again.

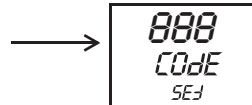

NOTE: Your new code is now set. The system is NOT locked.

- Record your new security code in a safe place for future reference.

Record your new personal security code here: _____

TIP: If you lose your personal security code, see your dealer to have the code reset to "000". Then perform TASK 2 through TASK 4 to change the code to one of your own choosing.

FEATURES

Standard Instrument Cluster

Rider Information Center

Security System (Ignition Lock System)

Locking the System With Your Personal Security Code

1. Start the engine and lock the parking brake.
2. Press and hold the MODE and SEL buttons for 3 seconds, then release. SECURE OFF should be displayed. If not, repeat this step.
3. Wait until ENTER CODE displays, then press and release SEL to advance the digit. When the first digit of your security code is displayed, press and release MODE to accept the digit.

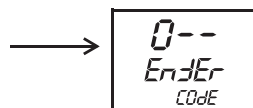

TIP: If the ENTER CODE screen exits due to inactivity, repeat step 2.

4. Continue to use SEL and MODE to select and accept the remaining two digits of the code.
5. After accepting the third digit, view the display screen. SECURE ON displays if the system locks. Engine speed is now limited and the snowmobile cannot be driven.

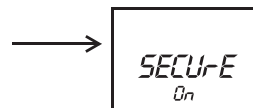

TIP: When the engine is running, the display will alternate between SECURE ON and ENTER CODE.

6. If BAD CODE displays, the screen will then return to the ENTER CODE screen. Repeat steps 3-5 to re-enter the security code.

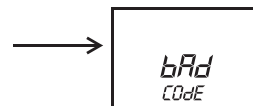

Standard Instrument Cluster

Rider Information Center

Security System (Ignition Lock System)

Unlocking the System With Your Personal Security Code

1. When the engine is running, the display will alternate between SECURE ON and ENTER CODE. Wait until ENTER CODE displays, then press and release SEL to advance the digit. When the first digit of your security code is displayed, press and release MODE to accept the digit.

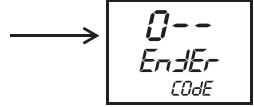

TIP: When the system is locked and engine temperature is above 120° F (49° C), the correct password must be entered within 60 seconds or the engine will shut down.

2. Continue to use SEL and MODE to select and accept the remaining two digits of the code.
3. After accepting the third digit, view the display screen. SECURE OFF displays if the system unlocks.
4. Re-enter your code if BAD CODE displays.



NOTE: The system is now *unlocked*.

FEATURES

Standard Instrument Cluster

Rider Information Center

Security System (Ignition Lock System)

Changing to a New Security Code

Any time you wish to change your current security code to a new code, perform TASK 2 through TASK 4 of the First Time Use of Your Security System procedure beginning on page 44. Instead of using the factory default code “000” in TASK 2 and TASK 3, use your current security code.

Security System Access Quick Reference

Now that you have become familiar with the procedure for locking and unlocking the system, use the chart below as a quick reference.

Security System Access Quick Reference Chart	
Action	Result
Start engine + Lock parking brake + Press and hold both MODE + SELECT (SEL)	Displays ENTER CODE (to lock the system)
Press SELECT (SEL)	Advances a digit on the ENTER CODE screen
Press MODE	Accepts a digit and displays the next digit position (if any remain) on the ENTER CODE screen or Opens ENTER CODE screen if MODE is pressed immediately after locking and unlocking the system (to change your security code)

Standard Instrument Cluster Rider Information Center Diagnostic Display Mode

The diagnostic display mode is for informational purposes only. Please see your POLARIS dealer for all major repairs.

The diagnostic mode is accessible only when the check engine warning indicator is illuminated *and* a diagnostic code is active.

Do not stop the engine if you want to view the active code (failure code). Active codes cannot be retrieved if power is interrupted to the instrument cluster. The codes will become inactive codes if power is interrupted. Inactive codes are stored in the history of the unit. Please see your POLARIS dealer to retrieve inactive codes.

Use the following procedure to view active codes.

1. Do not stop the engine.
2. With the brake engaged, press and release the **SELECT** button or **SET** switch to toggle to the diagnostic display mode. When a code is active, the diagnostic display mode will appear immediately following the engine hour display.

TIP: When the diagnostic mode is displayed, the check engine warning indicator will begin to flash.

3. A set of two numbers will appear in the display.
 - The 2-6 digit suspect parameter number (SPN) in the information display area indicates which component is generating the fault code.
 - The 1-2 digit failure mode indicator (FMI) number in the odometer area indicates the fault mode, such as open or short circuit.
4. More than one fault may be active. Press and hold the **MODE** button or **MODE** switch for two seconds to toggle to the next active code. Repeat until all codes are retrieved.
5. See page 92 for code definitions and failure descriptions.

FEATURES

Interactive Digital Display (IDD)



The Interactive Digital Display (IDD) provides the rider with:

- Speedometer
- Tachometer
- Odometer
- 2 Trip Meters
- Fuel Level Indicator
- Coolant Temperature
- Battery Voltage
- Fuel Type Selection
- Vehicle Security

The IDD also offers GPS mapping and Bluetooth® connectivity for compatible smartphones/devices. This feature will display text messages and missed phone calls on the display screen.

The IDD sub-menus and most display features are controlled by either the five button keypad on the IDD or by the MODE/SET switch on the left handlebar.



Please see your IDD Owner's Manual for more information.

NOTICE: Use a microfiber hand towel to clean the LCD screen. Certain products will damage the screen and other plastic surfaces. Do not use alcohol to clean the display screen. Immediately clean off any gasoline that splashes on the instrument cluster.

CAUTION! The speedometer may give wrong values at the existence of electromagnetic radiation ≥ 10 V/m.

Suspension Quick Set-Up Guide

Introduction

The front suspension and PRO-XC rear suspension on your AXYS snowmobile is incredibly easy to adjust. Just remember three simple steps:

1. Ride your snowmobile!
2. Adjust the *rear track shock spring* to tune *vehicle balance* (ski pressure and weight transfer).
3. Adjust *shock clickers* to tune *ride quality* (stiffer or softer ride).

Step 1: Ride your snowmobile!

Ride the snowmobile in various terrain to fully experience the existing suspension settings before making any adjustments.

Step 2: Adjust the rear spring to tune vehicle balance.

After riding the snowmobile, you should be able to determine if the snowmobile needs more “bite” or needs to be more “lite”. If the steering needs more “bite”, increase the rear track spring preload or decrease the front track spring preload.

If you prefer your snowmobile has lighter steering, decrease the rear track spring preload or increase the front track shock spring preload.

At the front of the snowmobile, if you prefer a taller ride height, increase the front suspension shock spring preload settings. Likewise, if you prefer your snowmobile has a lower ride height, you can decrease the front suspension shock spring preload settings.

Step 3: Adjust shock clickers for ride quality.

You can adjust the shock clickers to control bottoming and adjust ride comfort. Turning a clicker counter-clockwise decreases damping for a softer ride. Turning a clicker clockwise increases damping for a stiffer ride and less bottoming.



NOTICE: Always adjust the clicker at least one click below full stiff (full clockwise) or shock damage will occur.

Test ride the snowmobile and continue making spring and clicker adjustments until you achieve the perfect ride.

THE PERFECT FIT

Suspension Quick Set-Up Guide

Ride Experience Table

Ride Experience	Adjustment
Too "LITE" •Ski pressure is too light •Skis push 	Increase rear track shock spring preload OR Decrease front track shock spring preload
Too much "BITE" •Ski pressure is too heavy •Steering is heavy 	Decrease rear track shock spring preload OR Increase front track shock spring preload
Front Suspension (IFS Shocks): Too Stiff Too Soft	(IFS Shocks) Turn clickers 2 clicks SOFT Turn clickers 2 clicks HARD
Ride Comfort Under Feet (Front Track Shock): Too Stiff Too Soft	(Front Track Shock) Turn clicker 2 clicks SOFT Turn clicker 2 clicks HARD
Rear Suspension (Rear Track Shock): Too Stiff Too Soft	(Rear Track Shock) Turn clicker 2 clicks SOFT Turn clicker 2 clicks HARD

Shock Locations

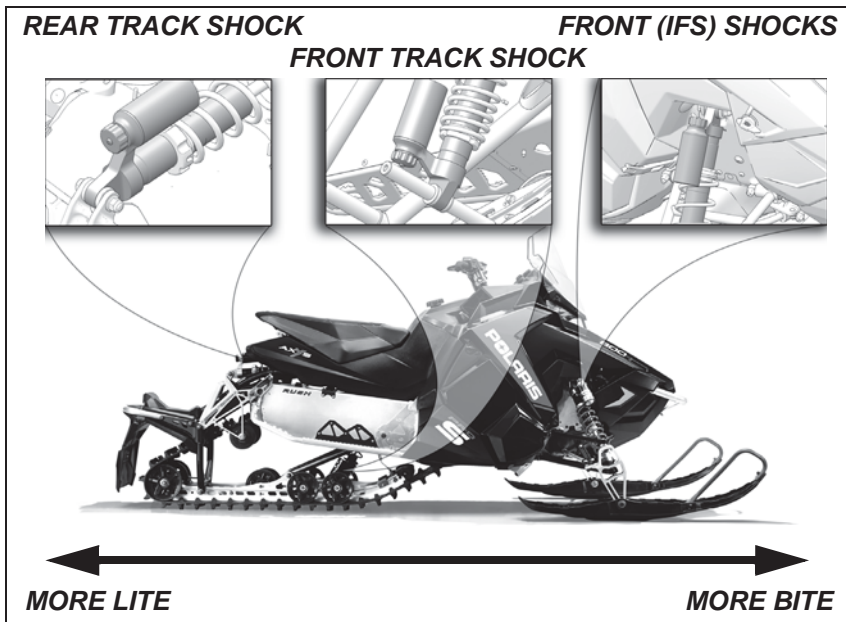

THE PERFECT FIT

Suspension Quick Set-Up Guide

Front Suspension (IFS) Factory Spring Settings

Spring Setting									
Model	Spring Rate		Preload (Factory Setting)		Preload (Minimum Setting)		Preload (Maximum Setting)		Spring Part Number
	lb/in	N/mm	in	cm	in	cm	in	cm	
RUSH PRO-S	80	14	2-1/2	6.4	2-1/2	6.4	3-1/2	8.9	7043732
RUSH PRO-X	100	17.5	4-1/2	11.4	4-1/2	11.4	4 3/4	12	7041576
SWITCHBACK PRO-S	80	14	2-1/2	6.4	2-1/2	6.4	3-1/2	8.9	7043732
SWITCHBACK PRO-X	100	17.5	4-1/2	11.4	4-1/2	11.4	4 3/4	12	7041576
SWITCHBACK ADVENTURE	80	14	2-1/2	6.4	2-1/2	6.4	3-1/2	8.9	7043732
SWITCHBACK ADVENTURE (International)	100	17.5	4-1/2	11.4	4-1/2	11.4	4 3/4	12	7041576

CAUTION! Never exceed the minimum/maximum spring preload settings. Always remove the vehicle weight from the spring prior to making adjustments.

Front Suspension (IFS) Factory Clicker Settings

Model	Clicker Setting (from full soft)
All PRO-S Models	3
All PRO-X Models	6
SWITCHBACK ADVENTURE	3
SWITCHBACK ADVENTURE (International)	6

THE PERFECT FIT

Suspension Quick Set-Up Guide

Front (IFS) Shock Adjustments

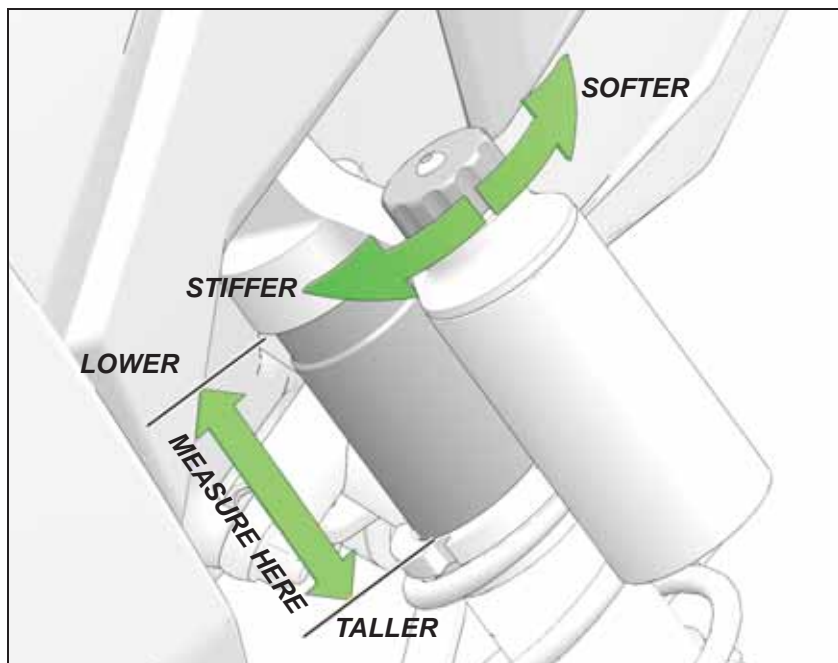

THE PERFECT FIT

Suspension Quick Set-Up Guide Front Track Shock Factory Spring Settings

Spring Setting									
Model	Spring Rate		Preload (Factory Setting)		Preload (Minimum Setting)		Preload (Maximum Setting)		Spring Part Number
	lb/in	N/mm	in	cm	in	cm	in	cm	
RUSH PRO-S	95-280	16.6-49	1-1/2	3.8	1-1/2	3.8	1.85	4.7	7043957
RUSH PRO-X	150	26	1	2.54	1	2.54	1-1/4	3.17	7043678
SWITCHBACK PRO-S	95-280	16.6-49	1-1/2	3.8	1-1/2	3.8	1.85	4.7	7043957
SWITCHBACK PRO-X	150	26	1	2.54	1	2.54	1-1/4	3.17	7043678
SWITCHBACK ADVENTURE	95-280	16.6-49	1-1/2	3.8	1-1/2	3.8	1.85	4.7	7043957
SWITCHBACK ADVENTURE (International)	150	26	1	2.54	1	2.54	1-1/4	3.17	7043678

CAUTION! Never exceed the minimum/maximum spring preload settings. Always remove the vehicle weight from the spring prior to making adjustments.

Front Track Shock Factory Clicker Settings

Model	Clicker Setting (from full soft)
All PRO-S Models	3
All PRO-X Models	6
SWITCHBACK ADVENTURE	3
SWITCHBACK ADVENTURE (International)	6

THE PERFECT FIT

Suspension Quick Set-Up Guide

Front Track Shock Adjustments

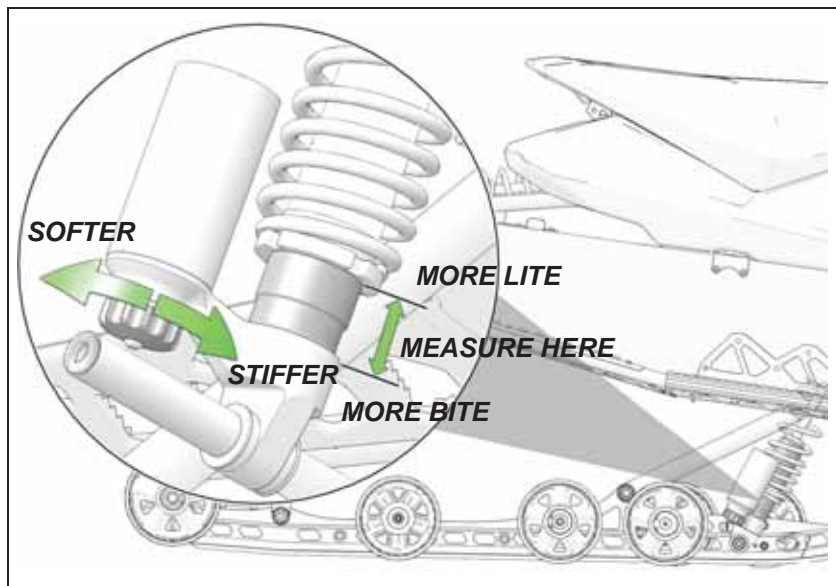

THE PERFECT FIT

Suspension Quick Set-Up Guide Rear Track Shock Factory Spring Settings

Spring Setting									
Model	Spring Rate		Preload (Factory Setting)		Preload (Minimum Setting)		Preload (Maximum Setting)		Spring Part Number
	lb/in	N/mm	in	cm	in	cm	in	cm	
RUSH PRO-S	120	21	2-3/4	7	2	5	3-1/2	8.9	7041575
RUSH PRO-X	150	26	1-1/2	3.8	1/2	1.2	2-1/2	6.4	7043160
SWITCHBACK PRO-S	120	21	2-3/4	7	2	5	3-1/2	8.9	7041575
SWITCHBACK PRO-X	150	26	1-1/2	3.8	1/2	1.2	2-1/2	6.4	7043160
SWITCHBACK ADVENTURE	120	21	2-3/4	7	2	5	3-1/2	8.9	7041575
SWITCHBACK ADVENTURE (International)	150	26	1-1/2	3.8	1/2	1.2	2-1/2	6.4	7043160
Optional HD Spring - RUSH / SWITCHBACK PRO-S ONLY (Rider Weight Range = 200-350 lbs (90-160 kg))									
PRO-S (Heavy)	150	26	1-1/2	3.8	1/2	1.2	2-1/2	6.4	7043160

CAUTION! Never exceed the minimum/maximum spring preload settings. Always remove the vehicle weight from the spring prior to making adjustments.

Rear Track Shock Factory Clicker Settings

Model	Clicker Setting (from full soft)
All PRO-S Models	3
All PRO-X Models	6
SWITCHBACK ADVENTURE	3
SWITCHBACK ADVENTURE (International)	6

THE PERFECT FIT

Suspension Quick Setup Guide

Rear Track Shock Adjustments

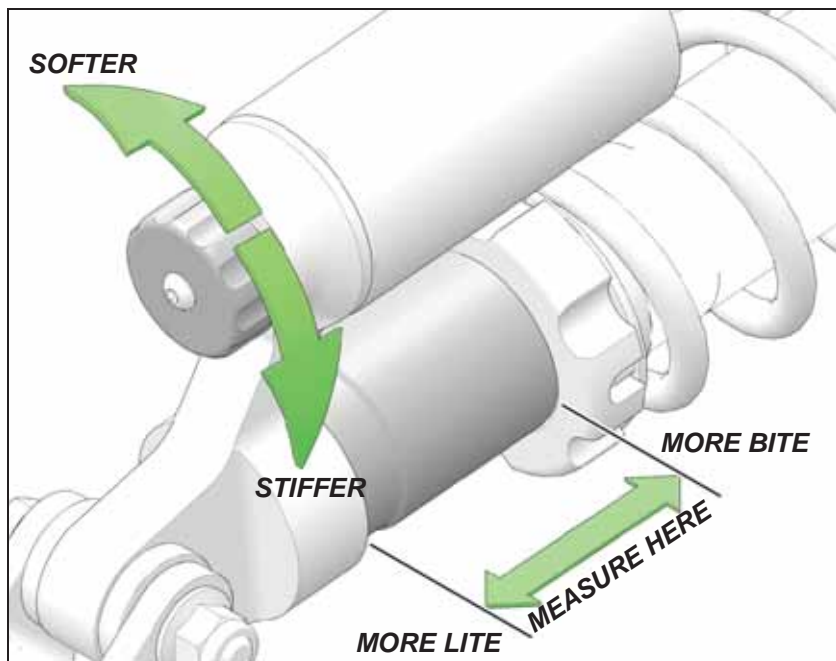

THE PERFECT FIT

Suspension Quick Setup Guide

Limiter Strap Adjustment

The front torque arm limiter strap is set at position #1.

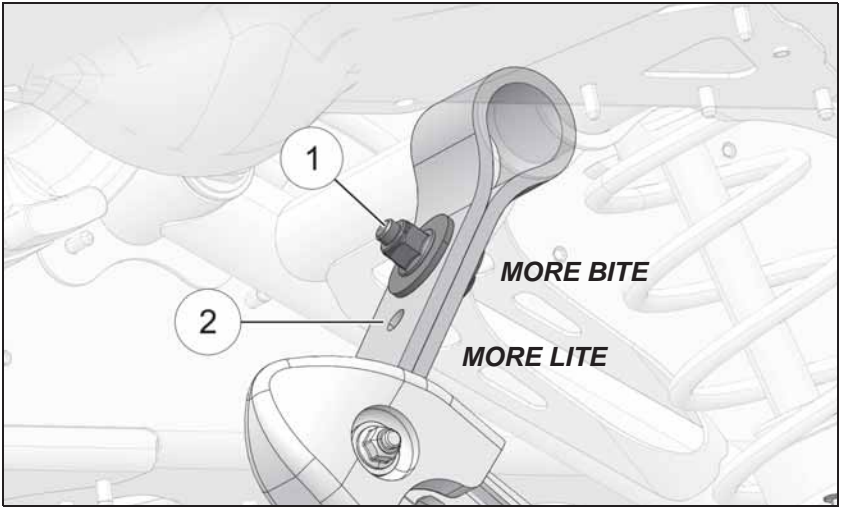

POLARIS recommends leaving the limiter strap length at position #1 to maintain the optimum ride characteristics of the snowmobile. Riders who desire less ski pressure and more weight transfer toward the rear of the snowmobile can lengthen the limiter strap by changing to position #2.

1. Loosen the lock nut.
2. Adjust the limiter strap.
3. Tighten the lock nut.

Torque: 17 ft-lbs (23 Nm).

THE PERFECT FIT

Handlebar Adjustments

Riser Angle

Riser angle can be adjusted to suit rider preference. Factory settings are shown below.

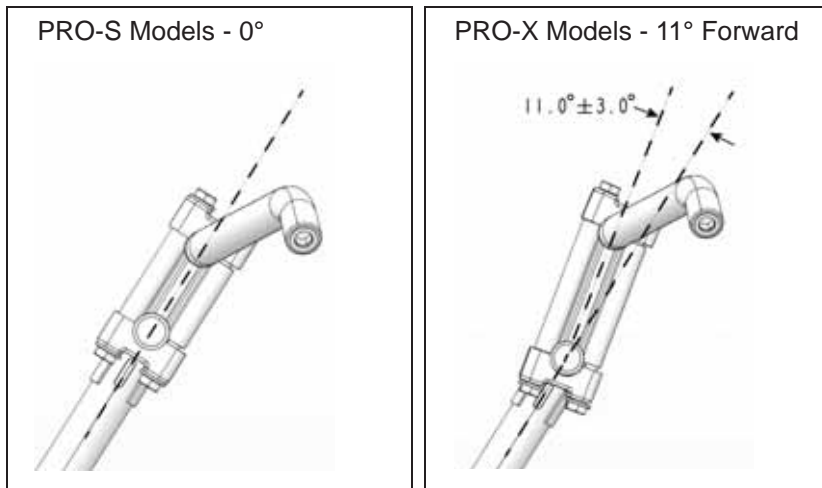

1. Loosen the four bolts on the bottom of the adjuster block. If necessary, pry the blocks apart with a screwdriver.
2. Adjust the riser forward or rearward to the desired position.
3. Tighten the bolts to 14.8 ft-lbs (20 Nm).

THE PERFECT FIT

Handlebar Adjustments

Handlebar Angle

Handlebar angle can be adjusted to suit rider preference. Factory settings are shown below.

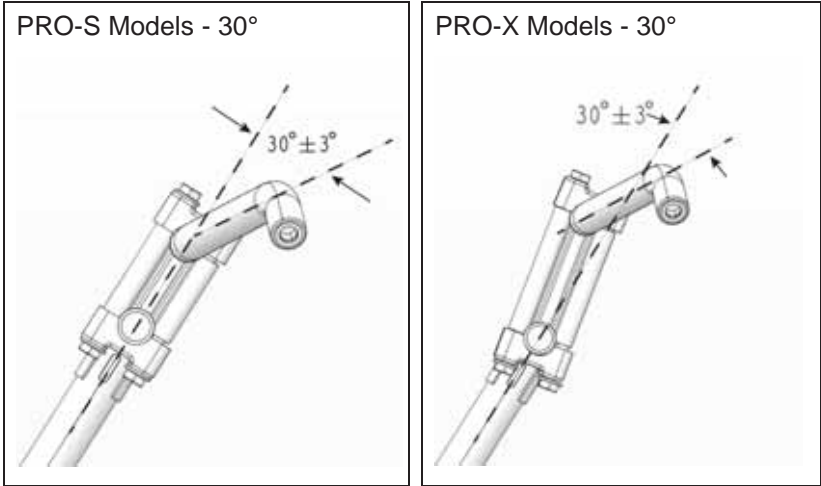

1. Loosen the four bolts on the top riser block.
2. Adjust the handlebar upward or downward to the desired angle. Be sure the handlebar, brake lever and throttle lever operate smoothly and do not hit the gas tank, windshield or any other part of the machine when turned fully to the left or right. If necessary, loosen the set screws for the left and right controls, rotate the controls *slightly*, then tighten the set screws to the proper torque. See page 62.

NOTICE: Do not stretch wires while adjusting the controls. Stretching the wires could damage the handwarmers.

3. Tighten the bolts.

Torque: 14.8 ft-lbs (20 Nm)

THE PERFECT FIT

Handlebar Component Fastener Torques

Shown with riser cover removed for clarity

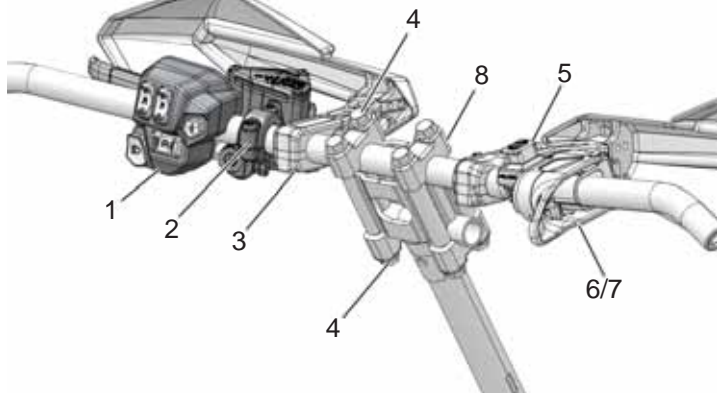

Component	Torque <i>Do not over-tighten</i>
1. Left Handlebar Control Block	20 in-lbs (2.3 Nm)
2. Brake Lever / Master Cylinder	70 in-lbs (7.9 Nm)
3. Hand Guard Mounts (if applicable)	Hand-Tight
4. Upper / Lower Riser Clamps	14.8 ft-lbs (20 Nm)
5. Auxiliary Engine Stop Switch Set Screw	12 in-lbs (1.4 Nm)
6. Throttle Lever Block Set Screw	27 in-lbs (3.1 Nm)
7. Throttle Lever Block Cover Screws	6 in-lbs (0.7 Nm)
8. Riser	-

THE PERFECT FIT

Handlebar Component Locations

Refer to the following illustration and measurements to position handlebar components at factory-specified locations.

Handlebar Component Alignment Measurements

1. .011 in. (3 mm)
2. 6.65 in. (169 mm)
3. 6.7 in. (170 mm)
4. 10 in. (254 mm)
5. .47 in. (12 mm)
6. .08 in. (2 mm)

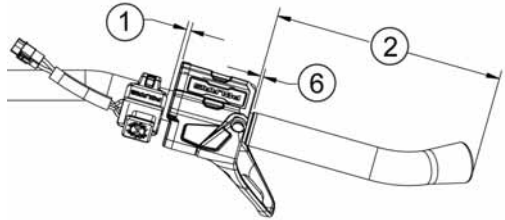
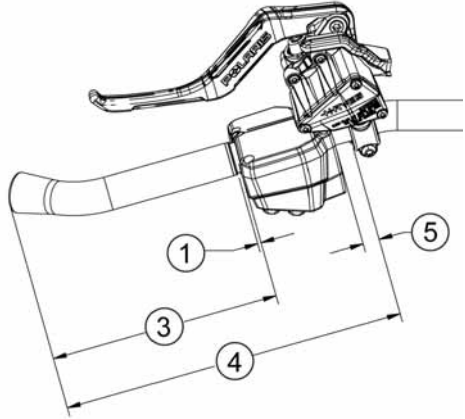

THE PERFECT FIT

Traction Products

Studs

The track is not warranted by POLARIS if studs have been installed. Track warranties are also void if track damage or failure results from the use of any non-POLARIS traction products. Use only POLARIS-approved traction products on your snowmobile.

If you choose to install studs, stud length must not exceed 1.325 inches (3.7 cm) for a factory-installed track.

See your dealer about installing studs and/or carbides.

NOTICE: Use of studs longer than the recommended length on snowmobiles equipped with center coolers will result in center cooler damage or damage to the tunnel.

Track studding will enhance braking control on hard-packed snow or ice, but extreme caution is still required on such surfaces. Steering ability may be reduced on hard-packed snow or ice.

When studded tracks are used, increased wear to the brake pads will result from increased braking and requires increased brake inspection intervals.

Installing studs can also cause the track to stretch more than a non-studded track. For this reason, POLARIS recommends inspecting track tension more often and setting the tension at the preferred measurement.

Always adhere to the manufacturer's stud maintenance procedures and stud nut torque specifications.

NOTICE: Aggressive studding patterns may require grinding protruding stud bolts flush to prevent idler wheel damage. Maintain track tension on studded tracks on the tight side of the specification to prevent heat exchanger damage. The center of the stud must be at least 1 1/8 inch (2.9 cm) from the outside edge of the track.

Before equipping your snowmobile with traction products, be aware of regulations pertaining to the use of traction products in your area of operation.

Traction Products

Carbide Skags

A skag is a replaceable bar attached to the underside of the ski to assist in turning the snowmobile and to prevent ski wear caused by contact with roads and other bare terrain. Use carbide skags with studded tracks to help maintain proper steering and control. See page 125.

Maintain a proper balance between the number of studs and the length of carbide on the skags (the more studs you use, the longer the carbide on the skags should be). See your dealer's track studding chart.

Wear Strips

Your snowmobile is equipped with integrated stud protection that will protect the cooling system and tunnel when using a maximum stud length of 1.325 inches (3.7 cm) for all tracks.

See your dealer's studding chart for recommended traction accessories.

PRE-RIDE INSPECTIONS

Pre-Ride Checklist

Inspect all items on the checklist for proper operation or condition before each use of the snowmobile. Procedures are outlined on the referenced pages.

Item	See Page
Drive Belt Condition	115
Steering System	71
Recoil Rope	71
Coolant Level	105
Chaincase Oil Level	98
Injection Oil Level	80
Parking Brake Lock/Brake Lever/Brake System	69, 70, 110
Auxiliary Shut-Off Switch (Engine Stop Switch)	72
Ignition Switch	72
Headlight/Taillight/Brake Light	72
Suspension Mounting Bolts	67
Skags (Wear Bars)	125
Ski Saddle and Spindle Bolts	67
Hood and Side Panel Fasteners	94-95
Throttle Lever / Throttle Release Switch	81, 82
Rear Wheel Idler Bolts	121
Tether Switch/Strap (if equipped)	72
Track Alignment/Condition	71, 122
Rail Slide Condition	128

PRE-RIDE INSPECTIONS

Pre-Ride Suspension Inspection

Loose nuts and bolts can reduce your snowmobile's reliability and cause needless repairs and down time. Before beginning any snowmobile trip, a visual inspection will uncover potential problems. Check the following items on a weekly basis or before any long trip.

Item	See Page
Check suspension mounting bolts for tightness.	See Dealer
Check rear idler wheel bolts for tightness.	121
Check rear idler adjusting bolt locknuts for tightness.	--
Check front torque arm limiter strap condition.	--
Check rail slide condition.	128
Check track tension.	120
Check ski runner/skag condition.	125
Check ski spindle bolts for tightness.	123
Check tie rod end nuts for tightness.	--

PRE-RIDE INSPECTIONS

Before Starting the Engine

Before starting the engine, always refer to all safety warnings pertaining to snowmobile operation. Never start the engine without checking all vehicle components to be sure of proper operation.

WARNING! Operating the vehicle with worn, damaged, or malfunctioning components could result in serious injury or death. Never start the engine without checking all vehicle components to be sure of proper operation.

Read and Understand Your Owner's Manual

Read the Owner's Manual completely and refer to it often. The manual is your guide to safe and enjoyable snowmobiling experience.

Throttle Lever

The throttle and brake are the primary controls of your snowmobile. Always make sure both are functioning properly.

Squeeze the throttle lever to make sure it compresses evenly and smoothly. When released, the lever should immediately return to the idle position without binding or hesitation. If the throttle does not function smoothly, or if you discover excessive lever freeplay, DO NOT start the engine. Have the throttle serviced immediately.

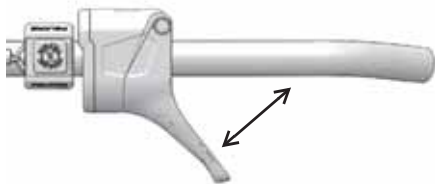

Throttle Release Switch

Test the throttle release switch system before operating the snowmobile. See page 81.

PRE-RIDE INSPECTIONS

Before Starting the Engine

Brakes

Always check the following items for proper operation before starting the engine.

Brake Lever Travel

NOTICE: Do not pump the brake lever when performing this procedure.

Squeeze the brake lever. It should move no closer to the handgrip than 1/2 inch (1.3 cm). A smaller distance indicates low brake fluid level or air in the hydraulic system. Refer to the brake bleeding information on page 112 or see your dealer for service.

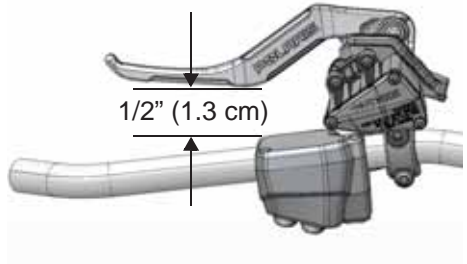

Lever Feel

If the brake lever feels “spongy” when squeezed, check the brake fluid level and condition. Add fluid as needed. See page 111.

WARNING! Continued use of “spongy” brakes may cause a complete loss of brakes, which could result in serious injury or death. Always have the brakes serviced at the first sign of sponginess.

Brake Fluid Level

Position the handlebars so the brake fluid reservoir is as close to level as possible.

View the fluid level through the reservoir (shaded in illustration). If the level is below the MIN (minimum) level specification, add POLARIS DOT 4 brake fluid. See page 111.

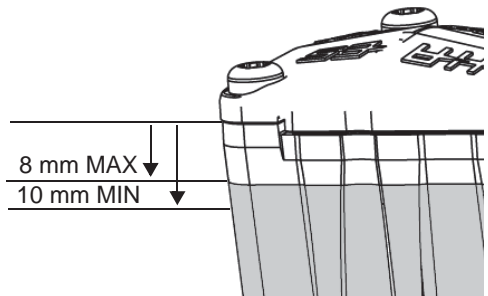

PRE-RIDE INSPECTIONS

Before Starting the Engine

Parking Brake Lever Lock

Use the parking brake lever lock only when you want the snowmobile to remain stationary; for example, when parked on an incline for a period of five minutes or less.

1. Brake Lever
2. Fluid Level Indicator
3. Master Cylinder Reservoir/Cover
4. Parking Brake Lever Lock

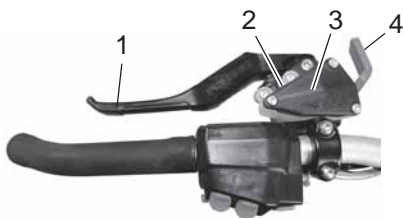

Lock Engagement

To engage the lock, squeeze the brake lever tightly and push forward on the lock. Hold the lock forward while releasing the brake lever.

TIP: If the brake lever is squeezed tightly enough, the lock will move freely into place. Do not force the lock or it may break.

The parking brake light will illuminate if the parking brake lever lock is set while the engine is running. It will also illuminate when the service brake is in use. If the parking brake light does not come on when the parking brake or service brake is in use, have it serviced by your dealer.

Lock Release

To release the lock, squeeze the brake lever tightly. The lock will return to the unlocked position.

WARNING! If the parking brake lever lock is partially or entirely engaged while riding, the brakes may overheat, resulting in brake damage. In extreme cases it could cause a fire, which could result in serious injury or death. Always ensure that the lever lock is completely disengaged before operating the snowmobile.

PRE-RIDE INSPECTIONS

Before Starting the Engine

Steering System

WARNING! Ice and snow build-up may interfere with the steering of your snowmobile, resulting in serious injury or death. Keep the underhood area free of snow and ice.

Before driving, manually turn the skis to the left and right to be sure ice and snow are not interfering with full left and right steering. If difficulty is encountered, remove ice and snow build-up that may be obstructing the steering linkage.

Track

Track damage or failure caused by operation on ice or poor lubrication conditions voids the track warranty.

WARNING! Operating the snowmobile with a damaged track increases the possibility of track failure, which could cause loss of control resulting in serious injury or death. Always inspect the track for damage before using the vehicle.

WARNING! Use of traction products such as studs increases the possibility of track damage and/or failure. Driving at high speeds for extended periods of time in marginal lubrication could severely damage track rods, break track edges, and cause other track damage. Examples of marginal lubrication would include frozen bodies of water without snow cover, icy trails and no-snow conditions.

Side Panel Fasteners

The side panels of the snowmobile protect the operator from moving parts. Never operate the engine with the side panels open or removed.

Recoil Rope

Inspect the recoil rope and handle for excessive wear, and make sure the knot securing the rope inside the handle is secure. If excessive wear is found, see your POLARIS dealer for replacement.



PRE-RIDE INSPECTIONS

Start the Engine and Check

Before starting the engine, always refer to all safety warnings pertaining to snowmobile operation. Never engage the starter when the engine is running. Never start the engine without checking all vehicle components to be sure of proper operation. See Before Starting the Engine beginning on page 68.

Auxiliary Engine Stop Switch

Check the auxiliary shut-off switch for proper operation. Push the switch down to stop the engine. Pull it up to allow restarting.

Ignition Key Switch

Make sure the engine stops when the ignition key switch is turned to OFF.

Tether Switch (if equipped)

If your snowmobile has a tether switch, remove the tether from the switch to make sure the engine stops immediately.

Lighting

Check the headlight (high and low beam), taillight and brake light. Make sure all lights work properly before operating.

Mirrors (if equipped)

Adjust the mirrors so they can be used to their full advantage.

Operating Area

Before driving away, check your surroundings. Be aware of obstacles and make sure bystanders are a safe distance from the snowmobile.

Ignition Switch

The ignition switch has three positions.

OFF	Vehicle / IDD power off
RUN	Vehicle / IDD power on
START	Activates starter motor (if equipped)

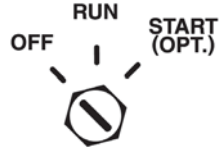

If equipped with electric start, turn the key to START to crank the engine. When the key is released, it automatically returns to the RUN position.

Snowmobiles equipped with electric start and/or IDD are equipped with a battery. If the key remains in the RUN position after using the engine stop switch to stop the engine, the IDD remains active. The IDD screen will turn off after several minutes of inactivity, but the IDD will continue to draw a small amount of current from the battery until the key is turned off. This feature is useful for accessing the IDD without starting the engine, but turn the key off when the IDD is not in use.

The IDD is not dependent on the battery while the engine is running, but the battery supplies a constant power source when the engine is turned off or when the engine is transitioning between forward and reverse operation. If the battery is not installed, the IDD reboots when the engine is started and when electronic reverse (PERC) is used.

Emergency Stopping

The following chart lists methods for stopping the snowmobile in the event of an emergency. See page 81 for more information about the engine stop switch and throttle release switch.

SYSTEM	WHAT IT DOES
Ignition Switch	Interrupts ignition circuit
Brake	Slows jackshaft
Auxiliary Engine Stop Switch	Interrupts ignition circuit
Throttle Release Switch	Enables Engine Control Unit (ECU) software RPM limit
Tether Switch (Option)	Interrupts ignition circuit

OPERATION

Starting the Engine

NOTICE: Engaging the starter when the engine is running WILL result in serious engine damage, especially if the snowmobile is in reverse. Never engage the starter when the engine is running.

1. Turn the key to the RUN position.
2. Pull the auxiliary engine stop switch up to the RUN position.
3. If equipped with electric start, turn the key to START to crank the engine. Release the key to the RUN position when the engine starts.
4. If not equipped with electric start, grasp the starter handle and pull slowly until the recoil engages; then pull abruptly to crank the engine.

TIP: Don't pull the starter rope to the fully extended position and don't allow it to snap back into the housing. Damage may result.

5. If the engine does not start after several attempts, slightly depress the throttle (no more than 1/4 inch (6 mm) open) while cranking the engine. When the engine starts, *immediately* release the throttle.

CAUTION! To avoid injury and/or engine damage, do not operate the electric starter or pull-rope starter while the engine is running.

NOTICE: Operating the vehicle immediately after cold starting could cause engine damage. Allow the engine to warm up for several minutes before operating the vehicle. If cold drive-away is attempted, the engine RPM may stumble slightly to protect the engine.

Restarting an Engine

If the rider stops the engine by pushing the engine stop switch down, restart the engine using the normal starting procedure. If the engine fails to start using the normal procedure:

1. Push the engine stop switch down to the OFF position.
2. Turn the key to the OFF position.
3. With both switches OFF, squeeze and hold the throttle in the wide open position.
4. Crank the engine several times to draw fresh air through the engine.
5. Release the throttle.
6. Restart the engine using the normal starting procedure.

Break-In Period

Engine Break-In

Always follow these recommended break-in procedures for new or rebuilt engines. The first tank of fuel is considered the break-in period for the engine.

Premix the first tank of fuel and fill the oil reservoir as outlined below. Oil added to the fuel and oil injection systems will provide the necessary engine lubrication.

Oil Recommendations	
First Tank of Fuel:	POLARIS VES 2-Cycle Oil
After Break-in:	POLARIS VES 2-Cycle Oil

See page 137 for the part numbers of POLARIS products.

Never mix brands of oil. Serious chemical reactions can cause injection system blockage, resulting in serious engine damage. Oils may also be incompatible and the result could be sludge formation, filter blockage, and reduced cold weather flow rates. All POLARIS oils are compatible with each other.

Initial Fuel Premix

Always premix fuel in 5-gallon (19-liter) increments in a separate fuel container. Never add oil directly to the fuel tank.

Fuel	VES 2-Cycle Oil	Ratio
Each 5 gal. (19 l)	16 oz. (473 ml)	40:1

OPERATION

Break-In Period

Engine Break-In

Excessive heat build-up during the first three hours of operation will damage close-fitted engine parts. Do not operate at full throttle or high speeds for extended periods during the first three hours of use. Vary the throttle openings and vehicle speeds to reduce friction on all close-fitting machined parts, allowing them to break in slowly without damage.

NOTICE: Use of any lubricants other than those recommended by POLARIS may cause serious engine damage. We recommend the use of POLARIS lubricants for your vehicle.

Drive with extra caution during the break-in period. Perform regular checks on fluid levels, lines, and all other important areas of the snowmobile.

Oil Injection System

Always check and fill the oil bottle when refueling. See page 80.

NOTICE: Serious engine damage can occur without the proper lubrication. Check the oil bottle level often during the first tank of fuel. If the oil level doesn't go down, contact your dealer immediately.

Drive Belt Break-In

The break-in period for a new drive belt is 30 miles (48 km). During this time, vary the throttle position under 50% and limit full throttle use.

Always take time to warm up the belt and driveline prior to operating the snowmobile. Free the track and skis from the ground before engaging throttle.

Track Warm-Up

WARNING! A loose track or flying debris could cause serious injury or death. Stand clear of the front of the snowmobile and the moving track. Never hold the snowmobile up or stand behind it while warming up the track. Do not use excessive throttle during warm-up or when the track is free-hanging. Use a stable rear support.

WARNING! Use of traction products such as studs will increase the possibility of track damage and/or failure. This could cause loss of control, resulting in serious injury or death. Always inspect for track damage before operating the snowmobile.

Follow these steps to ensure proper warm-up of the engine, drive train and track.

1. Never rotate a dry track. For best track performance, always lubricate the track with water or snow before rotating the track.
2. Use an appropriate stand to securely support the rear of the snowmobile at the rear bumper. The track should be about 4 inches (10 cm) off the ground.
3. Start the engine and allow it to warm up two to three minutes.
4. Depress the throttle abruptly and allow the track to rotate several revolutions.

TIP: It will take longer to warm up the track sufficiently during colder outdoor temperatures.

5. Release the throttle, apply the brakes, shut off the engine and lower the snowmobile to the ground.
6. Grasp the skis by their front loops and move them from side to side to loosen snow and ice.

Slide Rail and Track Cooling

NOTICE: Inadequate cooling and lubrication will lead to overheating of the slide rail and track, resulting in premature wear and failure. Reduce speeds and frequently drive into fresh snow to allow adequate cooling and polishing of the slide rail and track surfaces. Avoid operating on ice, hard-packed surfaces or roads.

OPERATION

Fuel

WARNING

Gasoline is highly flammable and explosive under certain conditions.

- Always exercise extreme caution whenever handling gasoline.
- Always refuel outdoors or in a well-ventilated area.
- Always turn off the engine before refueling.
- Do not overfill the tank. Do not fill the tank neck.
- Do not smoke or allow open flames or sparks in or near the area where refueling is performed or where gasoline is stored.
- If gasoline spills on your skin or clothing, immediately wash it off with soap and water and change clothing.
- Never start the engine or let it run in an enclosed area. Engine exhaust fumes are poisonous and can cause loss of consciousness or death in a short time.

WARNING

The engine exhaust from this product contains chemicals known to cause cancer, birth defects or other reproductive harm. Operate this vehicle only outdoors or in well-ventilated areas.

Fuel Recommendation

For peak performance, POLARIS recommends the use of 91 octane fuel or higher. Although 87 octane fuel is usable, some engine performance will be lost and fuel economy will decrease. Do not use lower than 87 octane fuel. *Do not use fuel containing more than 10% ethanol. Never use E85 fuel in your snowmobile.*

NOTICE: Operating with obstructed fuel systems will result in serious engine damage. Perform maintenance as recommended.

Prolonged exposure to petroleum based products may damage paint. Always protect painted surfaces when handling fuel.

Fuel System Deicers

If you use non-ethanol fuel (sometimes labeled “non-oxygenated”), POLARIS recommends the regular use of isopropyl-based fuel system deicer. Add one to two ounces per gallon (8-16 ml per liter) of gasoline to prevent damage resulting from fuel system icing. *Never use deicers or additives containing methanol.* POLARIS recommends the use of Carbon Clean. See page 137 for the part numbers of POLARIS products.

If you use fuel with up to 10% ethanol (sometimes labeled “oxygenated”) do not add deicers or additives that contain any form of alcohol.

OPERATION

Oil

Low Oil Level

Always maintain the oil level between the “ADD” mark and the bottle neck. Do not fill the bottle neck. See page 75 for oil recommendations.

1. *Immediately* stop the engine if the low oil indicator light comes on.
2. Open the left side panel. See page 94.
3. View the oil level in the oil bottle.
4. Add oil as needed before operating.

NOTICE: Operating the snowmobile without adequate engine lubrication can result in serious engine damage. Always check the oil level when refueling. Add oil as needed.

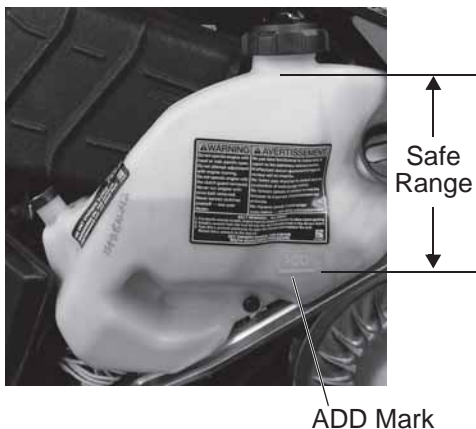

The oil bottle cap is vented to allow proper oil flow. See your POLARIS dealer for recommended replacement parts.

Auxiliary Engine Stop Switch

Push the auxiliary engine stop switch down to ground out the ignition and stop the engine quickly. Pull the switch up to the RUN position to allow restarting.

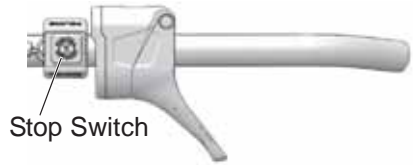

Throttle Release Switch

The throttle release switch is designed to stop the engine if all pressure is removed from the throttle lever and the throttle cable or throttle plates do not return to the normal closed position.

WARNING! Operating the snowmobile with a faulty throttle release switch can result in serious injury or death in the event of an accident. If the throttle release switch does not shut off the engine during a throttle system malfunction, immediately push down the auxiliary engine stop switch. Do not start the engine again until the malfunction has been corrected by your dealer.

Test the throttle release switch system daily before operation.

1. Sit on the seat.
2. Start the engine and allow it to idle.
3. Press and hold the lever pivot as shown.
4. While preventing the lever from pivoting, slightly push the throttle lever as shown. A properly functioning switch must shut down the engine.

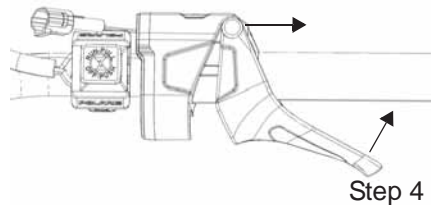
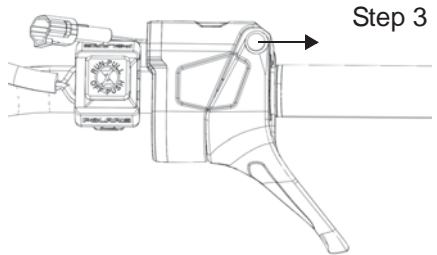

OPERATION

Throttle Lever

WARNING! An improperly functioning throttle lever may cause erratic snowmobile behavior and loss of control, which could result in serious injury or death. If the throttle lever does not work properly, **DO NOT** start the engine.

If the engine stops abruptly when the throttle lever is released:

1. Turn the ignition switch to OFF.
2. Visually inspect the throttle cable and throttle body to determine what caused the throttle release switch to activate.
3. Test the throttle lever by compressing and releasing it several times. The lever and cable must return to the idle position quickly and completely.
4. If the throttle lever operates properly, turn the ignition switch on and go through normal starting procedures.
5. If the engine doesn't start, take the snowmobile to an authorized POLARIS dealer for service.

Throttle Lever Freeplay Inspection

Throttle lever freeplay is the gap created between the throttle lever and throttle block, as you push the throttle lever, prior to the throttle cable opening the throttle body plates. Excessive freeplay in the throttle cable may cause the throttle release switch to activate, potentially stalling the engine or preventing the engine from starting.

To inspect throttle lever freeplay, follow these steps:

1. Stop the engine.
2. Slightly push the throttle lever until you feel the cable tension increase (throttle plates opening).
3. Insert the blade of a feeler gauge between the throttle lever and throttle block. The gap must be .009-.029 in. (0.25-0.76 mm).
4. Adjust freeplay if the gap does not meet specification. See page 83.

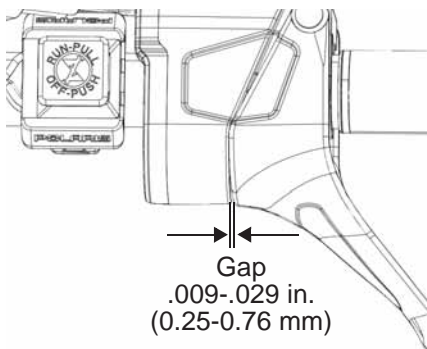

Throttle Lever

Throttle Lever Freeplay Adjustment

Adjust throttle lever freeplay using the in-line throttle cable adjuster.

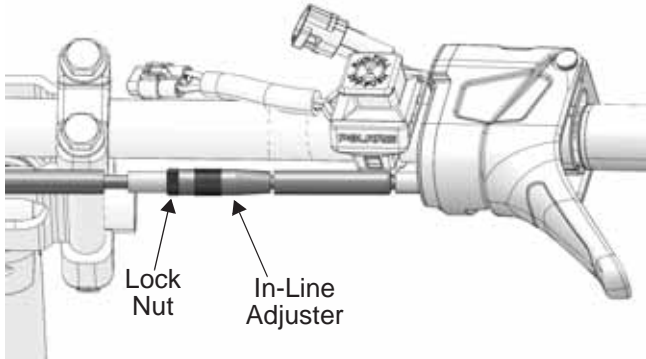

1. Locate the in-line adjuster on the throttle cable.
2. Loosen the lock nut.
3. Rotate the adjuster clockwise to DECREASE freeplay. Rotate the adjuster counter-clockwise to INCREASE freeplay.
4. When freeplay is adjusted to .009-.029 in. (0.25-0.76 mm), tighten the lock nut against the adjuster.
5. Start the engine and allow it to idle.
6. Turn the handlebar to the full left and full right positions. Verify that engine RPM does not increase as the handlebar is turned. If engine RPM increases, the throttle lever freeplay is too tight and must be readjusted.

WARNING! Do not operate the snowmobile if throttle cable freeplay is too tight.

OPERATION

POLARIS Electronic Reverse Control (PERC)

WARNING

Improper reverse operation, even at low speeds, may cause loss of control, resulting in serious injury or death. Damage will occur to the chaincase if shifting is attempted when the engine is operating above idle speed.

- Shift to or from reverse only when the snowmobile is stopped and when engine speed is at idle.
- Look behind the vehicle before and while backing.
- Avoid sharp turns.
- Apply throttle slowly.

Electronic reverse will activate only if the engine RPM is below 4000.

NOTICE: Engaging the starter when the engine is running WILL result in serious engine damage, especially if the snowmobile is in reverse. Never engage the starter when the engine is running.

POLARIS Electronic Reverse (PERC)

Engaging Reverse

1. Stop the snowmobile and leave the engine idling.
2. Make sure the area behind your vehicle is clear.
3. Push the yellow reverse button on the left-hand control for one second, then release. The engine will automatically reduce RPM and start a reverse rotation. A flashing reverse light on the instrument panel will indicate that the snowmobile is in reverse.
4. Apply the throttle slowly to make sure the snowmobile is in reverse. The maximum engine RPM will be 6000 when in reverse.

TIP: If the engine stops running, the snowmobile will be in forward gear when it's restarted.

Disengaging Reverse

1. Stop the snowmobile and leave the engine idling.

NOTICE: Engaging the starter when the engine is running WILL result in serious engine damage, especially if the snowmobile is in reverse. Never engage the starter when the engine is running.

2. Push the yellow reverse button for one second and release. The engine will slow and begin to rotate forward. The light on the instrument panel will shut off.
3. Apply the throttle slowly to make sure the snowmobile is in forward.

OPERATION

Daily Storage

At the end of each ride, park the snowmobile on a level surface and support it at the rear with an appropriate track stand. The track should be suspended approximately 4 inches (10 cm) off the ground.

Remove the key and cover the snowmobile.

Towing

For your safety, do not attempt to use a tow hitch until you've read the following warnings and understand the proper hitch functions.

WARNING! Objects towed with a rope have no braking power and can easily collide with the rear of the snowmobile or other objects, resulting in serious injury or death. DO NOT tow toboggans, sleds, saucers, or any type of vehicle with a rope. Only a stiff metal pole connecting the towed object and the tow hitch on the snowmobile should be used. If passengers are to be towed on a toboggan or sled, make sure the pole is at least four feet (1.2 meters) long to prevent any possibility of contact between the snowmobile's track and a person riding in the towed object.

WARNING! Braking distances increase when towing loads. Slow down to maintain control of the snowmobile.

If the snowmobile becomes inoperable and must be towed, and if it isn't possible to use a rigid tow bar, attach the tow rope to the ski spindles (not to the ski loops) to prevent damage to the steering components. Remove the drive belt before towing, and have someone ride on the towed snowmobile to operate the brake and steering when necessary.

NOTICE: Towing a disabled snowmobile with the drive belt in place can result in serious damage to the engine and drive system. Always remove the drive belt from a disabled snowmobile before towing.

Emission Control Information

Any qualified repair shop or qualified person may maintain, replace, or repair the emission control devices or systems on your snowmobile.

Emission Control Label

Your snowmobile is equipped at the time of sale with an emission control information (ECI) label and a factory-installed emissions information hangtag. These items are required by U.S. Environmental Protection Agency regulations. The ECI label is permanently affixed to either the right side of the tunnel or the engine recoil cover. The ECI label should not be removed, even after you purchase the snowmobile. You may remove the factory-installed emissions information hangtag, which is intended solely for your use in making a purchasing decision.

Emission Control Maintenance Requirements

Your snowmobile is certified to operate on gasoline with a minimum octane level of 87 (R+M)/2. If your snowmobile is equipped with a check engine light and it comes on, you must take your snowmobile to a qualified dealer for diagnostic service. Specifications and adjustments for engine tune-ups are located in the Service Manual, which is available to your qualified service technician. Reverse (if equipped) must not be engaged during engine tune-ups.

Owner's Responsibilities

Please read the Snowmobile Engine Emissions Limited Warranty, and read the maintenance section of your owner's manual. You are responsible for ensuring that the specified maintenance is performed. POLARIS recommends that you contact an authorized POLARIS dealer to perform any service that may be necessary.

Non-ionizing Radiation

This vehicle emits some electromagnetic energy. People with active or non-active implantable medical devices (such as heart monitoring or controlling devices) should review the limitations of their device and the applicable electromagnetic standards and directives that apply to this vehicle.

MAINTENANCE

POLARIS Recommended Maintenance Program

To ensure many trouble-free miles of snowmobiling enjoyment, follow recommended regular maintenance and perform service checks as outlined in this manual. Record maintenance and service in the Maintenance Log beginning on page 171.

The recommended maintenance schedule on your snowmobile calls for service and maintenance inspections at 150 miles (240 km), 500 miles (800 km) and 1000 miles (1600 km). These inspections should be performed by a qualified service technician. For continued optimum performance and component life, continue maintenance checks at 1000 mile (1600 km) intervals.

All necessary replacement parts and labor incurred, with the exception of authorized warranty repairs, become the responsibility of the registered owner. If, during the course of the warranty period, part failures occur as a result of owner neglect in performing recommended regular maintenance, the cost of repairs are the responsibility of the owner.

Personal safety is critical when attempting to service or make adjustments to your snowmobile. If you're not familiar with safe service or adjustment procedures and the use of tools, or if you don't feel comfortable performing these tasks yourself, contact an authorized POLARIS dealer for service.

NOTICE: Hot components can cause damage to plastic. Always make sure the exhaust system and engine have cooled before tipping the snowmobile on its side for service or inspection.

MAINTENANCE

Periodic Maintenance Interval Table

The following chart is a guide based on average riding conditions. You may need to increase frequency based on riding conditions. When inspection reveals the need for replacement parts, always use genuine POLARIS parts, available from your POLARIS dealer.

Item	See Page	Frequency				
		150 mi. (240 km)	500 mi. (800 km)	1000 mi. (1600 km)	2000 mi. (3200 km)	Pre-Season
CLUTCH						
Clutch Alignment Offset (without belt)	114		I	I	I	
Drive Belt Condition	115		I	I	I	I
Clutches	114		C	C	C	
Belt Tension	--		I	I	I	I
Clutch Sheaves	114		I	I	I	I
ENGINE/COOLING						
Engine Mounts	--		I	I	I	I
Recoil Rope	--		I	I	I	I
VES System (600 Engine Only)	--				C	
Coolant Level	105		I	I	R	I
Coolant Hose	--		I	I	I	I
Coolant Circulation	--		I	I	I	
Coolant Leaks	--		I	I	I	I
Spark Plugs	104		I	I	R	I
Exhaust Pipe	108				I	I
Exhaust Retaining Springs	108		I	I	I	I

I - Inspect (clean, adjust, tighten, lubricate, replace if necessary)

C - Clean R - Replace L - Lubricate

MAINTENANCE

Periodic Maintenance Interval Table

Item	See Page	Frequency				
		150 mi. (240 km)	500 mi. (800 km)	1000 mi. (1600 km)	2000 mi. (3200 km)	Pre-Season
BRAKES						
Hose Routing	--		I	I	I	I
Hose Condition	--		I	I	I	I
Fluid Leaks	--		I	I	I	I
Brake Pads	110		I	I	I	I
Brake Disc	--		I	I	I	I
Parking Brakes	70		I	I	I	I
Brake System	69 110					I
Brake Fluid	111				I	
FUEL MANAGEMENT						
Throttle Lever	82	I	I	I	I	I
Fuel Lines	101		I	I	I	I
Oil Lines				I	I	I
Air Box	--	I	I	I	I	I
ELECTRICAL						
Auxiliary Shut-Off Switch	72	I	I	I	I	I
Throttle Release Switch	81	I	I	I	I	I
Ignition Switch	--	I	I	I	I	I
Taillight	72	I	I	I	I	I
Brake Light	72	I	I	I	I	I
Headlight	72	I	I	I	I	I

I - Inspect (clean, adjust, tighten, lubricate, replace if necessary)

C - Clean R - Replace L - Lubricate

MAINTENANCE

Periodic Maintenance Interval Table

Item	See Page	Frequency				
		150 mi. (240 km)	500 mi. (800 km)	1000 mi. (1600 km)	2000 mi. (3200 km)	Pre-Season
CHASSIS						
Ski Toe Alignment	--		I	I	I	
Suspension Mounting Bolts	--	I	I	I	I	I
Bolt Torques		I	I			I
Steering Fasteners	--	I	I	I	I	C
Rear Suspension Fasteners	--	I	I	I	I	I
Suspension Shock Oil	--				R	
Rear Shock Threads	98					L
Skags (Wear Bars)	125	I	I	I	I	I
Ski Saddle/Spindle Bolts	--	I	I	I	I	I
Drive Chain Tension	109	I	I	I	I	I
Hood and Side Panel Fasteners	94	I	I	I	I	I
Rear Wheel Idler Bolts	121	I	I	I	I	I
Idler Bolt Jam Nut	121	I	I	I	I	I
Handlebar Centering	--					I
Tether Switch and Strap	72	I	I	I	I	I
Track Tension	120	I	I	I	I	I
Track Alignment	122	I	I	I	I	I
Front Limiter Strap	--	I	I	I	I	I
Rail Slide Condition	128					I
Chaincase Oil	98	I	R	I	R	I

I - Inspect (clean, adjust, tighten, lubricate, replace if necessary)

C - Clean R - Replace L - Lubricate

MAINTENANCE

Diagnostic Display Code Definitions

Open Load: There is a break in the wires that lead to the item listed in the chart (injector, fuel pump, etc.), or the item has failed.

Short-to-Ground: The wire is shorted to ground between the electronic control unit and the item listed in the chart.

Shorted Load: The wires leading to the item listed in the chart are shorted together, or the item has shorted internally.

Short-to-Battery: The wire leading from the item listed in the chart to the electronic control unit is shorted to a wire at battery voltage.

Diagnostic Codes			
Component	Condition	SPN	FMI
Throttle Position Sensor	Voltage Too High	51	3
	Voltage Too Low		4
	Abnormal Rate of Change		10
Vehicle Speed Sensor	Data Erratic, Intermittent or Missing	84	2
Intake Air Temperature Sensor	Voltage Too High	105	3
	Voltage Too Low		4
Barometric Pressure Sensor	Voltage Too High	108	3
	Voltage Too Low		4
Engine Temperature Sensor	Voltage Too High	110	3
	Voltage Too Low		4
	Temperature Too High		16
	Engine Overheat Shutdown		0
	Temperature Above Normal Range		15
Alternator Power Supply Potential (DC Chassis Voltage)	Voltage Too High	167	3
	Voltage Too Low		4
Exhaust Temperature Sensor	Voltage Too High	173	3
	Voltage Too Low		4
ECU Memory	Checksum/CRC Error	628	13
Injector 1 (MAG)	Driver Circuit Open/Grounded	651	5
	Driver Circuit Short to B+		3
Injector 2 (PTO)	Driver Circuit Open/Grounded	652	5
	Driver Circuit Short to B+		3
Knock Sensor 1	Voltage Too Low	731	4
Ignition Coil Primary Driver 1 (MAG)	Driver Circuit Open/Grounded	1268	5
Fuel Pump Driver Circuit	Driver Circuit Open/Grounded	1347	5

MAINTENANCE

Diagnostic Display Code Definitions

Diagnostic Codes			
Component	Condition	SPN	FMI
Knock Level Cylinder 1 (MAG)	Maximum Detonation Correction Limit Reached	1352	0
	Knock Above Critical Level		16
Knock Level Cylinder 2 (PTO)	Maximum Detonation Correction Limit Reached	1353	0
	Knock Above Critical Level		16
Sensor Supply Voltage 1 (TPS/TMAP Sensor Power)	Voltage Too Low	3509	4
Sensor Supply Voltage 2 (Ground Speed Sensor)	Voltage Too Low	3510	4
ECU Output Supply Voltage 2 (Injection Supply PWR)	Voltage Too High	3598	3
	Voltage Too Low		4
Throttle Release Signal	Voltage Too High	520194	3
	Voltage Too Low		4
	Throttle Stuck		7
Chassis Relay	Driver Circuit Open/Grounded	520208	5
	Driver Circuit Short to B+		3
Exhaust Valve Solenoid (600 Only)	Driver Circuit Grounded	520215	5
	Driver Circuit Short to B+		3
EV Actuator Driver (Controller) (800 H.O. Only)	Voltage Too High	520324	3
	Voltage Too Low		4
	Learn Failure		13
	Hardware Failure		12
	Commanded Pos. Not Achieved		7
	PWM Set Missing		2
	MAX Temperature Exceeded		520334
	Signal Out of Range - Valve Open	520325	31
	Signal Out of Range - Valve Mid	520326	31
	Signal Out of Range - Valve Closed	520327	31
	Short to Battery Voltage	520335	3
	Short to Ground		4
	Abnormal Transition		10
Electronic Oil Pump	Driver Circuit Open / Grounded	3589	4
	Driver Circuit Grounded		5
Oil Pump or Fuel Injector Settings not Programmed	Out of Calibration	520241	13

MAINTENANCE

Hood and Side Panels

The hood and side panels protect the operator from moving parts. Never operate a snowmobile with the side panels open or removed. Always ensure that the hood and side panels are installed and securely latched before starting the engine.

Side Panels (Opening/Removing)

To open a side panel, rotate the two 1/4-turn fasteners at the upper edges of the side panel. Release the strap at the lower edge of the side panel.

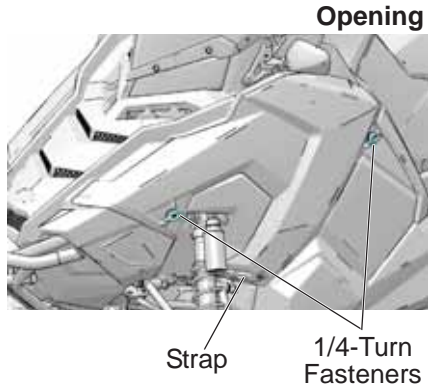

To remove a side panel, open the side panel, then pull the panel outward to release the tabs at the lower edge of the panel. Lift the side panel away from the snowmobile.

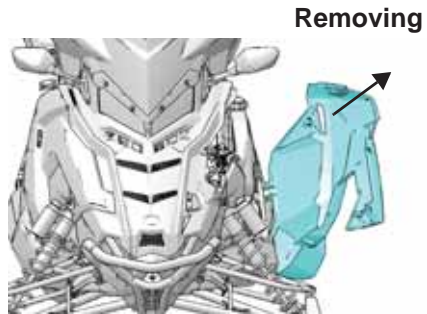

Hood Removal and Installation

1. Remove the side panels.
2. Rotate the 1/4-turn fasteners at the upper corners of the hood.
3. Disconnect the wire harness leading to the console electronics.
4. Remove the hood assembly.
5. To reinstall the hood, slide the nose clips into the nosepan.
6. Position the hood and align the 1/4-turn fasteners at the back of the hood. Secure the fasteners.
7. Reconnect the wire harness.
8. Reinstall the side panels.

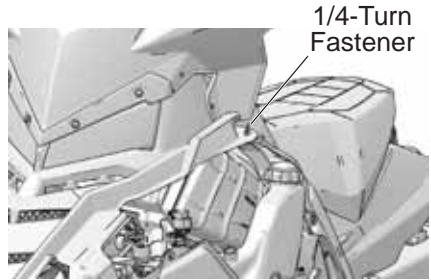

MAINTENANCE

Tools

An L-wrench and a tool kit (containing a spare belt, spark plug wrench and provisions for two spare spark plugs) are provided with the snowmobile. Open the left side panel to access the tools.

The L-wrench is used to open and close the driven clutch when working with the drive belt. The L-wrench, when properly engaged in the bracket, secures the fender to the console. To retrieve the L-wrench, rotate it counter-clockwise and slide it upward from the bracket. When it's not in use, return the L-wrench to the bracket and rotate it clockwise.



L-Wrench

The tool kit is stored in a container attached to the left tube of the front bumper. Use the following procedure to remove the spare belt container from the snowmobile.

1. Rotate the spark plug wrench counter-clockwise to release it from the bracket.
2. Pull the wrench upward to remove it.

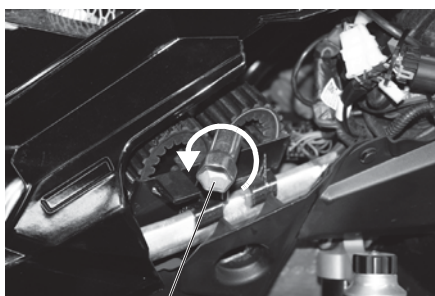

Spark Plug Wrench

NOTE: The wrench secures the container to the bumper.

3. Tilt the tool kit container until the bracket detaches from the bumper tube.



Step 3

Tools

4. Pull the container out of the compartment.
5. When reinstalling the drive belt into the container, fold the belt as shown. Verify that the belt loop at the rear of the container is positioned slightly higher than the front loop.



Step 4

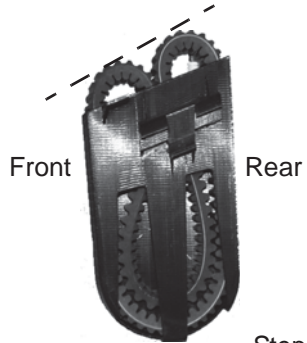

Step 5

6. Slide the container into the engine compartment at an angle.
7. Position the container bracket onto the bumper tube and rotate it downward.
8. Reinstall the spark plug wrench into the bracket and through the hole in the bumper tube.
9. Rotate the spark plug wrench clockwise until it locks into place.



Step 6

MAINTENANCE

Rear Shock Body

Lubricate rear shock body threads seasonally with a low-temperature synthetic grease.

Driveshaft Bearing

This model has sealed bearings that require no additional lubrication.

Chaincase Oil

Check and change the chaincase oil at the intervals outlined in the Periodic Maintenance Table beginning on page 88. Maintain the oil level at the top of the fill plug hole. POLARIS recommends the use of Synthetic Chaincase Lubricant. See page 137 for the part numbers of POLARIS products.

Oil Level Check

1. Position the snowmobile on a level surface.
2. Remove the fill plug.
3. Using a funnel, slowly add the recommended oil until the fluid begins to overflow.
4. Clean the area with a clean, dry shop towel.
5. Reinstall the fill plug.

Torque: 6-10 ft-lbs (8-13 Nm)



Threads



Fill Plug

Chaincase Oil Oil Change (Pump Method)

NOTE: This procedure requires the use of a commercially available hand pump oil extractor.

1. Elevate the front of the snowmobile using a floor jack or appropriate lift.
2. Remove the fill plug. Clean all metal shavings off the plug.
3. Insert the tube of a hand pump oil extractor into the fill hole. Direct the hose toward the bottom front area of the cover, away from the chain/sprocket.
4. Extract the oil from the chaincase.
5. Lower the snowmobile.
6. Using a funnel, slowly add the recommended oil until the fluid begins to overflow. Maximum fluid capacity is 10.5 oz. (310 ml).
7. Clean the area with a clean, dry shop towel.
8. Reinstall the fill plug.

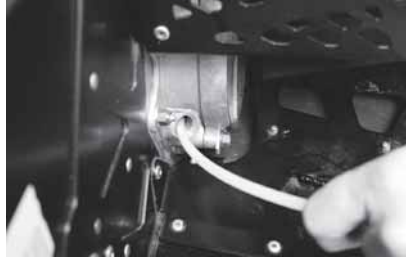

Torque: 6-10 ft-lbs (8-13 Nm).

MAINTENANCE

Chaincase Oil

Oil Change (Cover Drain Method)

1. Position the snowmobile on a level surface.
2. Remove the two screws securing the fender to the chaincase.
3. Remove the right side panel. If equipped with a battery, remove the battery and bracket.

NOTICE: When removing the battery, disconnect the BLACK (-) cable first, and then disconnect the RED (+) cable last.

4. Place a drain pan under the chaincase.
5. Loosen (do not remove) the chaincase cover screws.
6. Carefully pry the cover open.

NOTICE: DO NOT insert a screwdriver or pry bar between the cover and chaincase. Seal damage may occur.

7. Allow the oil to drain completely.
8. Tighten the cover screws.
Torque: 6-10 ft-lbs (8-13 Nm)
9. Remove the fill plug. Clean all metal shavings off the plug.

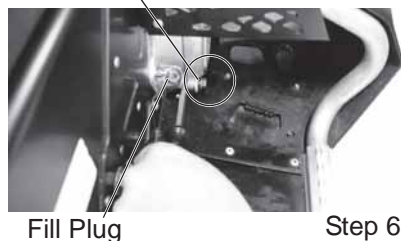
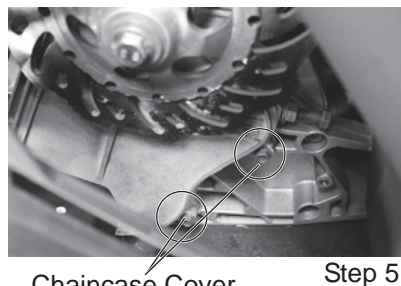
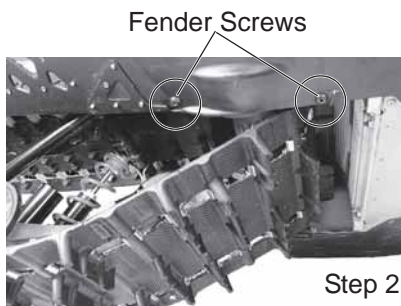

Chaincase Oil

Oil Change (Cover Drain Method)

10. Using a funnel, slowly add the recommended oil until the fluid begins to overflow. Maximum fluid capacity is 10.5 oz. (310 ml).
11. Clean the area with a clean, dry shop towel.
12. Reinstall the fill plug.
Torque: 6-10 ft-lbs (8-13 Nm)
13. Reinstall the screws securing the fender to the chaincase.

Fuel Filter / Fuel Lines

This snowmobile is not equipped with an in-line fuel filter. The fuel pump uses a sock-type pickup filter located within the fuel tank. This filter should only require maintenance if debris or foreign material enters the fuel tank. See your POLARIS dealer for service.

Contaminated or poor quality fuel may shorten the life of fuel system components and result in poor engine performance. Always store fuel in clean fuel containers. If low fuel pressure or reduced engine performance occurs between the recommended fuel filter service intervals, the filter may need replacement. Please see your dealer.

Inspect the fuel lines regularly for signs of deterioration or damage. Always check fuel line condition after periods of storage. Normal deterioration from weather and fuel compounds may occur. Replace worn or damaged fuel lines promptly.

NOTICE: Kinking the fuel lines or using a pliers or similar tools to remove fuel lines may cause damage to the lines. If a fuel line has been damaged or kinked, replace it promptly.

Fuel Pump

All fuel pump service must be performed by an authorized POLARIS dealer. Do not attempt to service the fuel pump.

MAINTENANCE

Intake Filters

The intake foam filters limit snow ingestion into the intake system. When operating in loose powder snow, check the foam filters periodically to remove any accumulation of snow.

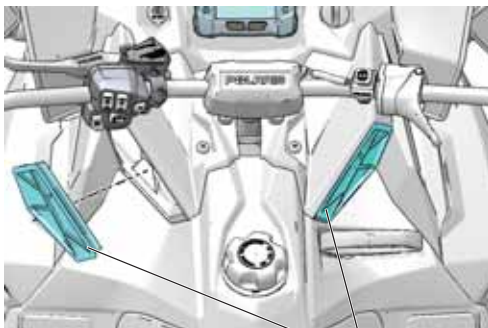

Foam Filters

Spark Plugs

Spark Plug Recommendations

A new engine can cause temporary spark plug fouling due to the preservative added during the assembly process. Avoid prolonged idle speeds, which cause plug fouling and carbonization.

Change the spark plugs at the intervals outlined in the Periodic Maintenance Table beginning on page 88.

- Use the recommended spark plugs with the proper gap. Refer to the specifications section beginning on page 142.
- Use only resistor-type spark plugs.
- Torque spark plugs to 18-22 ft-lbs (24-30 Nm).
- Always carry spare spark plugs.

NOTICE: Using non-recommended spark plugs can result in serious engine damage. A spark plug with a heat range too high will always cause engine damage if the engine is operated in conditions more severe than intended for that plug.

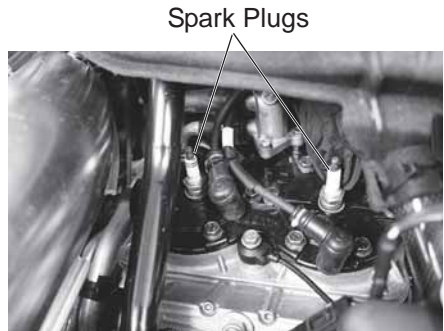

MAINTENANCE

Spark Plugs

Spark Plug Inspection

Spark plug condition is indicative of engine operation. The spark plug firing end condition should be read after the engine has been warmed up and the vehicle has been driven at higher speeds. Immediately check the spark plug for correct color.

CAUTION! A hot exhaust system and engine can cause burns. Wear protective gloves when removing a spark plug for inspection.

1. Remove the side panels and the hood.
2. Remove the spark plug cap.
3. Using the spark plug wrench provided in the tool kit, rotate the spark plug counter-clockwise to remove it.
4. Reverse the procedure for spark plug installation. Torque to specification.
5. Reinstall the spark plug cap. Verify and “audible” click is heard when installing the plug cap.

Spark Plug Condition

Normal Plug

The normal insulator tip is gray, tan or light brown. There will be few combustion deposits. The electrodes are not burned or eroded. This indicates the proper type and heat range for the engine and the service.

Wet Fouled Plug

The wet fouled insulator tip is black. A damp oil film covers the firing end. There may be a carbon layer over the entire nose. Generally, the electrodes are not worn. General causes of fouling are excessive oil or use of non-recommended injection oil.

Cooling System

Coolant

The coolant supplied in the system at the factory is a 50/50 mixture of ethylene-glycol and distilled water, which will provide adequate freeze protection under most conditions. If the vehicle will be stored or operated at extremely low temperatures, greater protection may be required. Please see your POLARIS dealer.

POLARIS recommends the use of POLARIS Antifreeze 50/50 Premix. This antifreeze is already premixed and ready to use. Do not dilute with water. See page 137 for the part numbers of POLARIS products.

Never add tap water to the cooling system. Minerals cause deposits and may react adversely with the metals in the engine and cooling system.

Coolant Level

The engine coolant level is controlled by the recovery system. The recovery system components are:

- Coolant bottle/overflow tank
- Pressure cap
- Connecting hoses

Always maintain the coolant level at or slightly above the FULL COLD mark on the coolant bottle (when the engine is cold).

1. Stop the engine.
2. Open the right side panel.
3. View the coolant level in the coolant bottle.
4. Add coolant as needed.

NOTICE: Operating the snowmobile with insufficient coolant will result in overheating and serious engine damage. Always maintain the coolant level as recommended.



FULL
COLD
Mark

MAINTENANCE

Cooling System

Flushing the Cooling System

To ensure that the coolant maintains its ability to protect the engine, drain the system completely every five (5) years and add a fresh mixture of antifreeze and distilled water. This service must be performed when the engine is cold. Ask your POLARIS dealer to check the coolant when he performs the fall tune-up on your snowmobile.

Bleeding the Cooling System

CAUTION! Steam and hot liquids will cause burns to your skin. Never bleed the cooling system or remove the pressure cap when the engine is warm or hot.

Use of a non-standard pressure cap will not allow the recovery system to function properly. If the pressure cap needs replacement, contact your dealer for the correct part.

NOTICE: Severe engine damage may occur if the cooling system becomes restricted or plugged or contains trapped air pockets.

Perform this procedure in a well-ventilated area. Use the recommended coolant. See page 105.

1. Open the side panels and remove the hood.
2. Close the side panels.

WARNING! Never operate a snowmobile with the side panels open or removed.

3. Position the snowmobile with the right ski and control arms elevated at a 45-degree angle.
4. Fill the coolant bottle to the COLD FILL mark.
5. Using an 8 mm wrench, loosen the air bleed screw located on the top of the coolant outlet elbow. Use a shop towel to catch any coolant that leaks from the bleeder. Tighten the screw after a steady stream of coolant flows from the bleeder.



Bleed Screw

Cooling System

Bleeding the Cooling System

6. Fill the coolant bottle to the COLD FILL mark.
7. Install the coolant bottle cap to the first lock. Do not tighten to the fully seated position.
8. Lock the parking brake.
9. Start the engine and allow it to run at a fast idle for several minutes, until the heaters are warm to the touch. Loosen the bleed screw occasionally to purge any trapped air.
10. When all heater extrusions are warm to the touch, stop the engine.
11. Allow the engine and cooling system to cool. Secure the bleed screw.
12. Fill the coolant bottle to the COLD FILL mark. Reinstall the bottle cap securely.
13. Carefully lower the front end of the snowmobile.
14. Open the side panels and reinstall the hood. Close the side panels.

MAINTENANCE

Exhaust System

Check the exhaust system for wear or damage at approximately 2,000 miles (3200 km). Always allow the engine and exhaust system to cool completely before inspecting.

CAUTION! Hot exhaust system parts can cause burns. Allow adequate time for the exhaust system to cool. Never perform this procedure with the engine running.

1. Open the side panels and remove the hood.
2. Inspect the muffler and pipes for cracks or damage.
3. Check for weak or missing retaining springs or damper/support grommets.
4. Check for loose clamps on the pipe covers.
5. Reinstall the hood and side panels.



Springs

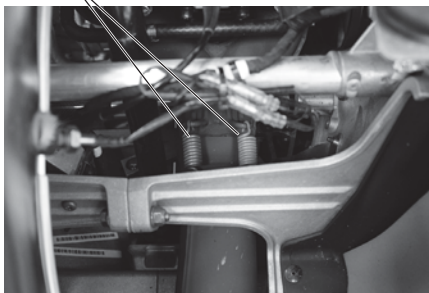

Drive Chain Tension

Check drive chain tension at the intervals outlined in the Periodic Maintenance Table beginning on page 88. Check again before each long trip.

CAUTION! Hot exhaust system parts can cause burns. Allow adequate time for the exhaust system to cool. Never perform this procedure with the engine running.

1. Remove the side panels.
2. Rotate the driven clutch counter-clockwise to move all chain slack to the tensioner side.
3. Lock the parking brake.
4. Loosen the adjuster bolt jam nut.
5. Finger-tighten the adjuster bolt until it can no longer be adjusted by hand, then back off 1/4 turn.
6. Tighten the jam nut while holding the adjuster bolt.
7. Reinstall the side panels.

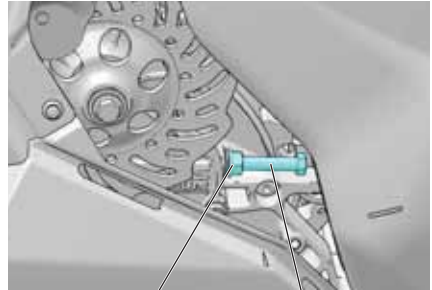

Jam Nut

Adjuster Bolt

Torque: 21 ft-lbs (28 Nm)

MAINTENANCE

Brakes

Hydraulic Brake Inspection

Inspect brake lever travel before each use of the snowmobile. See page 69.

Brake pads must be replaced when the brake pad material becomes thinner than the backing plate (approximately 1/16 inch or 1.5 mm). A kit is available for replacing brake pads. Please see your dealer.

WARNING! Brake failure during operation can result in serious injury or death. Properly functioning brakes are vital to your safety. Be sure the brake pads do not drag on the disc and that brake lever travel is not excessive. Always replace brake pads when the brake pad material becomes thinner than the backing plate (approximately 1/16 inch or 1.5 mm).

CAUTION! Hot exhaust system parts can cause burns. Allow adequate time for the exhaust system to cool. Never perform this procedure with the engine running.

Excessive Lever Travel

Hydraulic brakes are self-adjusting, but if excessive brake pad clearance develops, bring the snowmobile to an authorized POLARIS dealer for inspection and adjustment.

Brake Components

1. Brake Caliper
2. Brake Disc
3. Brake Pad Material - Replace when thickness is less than 1/16 inch (1.5 mm).

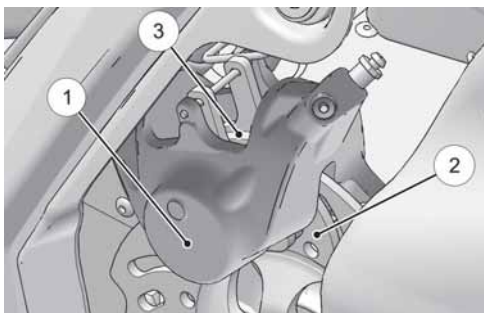

Brakes

Brake Fluid

Replace brake fluid at least every two years with POLARIS DOT 4 high temperature brake fluid. See page 137 for the part numbers of POLARIS products.

WARNING! After opening a bottle of brake fluid, always discard any unused portion. Never store or use a partial bottle. Brake fluid is hygroscopic, meaning it rapidly absorbs moisture from the air. The moisture causes the boiling temperature of the brake fluid to drop, which can lead to early brake fade and the possibility of accident or serious injury.

WARNING! Keep the master cylinder cover free of dirt and debris. The vent slits allow for diaphragm movement, and if they become plugged, movement of brake fluid below the diaphragm may be restricted, altering brake function.

NOTICE: Brake fluid will damage labels, paint and some plastics. Always wipe up spills immediately.

Brake Fluid Level

Position the handlebars so the brake fluid reservoir is as close to level as possible. View the fluid level through the reservoir (shaded in illustration). If the level is below the MIN (minimum) level specification, add POLARIS DOT 4 brake fluid.

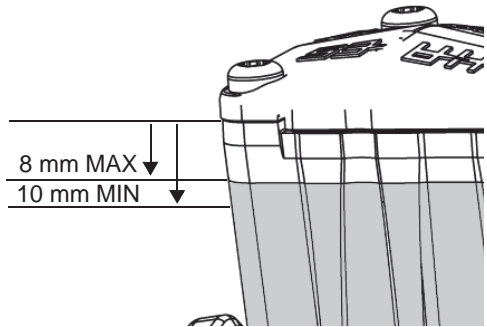

Adding Brake Fluid

CAUTION! Do not allow dirt or water to enter the brake reservoir.

1. Remove the reservoir cover and diaphragm.
2. Add the recommended brake fluid to the MAX level.
3. Reinstall the diaphragm.
4. Reinstall the cover and screws.

Torque: 11-13 in-lbs (1.2-1.4 Nm)

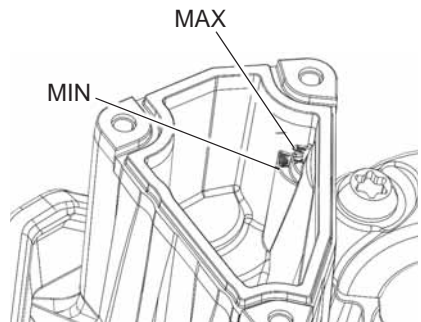

MAINTENANCE

Brakes

Bleeding the Hydraulic Brake System

Air in the hydraulic brake system will cause spongy brake lever action. Bleed the system before operating the snowmobile.

WARNING! Operating the vehicle with a spongy brake lever can result in loss of brakes, which could cause an accident and lead to serious injury or death. Never operate the vehicle with a spongy-feeling brake lever.

CAUTION! Hot exhaust system parts can cause burns. Allow adequate time for the exhaust system to cool. Never perform this procedure with the engine running.

During the bleeding procedure, keep the brake handle as level as possible. The reservoir must be in this position to minimize the possibility of air entering the system through the reservoir vent.

1. Remove the brake master cylinder reservoir cover and gasket.
2. Fill the master cylinder reservoir to between the MIN and MAX marks or 1/4-5/16 inch (.6-.8 cm) below the lip of the reservoir opening. Reinstall the gasket and cover.
3. Slip a rubber tube over the ball of the bleeder valve and direct the flow of fluid into an approved container.
4. Squeeze the brake lever a full stroke. Then unscrew the bleeder valve 3/4-turn to release air.
5. Close the bleeder valve and release the brake lever.
6. Repeat steps 4 and 5 until fluid flows from the bleeder valve in a solid stream free of air bubbles.

WARNING! Overfilling the master cylinder leaves no room for fluid expansion and may cause the brakes to lock, resulting in serious injury or death. Always add brake fluid to the fill line as recommended.

7. After bleeding is complete, refill the reservoir to the proper level. See page 111.
8. Reinstall the gasket and cover.

Lights

The headlight and taillight assemblies feature LED elements and are not serviceable. If an LED fails to illuminate in either the headlight or taillight, the entire assembly must be replaced. Please see your POLARIS dealer.

Headlight



Taillight

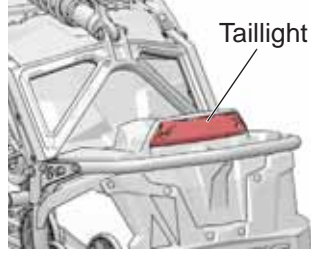

MAINTENANCE

Clutch System

Periodically inspect clutch sheaves for damage, wear or belt residue. To maintain optimum performance, clean with non-oil based cleaners such as isopropyl alcohol.

WARNING! If you become aware of higher than normal clutch engagement or an unusual vibration or shift pattern, see your dealer immediately. Do not operate the snowmobile until repairs have been made.

All clutch maintenance and repairs must be performed by an authorized POLARIS dealer. Any unauthorized modifications to clutches, such as adding or removing weights, will void the warranty.

NOTICE: The bushings in the weights and rollers of POLARIS clutches are made of a material that may be damaged if lubricated. Do not lubricate clutch bushings.

Clutch Alignment Offset

Clutch alignment offset is important for maintaining optimum performance. See your dealer for service and adjustments. A special tool is required to check for proper alignment.



Clutch System

Drive Belt Condition

Periodically check the condition and tension of the drive belt. Inspect the belt for signs of excessive wear: frayed edges, missing cogs, cracks and excessive looseness. Replace the belt if any of these conditions exist. See Drive Belt Troubleshooting on page 162.

Always carry a spare drive belt. Store the spare belt in the belt holder as shown. When placing the belt in the holder, orientate the belt to match the profile of the hood.

For improved drive-away during extremely cold temperatures, remove the belt and warm it to room temperature. Reinstall it before starting the snowmobile.



MAINTENANCE

Clutch System

Drive Belt Deflection

Measure belt deflection with both clutches at rest and in their full neutral position.

Place a straight edge (1) on the belt and apply downward pressure while measuring at point 2. This measurement should be 1 1/4 inches (3.2 cm).

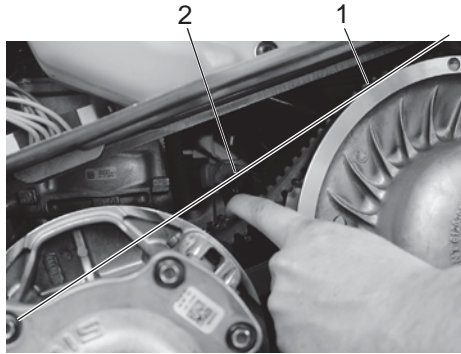

Drive Belt Deflection Adjustment

1. Loosen the 11 mm jam nut on the belt width adjuster.
2. Using a 3 mm Allen wrench, turn the set screw inward (clockwise) to increase the distance between the sheaves or outward (counter-clockwise) to decrease the distance.
3. Tighten the jam nut.

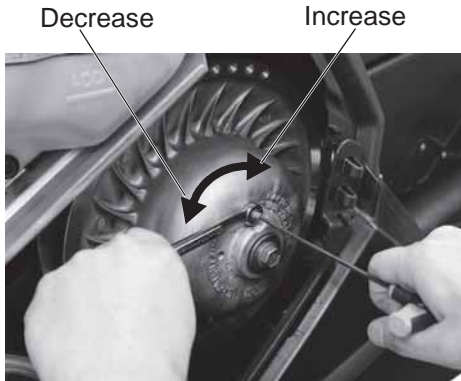

Clutch System Drive Belt Removal

NOTICE: Do not attempt to remove the drive belt after operating in reverse. The snowmobile must be stopped after forward motion to prevent damage to components during belt removal. Rotate the driven clutch counter-clockwise 1/4 turn by hand to ensure forward engagement before attempting to remove the belt.

1. Stop the engine after operating in a forward motion.
2. Turn the ignition key off. Wait for the engine to come to a complete stop.
3. Lock the parking brake.
4. Remove the left side panel.
5. Rotate the driven clutch counter-clockwise 1/4 turn by hand to ensure forward engagement.
6. Retrieve the L-wrench. See page 96. Install the wrench into the open threaded hole in the outer sheave of the clutch.
7. Turn the wrench clockwise until the sheaves open far enough to remove the belt.
8. Firmly grasp the belt midway between the clutches and pull upward and rearward to remove it.



Step 7



Step 8

MAINTENANCE

Clutch System

Drive Belt Installation

1. Verify the driven clutch sheaves are open. If they are not, install the L-wrench and open the sheaves.

NOTE: When installing the belt, verify POLARIS or the part number can be read from the outside of the snowmobile.

2. Drop the drive belt over the drive clutch and pull back the slack. The belt cord line should be flush with, or slightly above, the outer circumference of the driven clutch sheaves.

3. Hold the belt down between the sheaves and roll the bottom portion over the outer clutch sheave. Work the belt to the outer edge of the sheave.

4. Turn the L-wrench counter-clockwise to tighten the sheaves. Work the belt around the clutches as you remove the L-wrench.

Doing so will set the belt in “low gear”.

5. Reinstall the wrench to the wrench bracket to secure the fender to the console.

6. Reinstall the side panel.

7. Break in the new belt. See page 76.



Step 4

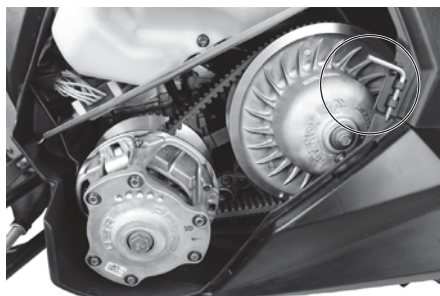

Step 5

Track Maintenance

Track Inspection

WARNING! Broken track rods can cause a rotating track to come off the snowmobile, which could cause serious injury or death. Never operate with a damaged track. Never rotate a damaged track under power.

1. Using a hoist, safely lift and support the rear of the snowmobile off the ground.
2. Rotate the track by hand to check for damage.
3. Carefully examine the track along the entire length of each rod. Bend the track to check for breakage.
4. Replace the track if any rod damage is found.



Track Lubrication

The slide rail needs snow for lubrication. Excessive wear indicates insufficient lubrication. A new rail slide can cause faster heat build-up in limited lubrication, resulting in excessive wear.

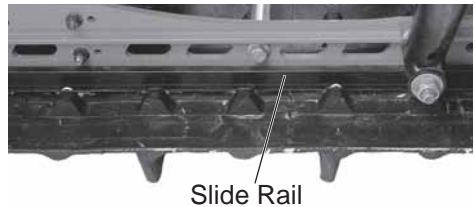

WARNING! Operating with insufficient lubrication between the rail slide and track guide clips can cause track failure, loss of vehicle control and loss of braking ability, which can result in serious injury or death. Avoid operating for extended periods on ice and other surfaces that have little or no snow for lubrication.

If excessive rail slide wear occurs due to poor snow conditions, additional wheel kits may be available. See your dealer for more information.

Track damage or failure caused by operation on ice or under other poor lubrication conditions will void the track warranty.

MAINTENANCE

Track Maintenance

WARNING! Moving parts can cut and crush body parts. When performing the checks and adjustments recommended on the following pages, stay clear of all moving parts. Never perform track measurement or adjustments with the engine running.

Track Tension

Track adjustment is critical for proper handling. Always maintain correct tension and alignment.

TRACK TENSION DATA CHART			
Suspension	Slack Measurement (Preferred - Maximum)	Weight	Measurement Location
RUSH 120	1 - 1-1/4 in. (2.54 - 3.175 cm)	10 lbs. (4.54 kg)	16 inches (40 cm) ahead of rear idler shaft
SWITCHBACK 137			

NOTE: If the track is studded, POLARIS recommends maintaining one (1) inch (2.54 cm) track tension setting at all times.

1. Verify the track is warmed up and limber. Stop the engine.

NOTICE: Do not use the rear bumper to lift the rear of the snowmobile for track adjustments.

2. Lift the rear of the snowmobile by the chassis (seat support, x-brace or running boards) until the track is slightly above the ground. Safely support the rear of the snowmobile in this position.
3. Place the recommended weight or downward pressure on the track at the specified distance (see chart) ahead of the center of the rear idler wheel.
4. Measure at the point where the weight is hanging.

Track Maintenance

Track Tension

5. Check for specified slack between the wear surface of the track clip and the plastic slider. Refer to the Track Tension Data Chart on page 120.

If the track needs adjustment:

6. Loosen the rear idler shaft bolt.
7. Loosen the locknuts.

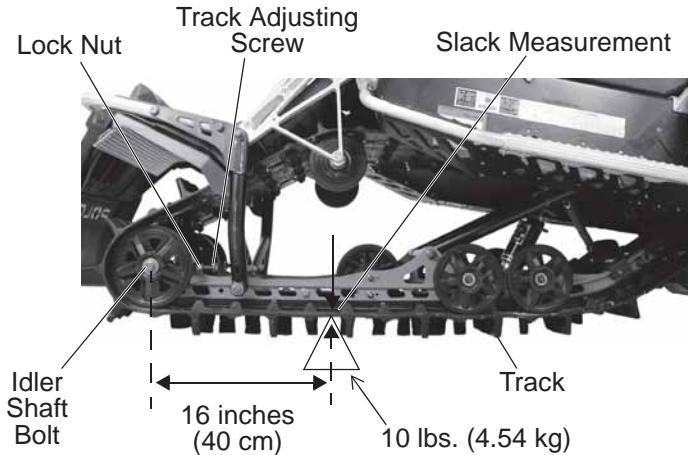

8. Tighten or loosen the track adjusting screws to provide equal adjustment on both sides of the track.
 9. Repeat the measurement on the other side of the track.
- TIP:** Check more frequently when the snowmobile is new or if studs are installed.
10. Remove the weight. Start the engine and slowly rotate the track at least five revolutions. Let the track come to a stop (do not apply brakes).
 11. Check track alignment (see page 122) and adjust as necessary.
 12. Tighten the locknuts.
 13. Tighten idler shaft bolts to 35 ft-lbs (47.5 Nm).

MAINTENANCE

Track Maintenance

Track Alignment

Periodically check that the track is centered and running evenly on the slide rails. Misalignment will cause excessive wear to the track and slide rail.

1. Safely support the rear of the snowmobile with the track off the ground.
2. Start the engine and apply a small amount of throttle until the track turns slowly at least five complete revolutions. Stop the engine and let the track come to a stop (do not apply brakes).

3. Inspect track alignment by looking through the track window to make sure the rails are evenly spaced on each side. If the track runs to the left, loosen the idler shaft bolts, then loosen the left locknut and tighten the left adjusting bolt. If the track runs to the right, loosen the idler shaft bolts, then loosen the right locknut and tighten the right adjusting bolt.

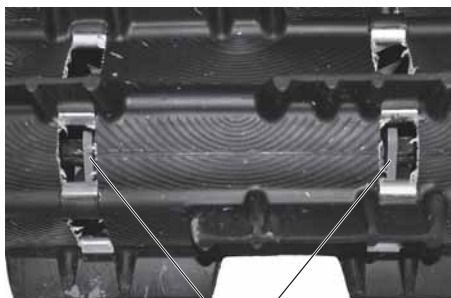

Rails

4. After adjustments are complete, tighten the locknuts.
5. Tighten the idler shaft bolts.
Torque: 35 ft-lbs (47.5 Nm)
6. Repeat steps 2 and 3 to verify proper alignment.

Steering System

Front Suspension Inspection

WARNING! Improper fastener torque or front suspension component damage may cause loss of steering control, resulting in serious injury or death. See your POLARIS dealer.

Each week, or before a long ride, check the following items. If component damage or loose fasteners are found, see your POLARIS dealer for service.

- Upper / Lower control arms
- Spindles
- Fasteners (X in illustration)
- Skis, ski loops, ski stops, skags/carbides
- Tie rods, rod ends, tie rod boots
- Sway bar / sway bar linkage

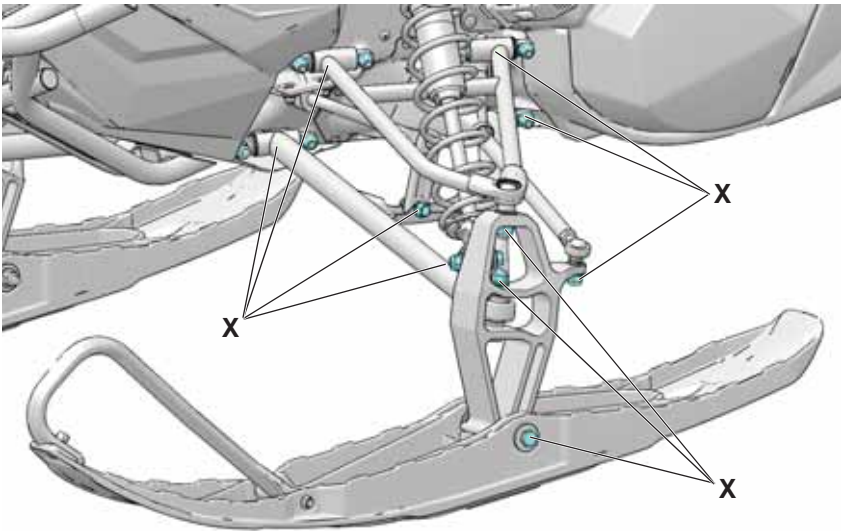

MAINTENANCE

Steering System

Ski Alignment

WARNING! Improper ski alignment or adjustment may cause loss of steering control, resulting in serious injury or death. Do not attempt to change the ski alignment or toe adjustment. See your POLARIS dealer.

If the steering feels heavy, or if the snowmobile seems to pull or dart to the side, ski alignment may need adjustment. Refer to the service manual or see your dealer for this service.

Ski Toe Settings

WARNING! Improper ski toe adjustment may cause loss of steering control, resulting in serious injury or death. Do not attempt to change toe adjustment. See your POLARIS dealer.

The skis on your snowmobile are set with a small amount of toe-out at the factory. You can inspect the toe setting by following the procedure below. If adjustments are required, refer to the service manual or see your dealer for this service.

1. Place the handlebars in a straight-ahead position.
2. With only vehicle weight compressing the suspension, measure 10 inches (25.4 cm) forward from the center of the ski mounting bolt. See illustration. At this point, measure between the skis. This is measurement X.
3. Perform the same measurement rearward from the center of the ski mounting bolt. This is measurement Y.
4. The X measurement should be $1/8$ - $1/4$ inch (3-6 mm) greater than the Y measurement.

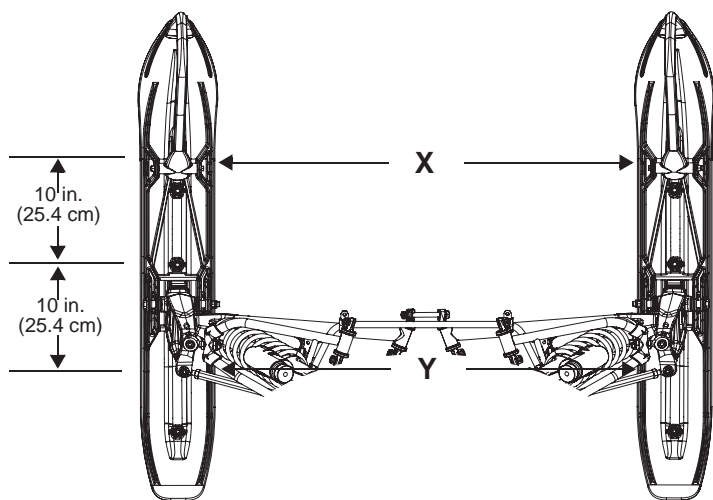

Steering System

Ski Skags

WARNING! Worn skis and/or skags will adversely affect handling. Loss of vehicle control may result, causing serious injury or death. See your dealer's studding chart for recommended skags. If you install longer or more aggressive carbide skags than the original equipment, it may also be necessary to add track studs to maintain proper vehicle control while turning on hard-packed snow or ice.

Check skags before each use of the snowmobile to ensure positive steering characteristics. Skags must be replaced when worn to half their original diameter.

TIP: Carbide skags must be replaced if any abnormal wear or chipping is found.

Inspect carbide for damage or wear



Ski Skag Replacement

1. Raise and support the front of the snowmobile so the skis are approximately 6 inches (15.2 cm) from the ground.
2. Remove the attaching nuts and pry the skag downward.
3. Remove the front end of the skag.
4. Remove the rear end of the skag.
5. Reverse the steps to install a skag. Tighten the nuts.

Torque: 7 ft-lbs (10 Nm)

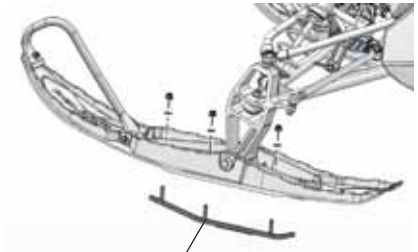

Ski Skag

MAINTENANCE

Front Suspension Control Arms

Control Arm Pivot Adjustment

The upper and lower control arms feature slotted pivots to allow for adjustment to compensate for bushing wear.

NOTE: Upper control arm shown. Procedure is the same for lower control arm adjustment.

1. Loosen the four lock nuts.

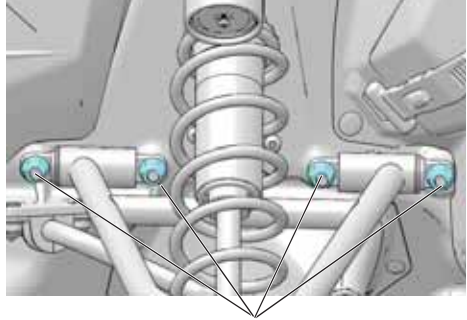

Loosen Nuts

2. From the bushing side of each pivot, push the pivot toward the control arm.
3. While holding the pivot(s) in place, tighten the lock nuts.

Torque: 30 ft-lbs (41 Nm)

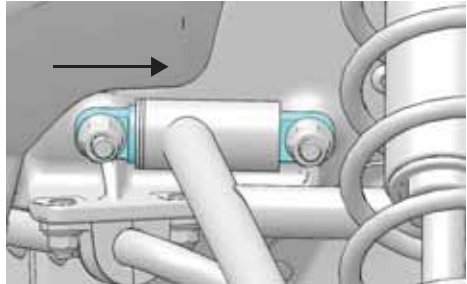

Rear Suspension

Rear Suspension Inspection

WARNING! Improper fastener torque or rear suspension component damage may cause loss of vehicle control, resulting in serious injury or death. See your POLARIS dealer.

Each week, or before a long ride, check the following items. If component damage or loose fasteners are found, see your POLARIS dealer for service.

- Rear crank / rear pivots
- Rear idler wheels / shaft
- Bogie / carrier wheels / shafts / fasteners
- Front torque arm
- Fasteners (X in illustration)
- Shocks
- Rail sliders
- Track

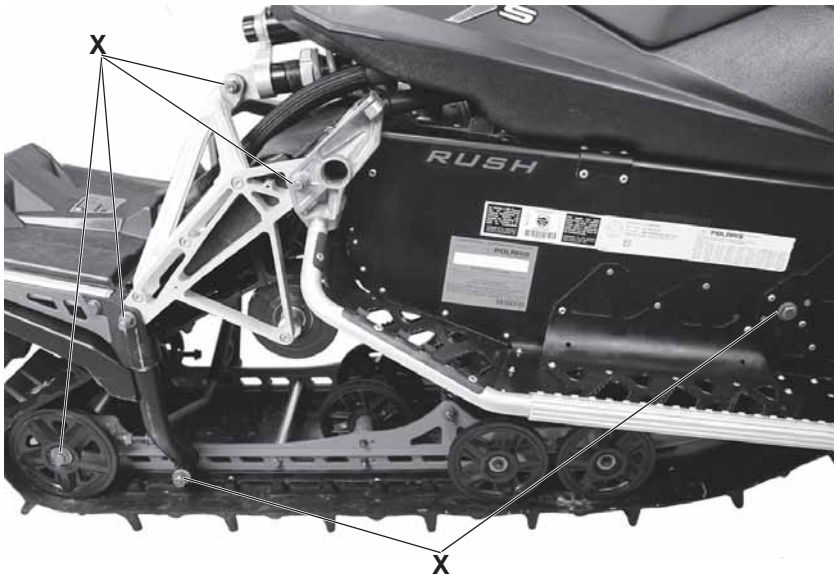

MAINTENANCE

Rear Suspension

Rail Slide Wear

Measure slide thickness at several points along the rail. Have your dealer replace the slide when it's worn down to the top of the wear limit indicator groove. Do not operate the snowmobile if slide thickness measures less than $7/16$ inch (1.1 cm).

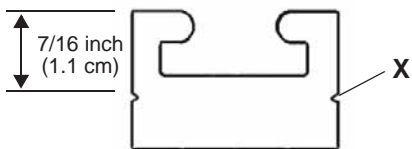

Battery (if equipped)

WARNING! Improperly connecting or disconnecting battery cables can result in an explosion and cause serious injury or death. When removing the battery, always disconnect the negative (black) cable first. When reinstalling the battery, always connect the negative (black) cable last.

Battery Removal

CAUTION! Hot exhaust system parts can cause burns. Allow adequate time for the exhaust system to cool. Never perform this procedure with the engine running.

1. Remove the right side panel.
2. Remove the two plastic rivets (1) securing the console panel to the chassis.
3. Remove the plastic rivet (2) securing the fender to the chassis.
4. Remove the rubber hold-down strap (3).
5. Disconnect the black (negative) battery cable first.
6. Disconnect the red (positive) battery cable last.

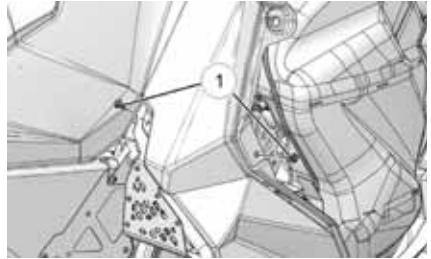

MAINTENANCE

Battery (if equipped)

Battery Removal

7. Remove the screw (4) securing the battery shield to the chassis.



8. Remove the battery shield (5).
9. Pull the fender away from the battery compartment and remove the battery.

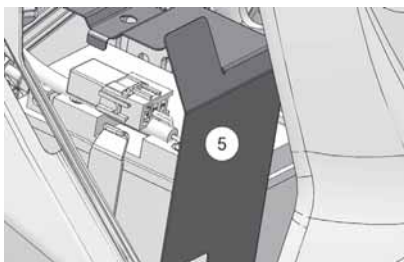

10. With the battery removed from the snowmobile, the battery bracket can be removed to access the chaincase. Remove the two nuts (6) and the screw (7) that secure the bracket to the chassis. Remove the bracket.

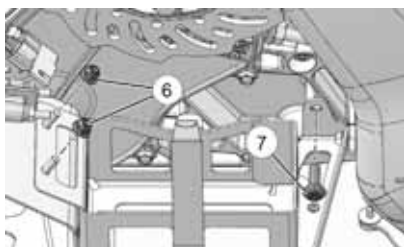

Battery (if equipped)

Battery Installation

When installing a new battery, make sure it's fully charged prior to its initial use. Using a new battery that has not been fully charged can damage the battery and result in a shorter life. It can also hinder vehicle performance. Follow the battery charging instructions on page 132 before installing the battery.

1. Ensure that the battery is fully charged.
2. If the battery bracket was removed, reinstall the bracket.
3. Tighten the nuts.
Torque: 7 ft-lbs (10 Nm)
4. Tighten the screw.
Torque: 22 ft-lbs (30 Nm)
5. Place the battery in the battery holder.
6. Connect and tighten the red (positive) cable first.
7. Connect and tighten the black (negative) cable last.
8. Verify that cables are properly routed.
9. Install the battery shield. Tighten the shield screw.
Torque: 7 ft-lbs (10 Nm)
10. Install the right fender using the plastic rivet.
11. Reinstall the console using the two plastic rivets.
12. Reinstall the side panel.

Battery Storage

Whenever the vehicle is not used for a period of three months or more, remove the battery from the vehicle, ensure that it's fully charged, and store it out of the sun in a cool, dry place. Check battery voltage each month during storage and recharge as needed to maintain a full charge.

TIP: Battery charge can be maintained by using a POLARIS Battery Tender™ charger or by charging about once a month to make up for normal self-discharge. Battery Tender™ can be left connected during the storage period, and will automatically charge the battery if the voltage drops below a pre-determined point.

MAINTENANCE

Battery (if equipped)

Battery Charging

The following battery charging instructions apply only to the installation of a sealed battery. Read all instructions before proceeding with the installation of this battery.

The sealed battery is already filled with electrolyte and has been sealed and *fully charged* at the factory. *Do not ever pry the sealing strip off* or add any other fluid to this battery.

The single most important thing about maintaining a sealed battery is to keep it fully charged. Since the battery is sealed and the sealing strip cannot be removed, you must use a voltmeter or multimeter to measure DC voltage.

Battery (if equipped)

Battery Charging

For a refresh charge, follow all instructions carefully.

1. Check the battery voltage with a voltmeter or multimeter. A fully charged battery will register 12.8 V or higher.
2. If the voltage is less than 12.8 volts, recharge the battery at 1.2 amps or less until the battery voltage is 12.8 or greater.

Tip: When using an automatic charger, refer to the charger manufacturer's instructions for recharging. When using a constant current charger, use the following guidelines for recharging.

WARNING! An overheated battery may explode, causing severe injury or death. Always watch charging times carefully. Stop charging if the battery becomes very warm to the touch. Allow it to cool before resuming charging.

Tip: Always verify battery condition before and 1-2 hours after the end of charging.

State of Charge	Voltage	Action	Charge Time <small>(Using constant current charger @ standard amps specified on top of battery)</small>
100%	12.8-13.0 volts	None, check at 3 mos. from date of manufacture	None required
75%-100%	12.5-12.8 volts	May need slight charge, if no charge given, check in 3 months	3-6 hours
50%-75%	12.0-12.5 volts	Needs charge	5-11 hours
25%-50%	11.5-12.0 volts	Needs charge	At least 13 hours, verify state of charge
0%-25%	11.5 volts or less	Needs charge with desulfating charger	At least 20 hours

MAINTENANCE

Fall Tune-Up

For maximum performance, arrange for a fall service tune-up with your POLARIS dealer. His experienced and trained service technician will keep your snowmobile in peak operating condition.

Matte Clear Coat Cleaning (if equipped)

Matte finish products are prone to trapping dirt, oils and other contaminants. POLARIS Industries recommends cleaning with warm water and a mild dish detergent. Use a soft sponge to gently rub the surface and rinse with clean warm water. For stubborn stains such as grease or oil use a citrus based cleaner (3M Citrus Base Cleaner recommended). Spray onto the area to be cleaned and rub with a soft sponge. Allow to sit for a couple of minutes and wash away with clean warm water. Repeat as necessary to clean the surface.

NOTICE: Never use a polishing/buffing wax or any sponge that has an abrasive surface. These products will buff the matte surface of the finish resulting in a glossy finish. It is not recommended that you clean matte finishes with a pressure washer as this will further imbed contaminants into the clear coat and possibly damage the labels.

Extended Storage

Off-season or extended storage of your snowmobile requires preventive measures to aid against deterioration and to prolong the useful life of many components. See page 137 for the part numbers of POLARIS products.

Cleaning and Preservation

Proper storage starts with cleaning, washing, and waxing the hood, side panels, chassis, and plastic parts. Wipe down remaining surfaces with a damp cloth. Clean and touch up with paint any rusted or previously painted surfaces. Be sure that corrosive salt and acids are removed from surfaces before beginning preservation with waxes and rust inhibitors (grease, oil or paint).

The snowmobile should be stored in a dry garage or shed, out of direct sunlight, and covered with a fabric snowmobile cover. Plastic tarp may cause condensation to form and damage snowmobile components.

Battery Storage

Whenever the vehicle is not used for a period of three months or more, remove the battery from the vehicle, ensure that it's fully charged, and store it out of the sun in a cool, dry place. Check battery voltage each month during storage and recharge as needed to maintain a full charge.

MAINTENANCE

Extended Storage

Clutch and Drive System

Remove the drive belt and store in a cool dry location. Do not lubricate clutch components, except the driven clutch shaft bushing as outlined in the Master Repair Manual. See your dealer.

Engine Protection

Proper preparation of the engine and fuel system is vital to the prevention of rust and corrosion on precision engine parts during storage. Whenever the snowmobile is stored for a period of more than 60 days, the engine must be fogged with fogging oil. Follow the engine fogging instructions provided on the container.

Always add Carbon Clean or a fuel conditioner/stabilizer to the fuel tank. Follow the instructions on the container, running the engine for five minutes to get additives through the entire fuel system. Top off with fresh fuel. *Do not allow the snowmobile to run out of fuel.*

Electrical Connections

Replace worn or frayed electrical wire and connectors. Be sure wiring harness is properly secured away from sharp edges, steering linkage, moving parts, and hot exhaust parts.

Track and Suspension

Moderate track tension should be maintained during summer storage. The snowmobile should be supported off the ground to allow the track to hang freely.

Transporting the Snowmobile

Whenever the snowmobile is transported:

1. Be sure the fuel cap and oil cap are installed correctly.
2. Tie the snowmobile to the transporting unit securely using suitable straps.
3. Remove the ignition key to prevent loss.

POLARIS PRODUCTS

Part No.	Description
Engine Lubricants	
2870791	Fogging Oil (12 oz. Aerosol)
2877882	VES 2-Cycle Oil (qt./.95 l)
2877953	VES 2-Cycle Engine Oil (2 qt./1.9 l)
2877883	VES 2-Cycle Engine Oil (gal./3.8 l)
2877884	VES 2-Cycle Engine Oil (2.5 gal./9.5 l)
Chaincase Lubricants	
2873105	SCL - Synthetic Chaincase Lubricant (qt./.95 l)
2873106	SCL - Synthetic Chaincase Lubricant (gal./3.8 l)
Grease/Specialized Lubricants	
2871312	Grease Gun Kit, All Season (3 oz./89 ml)
2871322	All Season Grease (3 oz./89 ml cartridge)
2871423	All Season Grease (14 oz./414 ml cartridge)
2871329	Dielectric Grease (Nyogel™)
Coolant	
2880514	POLARIS Extended Life Antifreeze 50/50 Premix (qt./.95 l)
2880513	POLARIS Extended Life Antifreeze 50/50 Premix (gal./3.8 l)
Additives/Miscellaneous	
2871326	Carbon Clean
2870652	Fuel Stabilizer
2872189	DOT4 Brake Fluid
2872893	Engine Degreaser
2870505	Isopropyl Fuel De-Icer

SPECIFICATIONS

600 RUSH PRO-S

Capacities and Dimensions	
Body Style	AXYS
Rider Capacity	1
Coolant Capacity	4 qts. (3.8 l)
Chaincase Oil Capacity	Fill to Spill / 8 - 10 oz. (237 - 296 ml) Dependent on sprocket / chain size
Fuel Tank Capacity	12 gal. (45.4 l)
Height	46 inches (117 cm)
Length	114 inches (289.6 cm)
Estimated Dry Weight	432 lbs. (196 kg)
Oil Capacity (qts./l)	3.8 qts. (112.4 l)
Designed Width (in./cm)	47 inches (119.4 cm)
Ski Center Distance	42.5 inches (108 cm)
Brake Type Fluid	Hayes Phantom Floating Piston DOT 4
Drive Clutch Center Distance	10.625 inches (26.97cm)
Drive Belt Type Projected Width	PBO- Double Cog, Cut Finish 1.46 inches (3.7 cm)
Drive / Driven Clutches	P-85 / Team LWT
Reverse	POLARIS Electronic Reverse Control (PERC)
Front / Rear Travel	9.3 in. (23.6 cm) / 13.6 in. (34.5 cm)
Engine and Cooling	
Engine	S4868-6044-OI6P
Displacement	599cc
Cylinders	2
Bore x Stroke (mm)	77.25 x 64
Alternator Output	400 watt
Throttle Body	Mikuni
Oil Injection	Electronic Oil Pump
Throttle Body Bore Size	46 mm
Idle RPM	1700 +/- 200
Operating RPM	8250 +/- 200
Cooling Thermostat Opening Temp.	Liquid 120°F (49°C)
Ignition Type	Multi-Dimensional CDI
Ignition Timing	18° @ idle 1700 RPM w/120°F (49°C) water temp
Spark Plug / Gap	NGK BPR9ES /.027 inches (0.7 mm)
Recommended Fuel Octane	91 non-oxygenated recommended (87 oxygenated minimum)

SPECIFICATIONS

600 RUSH PRO-S

Clutching Chart					
ALTITUDE Meters (Feet)	Drive Clutch Shift Weight	Drive Clutch Spring	Driven Clutch Spring	Driven Helix	Chaincase Gearing/ Pitch
*Shaded cells indicate factory settings.					
0-600 (0-2000)	10-64 1321585	140/330 7043829	Black/Purple 7043363	48/42-.36 5139626	22:41-70
600-1200 (2000-4000)	10-62 1321586				
1200-1800 (4000-6000)	10-60 1321587				
1800-2400 (6000-8000)	10-58 1321588				
2400-3000 (8000-10000)	10-56 1321684				21:42-70
3000-3600 (10000-12000)	10A-L 1321531				
NOTE: Use 2 gram lighter shift weights when operating in temperatures above 40°F (5°C).					

600 RUSH PRO-S Traction / Control

Traction / Control	
Track / Pitch	15 x 120 x 1.25 Ripsaw II / 2.86
Maximum Stud Length Tunnel Protection	1.325 in. (3.36 cm) Integrated
IFS Shocks	Walker Evans Piggyback / Compression Adj.
FTS Shock	Walker Evans Piggyback / Compression Adj.
RTS Shock	Walker Evans Piggyback / Compression Adj.
Ski / Carbide	PRO-STEER / 4 in. (10.16 cm)

SPECIFICATIONS

600 RUSH PRO-X (International)

Capacities and Dimensions	
Body Style	AXYS
Rider Capacity	1
Coolant Capacity	4 qts. (3.8 l)
Chaincase Oil Capacity	Fill to Spill / 8 - 10 oz. (237 - 296 ml) Dependent on sprocket / chain size
Fuel Tank Capacity	12 gal. (45.4 l)
Height	46 inches (117 cm)
Length	114 inches (289.6 cm)
Estimated Dry Weight	432 lbs. (196 kg)
Oil Capacity (qts./l)	3.8 qts. (112.4 l)
Designed Width (in./cm)	47 inches (119.4 cm)
Ski Center Distance	42.5 inches (108 cm)
Brake Type Fluid	Hayes Phantom Floating Piston DOT 4
Drive Clutch Center Distance	10.625 inches (26.97cm)
Drive Belt Type Projected Width	PBO- Double Cog, Cut Finish 1.46 inches (3.7 cm)
Drive / Driven Clutches	P-85 / Team LWT
Reverse	POLARIS Electronic Reverse Control (PERC)
Front / Rear Travel	9.9 in. (25.2 cm) / 13.6 in. (34.5 cm)
Engine and Cooling	
Engine	S4868-6044-OI6P
Displacement	599cc
Cylinders	2
Bore x Stroke (mm)	77.25 x 64
Alternator Output	400 watt
Throttle Body	Mikuni
Oil Injection	Electronic Oil Pump
Throttle Body Bore Size	46 mm
Idle RPM	1700 +/- 200
Operating RPM	8250 +/- 200
Cooling Thermostat Opening Temp.	Liquid 120°F (49°C)
Ignition Type	Multi-Dimensional CDI
Ignition Timing	18° @ idle 1700 RPM w/120°F (49°C) water temp
Spark Plug / Gap	NGK BPR9ES /.027 inches (0.7 mm)
Recommended Fuel Octane	91 non-oxygenated recommended (87 oxygenated minimum)

SPECIFICATIONS

600 RUSH PRO-X (International)

Clutching Chart					
ALTITUDE Meters (Feet)	Drive Clutch Shift Weight	Drive Clutch Spring	Driven Clutch Spring	Driven Helix	Chaincase Gearing/ Pitch
*Shaded cells indicate factory settings.					
0-600 (0-2000)	10-64 1321585	140/330 7043829	Black/Purple 7043363	48/42-.36 5139626	22:41-70
600-1200 (2000-4000)	10-62 1321586				
1200-1800 (4000-6000)	10-60 1321587				
1800-2400 (6000-8000)	10-58 1321588				
2400-3000 (8000-10000)	10-56 1321684				21:42-70
3000-3600 (10000-12000)	10A-L 1321531				
NOTE: Use 2 gram lighter shift weights when operating in temperatures above 40°F (5°C).					

600 RUSH PRO-X (International) Traction / Control

Traction / Control	
Track / Pitch	15 x 120 x 1.75 Backcountry X / 2.86
Maximum Stud Length Tunnel Protection	Not Recommended
IFS Shocks	Walker Evans Piggyback / Compression Adj.
FTS Shock	Walker Evans Piggyback / Compression Adj.
RTS Shock	Walker Evans Piggyback / Compression Adj.
Ski / Carbide	PRO-STEER / 4 in. (10.16 cm)

SPECIFICATIONS

600 SWITCHBACK PRO-S

Capacities and Dimensions	
Body Style	AXYS
Rider Capacity	1
Coolant Capacity	4 qts. (3.8 l)
Chaincase Oil Capacity	Fill to Spill / 8 - 10 oz. (237 - 296 ml) Dependent on sprocket / chain size
Fuel Tank Capacity	12 gal. (45.4 l)
Height	46 inches (116.8 cm)
Length	121 inches (307.4 cm)
Estimated Dry Weight	447 lbs. (202.8 kg)
Oil Capacity (qts./l)	3.8 qts. (112.4 l)
Designed Width (in./cm)	47 inches (119.4 cm)
Ski Center Distance	42.5 inches (108 cm)
Brake Type Fluid	Hayes Phantom Floating Piston DOT 4
Drive Clutch Center Distance	10.625 inches (26.97cm)
Drive Belt Type Projected Width	PBO- Double Cog, Cut Finish 1.46 inches (3.7 cm)
Drive / Driven Clutches	P-85 / Team LWT
Reverse	POLARIS Electronic Reverse Control (PERC)
Front / Rear Travel	9.3 in. (23.6 cm) / 13.4 in. (34 cm)
Engine and Cooling	
Engine	S4868-6044-OI6P
Displacement	599cc
Cylinders	2
Bore x Stroke (mm)	77.25 x 64
Alternator Output	400 watt
Throttle Body	Mikuni
Oil Injection	Electronic Oil Pump
Throttle Body Bore Size	46 mm
Idle RPM	1700 +/- 200
Operating RPM	8250 +/- 200
Thermostat Opening Temp.	120°F (49°C)
Ignition Type	Multi-Dimensional CDI
Ignition Timing	18° @ idle 1700 RPM w/120°F (49°C) water temp
Spark Plug / Gap	NGK BPR9ES /.027 inches (0.7 mm)
Recommended Fuel Octane	91 non-oxygenated recommended (87 oxygenated minimum)

SPECIFICATIONS

600 SWITCHBACK PRO-S

Clutching Chart					
ALTITUDE Meters (Feet)	Drive Clutch Shift Weight	Drive Clutch Spring	Driven Clutch Spring	Driven Helix	Chaincase Gearing/ Pitch
*Shaded cells indicate factory settings.					
0-600 (0-2000)	10-64 1321585	140/330 7043829	Black/Purple 7043363	48/42-.36 5139626	22:41-70
600-1200 (2000-4000)	10-62 1321586				
1200-1800 (4000-6000)	10-60 1321587				
1800-2400 (6000-8000)	10-58 1321588				
2400-3000 (8000-10000)	10-56 1321684				21:42-70
3000-3600 (10000-12000)	10A-L 1321531				
NOTE: Use 2 gram lighter shift weights when operating in temperatures above 40°F (5°C).					

600 SWITCHBACK PRO-S

Traction / Control	
Track / Pitch	15 x 137 x 1.25 Ripsaw II / 2.86
Maximum Stud Length Tunnel Protection	1.325 in. (3.36 cm) Integrated
IFS Shocks	Walker Evans Piggyback / Compression Adj.
FTS Shock	Walker Evans Piggyback / Compression Adj.
RTS Shock	Walker Evans Piggyback / Compression Adj.
Ski / Carbide	PRO-STEER / 4 in. (10.16 cm)

SPECIFICATIONS

600 SWITCHBACK PRO-X (International)

Capacities and Dimensions	
Body Style	AXYS
Rider Capacity	1
Coolant Capacity	4 qts. (3.8 l)
Chaincase Oil Capacity	Fill to Spill / 8 - 10 oz. (237 - 296 ml) Dependent on sprocket / chain size
Fuel Tank Capacity	12 gal. (45.4 l)
Height	46 inches (116.8 cm)
Length	121 inches (307.4 cm)
Estimated Dry Weight	447 lbs. (202.8 kg)
Oil Capacity (qts./l)	3.8 qts. (112.4 l)
Designed Width (in./cm)	47 inches (119.4 cm)
Ski Center Distance	42.5 inches (108 cm)
Brake Type Fluid	Hayes Phantom Floating Piston DOT 4
Drive Clutch Center Distance	10.625 inches (26.97cm)
Drive Belt Type Projected Width	PBO- Double Cog, Cut Finish 1.46 inches (3.7 cm)
Drive / Driven Clutches	P-85 / Team LWT
Reverse	POLARIS Electronic Reverse Control (PERC)
Front / Rear Travel	9.9in. (25.2 cm) / 13.4 in. (34 cm)
Engine and Cooling	
Engine	S4868-6044-OI6P
Displacement	599cc
Cylinders	2
Bore x Stroke (mm)	77.25 x 64
Alternator Output	400 watt
Throttle Body	Mikuni
Oil Injection	Electronic Oil Pump
Throttle Body Bore Size	46 mm
Idle RPM	1700 +/- 200
Operating RPM	8250 +/- 200
Thermostat Opening Temp.	120°F (49°C)
Ignition Type	Multi-Dimensional CDI
Ignition Timing	18° @ idle 1700 RPM w/120°F (49°C) water temp
Spark Plug / Gap	NGK BPR9ES /.027 inches (0.7 mm)
Recommended Fuel Octane	91 non-oxygenated recommended (87 oxygenated minimum)

SPECIFICATIONS

600 SWITCHBACK PRO-X (International)

Clutching Chart					
ALTITUDE Meters (Feet)	Drive Clutch Shift Weight	Drive Clutch Spring	Driven Clutch Spring	Driven Helix	Chaincase Gearing/ Pitch
*Shaded cells indicate factory settings.					
0-600 (0-2000)	10-64 1321585	140/330 7043829	Black/Purple 7043363	48/42-.36 5139626	22:41-70
600-1200 (2000-4000)	10-62 1321586				
1200-1800 (4000-6000)	10-60 1321587				
1800-2400 (6000-8000)	10-58 1321588				
2400-3000 (8000-10000)	10-56 1321684				21:42-70
3000-3600 (10000-12000)	10A-L 1321531				
NOTE: Use 2 gram lighter shift weights when operating in temperatures above 40°F (5°C).					

600 SWITCHBACK PRO-X (International)

Traction / Control	
Track / Pitch	15 x 137 x 1.75 Backcountry X / 2.86
Maximum Stud Length Tunnel Protection	Not Recommended
IFS Shocks	Walker Evans Piggyback / Compression Adj.
FTS Shock	Walker Evans Piggyback / Compression Adj.
RTS Shock	Walker Evans Piggyback / Compression Adj.
Ski / Carbide	RMK Wide / 3 in. (7.62 cm)

SPECIFICATIONS

600 SWITCHBACK ADVENTURE

Capacities and Dimensions	
Body Style	AXYS
Rider Capacity	1
Coolant Capacity	4 qts. (3.8 l)
Chaincase Oil Capacity	Fill to Spill / 8 - 10 oz. (237 - 296 ml) Dependent on sprocket / chain size
Fuel Tank Capacity	12 gal. (45.4 l)
Height	49 inches (124.5 cm)
Length	121 inches (307.4 cm)
Estimated Dry Weight	492 lbs (223.2 kg)
Oil Capacity (qts./l)	3.8 qts. (112.4 l)
Designed Width (in./cm)	47 inches (119.4 cm)
Ski Center Distance	42.5 inches (108 cm)
Brake Type Fluid	Hayes Phantom Floating Piston DOT 4
Drive Clutch Center Distance	10.625 inches (26.97cm)
Drive Belt Type Projected Width	PBO- Double Cog, Cut Finish 1.46 inches (3.7 cm)
Drive / Driven Clutches	P-85 / Team LWT
Reverse	POLARIS Electronic Reverse Control (PERC)
Front / Rear Travel	9.3 in. (23.6 cm) / 13.4 in. (34 cm)
Engine and Cooling	
Engine	S4868-6044-OI6P
Displacement	599cc
Cylinders	2
Bore x Stroke (mm)	77.25 x 64
Alternator Output	400 watt
Throttle Body	Mikuni
Oil Injection	Electronic Oil Pump
Throttle Body Bore Size	46 mm
Idle RPM	1700 +/- 200
Operating RPM	8250 +/- 200
Thermostat Opening Temp.	120°F (49°C)
Ignition Type	Multi-Dimensional CDI
Ignition Timing	18° @ idle 1700 RPM w/120°F (49°C) water temp
Spark Plug / Gap	NGK BPR9ES /.027 inches (0.7 mm)
Recommended Fuel Octane	91 non-oxygenated recommended (87 oxygenated minimum)

SPECIFICATIONS

600 SWITCHBACK ADVENTURE

Clutching Chart					
ALTITUDE Meters (Feet)	Drive Clutch Shift Weight	Drive Clutch Spring	Driven Clutch Spring	Driven Helix	Chaincase Gearing/ Pitch
*Shaded cells indicate factory settings.					
0-600 (0-2000)	10-64 1321585	140/330 7043829	Black/Purple 7043363	48/42-.36 5139626	22:41-70
600-1200 (2000-4000)	10-62 1321586				
1200-1800 (4000-6000)	10-60 1321587				
1800-2400 (6000-8000)	10-58 1321588				
2400-3000 (8000-10000)	10-56 1321684				21:42-70
3000-3600 (10000-12000)	10A-L 1321531				
NOTE: Use 2 gram lighter shift weights when operating in temperatures above 40°F (5°C).					

600 SWITCHBACK ADVENTURE

Traction / Control	
Track / Pitch	15 x 137 x 1.352 Cobra / 2.86
Maximum Stud Length Tunnel Protection	1.325 in. (3.36 cm) Integrated
IFS Shocks	Walker Evans Piggyback / Compression Adj.
FTS Shock	Walker Evans Piggyback / Compression Adj.
RTS Shock	Walker Evans Piggyback / Compression Adj.
Ski / Carbide	PRO-STEER / 4 in. (10.16 cm)

SPECIFICATIONS

600 SWITCHBACK ADVENTURE (International)

Capacities and Dimensions	
Body Style	AXYS
Rider Capacity	1
Coolant Capacity	4 qts. (3.8 l)
Chaincase Oil Capacity	Fill to Spill / 8 - 10 oz. (237 - 296 ml) Dependent on sprocket / chain size
Fuel Tank Capacity	12 gal. (45.4 l)
Height	49 inches (124.5 cm)
Length	121 inches (307.4 cm)
Estimated Dry Weight	492 lbs (223.2 kg)
Oil Capacity (qts./l)	3.8 qts. (112.4 l)
Designed Width (in./cm)	47 inches (119.4 cm)
Ski Center Distance	42.5 inches (108 cm)
Brake Type Fluid	Hayes Phantom Floating Piston DOT 4
Drive Clutch Center Distance	10.625 inches (26.97cm)
Drive Belt Type Projected Width	PBO- Double Cog, Cut Finish 1.46 inches (3.7 cm)
Drive / Driven Clutches	P-85 / Team LWT
Reverse	POLARIS Electronic Reverse Control (PERC)
Front / Rear Travel	9.9 in. (25.2 cm) / 13.4 in. (34 cm)
Engine and Cooling	
Engine	S4868-6044-OI6P
Displacement	599cc
Cylinders	2
Bore x Stroke (mm)	77.25 x 64
Alternator Output	400 watt
Throttle Body	Mikuni
Oil Injection	Electronic Oil Pump
Throttle Body Bore Size	46 mm
Idle RPM	1700 +/- 200
Operating RPM	8250 +/- 200
Thermostat Opening Temp.	120°F (49°C)
Ignition Type	Multi-Dimensional CDI
Ignition Timing	18° @ idle 1700 RPM w/120°F (49°C) water temp
Spark Plug / Gap	NGK BPR9ES /.027 inches (0.7 mm)
Recommended Fuel Octane	91 non-oxygenated recommended (87 oxygenated minimum)

SPECIFICATIONS

600 SWITCHBACK ADVENTURE (International)

Clutching Chart					
ALTITUDE Meters (Feet)	Drive Clutch Shift Weight	Drive Clutch Spring	Driven Clutch Spring	Driven Helix	Chaincase Gearing/ Pitch
*Shaded cells indicate factory settings.					
0-600 (0-2000)	10-64 1321585	140/330 7043829	Black/Purple 7043363	48/42-.36 5139626	22:41-70
600-1200 (2000-4000)	10-62 1321586				
1200-1800 (4000-6000)	10-60 1321587				
1800-2400 (6000-8000)	10-58 1321588				
2400-3000 (8000-10000)	10-56 1321684				21:42-70
3000-3600 (10000-12000)	10A-L 1321531				
NOTE: Use 2 gram lighter shift weights when operating in temperatures above 40°F (5°C).					

600 SWITCHBACK ADVENTURE (International)

Traction / Control	
Track / Pitch	15 x 137 x 1.75 Backcountry X / 2.86
Maximum Stud Length Tunnel Protection	Not Recommended
IFS Shocks	Walker Evans Piggyback / Compression Adj.
FTS Shock	Walker Evans Piggyback / Compression Adj.
RTS Shock	Walker Evans Piggyback / Compression Adj.
Ski / Carbide	International: RMK Wide / 3 in. (7.62 cm)

SPECIFICATIONS

800 RUSH PRO-S

Capacities and Dimensions	
Body Style	AXYS
Rider Capacity	1
Coolant Capacity	4 qts. (3.8 l)
Chaincase Oil Capacity	Fill to Spill / 8 - 10 oz. (237 - 296 ml) Dependent on sprocket / chain size
Fuel Tank Capacity	12 gal. (45.4 l)
Height	46 inches (117 cm)
Length	114 inches (289.6 cm)
Estimated Dry Weight	431 lbs. (195.5 kg)
Oil Capacity (qts./l)	3.8 qts. (112.4 l)
Designed Width (in./cm)	47 inches (119.4 cm)
Ski Center Distance	42.5 inches (108 cm)
Brake Type Fluid	Hayes Phantom Floating Piston DOT 4
Drive Clutch Center Distance	10.625 inches (26.97cm)
Drive Belt Type Projected Width	High Modulus PBO- Double Cog, Cut Finish 1.46 inches (3.7 cm)
Drive / Driven Clutches	P-85 / Team LWT
Reverse	POLARIS Electronic Reverse Control (PERC)
Front / Rear Travel	9.3 in. (23.6 cm) / 13.6 (34.5 cm)
Engine and Cooling	
Engine	S4834-8044-0I8P
Displacement	795cc
Cylinders	2
Bore x Stroke (mm)	85 x 70
Alternator Output	400 watt
Throttle Body	Mikuni
Oil Injection	Electronic Oil Pump
Throttle Body Bore Size	48 mm
Idle RPM	1700 +/- 200
Operating RPM	8250 +0/- 200
Thermostat Opening Temp.	120°F (49°C)
Ignition Type	Multi-Dimensional CDI
Ignition Timing	18° @ idle 1700 RPM w/120°F (49°C) water temp
Spark Plug / Gap	NGK BPR9ES /.027 inches (0.7 mm)
Recommended Fuel Octane	91 non-oxygenated recommended (87 oxygenated minimum)

SPECIFICATIONS

800 RUSH PRO-S

Clutching Chart					
ALTITUDE Meters (Feet)	Drive Clutch Shift Weight	Drive Clutch Spring	Driven Clutch Spring	Driven Helix	Chaincase Gearing/ Pitch
*Shaded cells indicate factory settings.					
0-600 (0-2000)	10-66 1321584	Gold 7041148	Blue / Black 7043064	58/44-.36	23-37-68
600-1200 (2000-4000)	10-64 1321585				
1200-1800 (4000-6000)	10-62 1321586				
1800-2400 (6000-8000)	10-60 1321587	140/330 7043829	Black 7043063		20-39-68
2400-3000 (8000-10000)					
3000-3600 (10000-12000)	10-58 1321588				

NOTE: Use 2 gram lighter shift weights when operating in temperatures above 40°F (5°C).

800 RUSH PRO-S

Traction / Control	
Track / Pitch	15 x 120 x 1.25 Ripsaw II / 2.86
Maximum Stud Length Tunnel Protection	1.325 in. (3.36 cm) Integrated
IFS Shocks	Walker Evans Piggyback / Compression Adj.
FTS Shock	Walker Evans Piggyback / Compression Adj.
RTS Shock	Walker Evans Piggyback / Compression Adj.
Ski / Carbide	PRO-STEER / 4 in. (10.16 cm)

SPECIFICATIONS

800 RUSH PRO-X

Capacities and Dimensions	
Body Style	AXYS
Rider Capacity	1
Coolant Capacity	4 qts. (3.8 l)
Chaincase Oil Capacity	Fill to Spill / 8 - 10 oz. (237 - 296 ml) Dependent on sprocket / chain size
Fuel Tank Capacity	12 gal. (45.4 l)
Height	48 inches (121.9 cm)
Length	114 inches (289.6 cm)
Estimated Dry Weight	435 lbs. (197.3 kg)
Oil Capacity (qts./l)	3.8 qts. (112.4 l)
Designed Width (in./cm)	47 inches (119.4 cm)
Ski Center Distance	42.5 inches (108 cm)
Brake Type Fluid	Hayes Phantom Floating Piston DOT 4
Drive Clutch Center Distance	10.625 inches (26.97cm)
Drive Belt Type Projected Width	High Modulus PBO- Double Cog, Cut Finish 1.46 inches (3.7 cm)
Drive / Driven Clutches	P-85 / Team LWT
Reverse	POLARIS Electronic Reverse Control (PERC)
Front / Rear Travel	9.9 in. (25.2 cm) / 13.6 in. (34.5 cm)
Engine and Cooling	
Engine	S4834-8044-0I8P
Displacement	795cc
Cylinders	2
Bore x Stroke (mm)	85 x 70
Alternator Output	400 watt
Throttle Body	Mikuni
Oil Injection	Electronic Oil Pump
Throttle Body Bore Size	48 mm
Idle RPM	1700 +/- 200
Operating RPM	8250 + 0/- 200
Thermostat Opening Temp.	120°F (49°C)
Ignition Type	Multi-Dimensional CDI
Ignition Timing	18° @ idle 1700 RPM w/120°F (49°C) water temp
Spark Plug / Gap	NGK BPR9ES /.027 inches (0.7 mm)
Recommended Fuel Octane	91 non-oxygenated recommended (87 oxygenated minimum)

SPECIFICATIONS

800 RUSH PRO-X

Clutching Chart					
ALTITUDE Meters (Feet)	Drive Clutch Shift Weight	Drive Clutch Spring	Driven Clutch Spring	Driven Helix	Chaincase Gearing/ Pitch
*Shaded cells indicate factory settings.					
0-600 (0-2000)	10-66 1321584	Gold 7041148	Blue / Black 7043064	58/44-.36	22-41-70
600-1200 (2000-4000)	10-64 1321585				
1200-1800 (4000-6000)	10-62 1321586				
1800-2400 (6000-8000)	10-60 1321587	140/330 7043829	Black 7043063		21-42-70
2400-3000 (8000-10000)					
3000-3600 (10000-12000)	10-58 1321588				

NOTE: Use 2 gram lighter shift weights when operating in temperatures above 40°F (5°C).

800 RUSH PRO-X

Traction / Control	
Track / Pitch	15 x 120 x 1.75 Backcountry X / 2.86
Maximum Stud Length	N/A
Tunnel Protection	N/A
IFS Shocks	Walker Evans Piggyback / Compression Adj.
FTS Shock	Walker Evans Piggyback / Compression Adj.
RTS Shock	Walker Evans Piggyback / Compression Adj.
Ski / Carbide	PRO-STEER / 4 in. (10.16 cm)

SPECIFICATIONS

800 SWITCHBACK PRO-S

Capacities and Dimensions	
Body Style	AXYS
Rider Capacity	1
Coolant Capacity	4 qts. (3.8 l)
Chaincase Oil Capacity	Fill to Spill / 8 - 10 oz. (237 - 296 ml) Dependent on sprocket / chain size
Fuel Tank Capacity	12 gal. (45.4 l)
Height	46 inches (117 cm)
Length	121 inches (307.4 cm)
Estimated Dry Weight	446 lbs. (202.3 kg)
Oil Capacity (qts./l)	3.8 qts. (112.4 l)
Designed Width (in./cm)	47 inches (119.4 cm)
Ski Center Distance	42.5 inches (108 cm)
Brake Type Fluid	Hayes Phantom Floating Piston DOT 4
Drive Clutch Center Distance	10.625 inches (26.97cm)
Drive Belt Type Projected Width	High Modulus PBO- Double Cog, Cut Finish 1.46 inches (3.7 cm)
Drive / Driven Clutches	P-85 / Team LWT
Reverse	POLARIS Electronic Reverse Control (PERC)
Front / Rear Travel	9.3 in. (23.6 cm) / 13.4 in. (34 cm)
Engine and Cooling	
Engine	S4834-8044-0I8P
Displacement	795 cc
Cylinders	2
Bore x Stroke (mm)	85 x 70
Alternator Output	400 watt
Throttle Body	Mikuni
Oil Injection	Electronic Oil Pump
Throttle Body Bore Size	48 mm
Idle RPM	1700 +/- 200
Operating RPM	8250 +0/- 200
Thermostat Opening Temp.	120°F (49°C)
Ignition Type	Multi-Dimensional CDI
Ignition Timing	18° @ idle 1700 RPM w/120°F (49°C) water temp
Spark Plug / Gap	NGK BPR9ES /.027 inches (0.7 mm)
Recommended Fuel Octane	91 non-oxygenated recommended (87 oxygenated minimum)

SPECIFICATIONS

800 SWITCHBACK PRO-S

Clutching Chart					
ALTITUDE Meters (Feet)	Drive Clutch Shift Weight	Drive Clutch Spring	Driven Clutch Spring	Driven Helix	Chaincase Gearing/ Pitch
*Shaded cells indicate factory settings.					
0-600 (0-2000)	10-66 1321584	Gold 7041148	Blue / Black 7043064	58/44-.36	23-37-68
600-1200 (2000-4000)	10-64 1321585				
1200-1800 (4000-6000)	10-62 1321586				
1800-2400 (6000-8000)	10-60 1321587	140/330 7043829	Black 7043063		20-39-68
2400-3000 (8000-10000)					
3000-3600 (10000-12000)	10-58 1321588				

NOTE: Use 2 gram lighter shift weights when operating in temperatures above 40°F (5°C).

800 SWITCHBACK PRO-S

Traction / Control	
Track / Pitch	15 x 137 x 1.25 Ripsaw II / 2.86
Maximum Stud Length Tunnel Protection	1.325 in. (3.36 cm) Integrated
IFS Shocks	Walker Evans Piggyback / Compression Adj.
FTS Shock	Walker Evans Piggyback / Compression Adj.
RTS Shock	Walker Evans Piggyback / Compression Adj.
Ski / Carbide	PRO-STEER / 4 in. (10.16 cm)

SPECIFICATIONS

800 SWITCHBACK PRO-X

Capacities and Dimensions	
Body Style	AXYS
Rider Capacity	1
Coolant Capacity	4 qts. (3.8 l)
Chaincase Oil Capacity	Fill to Spill / 8 - 10 oz. (237 - 296 ml) Dependent on sprocket / chain size
Fuel Tank Capacity	12 gal. (45.4 l)
Height	48 inches (121.9 cm)
Length	121 inches (307.4 cm)
Estimated Dry Weight	450 lbs. (204.1 kg)
Oil Capacity (qts./l)	3.8 qts. (112.4 l)
Designed Width (in./cm)	47 inches (119.4 cm)
Ski Center Distance	42.5 inches (108 cm)
Brake Type Fluid	Hayes Phantom Floating Piston DOT 4
Drive Clutch Center Distance	10.625 inches (26.97cm)
Drive Belt Type Projected Width	High Modulus PBO- Double Cog, Cut Finish 1.46 inches (3.7 cm)
Drive / Driven Clutches	P-85 / Team LWT
Reverse	POLARIS Electronic Reverse Control (PERC)
Front / Rear Travel	9.9 in. (25.2 cm) / 13.4 (34 cm)
Engine and Cooling	
Engine	S4834-8044-0I8P
Displacement	795 cc
Cylinders	2
Bore x Stroke (mm)	85 x 70
Alternator Output	400 watt
Throttle Body	Mikuni
Oil Injection	Electronic Oil Pump
Throttle Body Bore Size	48 mm
Idle RPM	1700 +/- 200
Operating RPM	8250 +0/- 200
Thermostat Opening Temp.	120°F (49°C)
Ignition Type	Multi-Dimensional CDI
Ignition Timing	18° @ idle 1700 RPM w/120°F (49°C) water temp
Spark Plug / Gap	NGK BPR9ES /.027 inches (0.7 mm)
Recommended Fuel Octane	91 non-oxygenated recommended (87 oxygenated minimum)

SPECIFICATIONS

800 SWITCHBACK PRO-X

Clutching Chart					
ALTITUDE Meters (Feet)	Drive Clutch Shift Weight	Drive Clutch Spring	Driven Clutch Spring	Driven Helix	Chaincase Gearing/ Pitch
*Shaded cells indicate factory settings.					
0-600 (0-2000)	10-66 1321584	Gold 7041148	Blue / Black 7043064	58/44-.36	22-41-70
600-1200 (2000-4000)	10-64 1321585				
1200-1800 (4000-6000)	10-62 1321586				
1800-2400 (6000-8000)	10-60 1321587	140/330 7043829	Black 7043063		21-42-70
2400-3000 (8000-10000)					
3000-3600 (10000-12000)	10-58 1321588				

NOTE: Use 2 gram lighter shift weights when operating in temperatures above 40°F (5°C).

800 SWITCHBACK PRO-X

Traction / Control	
Track / Pitch	15 x 137 x 1.75 Backcountry X / 2.86
Maximum Stud Length	N/A
Tunnel Protection	N/A
IFS Shocks	Walker Evans Piggyback / Compression Adj.
FTS Shock	Walker Evans Piggyback / Compression Adj.
RTS Shock	Walker Evans Piggyback / Compression Adj.
Ski / Carbide	PRO-STEER / 4 in. (10.16 cm) International: RMK Wide / 3 in. (7.62)

TROUBLESHOOTING

Engine Troubleshooting

Unless you have experience and training in two-cycle engine repair, see your dealer if technical problems arise.

Problem	Probable Cause	Solution
Erratic engine operating RPM during acceleration or load variations	Drive clutch binding	• SEE YOUR DEALER.
	Driven clutch malfunction	• SEE YOUR DEALER.
Harsh drive clutch engagement	Drive belt worn or too narrow	• Replace the drive belt.
	Excessive belt/sheave clearance	• SEE YOUR DEALER.
Drive belt turns over	Wrong belt for application	• Replace the drive belt.
	Clutch alignment out of spec	• SEE YOUR DEALER.
	Engine mount broken or loose	• Inspect and replace. SEE YOUR DEALER.
Machine fails to move	Clutch jammed	• Check for twisted belt or broken spring. SEE YOUR DEALER.
	Track jammed	• Foreign object may be caught or the rail slide melted to the track clips due to lack of lubrication. • Track may be iced up or frozen to the ground.
	Chaincase sprocket or chain jammed or broken	• Chain is loose or broken or chain tightener is loose. SEE YOUR DEALER.

TROUBLESHOOTING

Engine Troubleshooting

Problem	Probable Cause	Solution
Noise in drive system	Broken drive clutch components	• SEE YOUR DEALER.
	Bearing failure/chaincase, jackshaft, or front drive shaft	• SEE YOUR DEALER.
	Drive belt surface flat spots	• Inspect and replace as needed.
	Drive chain loose	• Inspect and adjust (or replace).
	Drive chain worn, sprocket teeth broken	• SEE YOUR DEALER.
Poor low RPM performance	Worn drive belt	• Inspect and replace as needed.
	Excessive belt/sheave clearance	• SEE YOUR DEALER.
	Sticky clutch	• SEE YOUR DEALER.
	Poor fuel quality	• Use 87-91 octane fuel (or higher).
Engine doesn't turn	Seized engine	• SEE YOUR DEALER. Seizure is a result of poor lubrication, inadequate fuel supply, broken parts or improper cooling.
	Hydrostatic lock	• Fuel may have entered the crankcase while the vehicle was standing or being transported. SEE YOUR DEALER to correct the cause. Drain plug(s) are located on the lower crankcase for emergency draining.

TROUBLESHOOTING

Engine Troubleshooting

Problem	Probable Cause	Solution
Engine turns but fails to start	Faulty ignition	<ul style="list-style-type: none"> Install new spark plug(s). If engine still fails to start, check for spark. If there's no spark, SEE YOUR DEALER.
	No fuel to engine	<ul style="list-style-type: none"> Make sure the fuel tank contains fuel. Ice may be in the fuel line, filter or pump. Add isopropyl alcohol to the fuel system.
	Poor engine compression	<ul style="list-style-type: none"> This indicates a major engine problem that must be repaired before operating. SEE YOUR DEALER.
Engine lacks power	Fouled or defective spark plug(s)	<ul style="list-style-type: none"> Replace the plug(s).
	Fuel filter (loss of high RPM power)	<ul style="list-style-type: none"> SEE YOUR DEALER.
	Plugged fuel filter or tank pick-up sock	<ul style="list-style-type: none"> SEE YOUR DEALER.
	Incorrect clutching	<ul style="list-style-type: none"> SEE YOUR DEALER.
Engine continually backfires	Faulty plug(s)	<ul style="list-style-type: none"> Change plug(s), ensure caps are seated.
	Fuel System	<ul style="list-style-type: none"> Dirt or ice may be in the fuel system (deicer should be added to non-ethanol fuel at all times for assurance against fuel line icing).
	Incorrect throttle freeplay or faulty switch	<ul style="list-style-type: none"> SEE YOUR DEALER.
Engine requires more than normal pulls to start	Poor fuel	<ul style="list-style-type: none"> Replace with fresh winter fuel.
	Not enough fuel getting to engine	<ul style="list-style-type: none"> SEE YOUR DEALER.
	Plugged fuel filter or tank pick-up sock	<ul style="list-style-type: none"> SEE YOUR DEALER.

TROUBLESHOOTING

Suspension Troubleshooting

Problem	Solution
Rear suspension bottoms too easily	<ul style="list-style-type: none">• Adjust rear track shock clicker stiffer (see pages 57 and 58).• Verify rear spring is not broken / dislodged.• Rebuild rear track shock (see your dealer).
Rides too stiff in rear	<ul style="list-style-type: none">• Adjust rear track shock clicker softer (• Check for binding suspension shafts and grease all pivot points.• Adjust rear track shock clicker to softer setting.• Check track tension (see page 120).
Too much weight transfer when climbing	<ul style="list-style-type: none">• Adjust rear shock spring (see pages 57 and 56).
Too little weight transfer when climbing	<ul style="list-style-type: none">• Adjust rear shock spring (see pages 57 and 58).
Machine darts from side to side	<ul style="list-style-type: none">• Check ski alignment (see page 124).• Make sure spindles and all steering components turn freely.• Check for excessive play in steering assembly (see your dealer).• Ensure skags are straight on skis.• Adjust rear shock spring (see pages 57 and 58).• Check rail slide/replace if worn (see page 128).
Front end pushes	<ul style="list-style-type: none">• Decrease front track shock spring preload in 1/8in. increments.• Increase front suspension shock spring preload in 1/8in. increments• Check for worn skags.• Adjust rear shock spring (see pages 57 and 58).• Check for binding front suspension shafts and steering components.
Steering is heavy	<ul style="list-style-type: none">• Make sure spindles and all steering components turn freely.• Check ski alignment (see page 124).• Check skags and skis for damage.• Adjust rear shock spring (see pages 57 and 58).• Increase front track shock spring preload in 1/8in. increments
Track skips / ratchets	<ul style="list-style-type: none">• Track tension too loose (see page)• Studs (if installed) are loose. Follow manufacture's installation instructions and re-torque studs.

TROUBLESHOOTING

Drive Belt Troubleshooting

Belt Wear/Burn Diagnosis	
Causes	Solutions
Driving at low RPM	<ul style="list-style-type: none"> • Drive at higher RPMs. Gear the machine down. Check belt deflection.
Parking brake engaged	<ul style="list-style-type: none"> • Verify parking brake is not engaged.
Insufficient warm-up	<ul style="list-style-type: none"> • Warm the engine at least five minutes. Take the drive belt off the snowmobile in extremely cold weather and warm it up. Break snowmobile loose from the snow.
Towing at low RPM	<ul style="list-style-type: none"> • Do not tow in deep snow. Use fast, aggressive throttle to engage clutch.
Riding with high RPM and slow speed (8000 RPM/10 MPH/16 km/h)	<ul style="list-style-type: none"> • Lower the gear ratio. Reduce RPM. Avoid riding in high ambient temperatures. Check for snow ingestion.
Ice and snow build-up between track and tunnel	<ul style="list-style-type: none"> • Warm the engine at least five minutes. Take the drive belt off the snowmobile in extremely cold weather and warm it up. Break snowmobile loose from the snow.
Poor engine performance	<ul style="list-style-type: none"> • Check for fouled plugs and water, ice or dirt in the fuel tank or fuel line.
Loading snowmobiles onto trailers	<ul style="list-style-type: none"> • Skis may gouge into trailers and prevent the drivetrain from spinning properly. Use enough speed to drive the snowmobile completely onto the trailer. Push and pull it to finish loading if necessary.
Clutch malfunction	<ul style="list-style-type: none"> • Inspect clutch components. See your dealer.
Slow, easy clutch engagement	<ul style="list-style-type: none"> • Use fast, aggressive throttle to engage clutch.

Service and Warranty Information

Obtaining Service and Warranty Assistance

Read and understand the service data and the POLARIS warranty information contained in this manual. Contact your POLARIS dealer for replacement parts, service or warranty. Your dealer receives frequent updates on changes, modifications and tips on snowmobile maintenance, which may supersede information contained in this manual. Your dealer is also familiar with POLARIS policies and procedures and will be happy to assist you.

When contacting us about parts, service, or warranty, always provide the following information:

1. Serial number
2. Model number
3. Dealer name
4. Date of purchase
5. Details of trouble experienced
6. Length of time and conditions of operation
7. Previous correspondence

Use the page provided near the front of your owner's manual to record the identification numbers of your snowmobile and its engine.

POLARIS Customer Service

United States & Canada: 1-800-POLARIS (1-800-765-2747)

French: 1-800-268-6334

WARRANTY

Limited Warranty

POLARIS Industries Inc., 2100 Highway 55, Medina, MN 55340 (POLARIS) gives a 12 MONTH LIMITED WARRANTY on all components of your POLARIS vehicle against defects in material or workmanship. This warranty covers parts and labor charges for repair or replacement of defective parts and begins on the date of purchase by the original retail purchaser. This warranty is transferable to another owner during the warranty period through a POLARIS dealer, but any such transfer will not extend the original term of the warranty. The duration of this warranty may vary by international region based upon local laws and regulations.

THIS WARRANTY MAY BE VOIDED BY ANY UNAPPROVED MODIFICATIONS TO THIS VEHICLE THAT AFFECT POWERTRAIN, EXHAUST, CHASSIS OR SUSPENSION.

Promotional warranties are sometimes offered by POLARIS, including but not limited to:

- Two-year extended engine coverage
- Two-year powertrain coverage
- Extended service contract

See your dealer for details and separate terms and conditions for any promotional warranties.

Registration

At the time of sale, the Warranty Registration Form must be completed by your dealer and submitted to POLARIS within ten days of purchase. Upon receipt of this registration, POLARIS will record the registration for warranty. No verification of registration will be sent to the purchaser as the copy of the Warranty Registration Form will be your proof of warranty coverage. If you have not signed the original registration and received the customer copy, please contact your dealer immediately. **NO WARRANTY COVERAGE WILL BE ALLOWED UNLESS YOUR VEHICLE IS REGISTERED WITH POLARIS.** Initial dealer preparation and set-up of your vehicle is very important in ensuring trouble-free operation. Purchasing a machine in the crate or without proper dealer set-up will void your warranty coverage.

WARRANTY

Warranty Coverage and Exclusions Limitations of Warranties and Remedies

This POLARIS Limited Warranty excludes any failures that are not caused by a defect in material or workmanship. THIS WARRANTY DOES NOT COVER CLAIMS OF DEFECTIVE DESIGN. This warranty also does not cover acts of God, accidental damage, normal wear and tear, abuse or improper handling. This warranty also does not cover any vehicle, component or part that has been altered structurally, modified, neglected, improperly maintained or used for racing, competition or purposes other than for which it was designed.

This warranty also excludes failures resulting from improper lubrication; improper engine timing; improper fuel; surface imperfections caused by external stress, heat, cold or contamination; operator error or abuse; improper component alignment, tension, adjustment or altitude compensation; failure due to snow, water, dirt or other foreign substance ingestion/contamination; improper maintenance; modified components; use of aftermarket components; unauthorized repairs; repairs made after the warranty period expires or by an unauthorized repair center; use of the product in competition or for commercial purposes. Warranty will not apply to any product which has been damaged by abuse, accident, fire or any other casualty not determined a defect of materials or workmanship.

This warranty excludes damages or failures caused by abuse, accident, fire or any other cause other than a defect in materials or workmanship and provides no coverage for consumable components, general wear items or any parts exposed to friction surfaces, stresses, environmental conditions and/or contamination for which they were not designed or not intended, including but not limited to the following items:

Skis	Ski wear rods
Tracks	Slide rails
Suspension components	Finished and unfinished surfaces
Brake components	Carburetor/Throttle body components
Seat components	Engine components
Clutches and components	Drive belts
Steering components	Hydraulic components
Batteries	Circuit breakers/Fuses
Light bulbs/Sealed beam lamps	Electronic components
Idler wheels	Spark Plugs
Sealants	Lubricants
Coolant	Filters
Fuel	

WARRANTY

Warranty Coverage and Exclusions Limitations of Warranties and Remedies

Lubricants and Fluids

1. Mixing oil brands or using non-recommended oil may cause engine damage. We recommend the use of POLARIS engine oil.
2. Damage or failure resulting from the use of non-recommended lubricants or fluids is not covered by this warranty.

This warranty provides no coverage for personal loss or expense, including mileage, transportation costs, hotels, meals, shipping or handling fees, product pick-up or delivery, replacement rentals, loss of product use, loss of profits, or loss of vacation or personal time.

THE EXCLUSIVE REMEDY FOR BREACH OF THIS WARRANTY SHALL BE, AT POLARIS' OPTION, REPAIR OR REPLACEMENT OF ANY DEFECTIVE MATERIALS, COMPONENTS, OR PRODUCTS. THE REMEDIES SET FORTH IN THIS WARRANTY ARE THE ONLY REMEDIES AVAILABLE TO ANY PERSON FOR BREACH OF THIS WARRANTY. POLARIS SHALL HAVE NO LIABILITY TO ANY PERSON FOR INCIDENTAL, CONSEQUENTIAL OR SPECIAL DAMAGES OF ANY DESCRIPTION, WHETHER ARISING OUT OF EXPRESS OR IMPLIED WARRANTY OR ANY OTHER CONTRACT, NEGLIGENCE, OR OTHER TORT OR OTHERWISE. THIS EXCLUSION OF CONSEQUENTIAL, INCIDENTAL AND SPECIAL DAMAGES IS INDEPENDENT FROM AND SHALL SURVIVE ANY FINDING THAT THE EXCLUSIVE REMEDY FAILED OF ITS ESSENTIAL PURPOSE.

THE IMPLIED WARRANTY OF FITNESS FOR A PARTICULAR PURPOSE IS EXCLUDED FROM THIS LIMITED WARRANTY. ALL OTHER IMPLIED WARRANTIES (INCLUDING BUT NOT LIMITED TO THE IMPLIED WARRANTY OF MERCHANTABILITY) ARE LIMITED IN DURATION TO THE ABOVE 12 MONTH WARRANTY PERIOD. POLARIS DISCLAIMS ALL EXPRESS WARRANTIES NOT STATED IN THIS WARRANTY. SOME STATES DO NOT PERMIT THE EXCLUSION OR LIMITATION OF INCIDENTAL OR CONSEQUENTIAL DAMAGES OR ALLOW LIMITATIONS ON THE DURATION OF IMPLIED WARRANTIES, SO THE ABOVE LIMITATIONS MAY NOT APPLY TO YOU IF INCONSISTENT WITH CONTROLLING STATE LAW.

How to Obtain Warranty Service

If your vehicle requires warranty service, you must take it to a POLARIS Servicing Dealer. When requesting warranty service you must present your copy of the Warranty Registration Form to the dealer. (THE COST OF TRANSPORTATION TO AND FROM THE DEALER IS YOUR RESPONSIBILITY.) POLARIS suggests that you use your original selling dealer; however, you may use any POLARIS Servicing Dealer to perform warranty service.

In the country where your product was purchased:

Warranty or service bulletin repairs must be done by an authorized POLARIS dealer. If you move or are traveling within the country where your product was purchased, warranty and service bulletin repairs may be requested from any authorized POLARIS dealer that sells the same line as your product.

Outside the country where your product was purchased:

If you are traveling temporarily outside the country where your product was purchased, you should take your product to an authorized POLARIS dealer. You must show the dealer photo identification from the country of the selling dealer's authorized location as proof of residence. Upon residence verification, the servicing dealer will be authorized to perform the warranty repair.

If you move:

If you move to another country, be sure to contact POLARIS Customer Assistance and the customs department of the destination country before you move. Product importation rules vary considerably from country to country. You may be required to present documentation of your move to POLARIS in order to continue your warranty coverage. You may also be required to obtain documentation from POLARIS in order to register your product in your new country. You should warranty register your product at a local POLARIS dealer in your new country immediately after you move to continue your warranty coverage and to ensure that you receive information and notices regarding your vehicle.

If you purchase from a private party:

If you purchase a POLARIS product from a private party, to be kept and used outside of the country in which the product was originally purchased, all warranty coverage will be denied. You must nonetheless register your product under your name and address with a local POLARIS dealer in your country to ensure that you receive safety information and notices regarding your product.

WARRANTY

Exported Products

EXCEPT WHERE SPECIFICALLY REQUIRED BY LAW, THERE IS NO WARRANTY OR SERVICE BULLETIN COVERAGE ON THIS PRODUCT IF IT IS SOLD OUTSIDE THE COUNTRY OF THE SELLING DEALER'S AUTHORIZED LOCATION. This policy does not apply to products that have received authorization for export from POLARIS. Dealers may not give authorization for export. You should consult an authorized dealer to determine this product's warranty or service coverage if you have any questions. This policy does not apply to products registered to government officials or military personnel on assignment outside the country of the selling dealer's authorized location. This policy does not apply to safety bulletins.

Notice

If your product is registered outside of the country where it was purchased and you have not followed the procedure set above, your product will no longer be eligible for warranty or service bulletin coverage of any kind, other than safety bulletins. Products registered to Government officials or military personnel on assignment outside of the country where the product was purchased will continue to be covered by the Limited Warranty.

Please work with your dealer to resolve any warranty issues. Should your dealer require any additional assistance, they will contact the appropriate person at POLARIS.

This warranty gives you specific legal rights, and you may also have other rights which vary from state to state or in different countries. If any of the above terms are void because of federal, state, local law, all other warranty terms will remain in effect.

For questions call POLARIS Customer Assistance:

United States & Canada: 1-800-POLARIS (1-800-765-2747)

French: 1-800-268-6334

WARRANTY

U.S.A. EPA Emissions Limited Warranty

This Emissions Limited Warranty is in addition to the POLARIS standard Limited Warranty for your vehicle. POLARIS Industries Inc. warrants that at the time it is first purchased, this emissions-certified vehicle is designed, built and equipped so it conforms with applicable U.S. Environmental Protection Agency emission regulations. POLARIS warrants that the vehicle is free from defects in materials and workmanship that would cause it to fail to meet these regulations.

The warranty period for this emissions-certified vehicle starts on the date the vehicle is first purchased and continues for a period of 200 hours of engine operation; 4,000 kilometers (2,485 miles) of vehicle travel; or 30 calendar months from the date of purchase, whichever comes first.

This Emissions Limited Warranty covers components if their failure increases the vehicle's regulated emissions, and it covers components of systems if their only purpose is to control emissions. Repairing or replacing other components not covered by this warranty is the responsibility of the vehicle owner. This Emissions Limited Warranty does not cover components if their failure does not increase the vehicle's regulated emissions.

For exhaust emissions, emission-related components include any engine parts related to the following systems:

- Air-induction system
- Fuel system
- Ignition system
- Exhaust gas recirculation systems

The following parts are also considered emission-related components for exhaust emissions:

- Aftertreatment devices
- Crankcase ventilation valves
- Sensors
- Electronic control units

The following parts are considered emission-related components for evaporative emissions:

- Fuel Tank
- Fuel Cap
- Fuel Line
- Fuel Line Fittings
- Clamps*
- Pressure Relief Valves*
- Control Valves*
- Control Solenoids*
- Electronic Controls*
- Vacuum Control Diaphragms*
- Control Cables*
- Control Linkages*
- Purge Valves
- Vapor Hoses
- Liquid/Vapor Separator
- Carbon Canister
- Canister Mounting Brackets
- Carburetor Purge Port Connector

*As related to the evaporative emission control system.

WARRANTY

U.S.A. EPA Emissions Limited Warranty

The exclusive remedy for breach of this Limited Warranty shall be, at the exclusive option of POLARIS, repair or replacement of any defective materials, components or products. THE REMEDIES SET FORTH IN THIS LIMITED WARRANTY ARE THE ONLY REMEDIES AVAILABLE TO ANY PERSON FOR BREACH OF THIS WARRANTY. POLARIS SHALL HAVE NO LIABILITY TO ANY PERSON FOR INCIDENTAL, CONSEQUENTIAL OR SPECIAL DAMAGES OF ANY DESCRIPTION, WHETHER ARISING OUT OF EXPRESS OR IMPLIED WARRANTY OR ANY OTHER CONTRACT, NEGLIGENCE OR OTHER TORT OR OTHERWISE. THIS EXCLUSION OF CONSEQUENTIAL, INCIDENTAL, AND SPECIAL DAMAGES IS INDEPENDENT FROM AND SHALL SURVIVE ANY FINDING THAT THE EXCLUSIVE REMEDY FAILED OF ITS ESSENTIAL PURPOSE.

ALL IMPLIED WARRANTIES (INCLUDING BUT NOT LIMITED TO ANY IMPLIED WARRANTIES OF MERCHANTABILITY AND FITNESS FOR A PARTICULAR PURPOSE) ARE LIMITED IN DURATION TO THE WARRANTY PERIOD DESCRIBED HEREIN. POLARIS DISCLAIMS ALL EXPRESS WARRANTIES NOT STATED IN THIS WARRANTY. Some states do not allow limitations on how long an implied warranty lasts, so the above limitation may not apply if it is inconsistent with the controlling state law.

This Limited Warranty excludes failures not caused by a defect in material or workmanship. This Limited Warranty does not cover damage due to accidents, abuse or improper handling, maintenance or use. This Limited Warranty also does not cover any engine that has been structurally altered, or when the vehicle has been used in racing competition. This Limited Warranty also does not cover physical damage, corrosion or defects caused by fire, explosions or other similar causes beyond the control of POLARIS.

Owners are responsible for performing the scheduled maintenance identified in the owner's manual. POLARIS may deny warranty claims for failures that have been caused by the owner's or operator's improper maintenance or use, by accidents for which POLARIS has no responsibility, or by acts of God.

Any qualified repair shop or person may maintain, replace, or repair the emission control devices or systems on your vehicle. POLARIS recommends that you contact an authorized POLARIS dealer to perform any service that may be necessary for your vehicle. POLARIS also recommends that you use only POLARIS parts. It is a potential violation of the Clean Air Act if a part supplied by an aftermarket parts manufacturer reduces the effectiveness of the vehicle's emission controls. Tampering with emission controls is prohibited by federal law.

If you have any questions regarding your warranty rights and responsibilities, please contact POLARIS Customer Assistance:

United States & Canada: 1-800-POLARIS (1-800-765-2747)

French: 1-800-268-6334

MAINTENANCE LOG

Present this section of your manual to your dealer each time your snowmobile is serviced. This will provide you and future owners with an accurate log of maintenance and services performed on the snowmobile.

DATE	MILES (KM)	TECHNICIAN	SERVICE PERFORMED / COMMENTS
	150 mi. (240 km)		
	500 mi. (800 km)		
	1000 mi. (1600 km)		
	2000 mi. (3200 km)		

INDEX

0-9

12-Volt Receptacle 29

A

Adjustable Headlights 28
Avalanches 16

B

Battery **129-133**
 Charging 132-133
 Installation 131
 Removal 129-130
 Storage 131, 135
Belt Break-In 76
Brake Fluid Level 69
Brake Lever Travel Inspection 69
Brakes **69, 110-112**
 Brake Fluid 111
 Components 110
 Inspection 110
 Lever Travel 110
 System Bleeding 112
Break-In Period 75-76

C

Carbide Skags 65
Chaincase Oil 98-101
Cleaning for Matte Finishes 134
Cleaning/Preservation, Storage 135
Clutch Alignment Offset 114
Clutch Safety 19
Clutch System 114-118
Clutch/Drive System Care, Storage 136
Cold Weather Drive-Away 19
Control Arm Pivot Adjustment 126
Coolant 105
Coolant Level 105
Cooling System 105-107
Cooling System, Bleeding 106-107
Cooling System, Flushing 106
Customer Service 163

D

DET 32-33
Diagnostic Display Codes 92-93
Diagnostic Display Mode 49
Disabled Operators 13

D

Drive Belt
 Adjustment 116
 Break-In 76
 Condition 115
 Deflection 116
 Installation 118
 Removal 117
 Safety 19
Drive Chain Tension 109
Driver Awareness 15
Driveshaft Bearing Lubrication 98
Driving Downhill 18
Driving in Hilly Terrain 18
Driving on Slippery Surfaces 17
Driving Responsibly 20

E

Electrical Connections, Storage 136
Emission Control Information 87
Engine Break-In 75-76
Engine Overheating 34-35
Engine Protection, Storage 136
Engine Restarting 74
Engine Safety 11
Engine Serial Number 8
Engine Starting 74
Engine Stop Switch 81
Environment Preservation 6
Exhaust System 108

F

Fasteners, Side Panel 71
Fluid Change
 Chaincase 99-101
 Coolant 106
Fluid Level
 Brake Fluid 111
 Chaincase 98
 Coolant 105
Front (IFS) Shock Adjustments 54
Front Suspension (IFS)
 Factory Clicker Settings 53
 Factory Spring Settings 53
 Inspection 123
Fuel 78
Fuel Filter 101

INDEX

F

Fuel Lines	101
Fuel Premix (Initial Fill)	75
Fuel Pump	101
Fuel Recommendation	79
Fuel System Deicers	79
Fuel Type Selection	31
Fuel Warnings	78

G

Guide, Suspension Set-Up	51-59
--------------------------	-------

H

Handlebar Adjustments	60-61
Handlebar Angle	61
Handlebar Components	
Fastener Torques	62
Component Locations	63
Headlight Replacement	113
Hood	94
Hood Removal / Installation	95

I

Ice and Snow Build-up	17
Ignition Lock System	35, 43-48
Ignition Switch	73
Inadequate Snow Conditions	17
Indicator Lights	37
Information Display Area	40
Inspection, Pre-Ride	66
Instrument Cluster	36-45, 47-50
Intake Filters	102
Intake Silencer	19

K

Key Identification	8
--------------------	---

L

Lights/Replacement	113
--------------------	-----

M

Maintenance Interval Table	89-91
Maintenance Program	88
Maintenance Recommendations	10
Maneuverability	19
Matte Finish Cleaning	134
Metric/Standard Display	42

O

Odometer/Engine Hour Display	41
Oil Change, Chaincase	99-101
Oil Injection System	76
Oil Level, Chaincase	98
Oil Level, Injection	80
Oil Recommendations	75
Operating in Deep Snow	17
Operator Safety	9-21
Overheating, Engine	34-35

P

Parking Brake Lever Lock	70
Playback Function	41
Polaris Products / Part Numbers	137
Pre-Ride Checklist	66
Pre-Ride Suspension Inspection	67

R

Rail Slide Wear	128
Recoil Rope Inspection	71
Registration, Warranty	164
Reverse Operation	84-85
Rider Capacity	14
Rider Information Center	38-49
Riding Apparel	12
Riding Position	11
Riser Angle	60

S

Saddlebags	30
Safety Labels	22-25
Safety Symbols	9
Security System	35, 43-48
Set-Up Guide, Suspension	51-59
Shock Lubrication, Rear Shock	98
Side Panel Fasteners	71
Side Panels (Opening/Removing)	94
Signal Words	9
Skags, Carbide	65
Ski Alignment	124
Ski Skags	125
Ski Toe Settings	124
Slide Rail and Track Cooling	77
Snow Conditions	17
Spark Plug Condition	104
Spark Plug Inspection	104
Spark Plug Recommendations	103
Spark Plugs	103-104

INDEX

S

Specifications/Clutching

600 RUSH PRO-S	138
600 RUSH PRO-X (Int'l)	140
600 SWITCHBACK ADV	146
600 SWITCHBACK ADV (Int'l)	148
600 SWITCHBACK PRO-S	142
600 SWITCHBACK PRO-X (Int'l)	144
800 RUSH PRO-S	150
800 RUSH PRO-X	152
800 SWITCHBACK PRO-S	154
800 SWITCHBACK PRO-X	156
Speed	14
Speed Display	40
Standard/Metric Display	42
Starting the Engine	74
Starting the Engine, Restarting	74
Steering System	123-125
Steering System Inspection	71
Stopping, Emergency	73
Storage Compartment, Heated	29
Storage, Seasonal/Extended	134, 136
Storage, Daily	86
Studs	64
Survival Preparation	13
Suspension Control Arms, Front	126
Suspension Inspection, Pre-Ride	67
Suspension Inspection, Rear	127
Suspension Quick Set-Up Guide	51-59
Suspension, Rear	127-128
Switches	
Engine Stop Switch	81
Ignition Switch	73
Mode/Select Buttons	36, 50
Mode/Set Switch	36, 50

T

Taillight/Brakelight Replacement ..	113
Throttle Lever	68, 82-83
Throttle Lever Freeplay	82-83
Throttle Release Switch	81
Throttle Release Switch Inspection ..	68
Tools	96-97
Towing	86
Track	
Alignment	122
Inspection	119
Lubrication	119
Tension	120-121
Track Care, Storage	136
Track Inspection	71
Track Maintenance	119-122
Track Safety	11
Track Warm-Up	77
Traction Products	64-65
Transporting the Snowmobile	136
Troubleshooting, Drive Belt	162
Troubleshooting, Engine	158-160
Troubleshooting, Suspension	161
Tune-Up	134

V

Vehicle Identification Numbers	7
--------------------------------------	---

W

Wear Strips	65
Windchill	21



For your nearest Polaris dealer,
call 1-800-POLARIS (765-2747)
or visit www.polaris.com
Polaris Industries Inc.,
2100 Hwy. 55, Medina, MN 55340
Part No. 9925073 Rev 01 Printed in USA



POLARIS[®]

* 9925073

*